

Pro 400

OPERATION MANUAL



Pro 400 Lacer Pictured.



Table of Contents

OPERATING INSTRUCTIONS

Machine Preparation - Pro 400.....	1
Belt Preparation.....	3
Selecting and Installing the Proper Adapter/Comb.....	3
Selecting the Correct Size Gauge Pin.....	4
Determining the Number of Hooks Required.....	5
Inserting Hooks, Gauge Pin and Belt	5
Determine the Correct Pressure and Gauge Pin - Pro 400.....	7
Removing the Belt/Hook Assembly from Machine.....	8
Carding Paper Removal	9
Installing Hooks on Belt Ends Requiring More Than One Strip of Hooks.....	9

Appendix

Troubleshooting	10
Suggested Workbench Setup - Side View.....	11
Suggested Workbench Setup - Front View	12
Pro 400 Exploded Drawing.....	13
Pro 400 Parts List.....	14
Log Shee	15
Schematic Diagram	17
Spare Parts List.....	18

Machine Preparation - Pro 400

- Place the machine on a solid work surface. We recommend that you construct a work bench. Recommendations are made on Pages 11 and 12.
- Remove the plug from the hydraulic fluid reservoir (save plug for future transportation of lacer). Install the breather cap and ensure that the hydraulic fluid level is adequate. **IMPORTANT:** The machine can be damaged if the fluid is too low or the Breather Cap is not properly installed. The fluid level should be checked at least once a month and more often if the machine is heavily used. Add standard hydraulic fluid if necessary.



- Before connecting the machine to the power supply, be sure the switch is in the “off” position.
- Connect the machine to the proper power supply (120 volt, 60Hz.).

Operating Instructions for Belt Lacers equipped with a SIEMENS TD200 – Control Unit without heating mode

1. How to Change the Operational Mode:

You may change the operational mode by using the F1 – F7 functional keys. The preferred operational mode can be selected by pushing one of the functional keys. The lacing machine is supplied with the following pre-settings:

F1 **F5** **F6** **F7**

Pressing Mode

Pressure: 75 bar Holding Time: 1 sec

F2

Pressing Mode

Pressure: 300 bar Holding Time: 5 sec

F3

Pressing Mode

Pressure: 400 bar Holding Time : 5 sec

F4

Pressing Mode

Pressure: 500 bar Holding Time : 5 sec

F8



Switches **Pressure bar** to **psi**.



Note: We have used the pre-setting only for reference. You will have to change the settings according to your belt material, fasteners selected and belt width to be laced.

2. How to Change the Settings for Pressure and Holding Time:

The settings of the F1 – F7 keys can be changed as follows:

Select the mode to be changed (F1 – F7). Then press the  key till it arrives at the setting to be changed (pressure or holding time). To select the value to be changed please press the ENTER key until you get the value to be changed.

 to increase the numerical value
 to decrease the numerical value

To accelerate the process press and hold the  or  keys until the desired value is achieved. Finally press **ENTER** to accept your desired settings.

Note: If you try to set the values beyond factory-set limits of your belt lacer, then the last setting will be kept and the new value will be ignored.

Belt Preparation

1. Cut belt using the center-line cutting method to ensure a square cut. Follow the instructions below:
 - a. Prior to any work on your conveyors, make certain that the power has been turned off and the belt is "locked out".
 - b. Mark the actual center points in belt width at intervals of 3 to 5 feet, for a distance of 15 to 20 feet back from the intended splice area (Fig. 1).
 - c. Using either a steel rule or a chalk line, mark the average center line through the points measured in Step 2 (Fig. 2).
 - d. Using a square, draw a line perpendicular to the average center line across the belt width (Fig. 2).
 - e. Using the Clipper® 845LD Cutter, cut the belt on the line drawn in Step 4.
2. Skive impression cover off from the belt ends that will be laced, if applicable. Skive back 3/4" (Fig. 3).
3. Select the proper hook for the belt/application. If the belt has an impression cover it is important to select the hook based on the thickness of the skived portion.

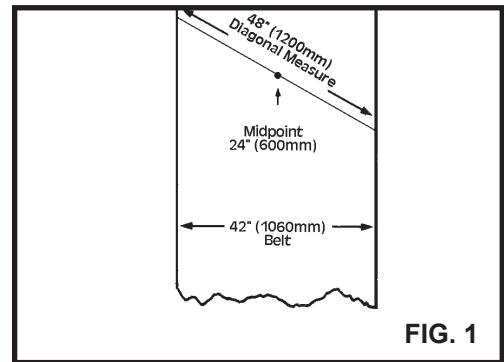

FIG. 1

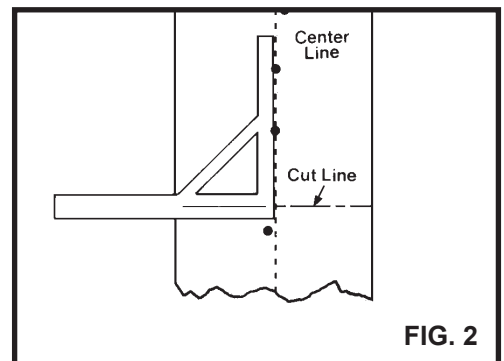

FIG. 2

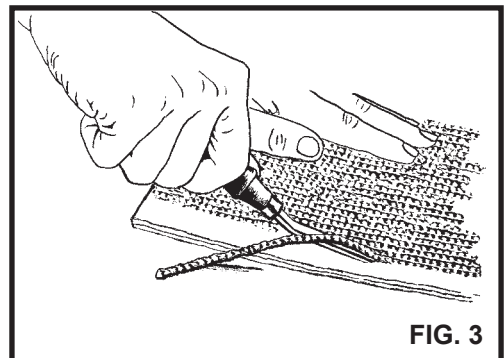

FIG. 3

Selecting and Installing the Proper Adapter/Comb

The adapter you will need is determined by the hook you have selected for your application. Below is a chart displaying hook sizes and their corresponding adapters, gauge pins and hinge pins.

HOOK SIZE	PRO 400 ADAPTER	GAUGE PINS (mm)
#25	P4CLPR25	1.5, 1.8x1.5, 2.0x1.5
#36/#30	P4CLPR36/30	1.5, 1.8x1.5, 2.0x1.5
#1	P4CLPR1	1.8, 2.0, 2.5x2.0, 3.0x2.0
#2 - #7	P4C2	2.5, 3.5x3.0, 4.0x3.0

Installing the Adapter

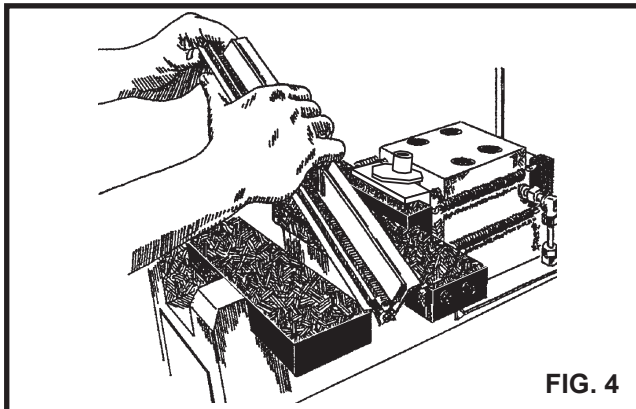

FIG. 4

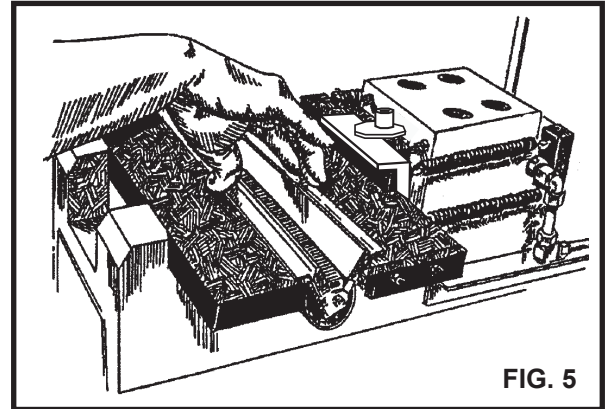

FIG. 5

Insert one end of the adapter into the jaws of the machine, and push down until it bottoms out (Fig. 4). If necessary, squeeze the adapter together slightly while performing this operation. If you prefer to apply lacing to the belt from left to right, position the extra deep slots/transfer section to the left of the machine. Lacing the belt from right to left requires placing the transfer section to the right of the machine.

Drop the remainder of the adapter into place, using caution to avoid pinching fingers (Fig. 5).

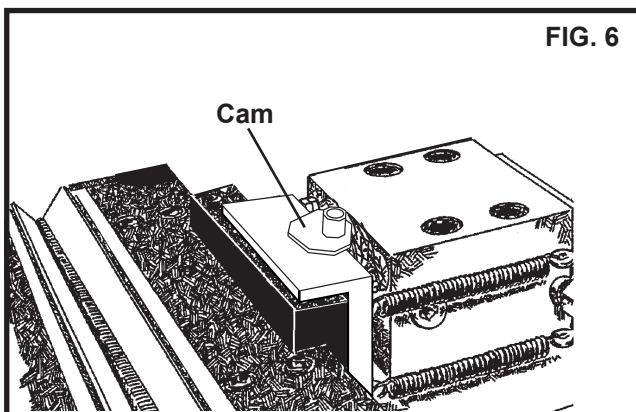

FIG. 6

Adjust the cam if the adapter will not fit into place, or if it is too loose (Fig. 6).

NOTE: The Cam limits how far the jaws retract. Adjusting the cam to a position where hooks can fit in retainer without fully retracting jaws can reduce cycle time.

Selecting the Correct Size Gauge Pin

The Pro 400 Lacer offer multiple size gauge pins to achieve an optimal loop profile. Select a gauge pin that is 20% to 30% thinner than your belt thickness.

Determine the Number of Hooks Required

Lay strips of hooks end-to-end across the entire width of your belt, leaving 1/4" of belt open on each side for notching. When it is necessary to cut a strip of hooks, cut only one strip.

The trailing end of the belt should have one less hook than the leading end. This is to prevent hooks from getting caught on the conveyor framework and pulling out. The trailing end should also be notched/tapered so as to prevent belt rips or tearing.

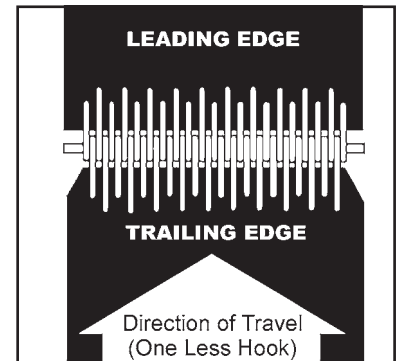

Inserting Hooks, Gauge Pin and Belt

Practice on a sample piece of belt, making sure the piece is from the same belt you intend to splice. This sample piece should ideally be 12" wide. If your belt is less than 12" wide use the narrower measurement. Install sample splice(s) to determine the proper pressure required to set the hooks. Record your results on the piece of belt and also in the log at the end of this booklet. Refer to this log whenever you splice this belt to avoid repeated experimentation.

Remember, the purpose for offering multiple gauge pin diameters is to eliminate the keyhole shaped loop and to provide the best possible hook set for optimum performance. If a keyhole shaped loop is produced, change the gauge pin to the next smaller size and apply new hooks to your sample.

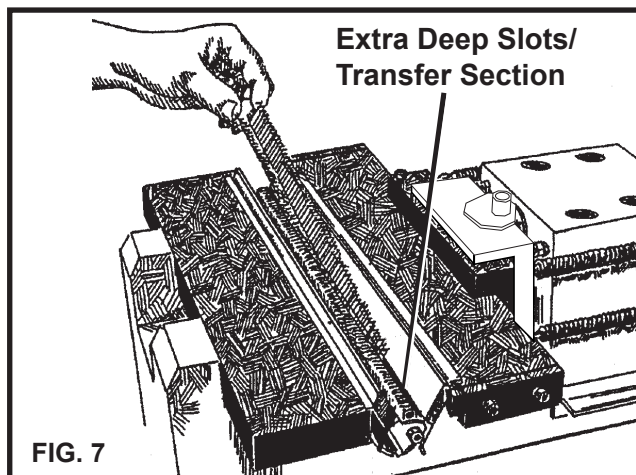

Center the shortest strip of hooks in the adapter first. Failure to center the strip may cause the machine to apply unequal pressure to the jaws, jamming the machine.

When installing full (12") strips of hooks, place one end hook into the slot adjacent to the transfer section (Fig. 7).

NOTE: Do not place unset hooks in the transfer section at any time.

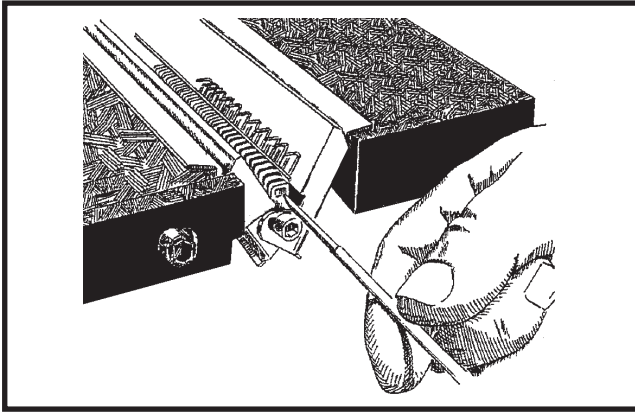

Insert the gauge pin flat side up (if applicable) into the hole in the comb opposite the transfer section and push it in completely. If using carded hooks as shown in Fig. 8, remove carding paper at this time. If installing Unibar® fasteners as shown in Fig. 9, remove safety strip now. If using carded hooks as shown in Fig. 10, the paper is removed after hooks are installed.

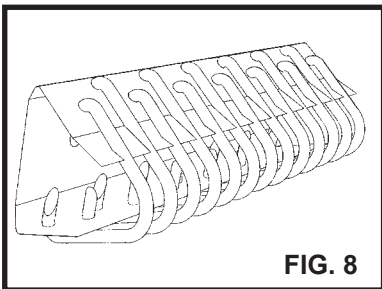

FIG. 8

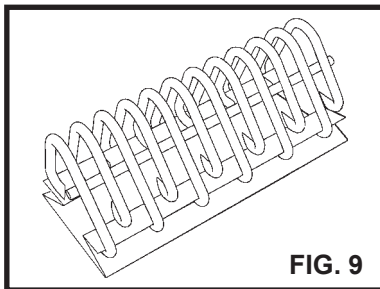

FIG. 9

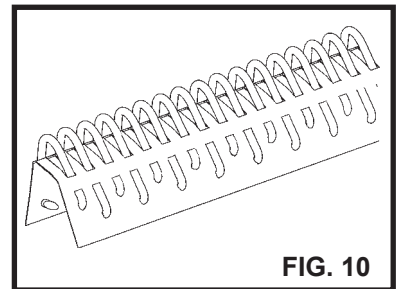

FIG. 10

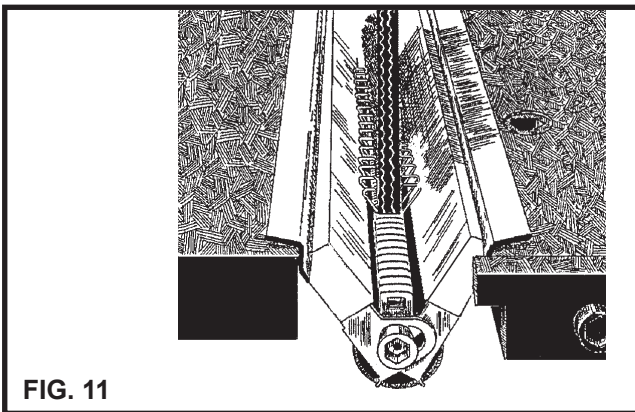

FIG. 11

Insert the belt between the points of the hooks and push it down flush against the comb (Fig. 11).

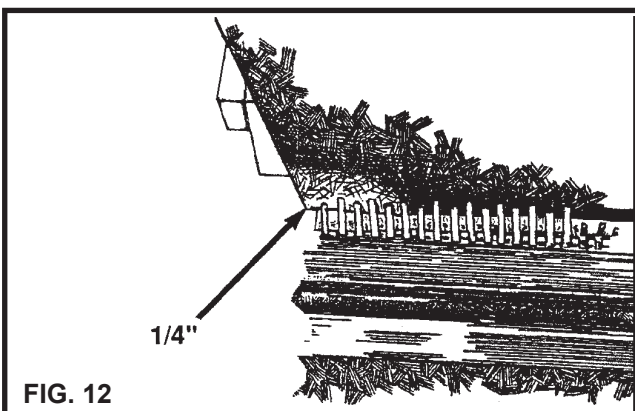
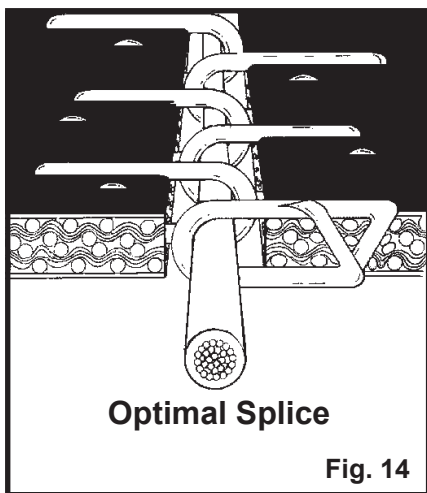

FIG. 12

When installing hooks in belts 12" wide or less be sure to center the hooks on the belt leaving 1/4" protruding from each end of the strip of hooks. This allows for notching the trailing end of the belt (Fig. 12).

When installing hooks into a belt wider than 12" (requiring two or more strips of hooks), leave 1/4" of belt protruding past the last hook near the transfer section.



Correct set is achieved when one-half to one-third the wire diameter of the hook is imbedded into the belt surface without a keyhole shaped loop and the points are just visible from the opposite side of the belt (Fig. 14).

Repeat the above procedures, increasing the pressure slightly until proper set is achieved.

If the loop has a keyhole shape, reapply new hooks using the next smaller gauge pin.

The hook points should be slightly visible on the opposite side of the belt. If the points are protruding through and curling over excessively, the hook is too large. Resplice using a smaller hook size.

Once you have determined the correct requirements for your belt, further experimentation becomes unnecessary. Enter this data in your log book and use it as a reference when splicing this belt in the future.

Determine the correct pressure and gauge pin required for your application

Turn the power switch to the "on" position (Fig. 15).



As a starting point set the pressure control to 100 bars when using 12" strips of hooks. Set it to 50 bars when applying 6" strips of hooks (Fig. 16).

Depress the foot switch and hold until all movement stops (Fig. 17). Release the foot switch momentarily and depress again until all motion stops. This allows the belt to adjust and the hooks to set properly. Release the foot switch and inspect the results.

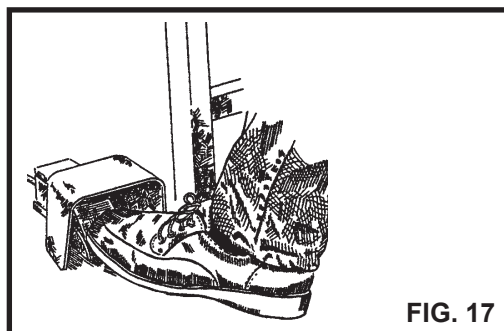

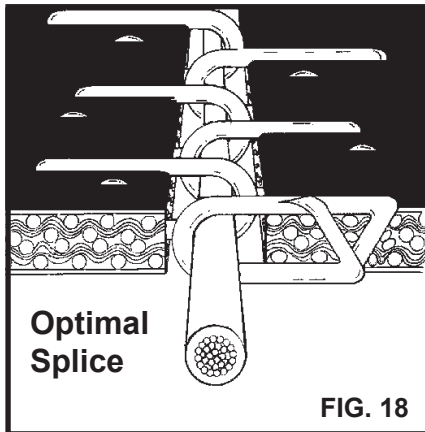

Correct pressure is achieved when one-half to one-third the wire diameter of the hook is imbedded into the belt surface without a keyhole shaped loop and the points are just visible from the opposite side of the belt (Fig. 18).

Increase the pressure setting in increments of 50 bars by following the instructions on page 1 and 2. Repeat this until proper setting of hooks is achieved.

If the loop has a keyhole shape, reapply new hooks using the next smaller gauge pin.

The hook points should be visible on the opposite side of the belt. However, if the points are protruding through and curling over excessively, the hook is too large. Reapply new hooks using a smaller hook.

Once you have determined the correct requirements for your belt, further experimentation becomes unnecessary. Enter this data in your log book and use it as a reference when splicing this belt in the future.

Removing Belt/Hook Assembly from Machine Pro 400

Pull the gauge pin completely out of the comb by pulling it straight out **without bending or twisting it. Twisting the gauge pin can break the handle off the gauge pin.** If necessary, push the belt back and forth to loosen the gauge pin.

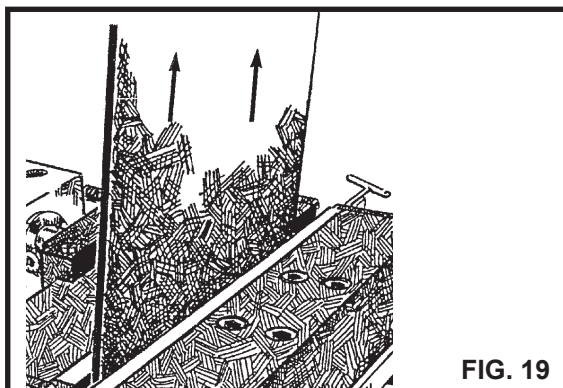

Pull the belt straight up and out of the machine. **Do not twist the belt as it is removed** (Fig. 19).

Do not change the pressure setting if you will be making additional splices on the same belt. The pressure setting, as well as the gauge pin will be used on future applications to this belt. However, splicing a different width piece of the same belt may require changing the pressure.

Example: You find that one 12" strip of hooks requires 300 bars of pressure to properly set in a particular belt. Applying one 6" strip of hooks of the same size in the same belt requires that the pressure be reduced 50%, to 150 bars.

Carding Paper Removal

If you installed carded hooks as shown in Fig. 20, remove the paper at this time by simply peeling it away after setting the hooks and removing the splice from the machine. The paper will separate from the hooks in one continuous piece (Fig. 21).

NOTE: To ease paper removal on #30 hooks, partially set the hooks, slit the paper lengthwise on one side of the belt and pull the paper away from each side of the belt (Fig. 22). Remove the paper before making the final set at full pressure.

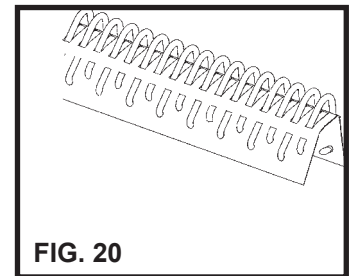

FIG. 20

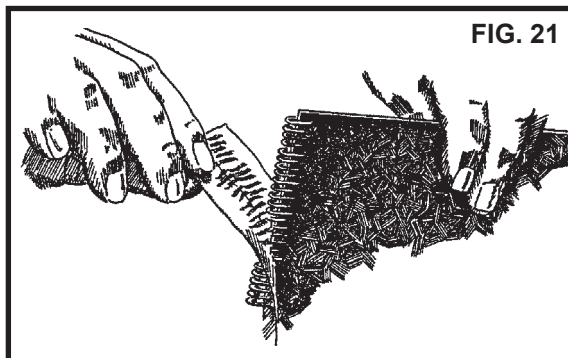

FIG. 21

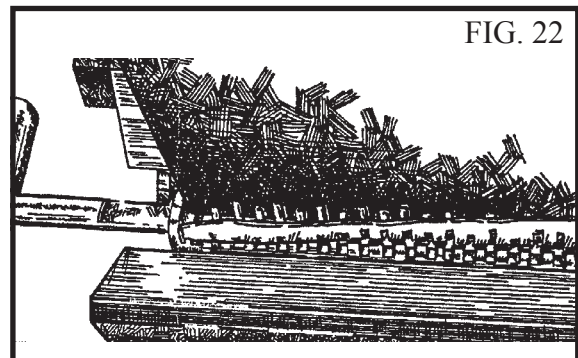

FIG. 22

Continuous Lacing Procedures:

After removing the belt with the first strip of hooks applied, insert the second strip of hooks into the comb. Make sure that an end hook is in the first slot adjacent to the transfer section and all the unset hooks are in the standard section of the comb (Fig. 23).

Insert the appropriate gauge pin, starting from the end of the comb opposite the transfer section, making sure the pin does not enter the transfer section. Remove carding paper from hooks, if applicable.

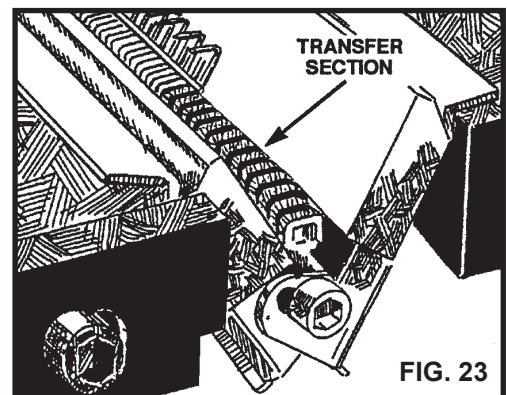

FIG. 23

Insert the previously installed hooks into the transfer section. Fill the transfer section with applied hooks only.

At this point every slot in the comb should have a hook in it. Push the gauge pin completely into the comb. Continue with installation as with a single strip of hooks.

Repeat the application procedure on the second belt end. There is no need to repeat the "experimenting" section when splicing several pieces of the same belt.

Maintain a log containing the belt name, hook size, gauge pin used, hinge pin and the pressure setting for future use. Use this log and you will avoid "experimenting" every time you splice a belt. Log pages are included at the end of this booklet.

TROUBLESHOOTING

1. Machine will not operate.

PRO 400

- A. Is the machine plugged in and the power switch on?
- B. Check power supply. Is there electricity at the outlet?
- C. Press reset button located inside the electrical box.
- D. Change the fuse located inside the electrical box. A spare fuse is located in the box.

2. Electric pump operates but jaws do not move.

- A. Is the pressure gauge set above 60 bars?
- B. Have you checked the hydraulic fluid level (and installed the breather cap on the Pro 400)?
- C. Are the jaws cocked at an angle?

3. Jaws close unevenly into the lacer.

Insert the retainer. Close the jaws 3-4 times without hooks or a belt inserted between the jaws. This should straighten the jaws out.

Suggested Workbench Setup:

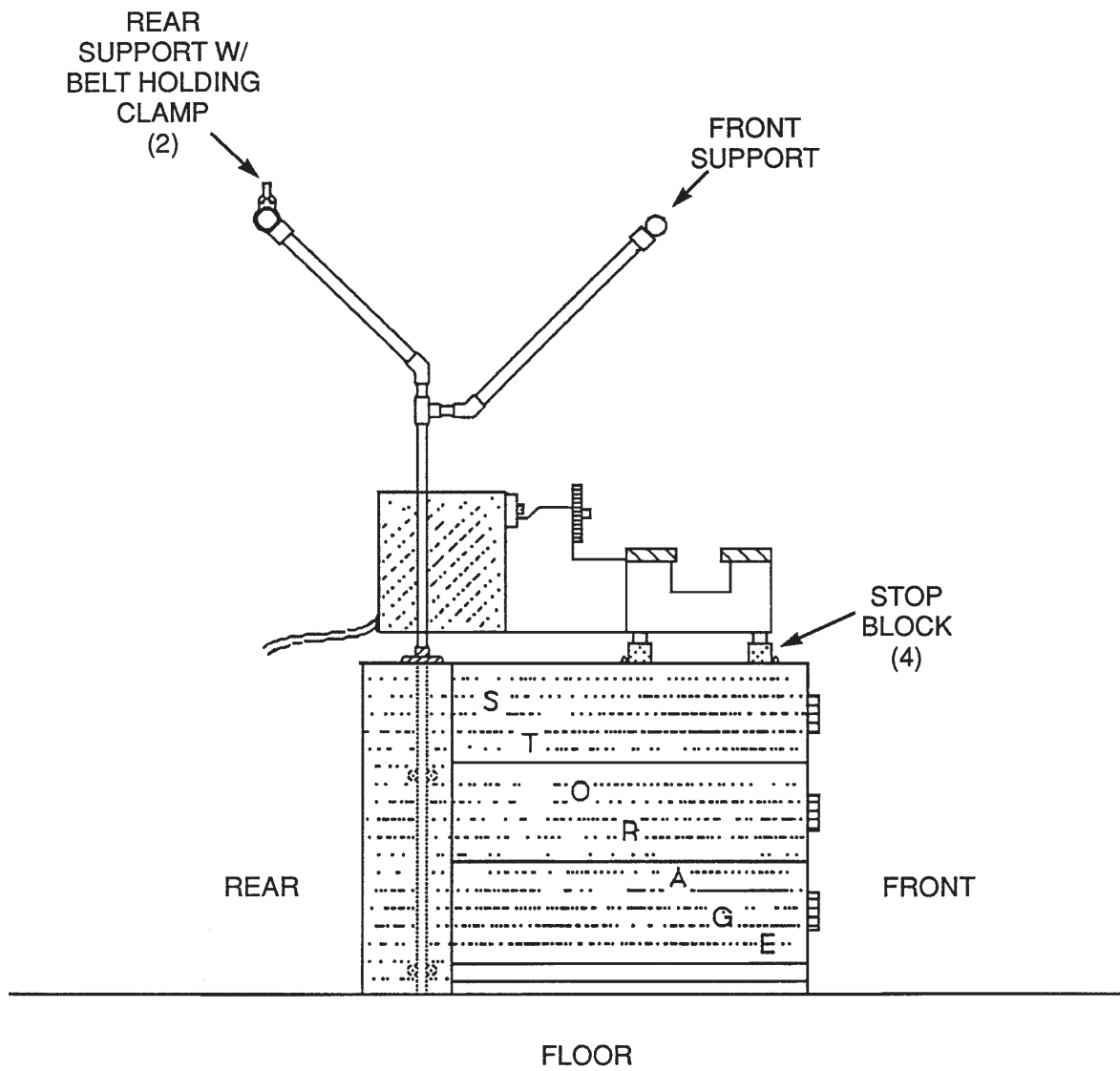

SIDE VIEW

Suggested Workbench Setup:

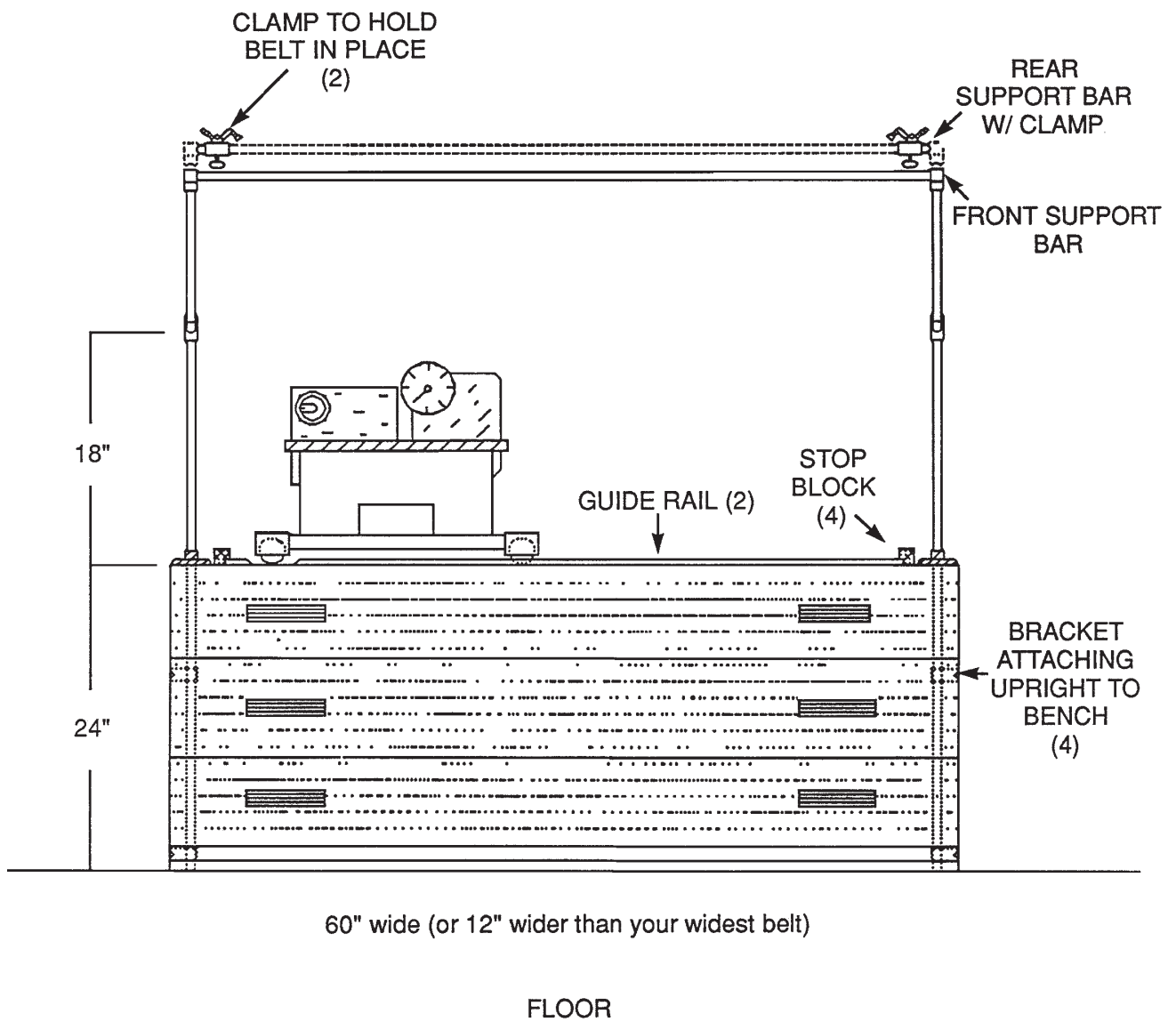

PRO 400 EXPLODED DRAWING

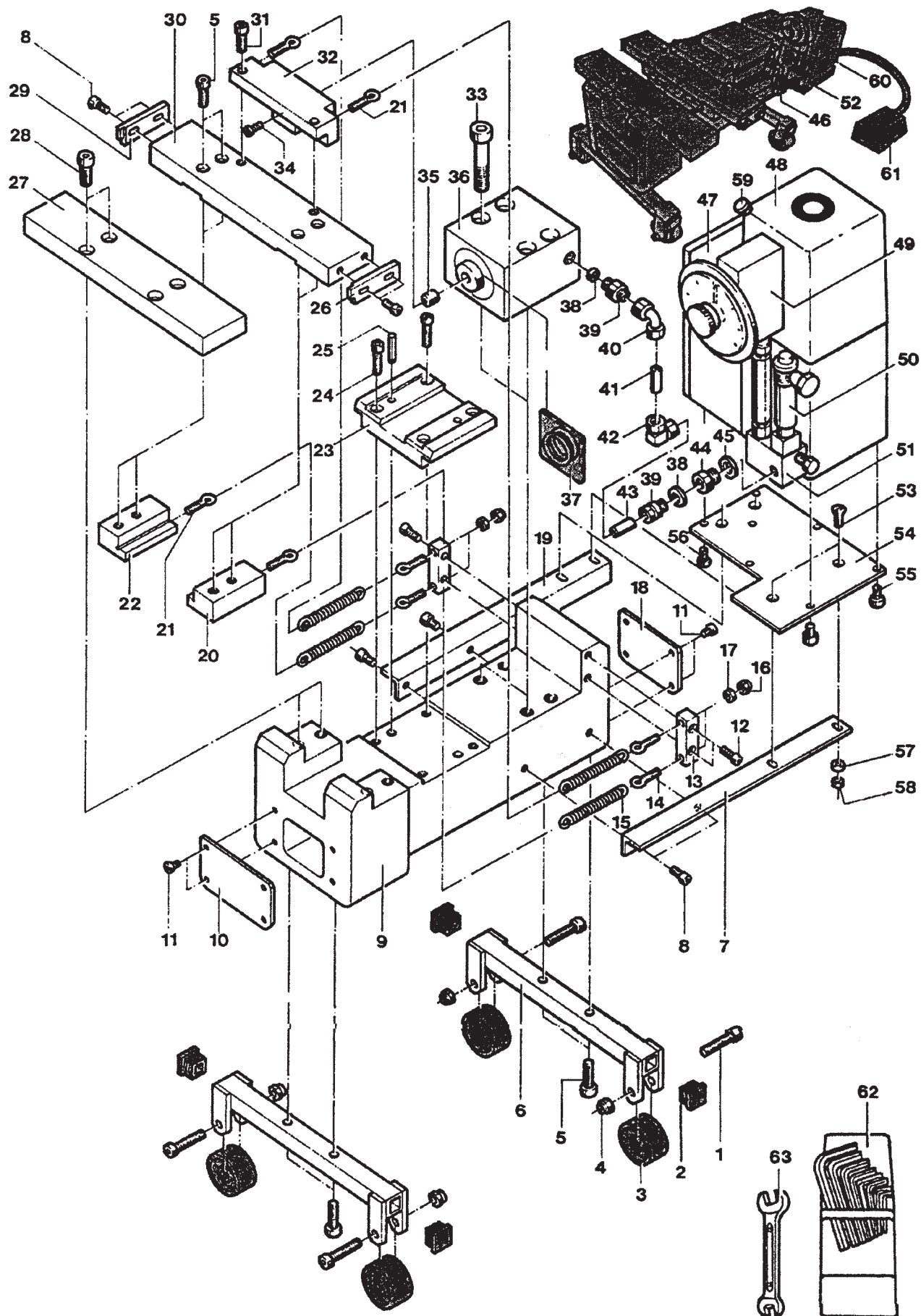

PRO 400 PARTS LIST

ITEM	QTY	ITEM CODE	DESCRIPTION
01	4		HSHC SCREW
02	4		PVC PLUG
03	4		WHEEL
04	4		SELF-LOCKING HEX NUT
05	12		HSHC SCREW
06	2		WHEEL BRACKET
07	1		PUMP HOLDER, RIGHT
08	8		HSHC SCREW
09	1		CAST BODY P400 COMPLETE, PAINTED
10	1		COVER SHEET, FRONT
11	8		SLOTTED CHEESE HEAD SCREW
12	4		HSHC SCREW
13	2		SPRING HOLDER
14	4		LIFTING EYE BOLTS
15	4		SPRING
16	4		SELF-LOCKING HEX NUT
17	4		HEX NUT
18	1		COVER SHEET, REAR
19	1		PUMP HOLDER, LEFT
20	1		SLIDING JAW TRACK, RIGHT
21	4		LIFTING EYE BOLTS
22	1		SLIDING JAW GUIDE TRACK, LEFT
23	1		SLIDING JAW GUIDE PLATE
24	4		HSHC SCREW
25	2		PARALLEL PIN
26	1		RETAINER HOLDING PLATE, RIGHT
27	1		FIXED JAW
28	4		HSHC SCREW
29	1		RETAINER HOLDING PLATE, LEFT
30	1		SLIDING JAW
31	2		HSHC SCREW
32	1		PRESS BLOCK
33	4		HSHC SCREW
34	1		HSHC SCREW
35	1		BUSHING
36	1		CYLINDER
37	1		SEAL SET FOR CYLINDER
38	2		SEAL RING
39	2		HYDRAULIC FITTING
40	1		HYDRAULIC FITTING

PRO 400 PARTS LIST (Continued)

41	1		HYDRAULIC TUBE
42	1		HYDRAULIC FITTING
43	1		HYDRAULIC TUBE
44	1		REDUCTION PIECE
45	1		SEAL RING
46	1		HYDRAULIC FITTINGS
47	1		ELECTRIC SWITCH BOX
47A	1		SWITCH BLOCK
47B	1		BI-RELAY MOTOR
47C	1		CONTRACTOR
47D	1		CAPACITOR
47E	1		FUSE 2A
47F	1		CASING
47G	1		SMALL-PART SET
48	1		HYDRAULIC PUMP UNIT
49	1		HYDRAULIC PRESSURE SWITCH
50	1		MAGNETIC VALVE
50A	1		MAGNETIC VALVE EXCHANGE
51	1		CONNECTING BLOCK TYPE B
52	1		COMPLETE CONNECTING BLOCK
53	4		SLOTTED COUNTERSUNK HS
54	1		PUMP BASE PLATE
55	4		HSHC SCREW
56	3		SELF-TAPPING SCREW
57	4		WASHER
58	4		HEX NUT
59	1		AIR FILTER
60	1		HYDRAULIC UNIT
61	1		FOOT PEDAL
62	1		HSHC SCREW DRIVER SET
63	2		WRENCH

LOG

CONV. NO.	BELT STYLE/ IDENTIFICATION	BELT THICKNESS	HOOK SIZE	GAUGE PIN USED	PRESSURE SETTING	HINGE PIN USED	COMMENTS

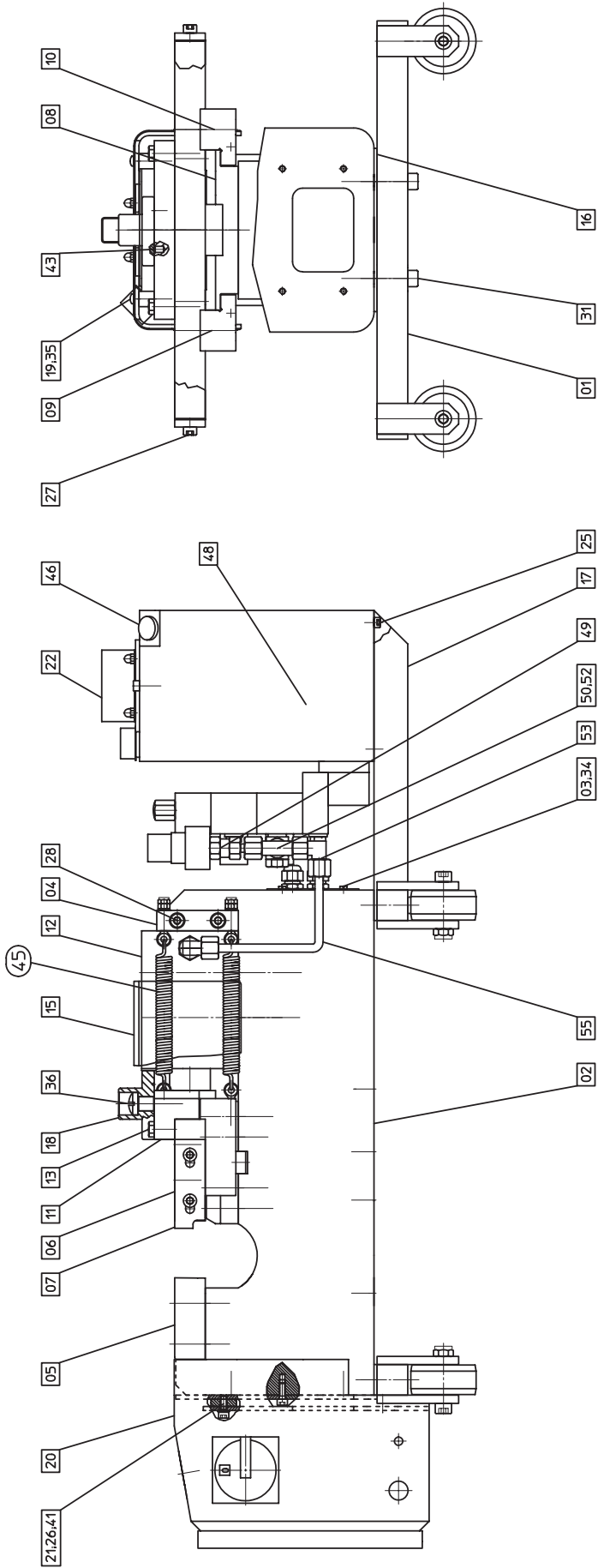

guide plate assembly 1:1

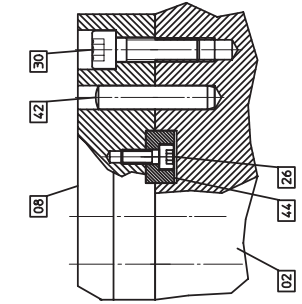

press block assembly 1:1

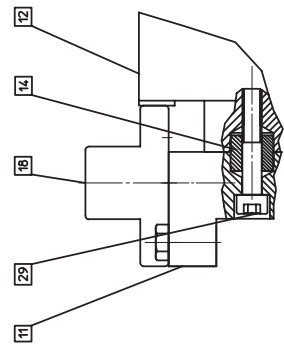

PRO 400

SPARE PART LIST PRO400

POS	QTY	DESCRIPTION	Draw.-No.
01	2	WHEEL BRACKET	AMK-4H-001
02	1	CAST BODY	AMU-4T-005
03	1	COVER SHEET REAR	AMU-4T-006
04	2	SPRING HOLDER	AMU-4T-007
05	1	FIXED JAW	AMK-4H-004
06	1	SLIDING JAW	AMK-4H-005
07		SIDE LAY	AMK-4H-006
08	1	SLIDING JAW GUIDE PLATE	AMU-4T-010
09	1	SLIDING JAW GUIDE TRACK LEFT	AMU-4T-011
10	1	SLIDING JAW GUIDE TRACK RIGHT	AMU-4T-012
11	1	PRESS BLOCK	AMU-4T-013
12	1	CYLINDER 200 KN	AMU-4T-016
13	2	WASHER HEAD BOLT	AMU-4T-025
14	1	BUSHING	AMU-4T-026
15	1	CYLINDER COVER	AMU-4T-027
16	1	SPACER	AMU-4T-028
17	1	PUMP BASE PLATE	AMU-4T-029
18	1	SPACER WASHER	ARU-2T-024
19	2	SPACER	ARU-2T-032

SPARE PART LIST PRO400

POS	QTY	DESCRIPTION	Draw.-No.
20	1	ELECTRIC SWITCH BOX	ARU-2T-047
21	2	SPACER	ARU-2T-048
22	1	COVER SHEET	HP1000-003
25	4	HSHC SCREW DIN 912 M6X12	
26	6	HSHC SCREW DIN 912 M6X16	
27	4	HSHC SCREW DIN 912 M6X16	
28	4	HSHC SCREW DIN 912 M8X30	
29	4	HSHC SCREW DIN 912 M8X50	
30	4	HSHC SCREW DIN 912 M10x35	
31	8	HSHC SCREW DIN 912 M10x45	
32	4	HSHC SCREW DIN 912 M12X35	
33	4	HSHC SCREW DIN 912 M16X120	
34	4	SLOTTED CHEES HEAD SCREW DIN 84 M4x6	
35	2	BUTTON HEAD SOCKET SCREWS ISO 7380 M5x25	
36	1	BUTTON HEAD SCREWS NLM754-12	
37	4	EYE BOLTS DIN 444 M6X30	
38	4	EYE BOLTS DIN 444 M6X40	
39	4	HEXAGON NUT DIN 934 M6	
40	4	SELF LOCKING HEXAGON NUT DIN 985 M6	

SPARE PART LIST PRO400

POS	QTY	DESCRIPTION	Draw.-No.
41	6	WASHERS DIN 125-B-6.4 ZINC PLATED	
42	2	PARALLEL PIN DIN 6325 10M6X50	
43	2	SPRING PLUNGER	
44	2	NOTCH-STONE NLM 03250-22	
45	4	SPRINGS	
46	1	HYDRAULIC UNIT	
47	1	FOOTPEDAL STEUTE GFSM 1Ö/1S	
49	1	HYDRAULIC FITTING MAVE08SR1/4A3C	
50	1	HYDRAULIC FITTING WH08SRA3C	
51	1	HYDRAULIC FITTING GE08SRA3C	
52	1	HYDRAULIC FITTING ET08SRA3C	
53	2	HYDRAULIC FITTING EW08SA3C	
54	1	REDUCTION PIECE RI1/2EDX1/4A3C	
55	1	HYDRAULIC TUBE 8X1.5MM	

2 Woodlands Sector 1 • #01-21 • Woodlands Spectrum I • Singapore 738068
Tel: +65-6484-1533 • Fax: +65-6484-1531 • E-mail: asiasales@flexco.com

Visit www.flexco.com for other Flexco locations and products.

©2017 Flexible Steel Lacing Company. 10/23/17. For reorder: X4824

