

PUN M™ Manual Finger Punch

300 - 600 - 900

Safety and Operation Manual

For punching thermoplastic belting materials only.

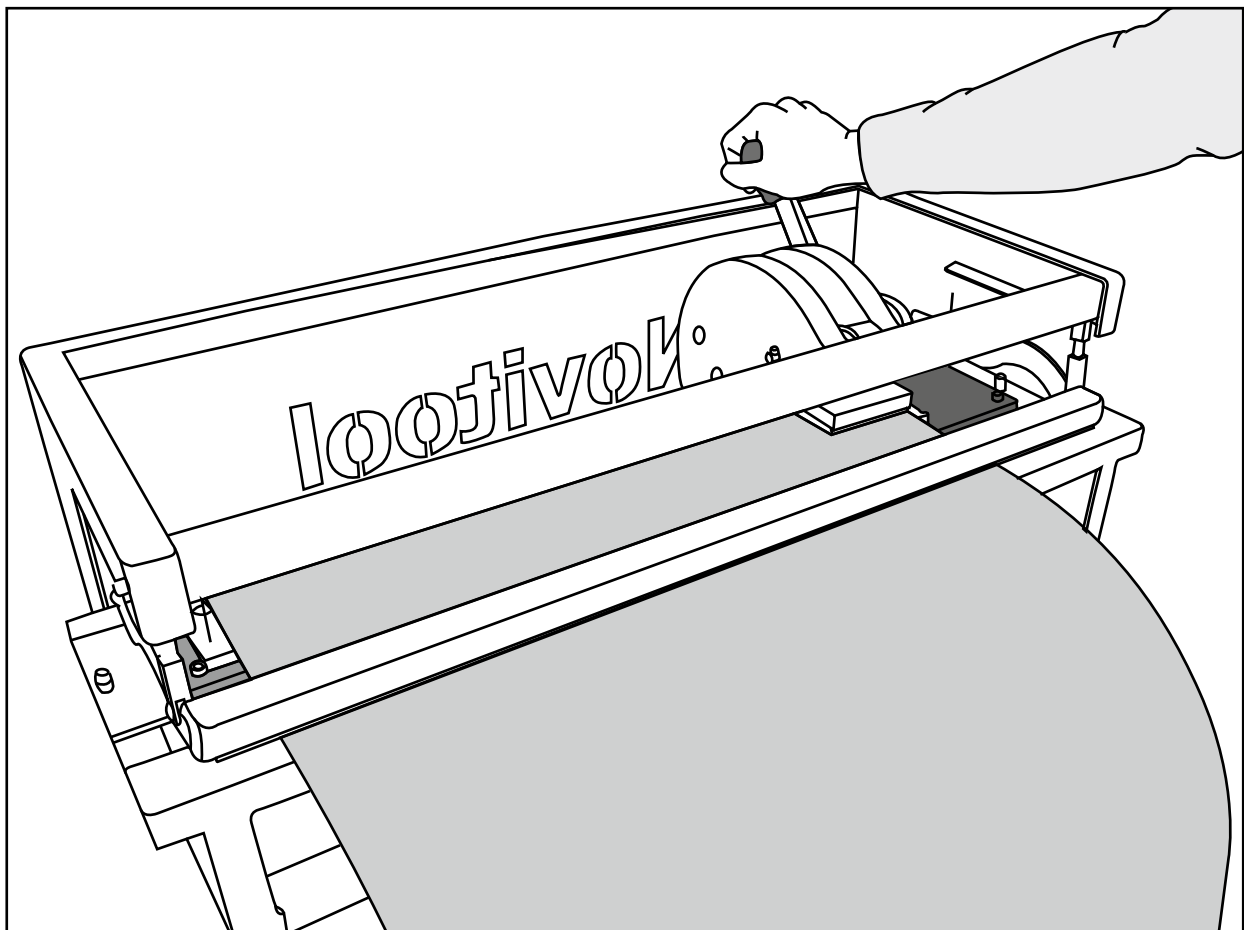

 **WARNING**

IMPROPER OR UNSAFE use of this tool can result in serious bodily injury! This manual contains important information about product function and safety. Please read and understand this manual BEFORE operating the tool. Please keep this manual available for other users and owners before they use the tool. This manual should be stored in a safe place.

Table of Contents

Main Components.....	3
Description.....	3
Tool Specifications.....	4
General Safety Rules.....	5
Work Preparation and Replacing Punchboards.....	7
Punching Single Fingers	12
Punching Finger over Finger	19
Bias Finger Punching.....	27
Bias Finger Over Finger Punching.....	32
Replacement Parts.....	41
Transportation Security.....	42

Main Components

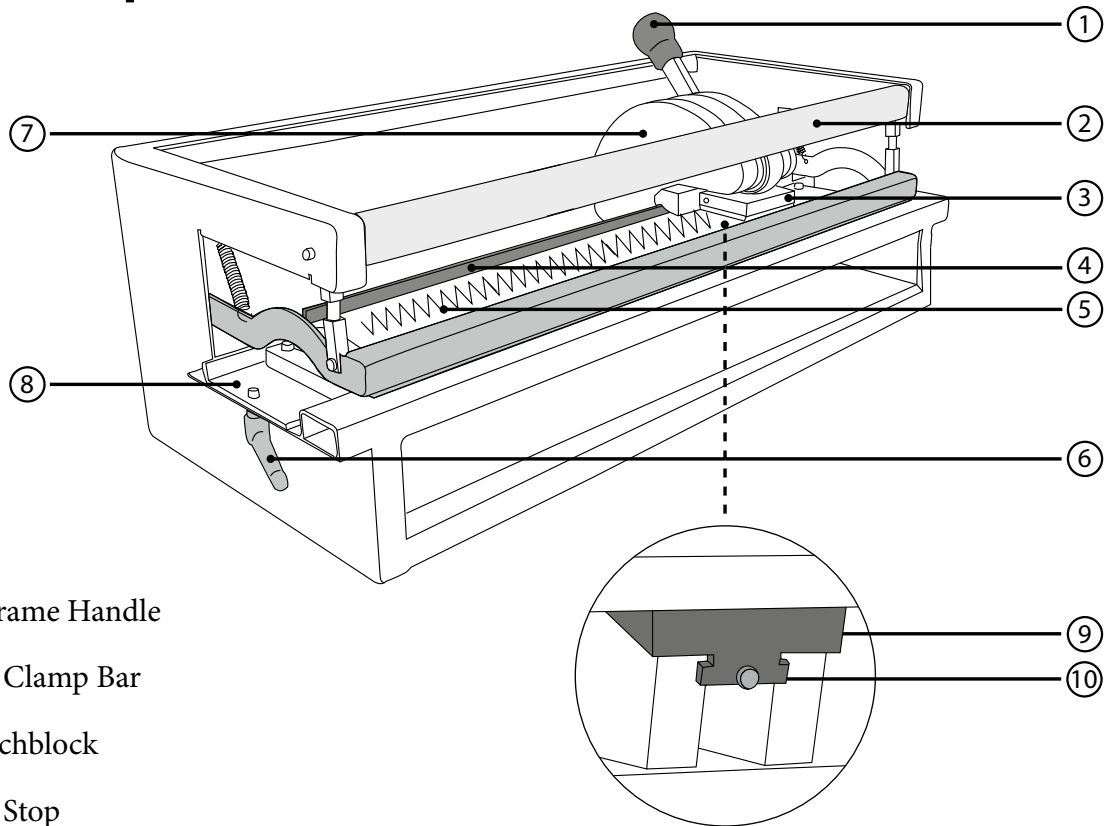

1. C-Frame Handle
2. Belt Clamp Bar
3. Punchblock
4. Belt Stop
5. Punchboard with Finger Knives
6. Lock Handle
7. C-frame
8. Punchboard Tray
9. C-frame Wedge
10. Fixation Screw and Punching Force Adjustment

Description

The PUN M™ is designed to punch fingers on the ends of lightweight thermoplastic conveyor belts as a preparation for making finger- or finger-over-finger splices.

The Pun M is manually operated and does not need electricity or air pressure for its operation. The punching force of 11,000 lbs. (50 kN) is created by pulling the lever and is easily done with one hand by an average person. Because of its easy set-up and manual operation, the Pun M is an ideal tool for working on location, as well as in a workshop.

Although all punchboards of the Pun M have a specified net width, the open construction of the frame allows belts of larger widths to be punched with these machines.

With one lever pull, a finger punch of 90 mm wide can be made (based on 50 × 20 fingers for finger-overlap-finger splicing) or 60 mm wide (based on 80 × 20 or 70 × 15 fingers for single finger splicing). The maximum thickness is up to 5 mm for light weight belting.

Tool Specifications

Pun M™ Dimensions				
	L	H	W	Weight
Pun M 300	23" 570 mm	15" 370 mm	14" 360 mm	31 lbs 14 kg
Pun M 600	34" 870 mm	15" 370 mm	14" 360 mm	37 lbs 17 kg
Pun M 900	46" 1170 mm	15" 370 mm	14" 360 mm	44 lbs 20 kg

Pun M™ Ordering Information		
Ordering Number	Effective Punching Length	Item Code
PUN-M-300	300	08016
PUN-M-600	600	08017
PUN-M-900	900	08018

Pun M™ Punchboard Specifications		
	Ordering Number	Item Code
Pun M 300 Punchboards		
1.97" × 0.79" (50 × 20 mm)*	PUN-B-50x20-300	08019
2.76" × 0.59" (70 × 15 mm)	PUN-B-70x15-300	08022
3.15" × 0.79" (80 × 20 mm)	PUN-B-80x20-300	08025
1.97" × 0.71" (50 × 18 mm)	PUN-B-50x18x31BIAS-300	08539
Pun M 600 Punchboards		
1.97" × 0.79" (50 × 20 mm)*	PUN-B-50x20-600	08020
2.76" × 0.59" (70 × 15 mm)	PUN-B-70x15-600	08023
3.15" × 0.79" (80 × 20 mm)	PUN-B-80x20-600	08026
1.97" × 0.71" (50 × 18 mm)	PUN-B-50x18x31BIAS-600	08540
3.15" × 0.79" (80 × 20 mm)	PUN-B-80x20x113BIAS-600	08439
Pun M 900 Punchboards		
1.97" × 0.79" (50 × 20 mm)*	PUN-B-50x20-900	08021
2.76" × 0.59" (70 × 15 mm)	PUN-B-70x15-900	08024
3.15" × 0.79" (80 × 20 mm)	PUN-B-80x20-900	08027
1.97" × 0.71" (50 × 18 mm)	PUN-B-50x18x31BIAS-900	08526
3.15" × 0.79" (80 × 20 mm)	PUN-B-80x20x113BIAS-900	08440

* Also suitable for Finger-Over-Finger splices.

** Custom Punch Boards Available Upon Request.

Pun M™ Punching Block Nylon Inlay	
Ordering Number	Item Code
PUN-M-NYLONPAD-KIT	08279

General Safety Rules—Save These Instructions—

Signal words:

“DANGER” indicates an imminently hazardous situation which, if not avoided, will result in death or serious injury. The signal word is limited to the most extreme situations.

“WARNING” indicates a potentially hazardous situation which, if not avoided, could result in death or serious injury.

“CAUTION” indicates a potentially hazardous situation which, if not avoided, may result in minor or moderate injury. It may also be used to alert against unsafe practices.

Safety Symbol



This international safety symbol is used to identify and call attention to specific safety matters.

Safety Information

To Avoid Severe Personal Injury or Property Damage, read carefully and understand the following Safety Precautions.

1. WORK AREA

⚠ CAUTION

Keep your work area clean and well lit. Cluttered benches and dark areas invite accidents.

2. PERSONAL SAFETY

⚠ WARNING

Stay alert, watch what you are doing and use common sense when operating a tool. Do not use tool while tired or under the influence of drugs, alcohol, or medication. A moment of inattention while operating tools may result in serious personal injury.

Dress properly. Do not wear loose clothing or jewelry. Contain long hair. Keep your hair, clothing, and gloves away from moving parts. Loose clothes, jewelry, or long hair can be caught in moving parts.

Do not overreach. Keep proper footing and balance at all times to enable better control of the tool in unexpected situations.

Never alter or remove safety devices.

Keep your hands and fingers away from the knives in the punchboard, at all times.

⚠ CAUTION

Use safety equipment. Always wear eye protection. Dust mask, non-skid safety shoes, hard hat, or hearing protection must be used for appropriate conditions.

General Safety Rules

3. TOOL USE AND CARE

WARNING

Always use the punching machine on a level, firm surface. Punching should be performed operating the machine with one hand on the handle and the other on the top part of the frame or C-frame.

Tool service must be performed only by qualified repair personnel. Service or maintenance performed by unqualified personnel could result in a risk of injury.

CAUTION

Maintain tools with care. Keep cutting tools sharp and clean. Properly maintained tools, with sharp cutting edges, are less likely to require unnecessary high forces and are easier to control. If damaged, have the tool serviced before using. Many accidents are caused by poorly maintained tools.

The Punching machine should not be used to punch materials other than thermoplastic belting materials. The thickness of the belting material should never exceed 0.32 inch (8 mm).

When servicing a tool, use only original Flexco replacement parts.

Do not wipe plastic parts with solvent. Solvents such as gasoline, thinner, benzene, carbon tetrachloride, and alcohol may damage and crack plastic parts. Do not wipe them with such solvents. Wipe plastic parts with a soft cloth lightly dampened with soapy water and dry thoroughly.

4. PUNCHBOARD SAFETY AND REPLACEMENT

CAUTION

Always use original Flexco punchboards in combination with the Pun M™.

Do not use dull or damaged punchboards.

Always protect yourself against the knives of unused punchboards by shielding them with cardboard packaging material or wood. This material should also protect the knives from getting damaged.

Work Preparation and Replacing Punchboards

A1

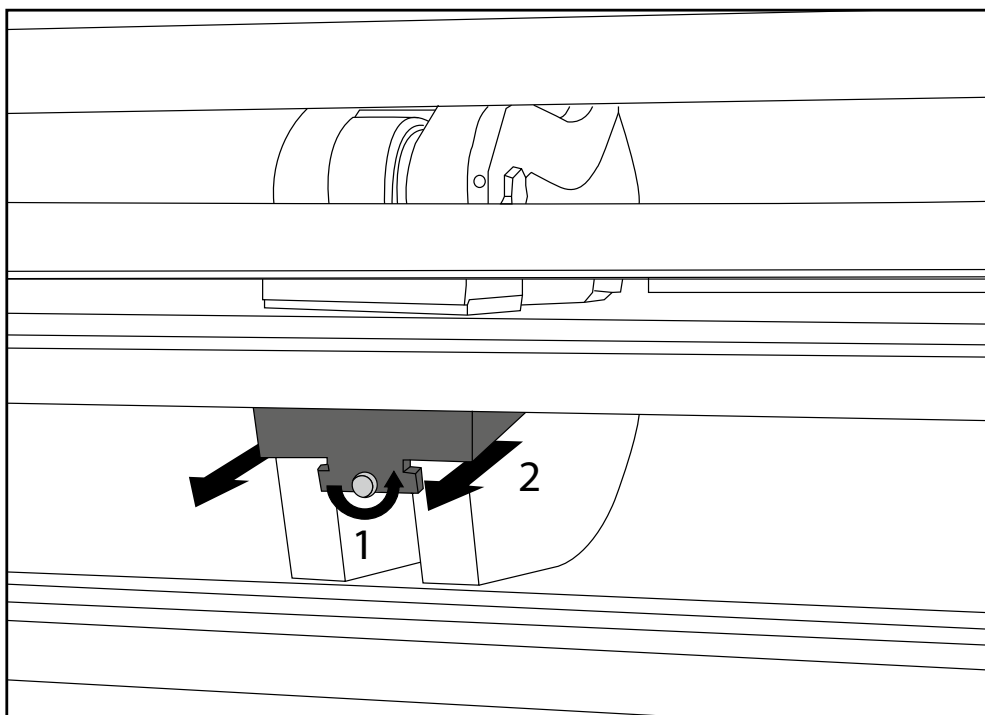

1. Loosen and remove fixation screw. 2. Take out the black C-frame wedge.

A2

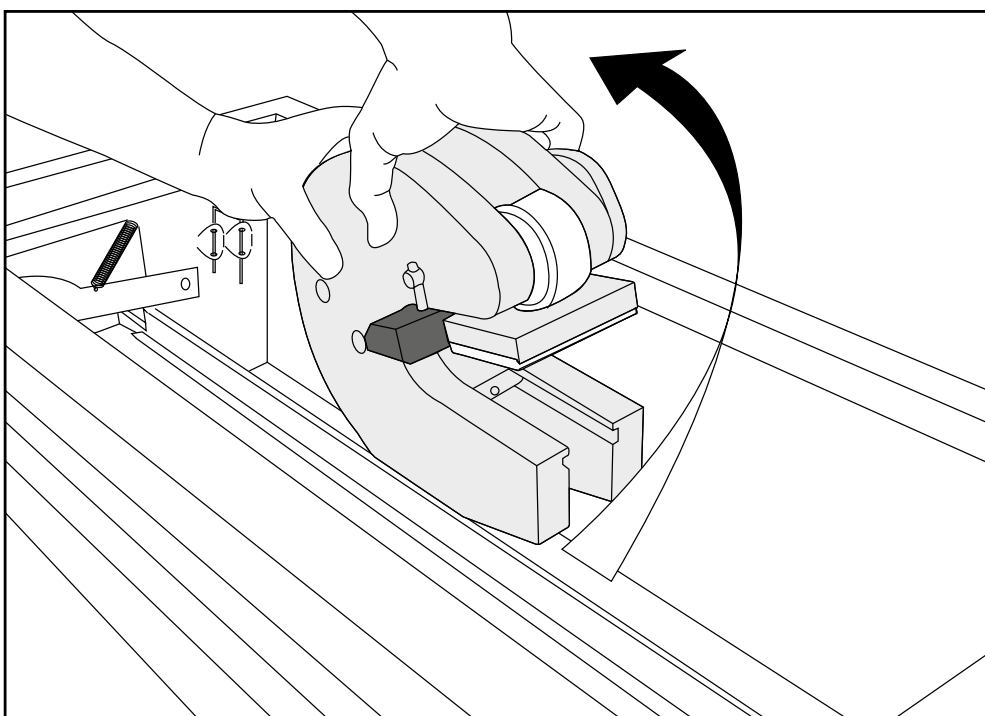

Ensure tray is in forward position. Twist C-frame to remove.

Work Preparation and Replacing Punchboards

A3

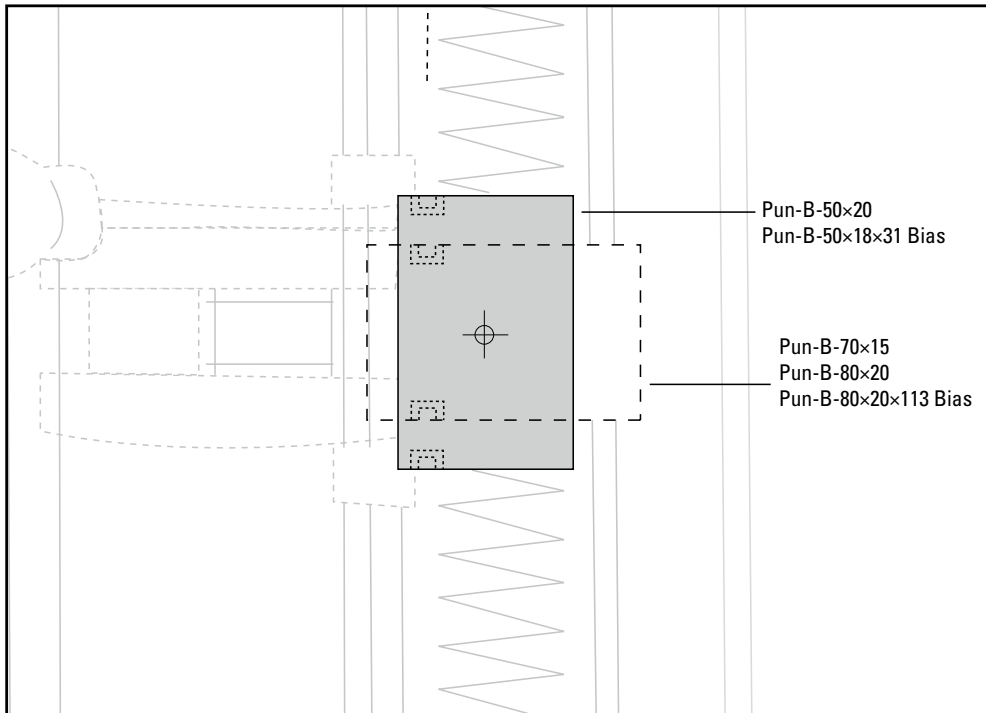

Determine required punchblock position.

A4

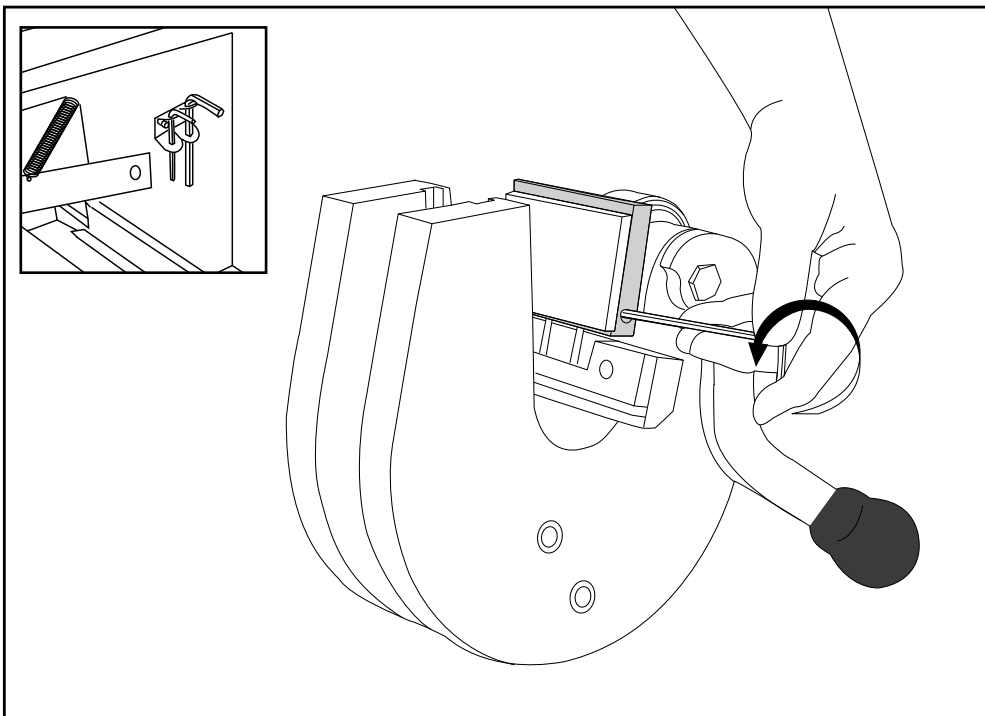

Loosen set screw that holds punchblock in place when repositioning is required.

Work Preparation and Replacing Punchboards

A5

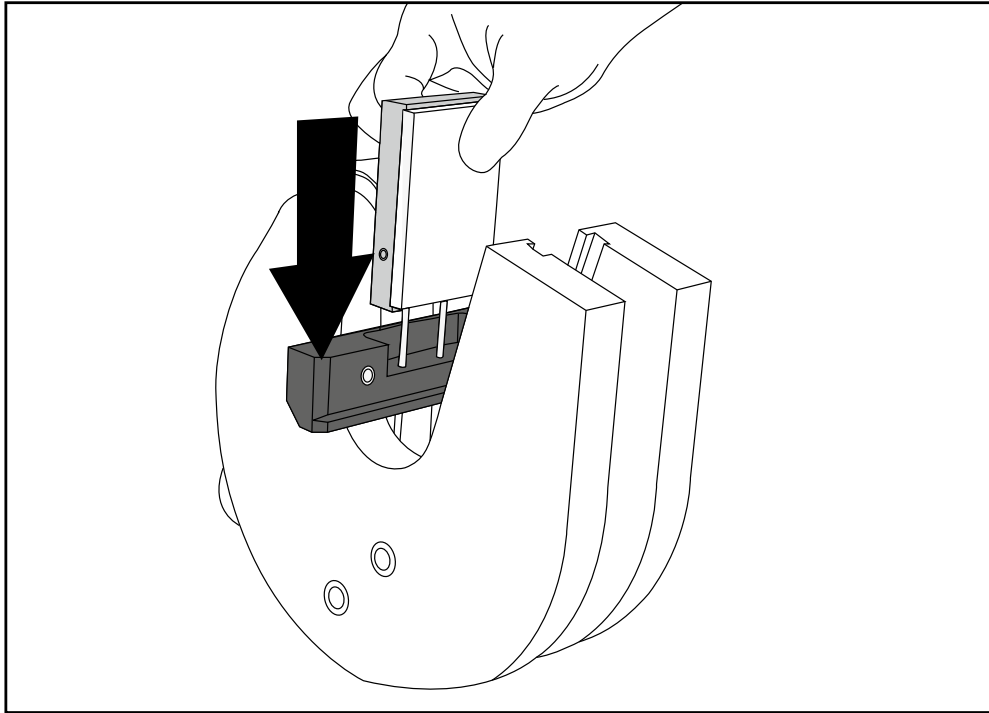

Slide punchblock over pins.

A6

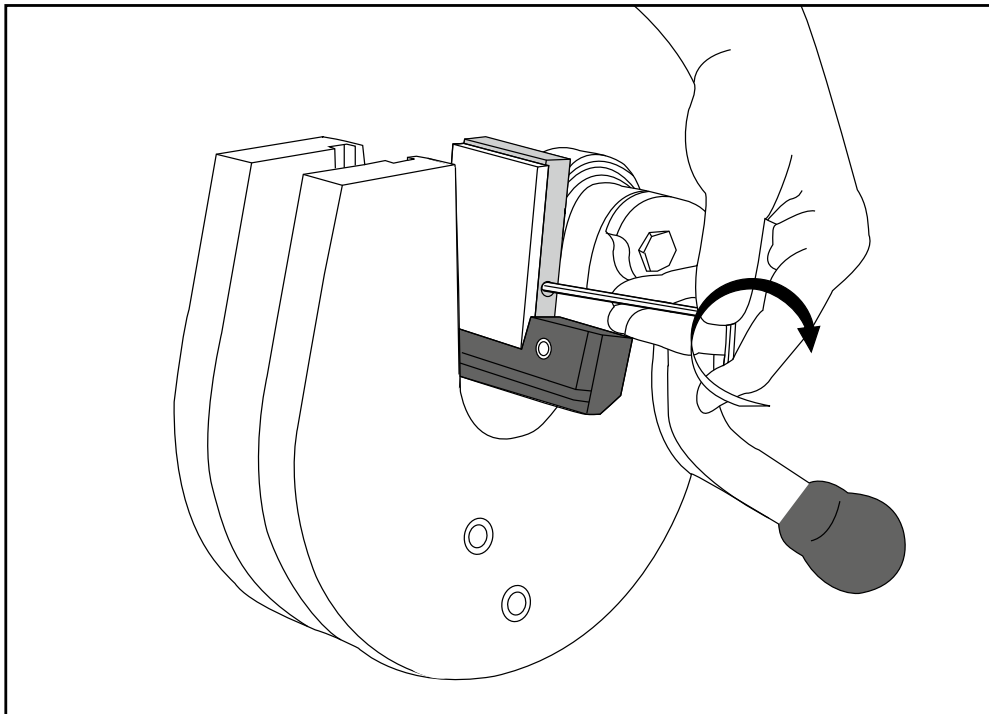

Secure punchblock with set screw.

Work Preparation and Replacing Punchboards

A7

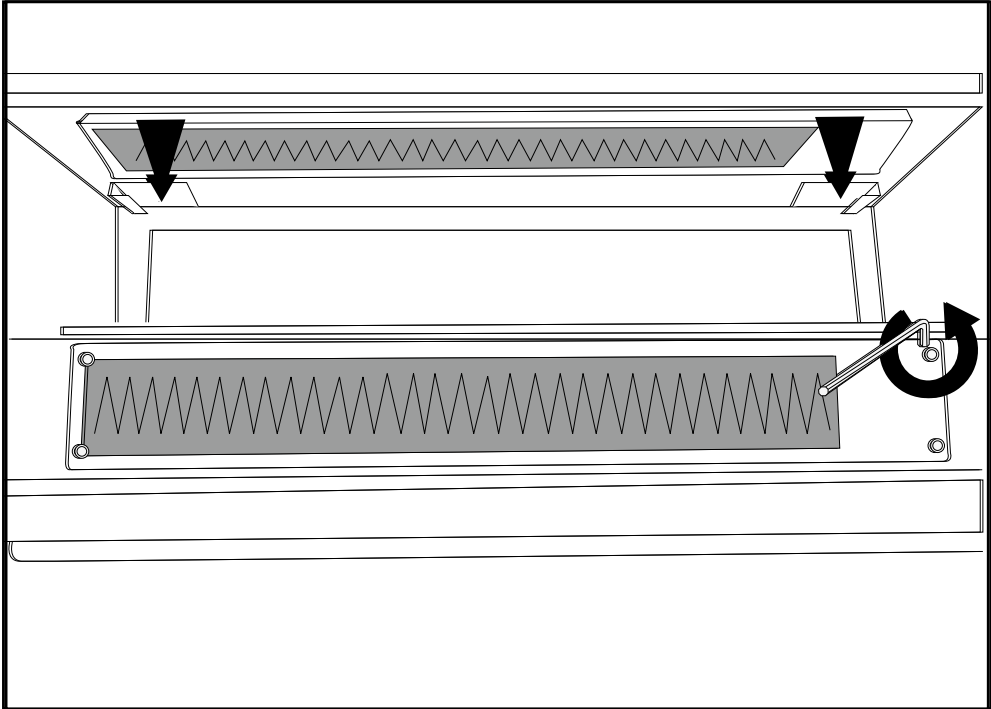

Replace punchboard by unscrewing the four hex bolts. Stow unused punchboard in holder on the back.

A8

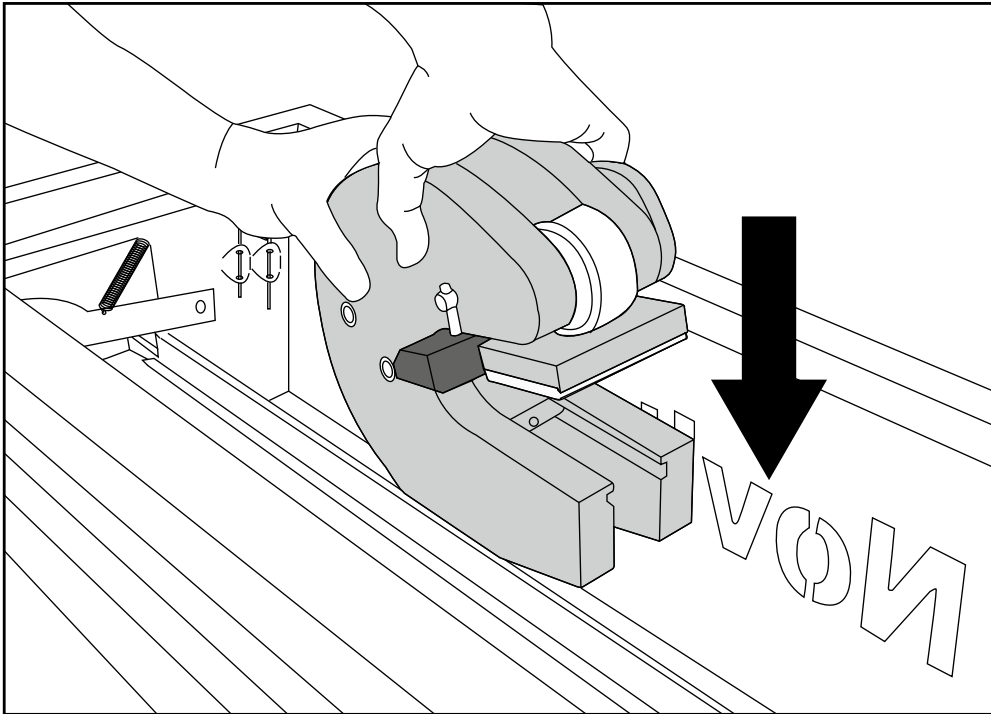

Reinstall C-frame.

Work Preparation and Replacing Punchboards

A9

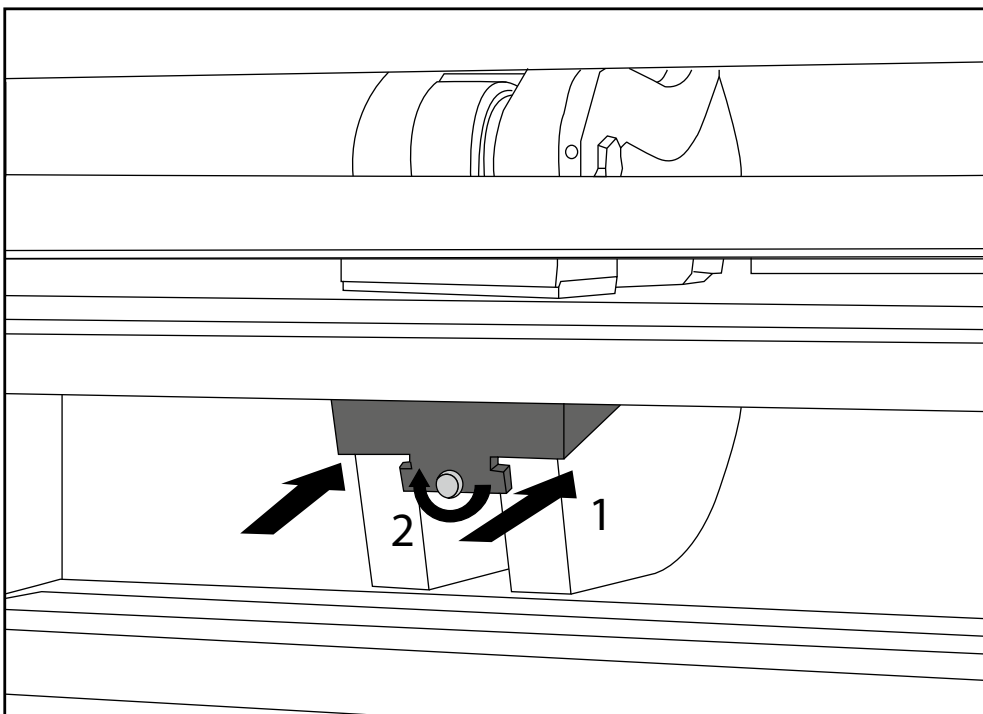

Secure C-frame. 1. Reinstall C-frame wedge. 2. Turn the fixation screw to the right. **Attention: The screw is also used to adjust punching force.**

A10

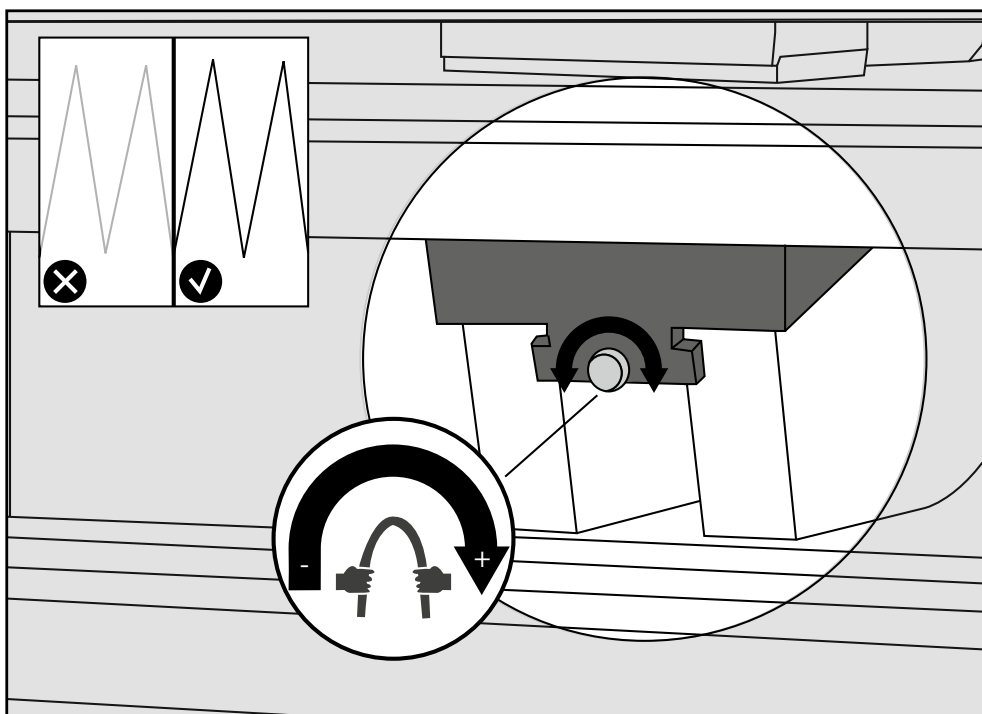

Turn fixation screw clockwise to increase punch cutting force.

Punching Single Fingers



Prior to punching ensure:

- The punchblock is in the right position (A3)
- The correct punchboard is installed (A7)
- The punch force has been adjusted for material (A10)

B1

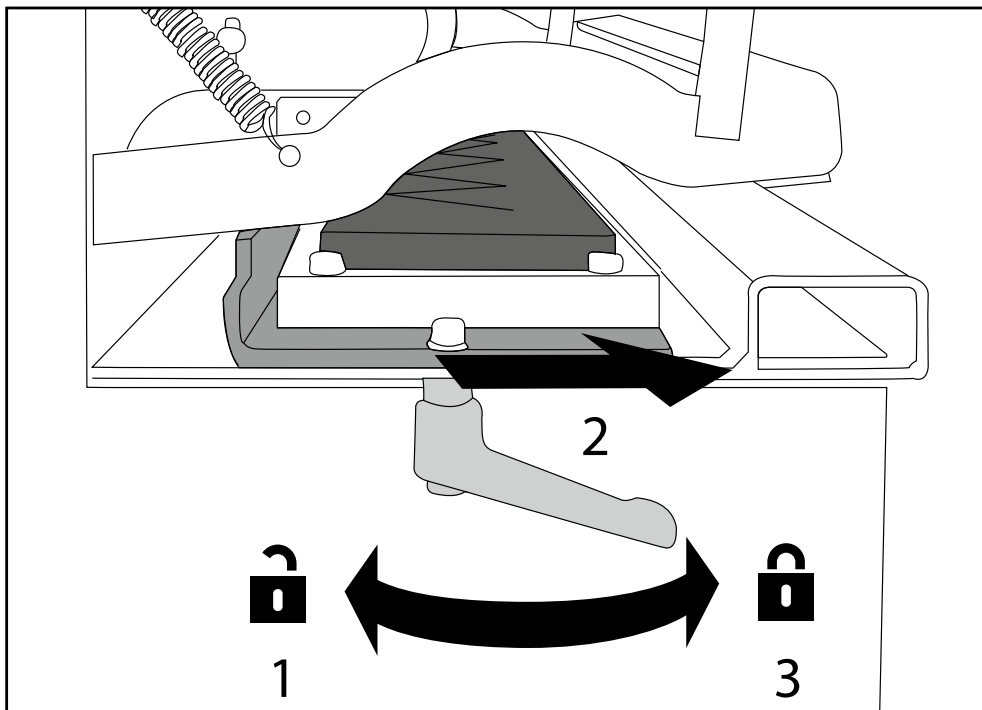

1. Unlock punchboard tray at both ends. 2. Move punchboard tray to front most position. 3. Lock punchboard tray at both ends.

Attention: When required, reposition lock handle (A11).

Punching Single Fingers

B2

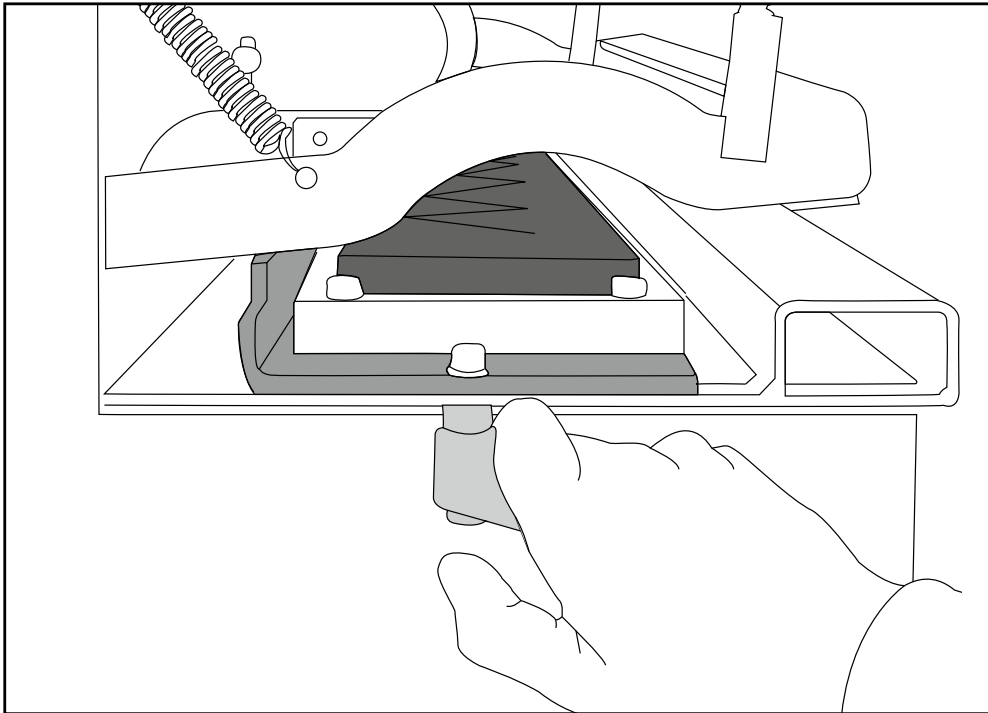

Pull lock handle down if repositioning is required to firmly lock tray.

B3

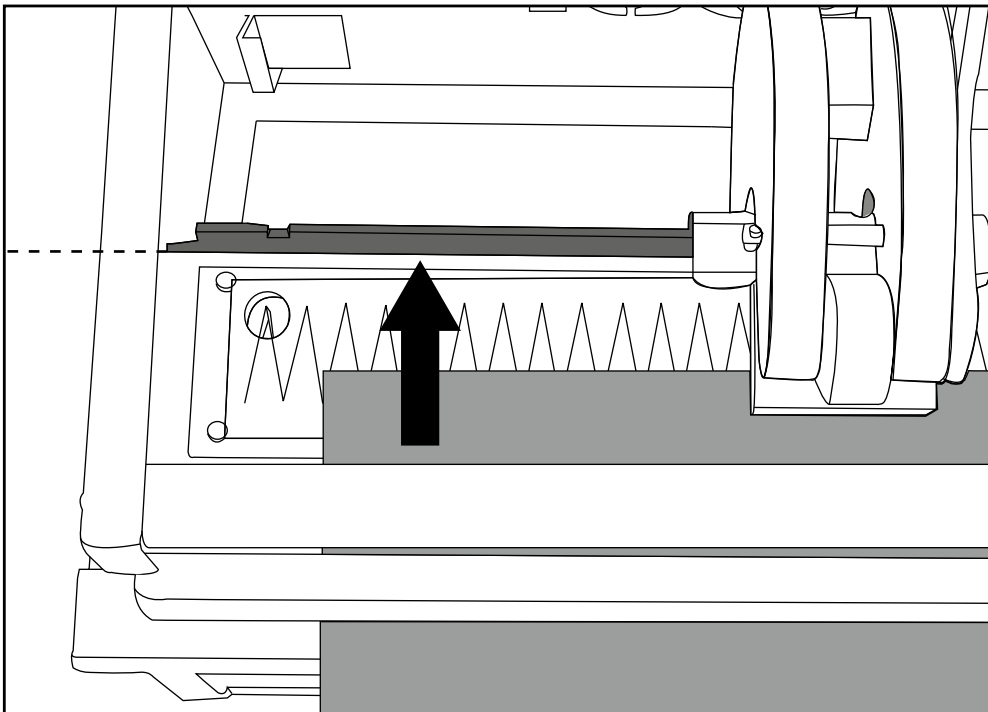

Insert belt until flush against belt stop.

Punching Single Fingers

B4

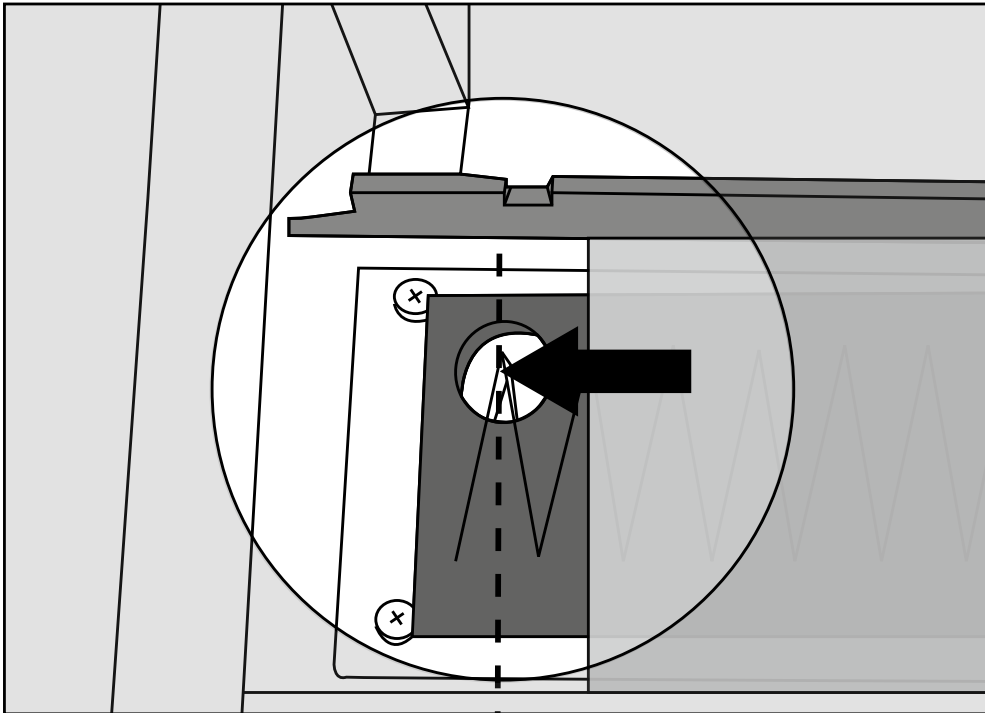

Left align belting material with top of V-Pattern in knife set.

B5

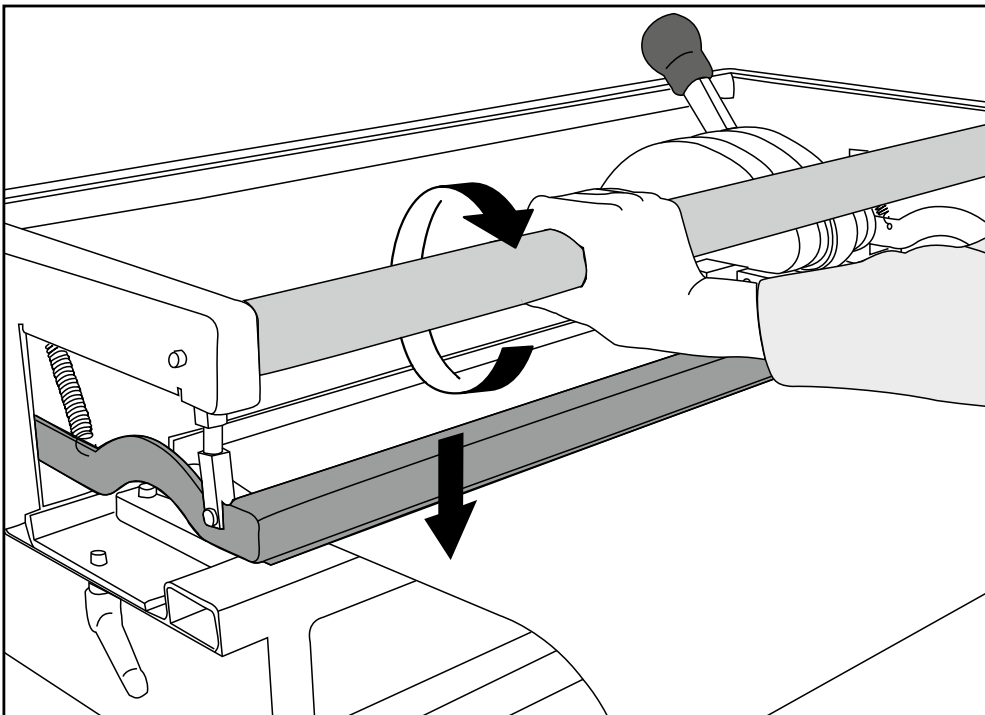

Turn belt clamp bar to clamp belt.

Punching Single Fingers

B6

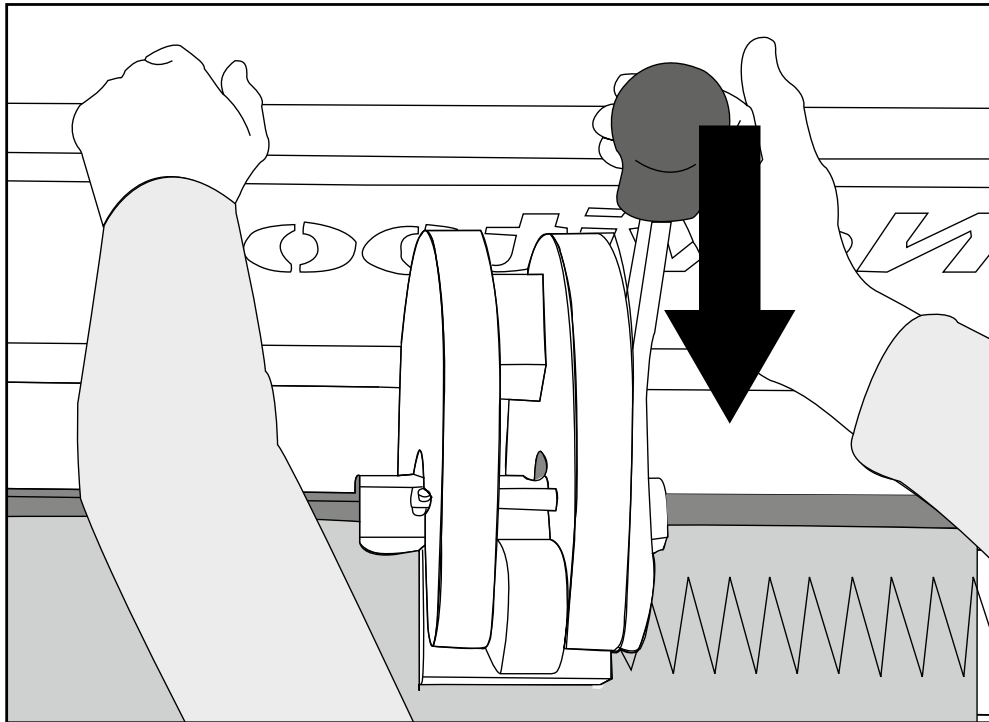

Place left hand on rear frame for support. Use other hand to operate lever to punch belt. Punch in center, at both ends, and then across remainder of material. Remove excess punched material.

B7

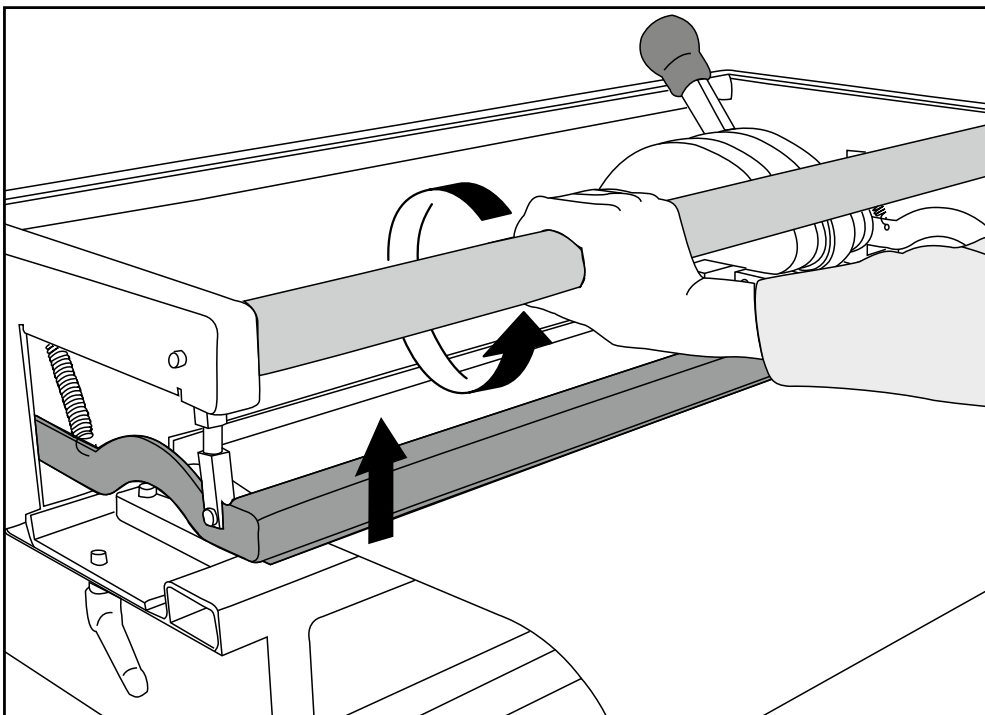

Turn belt clamp bar. Remove belt.

Punching Single Fingers

B8

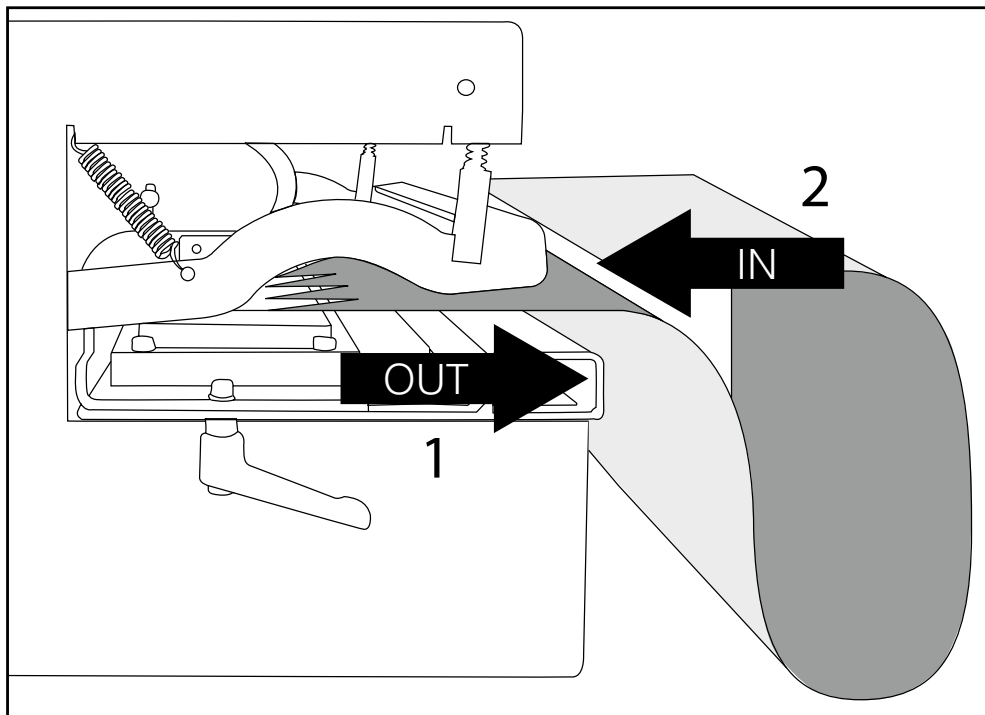

Remove punched belt end. Install opposite belt end with cover side down into the machine.

B9

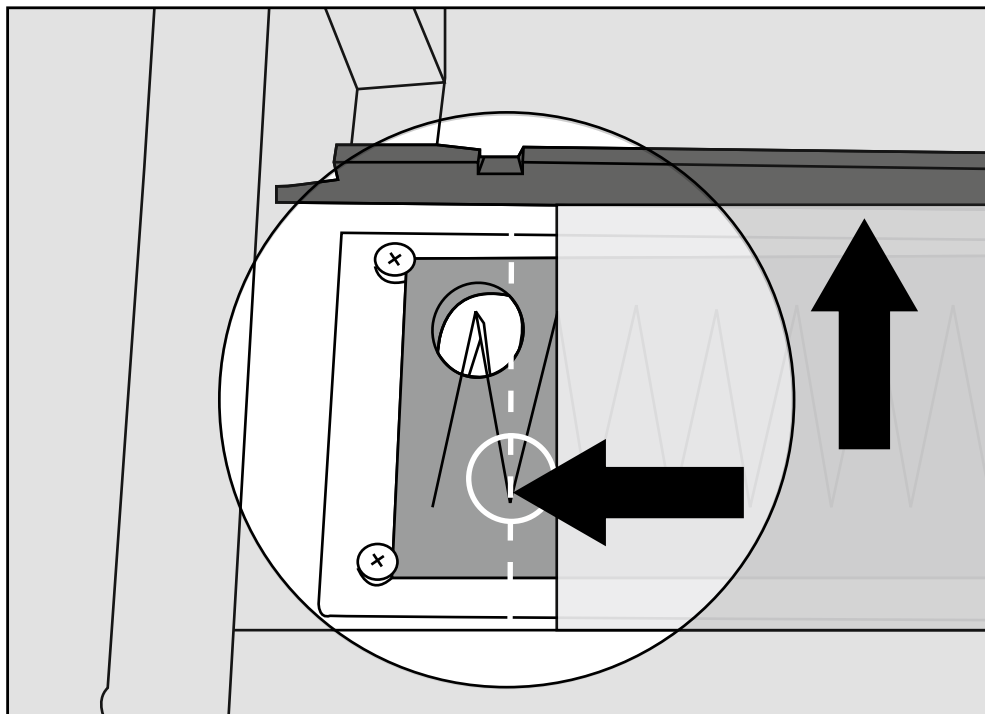

Insert belt end until flush with belt stop. Left align belt with the bottom of V-Pattern in knife set.

Punching Single Fingers

B10

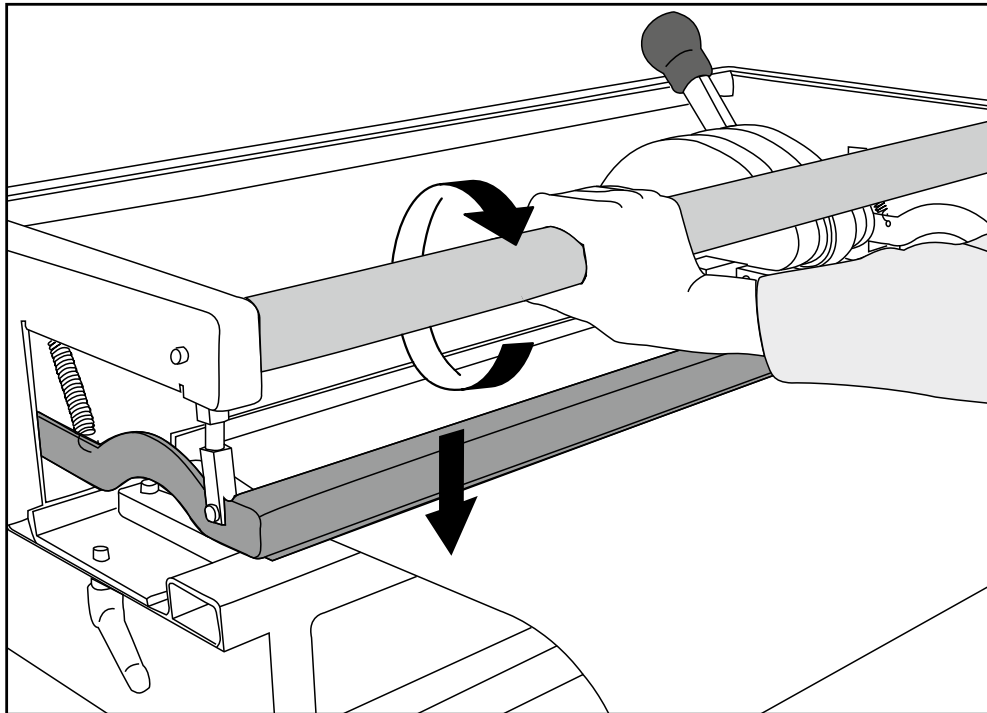

Turn belt clamp bar to clamp belt.

B11

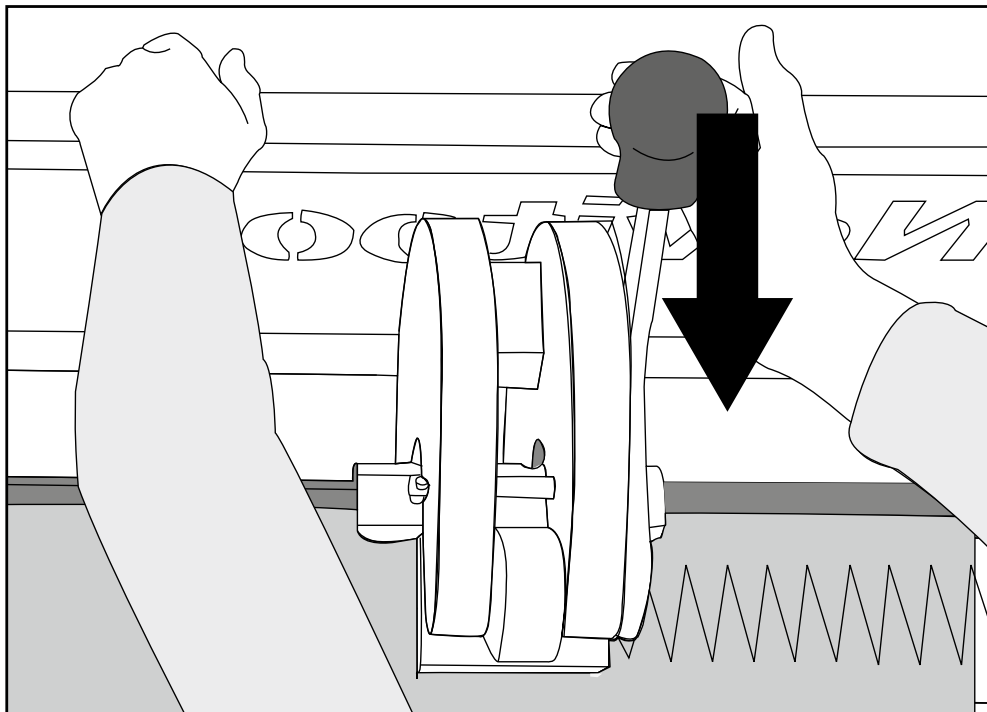

Repeat punching process as shown in B6.

Punching Single Fingers

B12

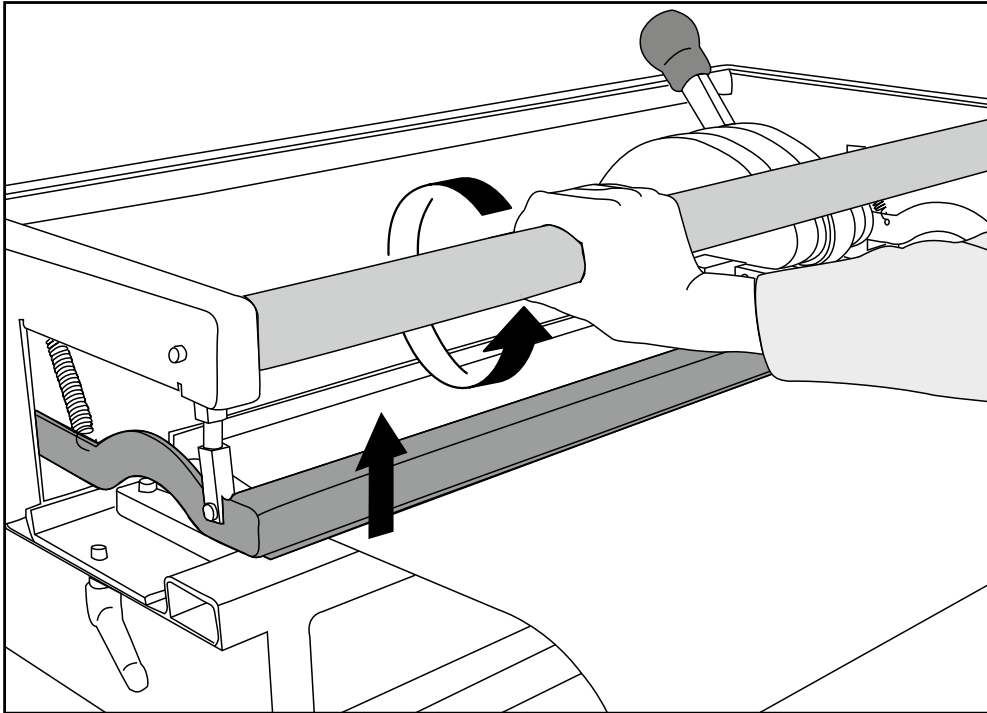

Turn belt clamp bar. Remove belt.

Punching Finger over Finger



Prior to punching ensure:

- The punchblock is in the right position (A3)
- The correct punchboard is installed (A7)
- The punch force has been adjusted for material (A10)
- Make sure belt ends are ply separated

C1

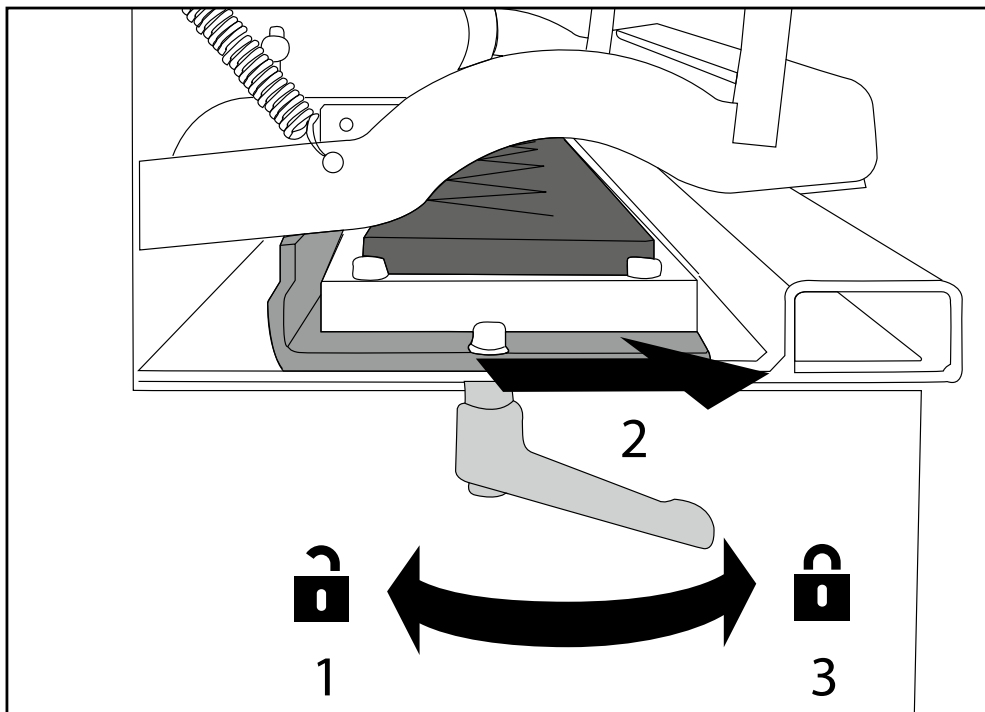

1. Unlock punchboard tray at both ends. 2. Move punchboard tray to front most position. 3. Lock punchboard tray at both ends.

Attention: When required, reposition lock handle (B2).

Punching Finger over Finger

C2

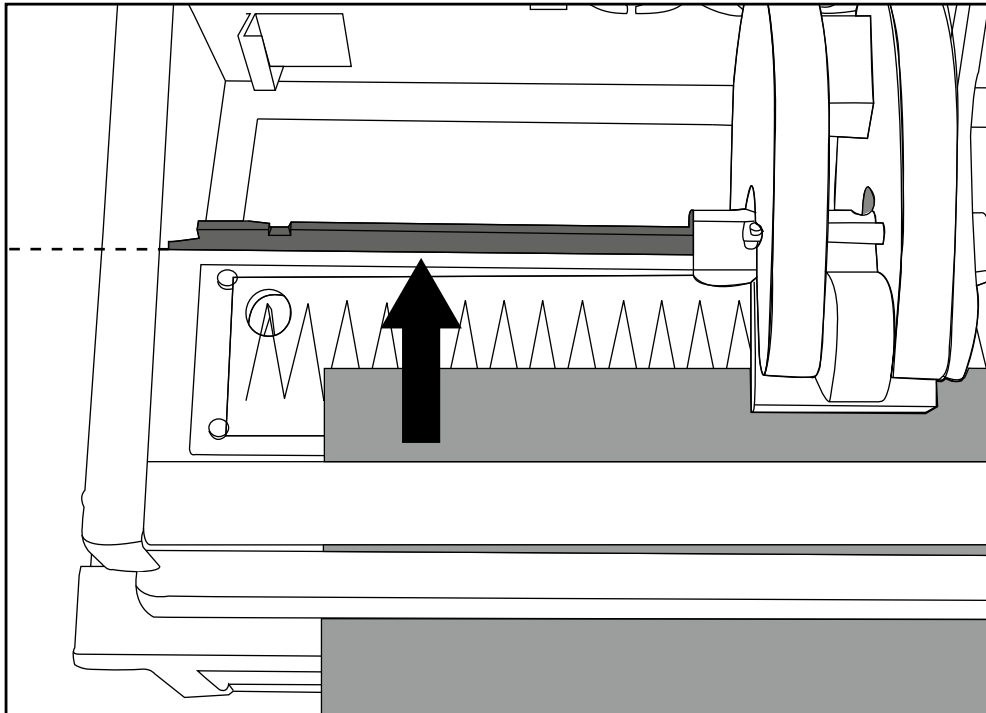

Insert belt until flush against belt stop.

C3

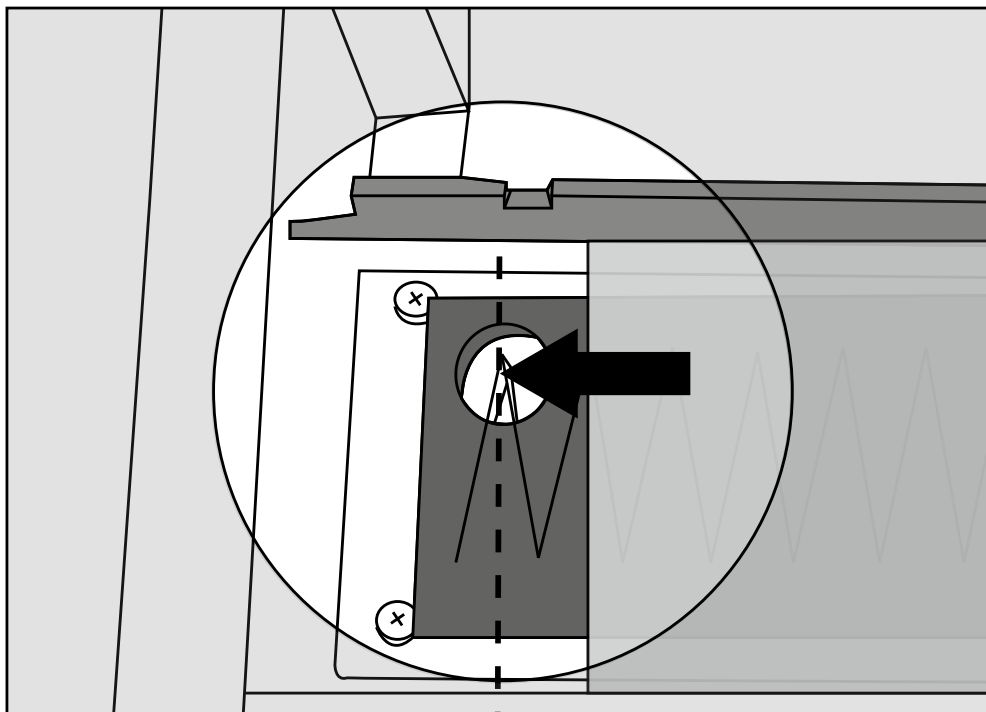

Align belt with top of V-Pattern in knife set.

Punching Finger over Finger

C4

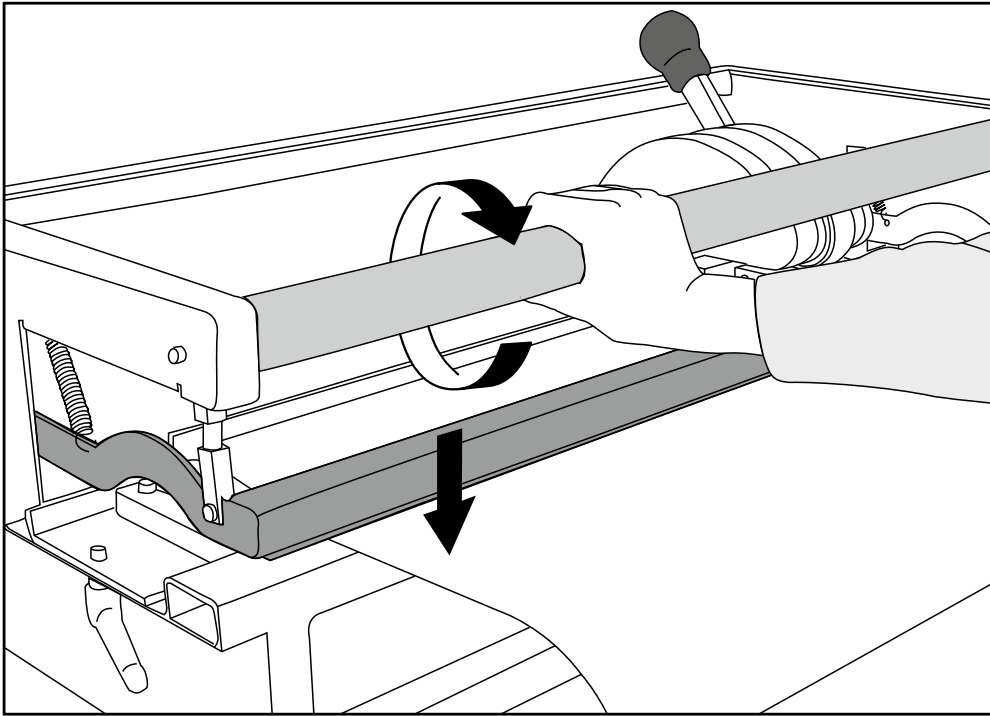

Turn belt clamp bar to clamp belt.

C5

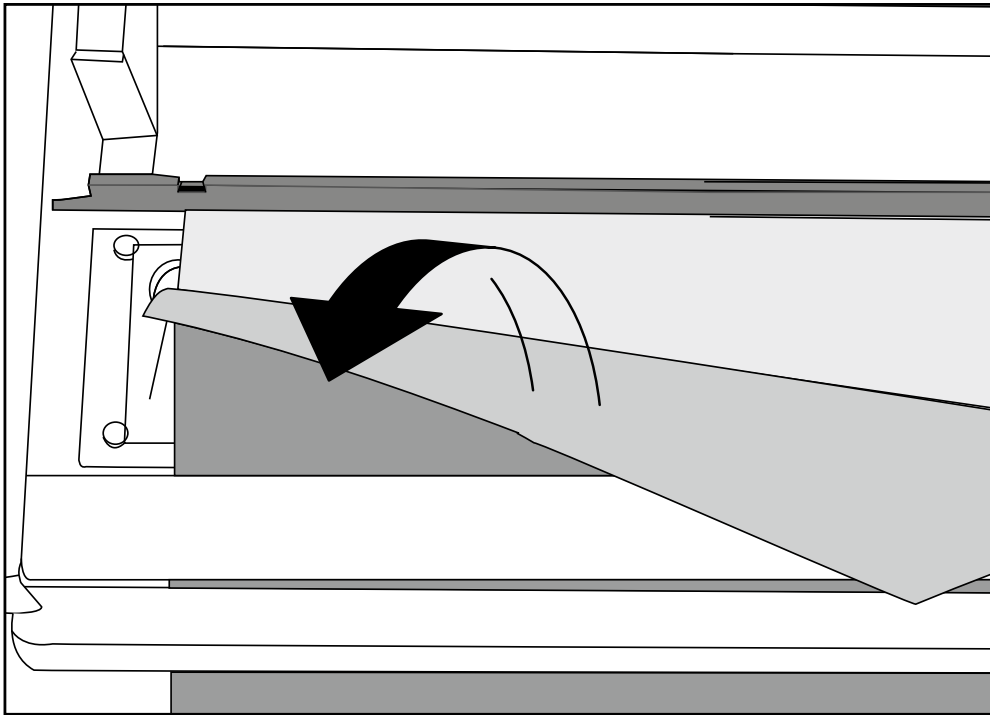

Fold top layer of belt towards you.

Punching Finger over Finger

C6

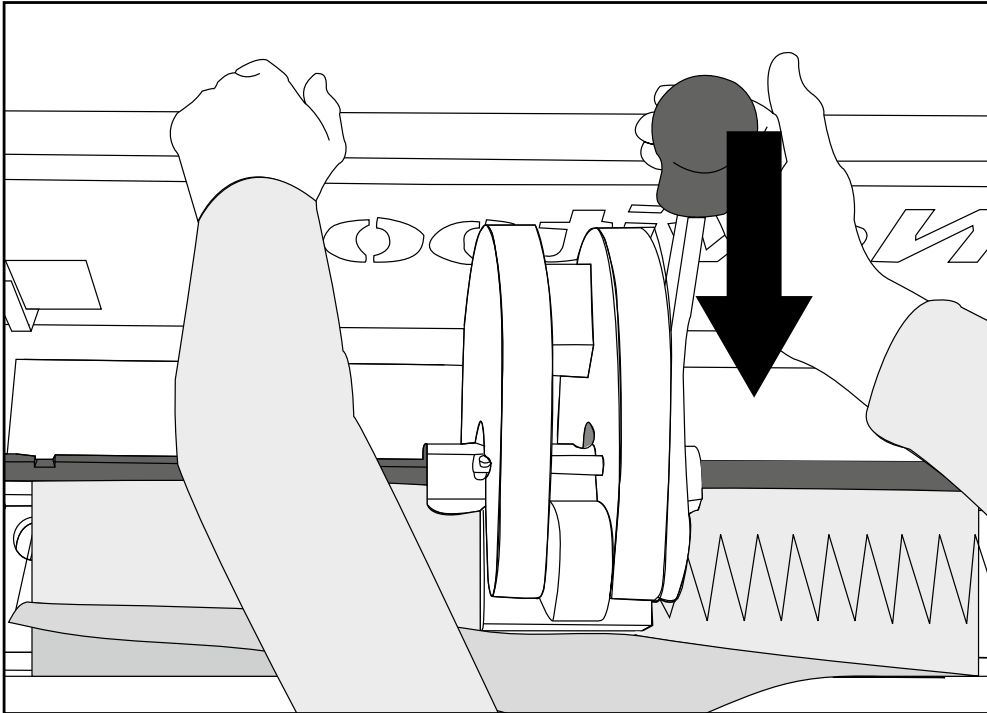

Place left hand on rear frame for support. Use other hand to operate lever to punch belt. Punch in center, at both ends, and then across remainder of material. Remove excess punched material and loosen fingers from punch board prior to sliding back the tray.

C7

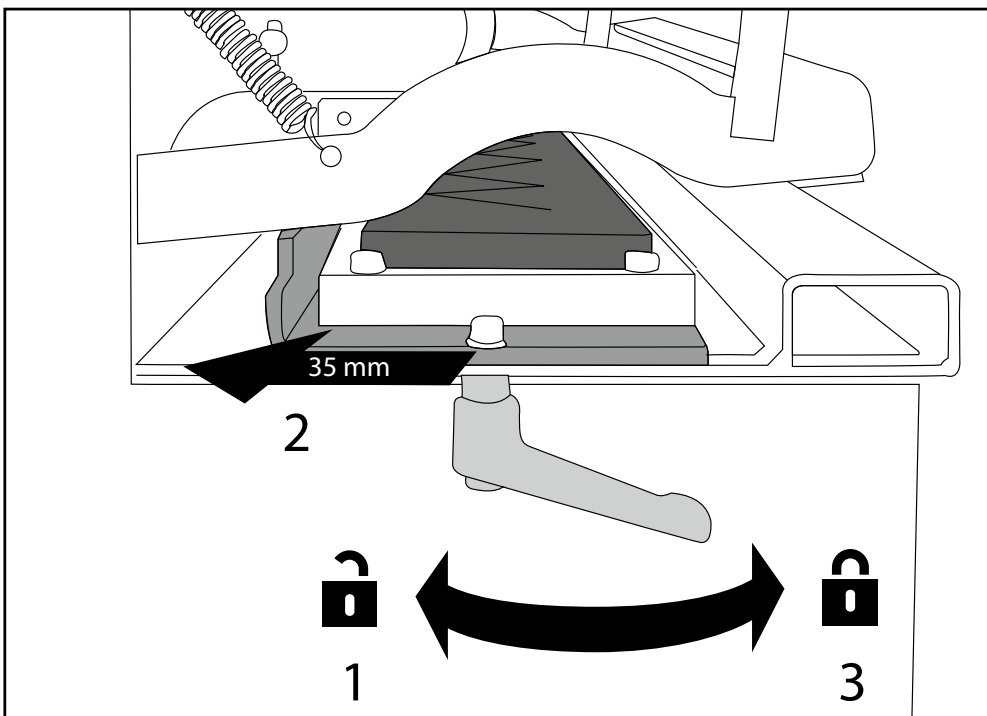

Keep belt clamped. 1. Unlock punchboard tray at both ends. 2. Slide it to the final back position. 3. Lock punchboard tray at both ends.

Punching Finger over Finger

C8

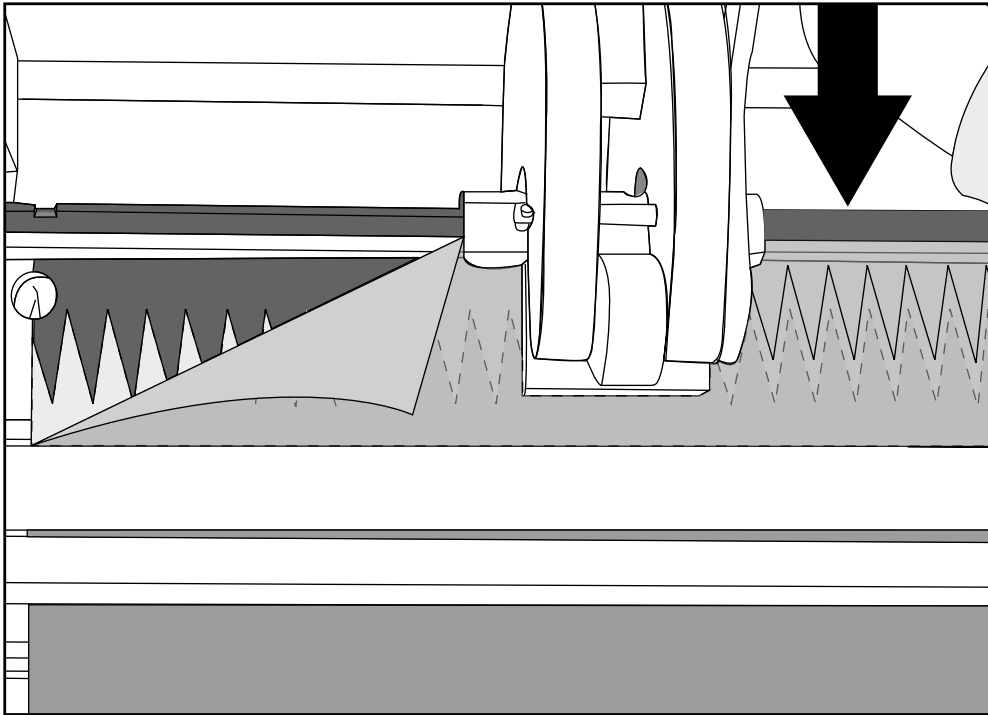

Repeat punching process for second array of fingers. Again remove punched excess material.

C9

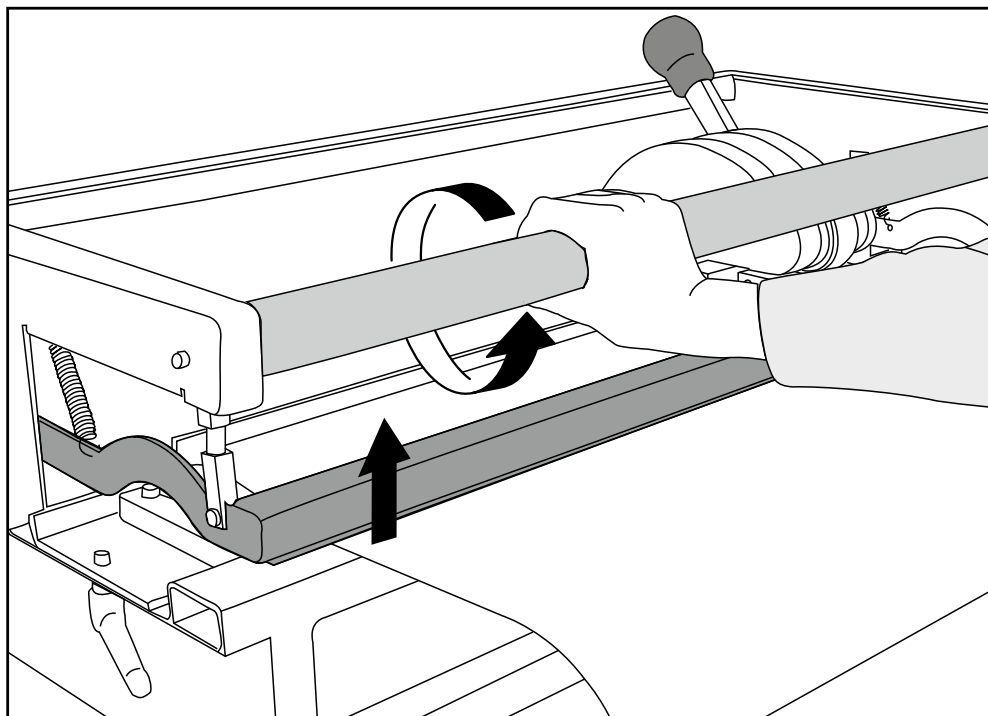

Turn belt clamp bar. Remove belt.

Punching Finger over Finger

C10

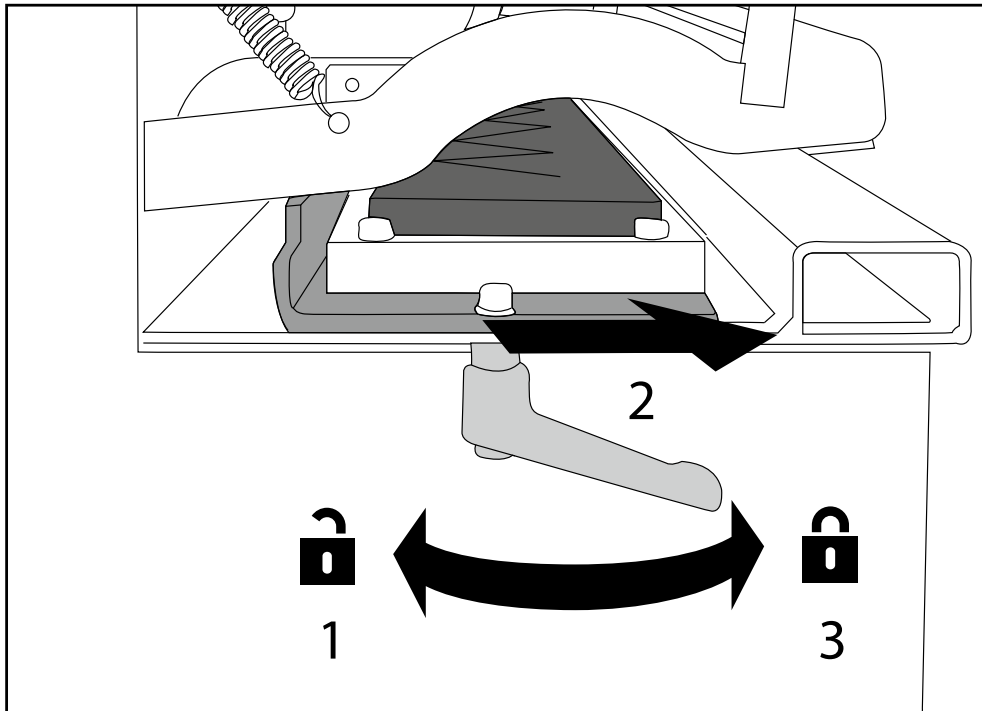

1. Unlock punchboard tray at both ends. 2. Move punchboard tray to front most position. 3. Lock punchboard tray at both ends.

C11

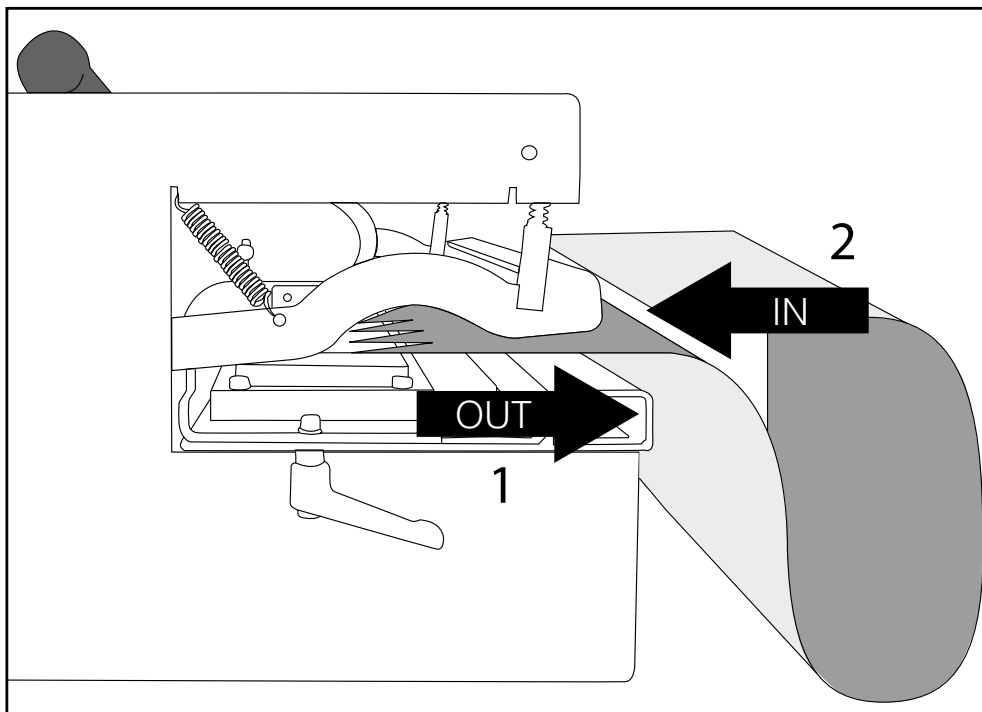

Install opposite belt end with cover side down into the machine.

Punching Finger over Finger

C12

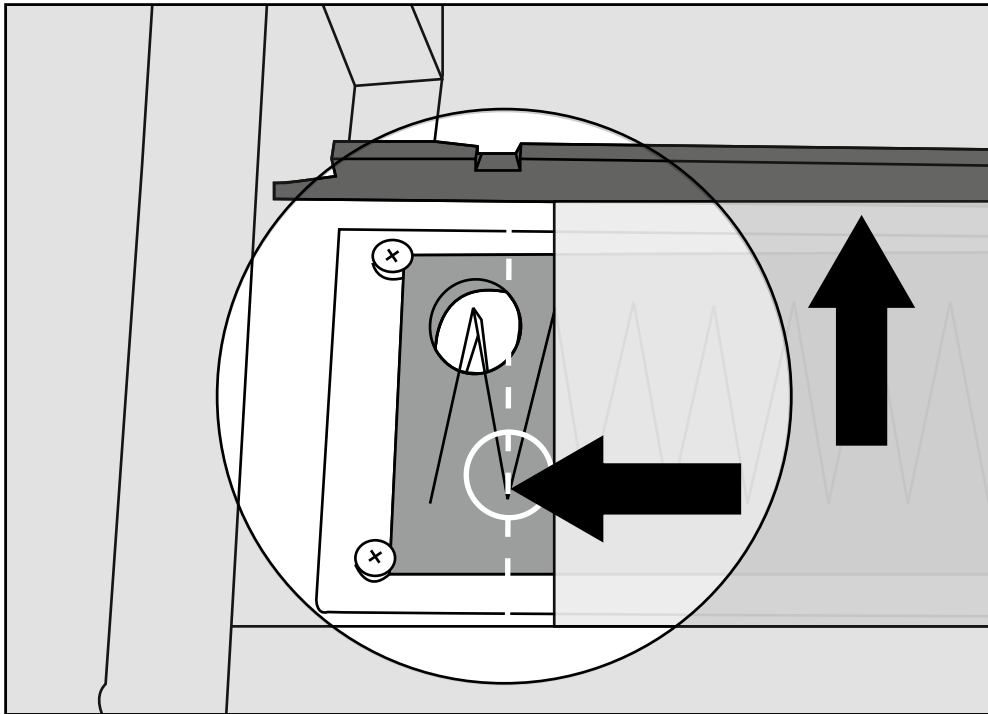

Insert belt end until flush with belt end stop. Left align belting material with bottom of V-Pattern in knife set.

C13

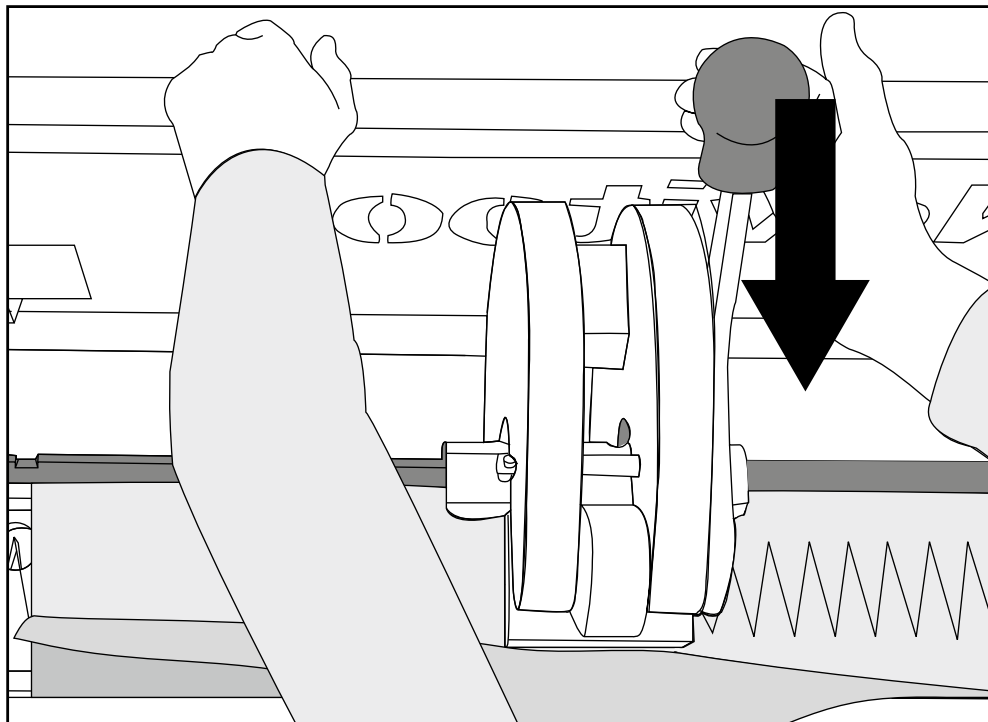

Repeat punching process as shown in C5-C6 for first layer.
Repeat C7-C9 second layer.

Punching Finger over Finger

C14

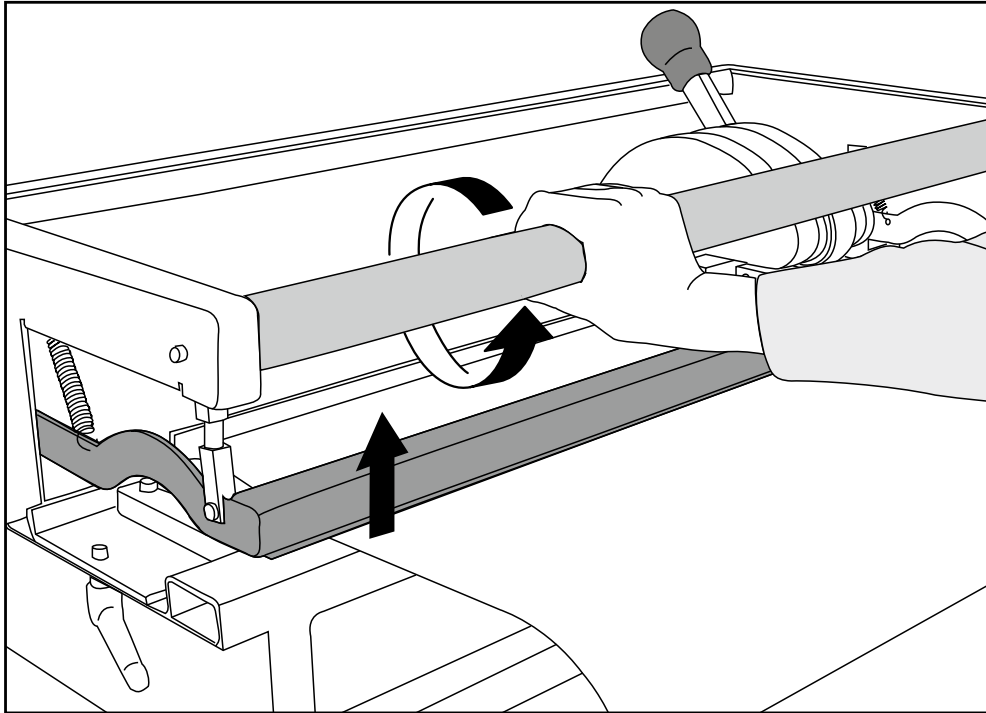

Turn belt clamp bar. Remove belt.

Bias Finger Punching



Prior to punching ensure:

- The punchblock is in the right position (A3)
- The correct punchboard is installed (A7)
- The punch force has been adjusted for material (A10)

D1

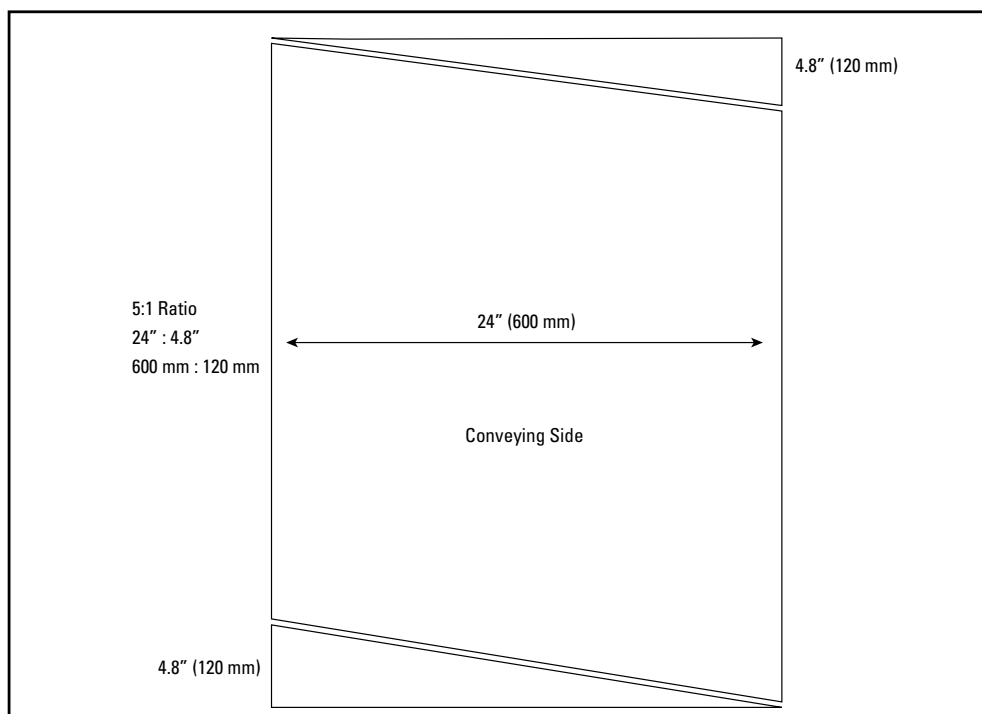

Prepare the belt ends for bias finger punching by cutting opposing (5:1 ratio) angles on each belt end. **NOTE:** Both belt ends will be punched with the conveying side upwards in the PUN M.

Bias Finger Punching

D2

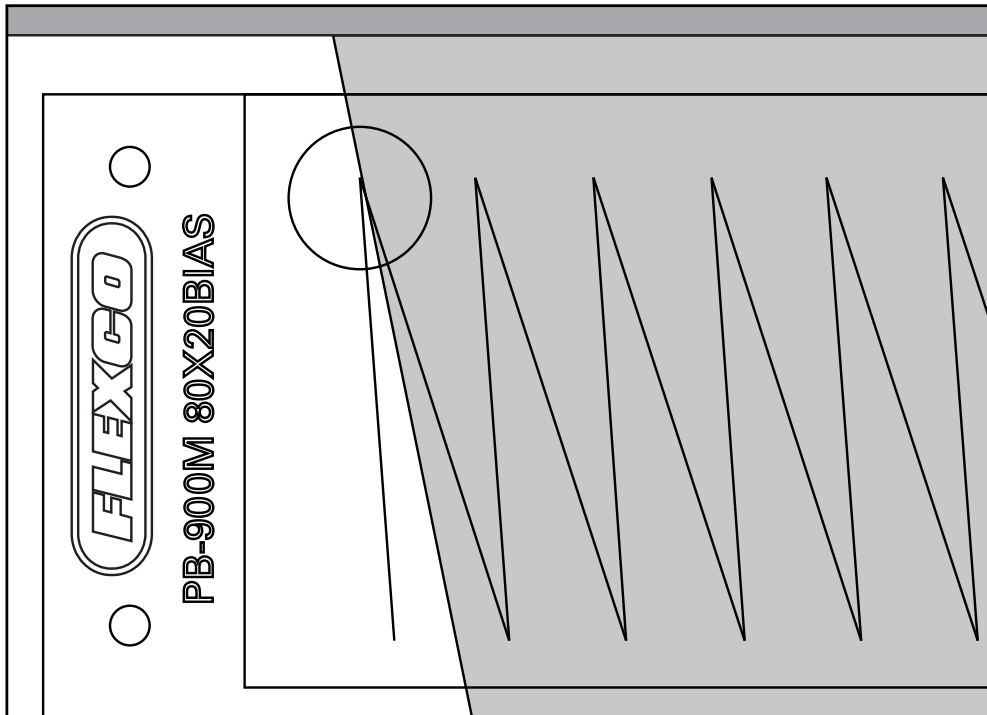

Insert the initial belt end cover side up and flush against belt stop. Align the left edge of belting with top of V-pattern in knife set.

D3

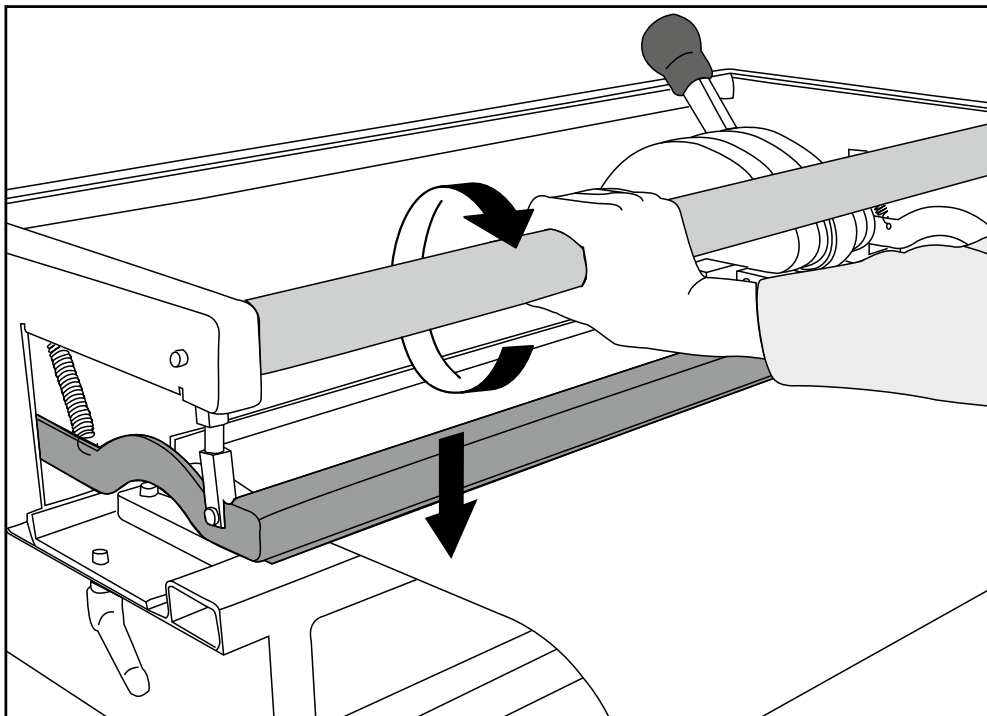

Clamp the belt in place by rotating the belt clamp bar.

Bias Finger Punching

D4

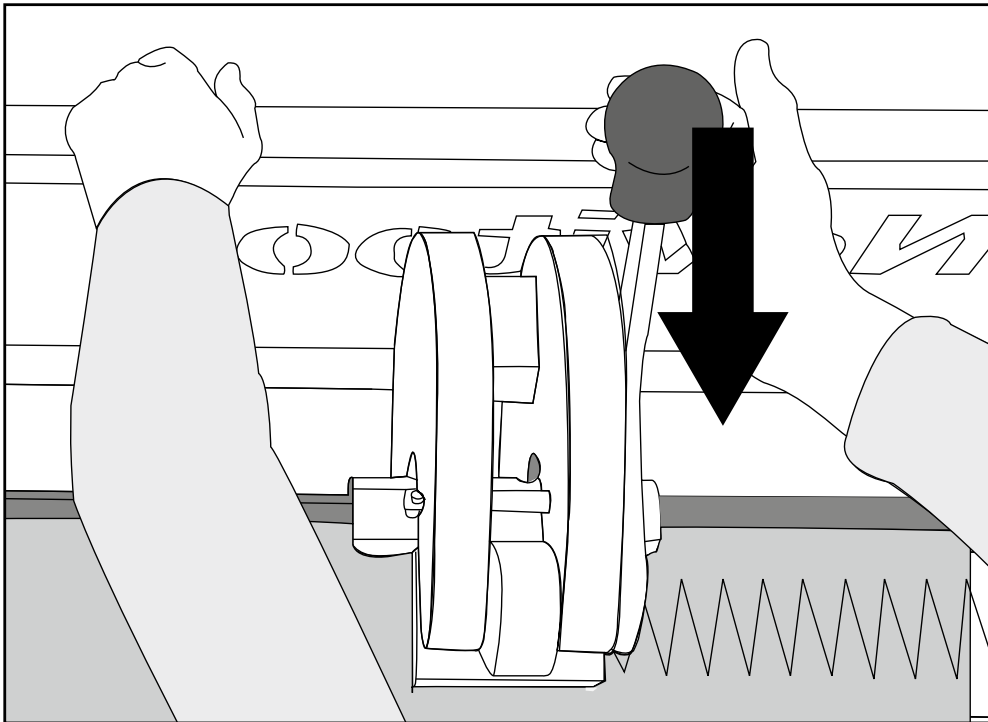

Place left hand on rear frame for support. Use other hand to operate lever to punch belt. Punch in center, at both ends, and then across remainder of material. Remove excess punched material.

D5

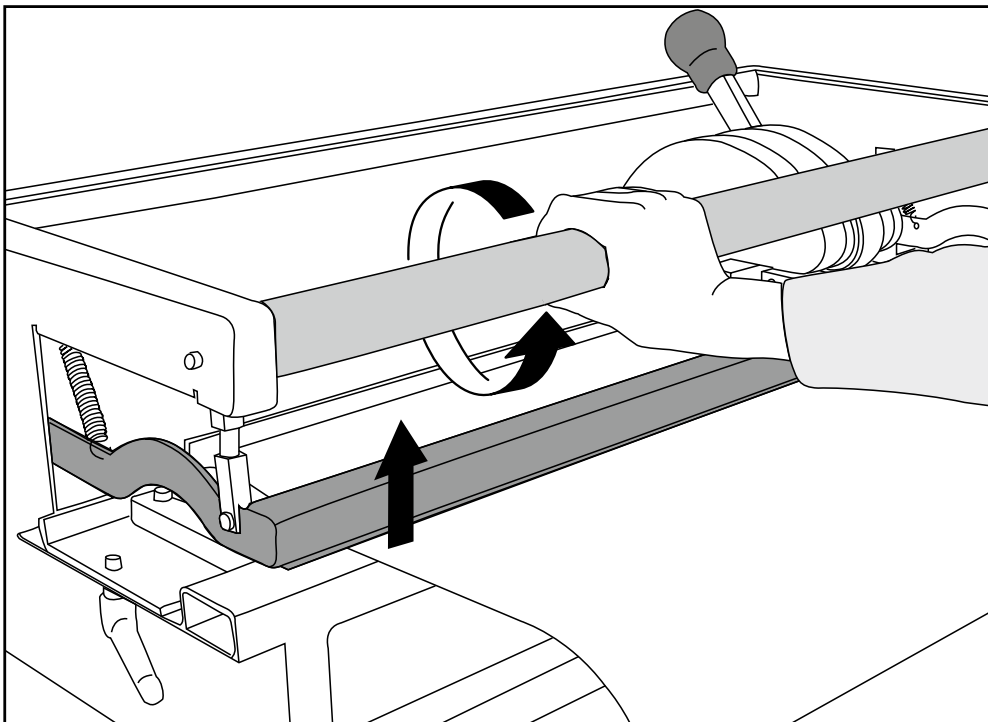

Turn belt clamp bar. Remove belt.

Bias Finger Punching

D6

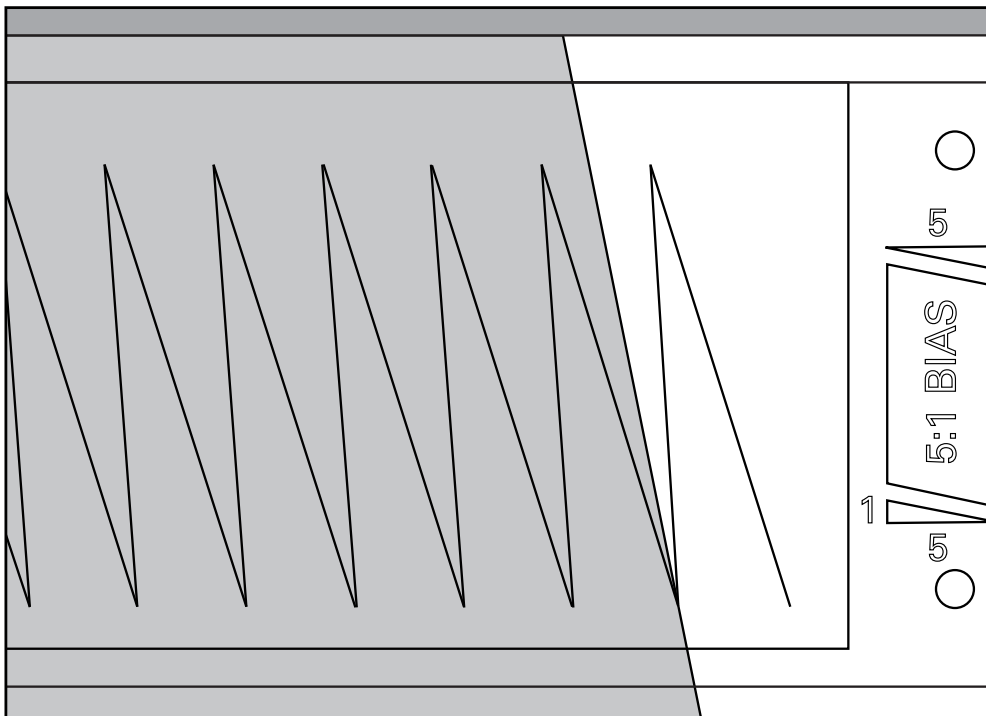

Insert the opposite belt end cover side up into the Punch. Flush against belt. Align right belt edge with bottom of V-pattern in knife set.

D7

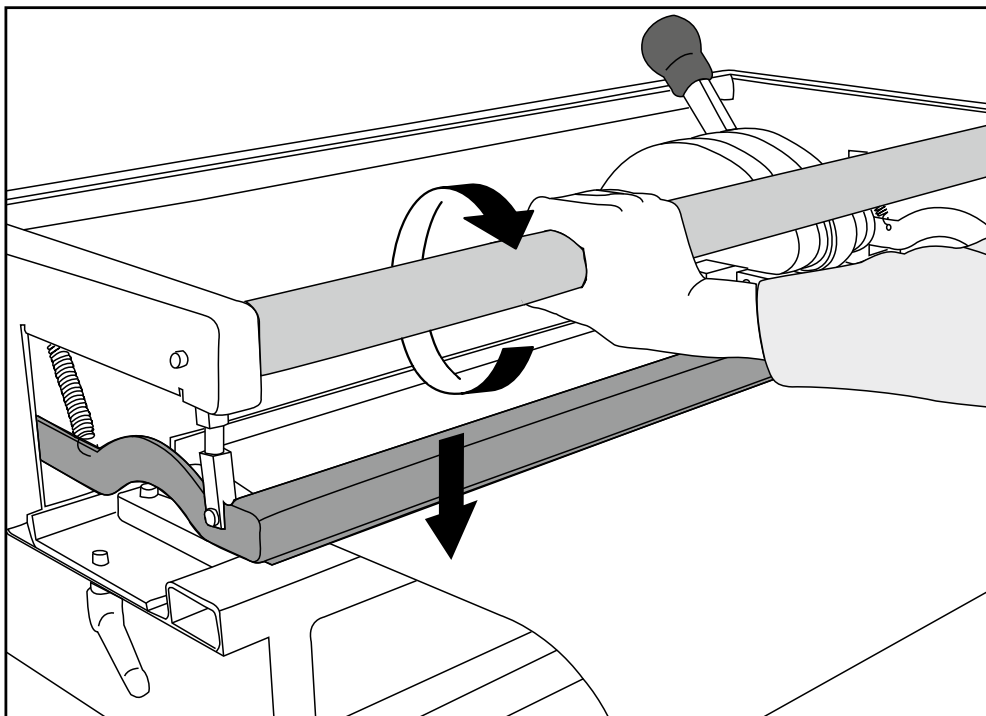

Turn belt clamp bar to clamp belt.

Bias Finger Punching

D8

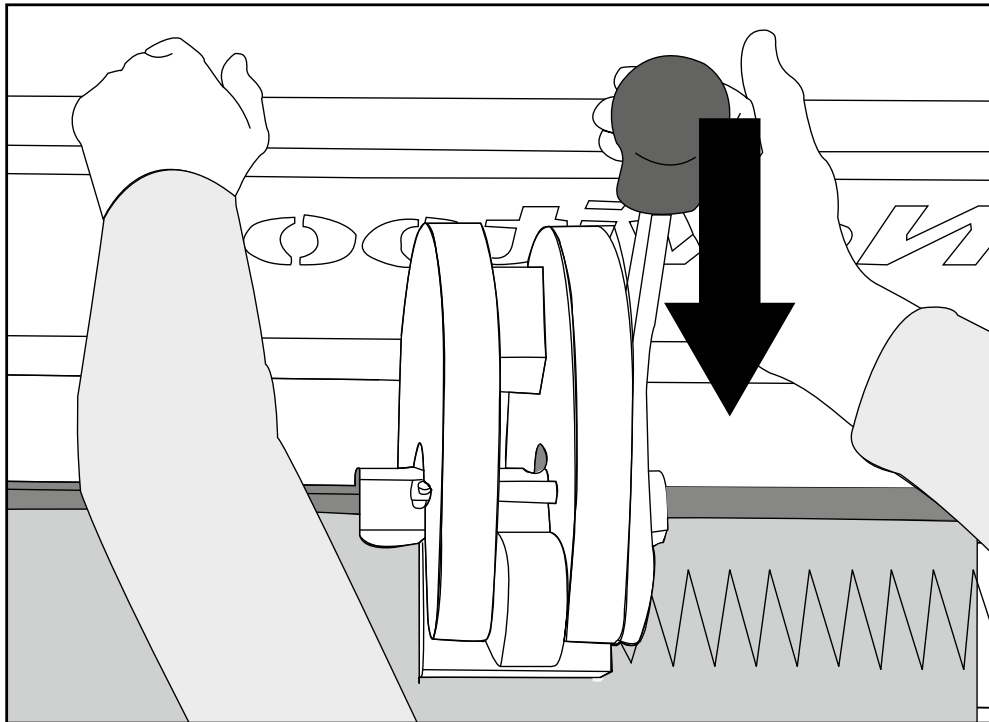

Clamp the belt in place by rotating the belt clamp bar. Punch in center, at both ends, and then across remainder of material.

D9

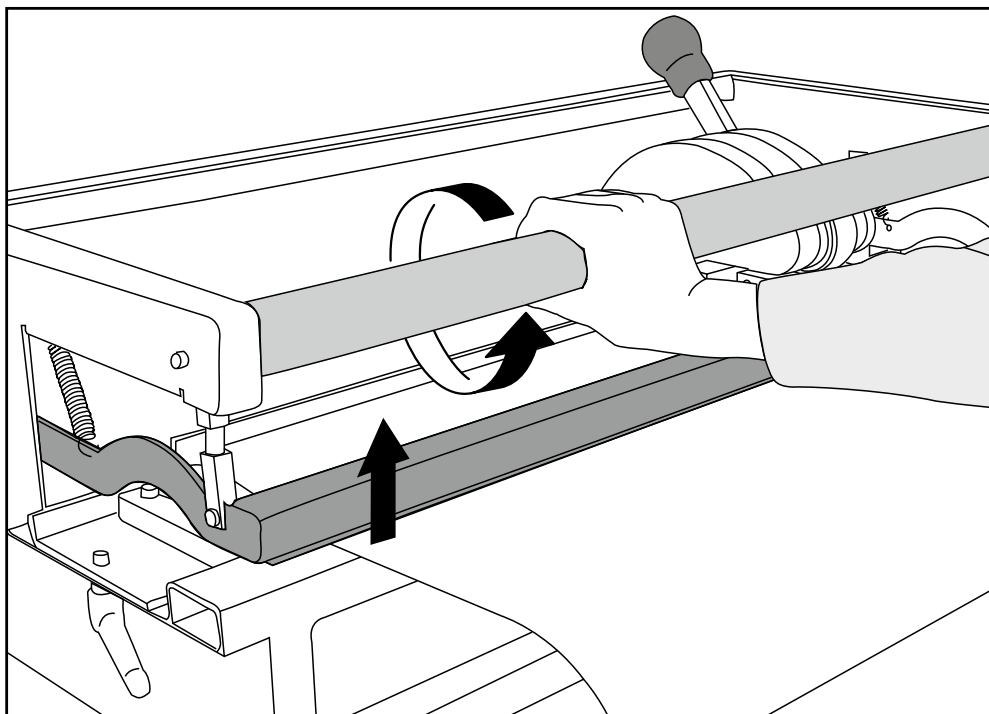

Turn belt clamp bar. Remove belt.

Bias Finger Over Finger Punching



Prior to punching ensure:

- The punchblock is in the right position (A3)
- The correct punchboard is installed (A7)
- The punch force has been adjusted for material (A10)
- Make sure belt ends are ply separated.

E1

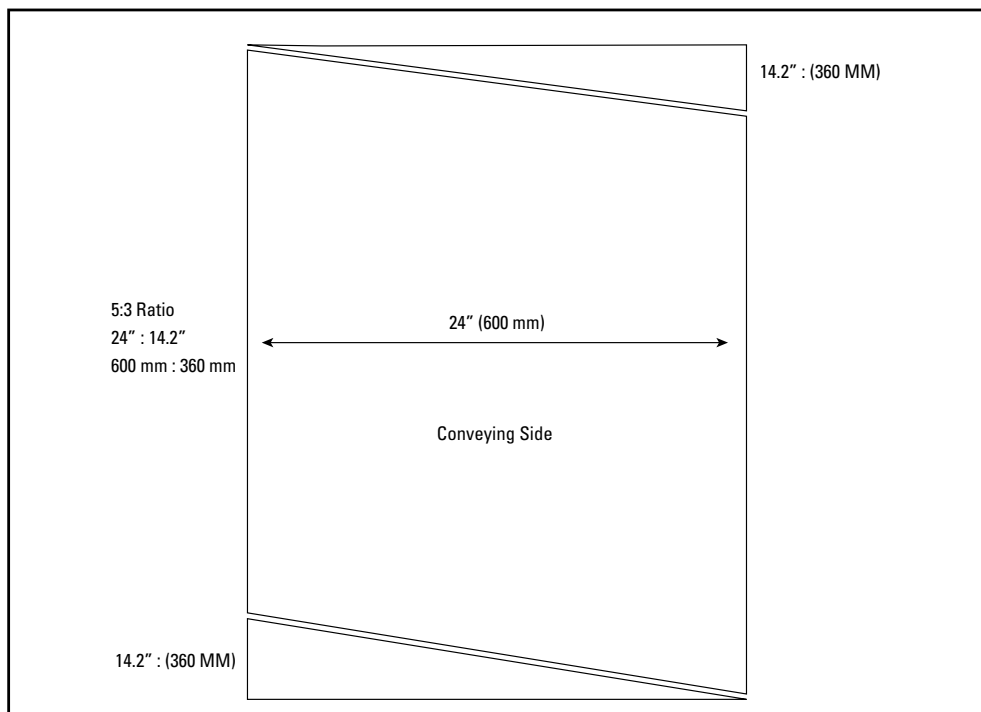

Prepare the belt ends for bias finger over finger punching by cutting opposing (5:3 ratio) angles on each belt end. Use the Ply 130™ to separate each belt end to 4.3" (110 mm) depth.

Bias Finger Over Finger Punching

E2

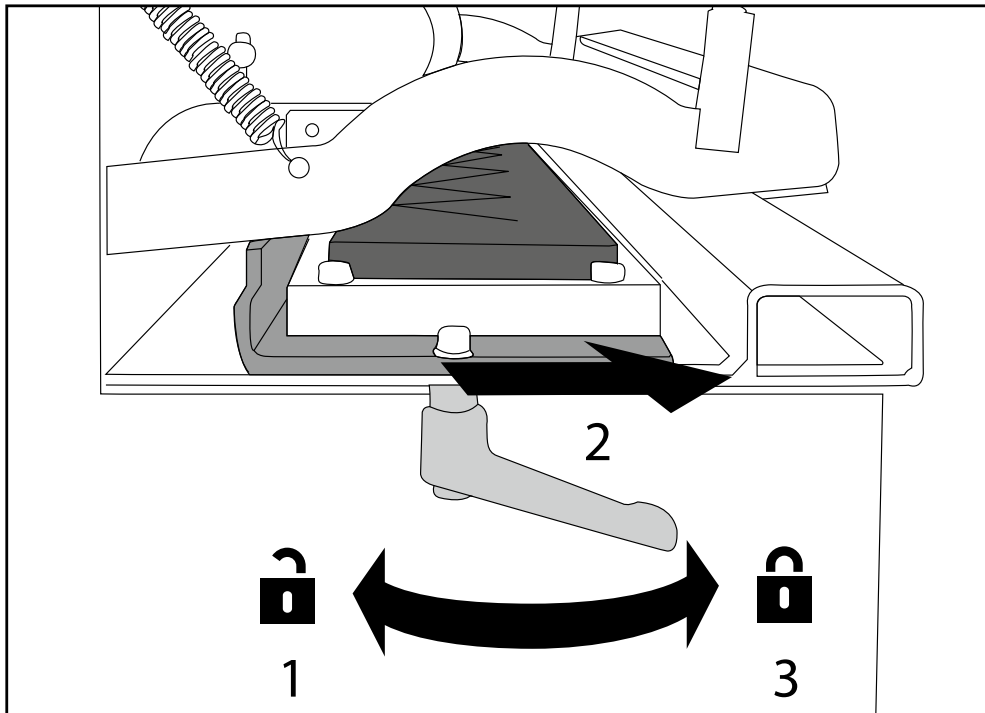

1. Unlock punchboard tray at both ends. 2. Move punchboard tray to front most position. 3. Lock punchboard tray at both ends.

Attention: When required, reposition lock handle (B2).

E3

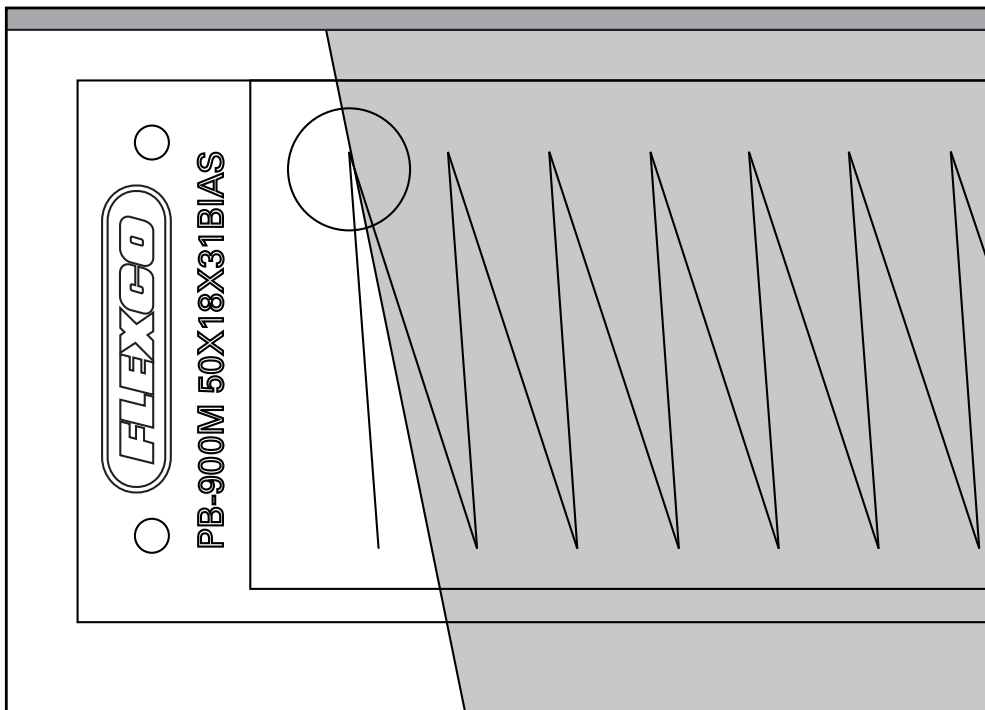

Insert initial belt end cover side up and flush against belt stop. Align the left edge of the belting with the top of V-pattern in knife set.

Bias Finger Over Finger Punching

E4

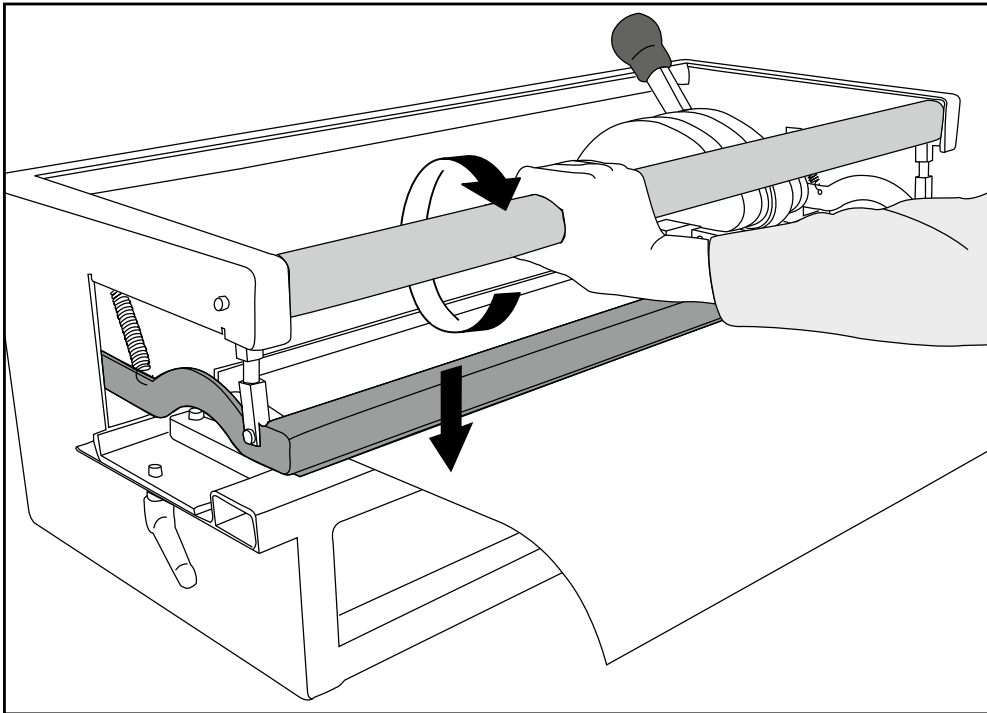

Clamp belt in place by rotating belt clamp bar.

E5

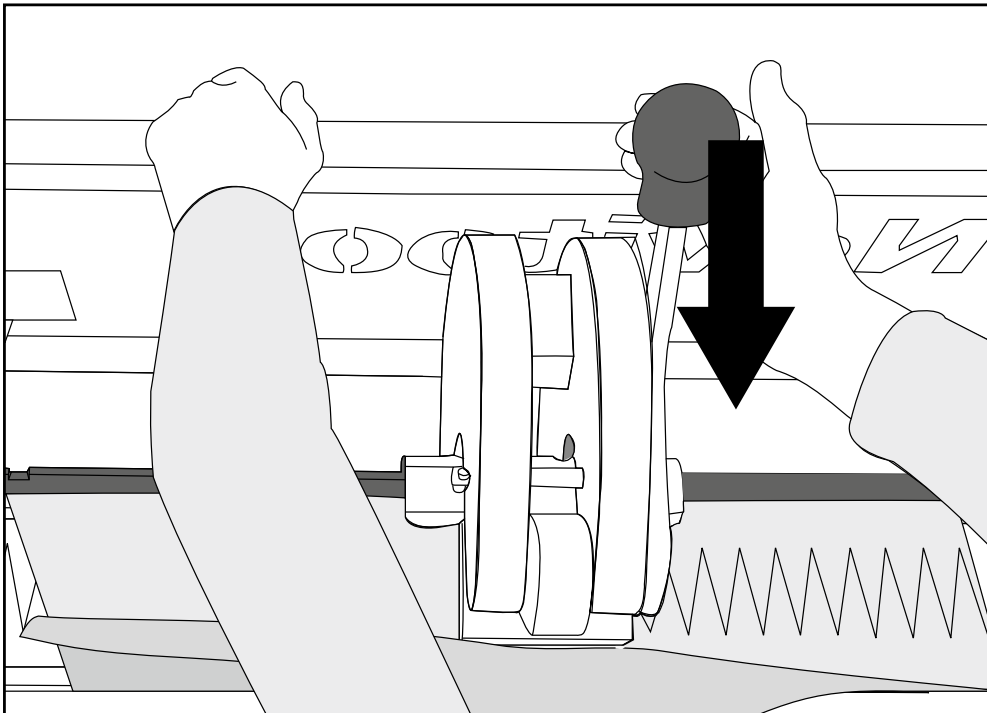

Place left hand on rear frame for support. Use other hand to operate lever to punch belt. Lift top layer of belt up. In this step you will only punch the bottom layer. Punch in center, at both ends, and then across remainder of material.

Bias Finger Over Finger Punching

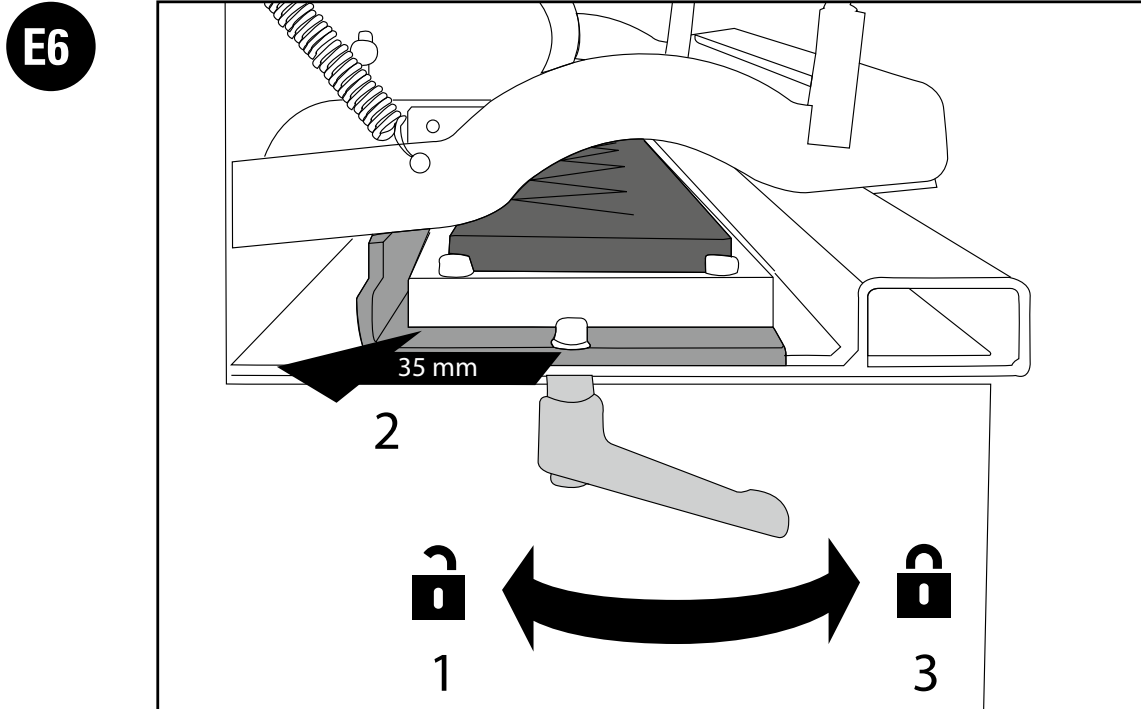

Keep belt clamped. 1. Unlock punchboard tray at both ends. 2. Slide it to final back position. 3. Lock punchboard tray at both ends.

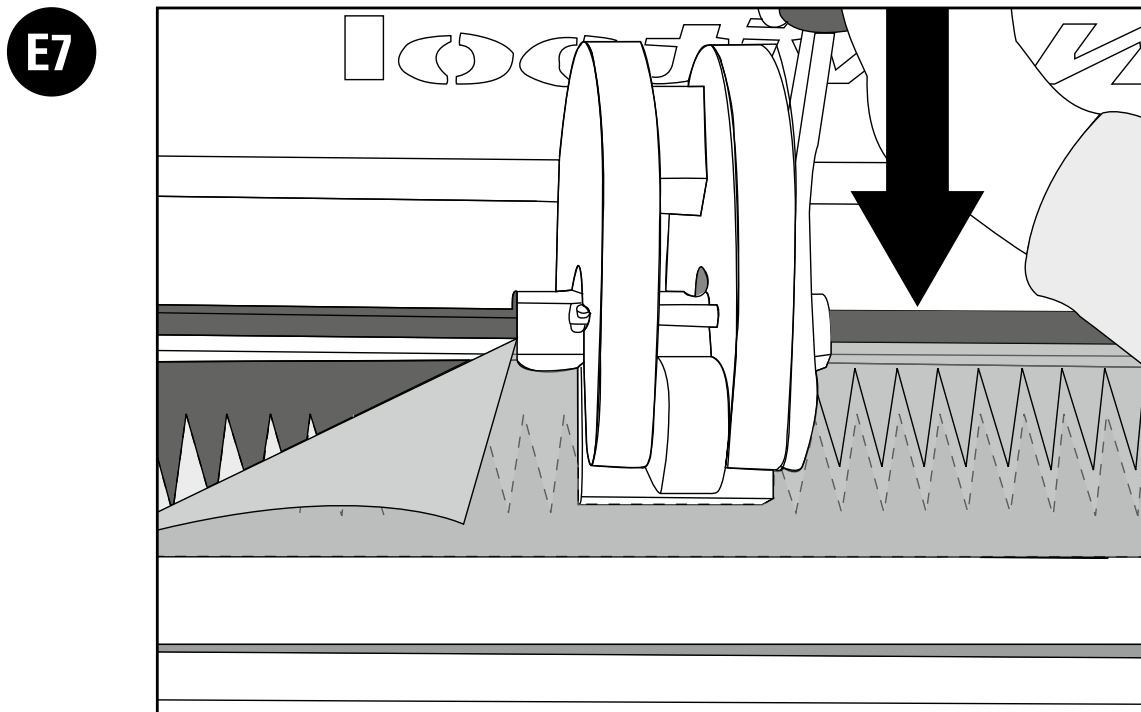

Lay top cover down and repeat punching process for second array of fingers. Remove excess punched material.

Bias Finger Over Finger Punching

E8

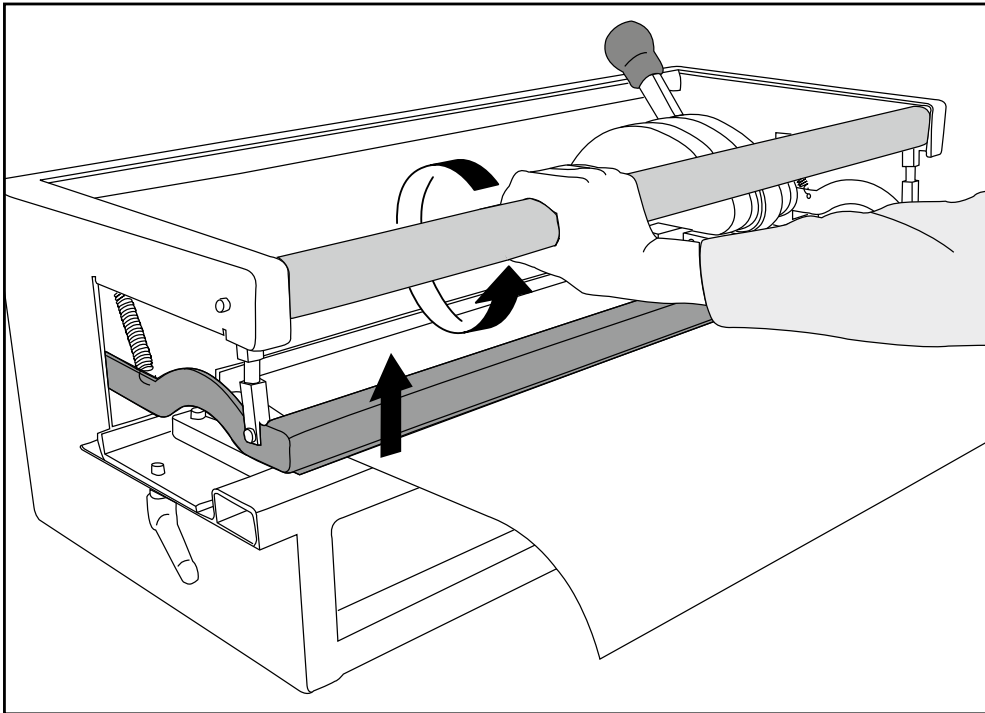

Turn belt clamp bar. Remove belt.

E9

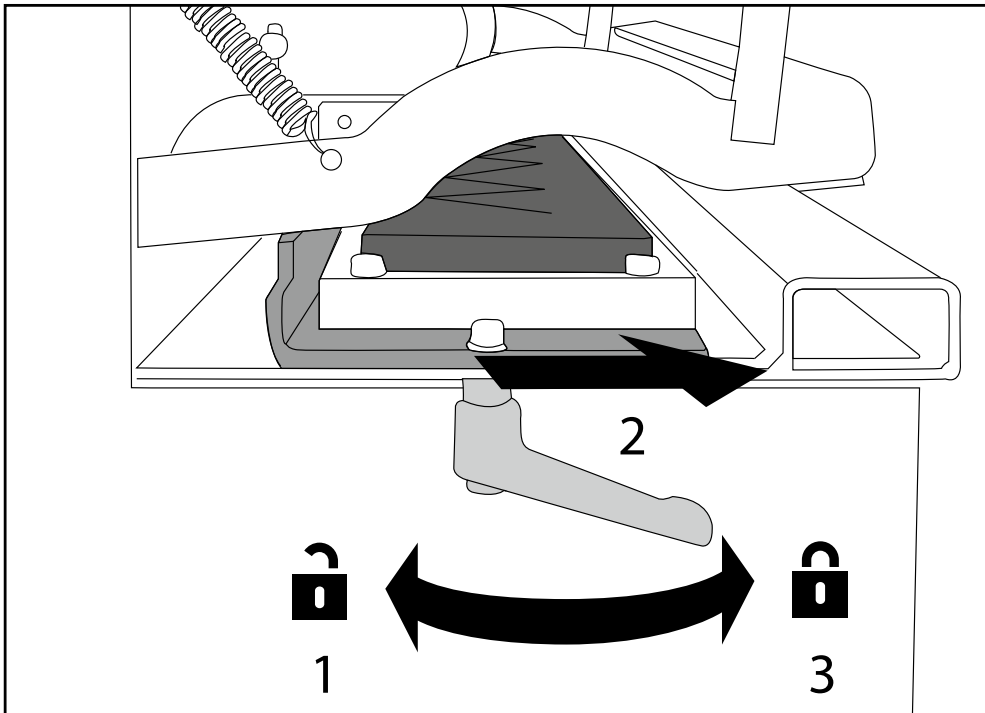

1. Unlock punchboard tray at both ends. 2. Move punchboard tray to front most position. 3. Lock punchboard tray at both ends.

Attention: When required, reposition lock handle (B2).

Bias Finger Over Finger Punching

E10

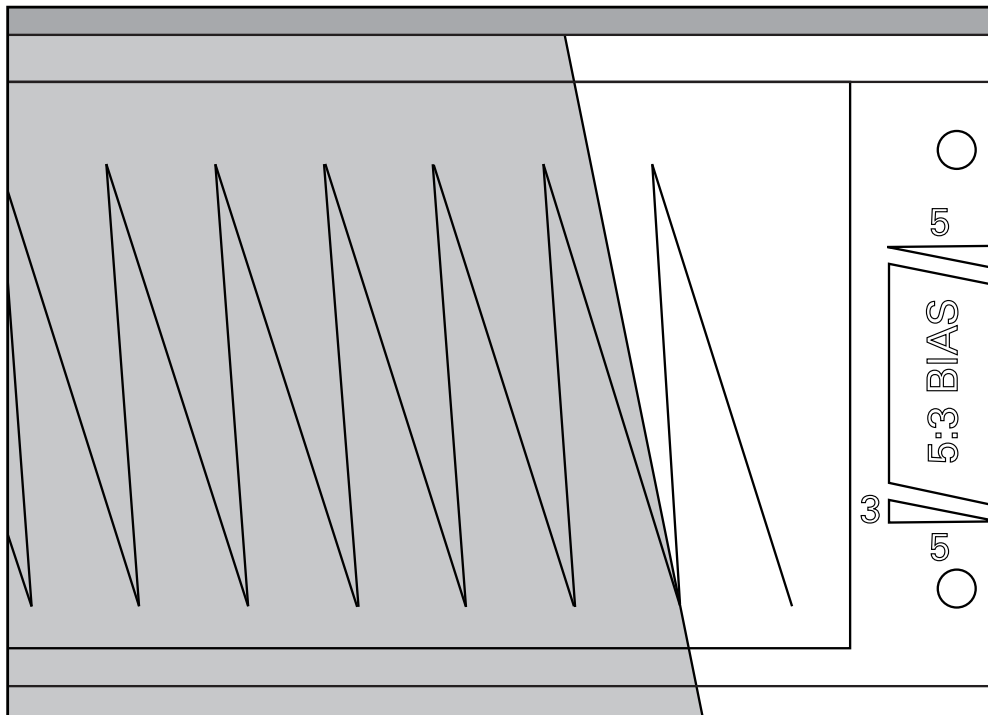

Insert opposite belt end cover side up and flush against belt stop. Align right belt edge with bottom of V pattern in knife set.

E11

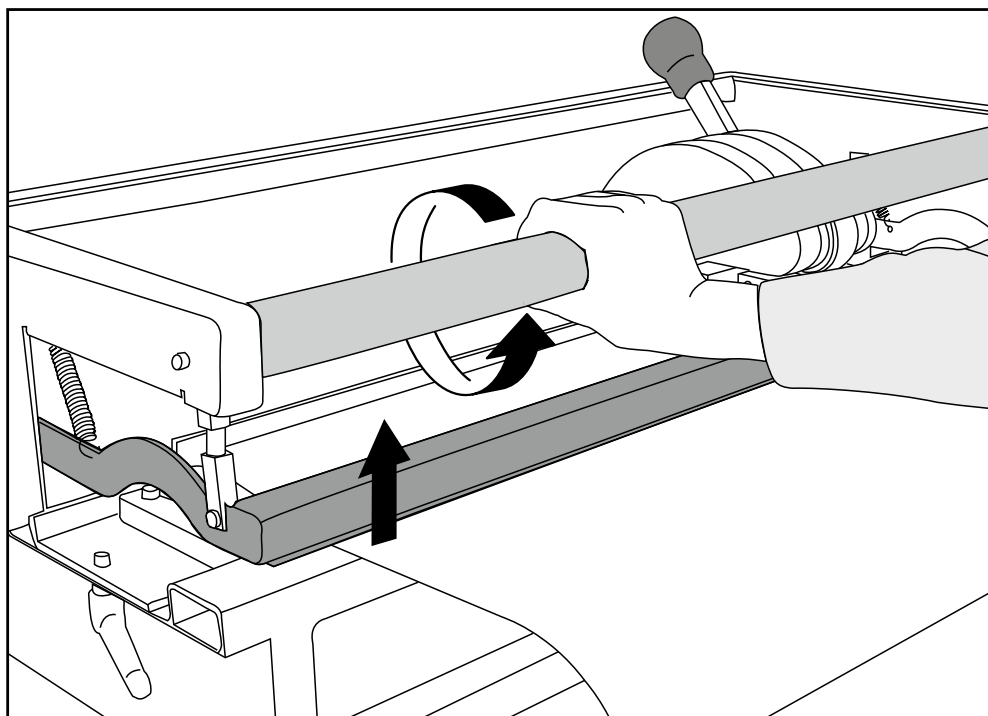

Turn belt clamp bar. Remove belt.

Bias Finger Over Finger Punching

E12

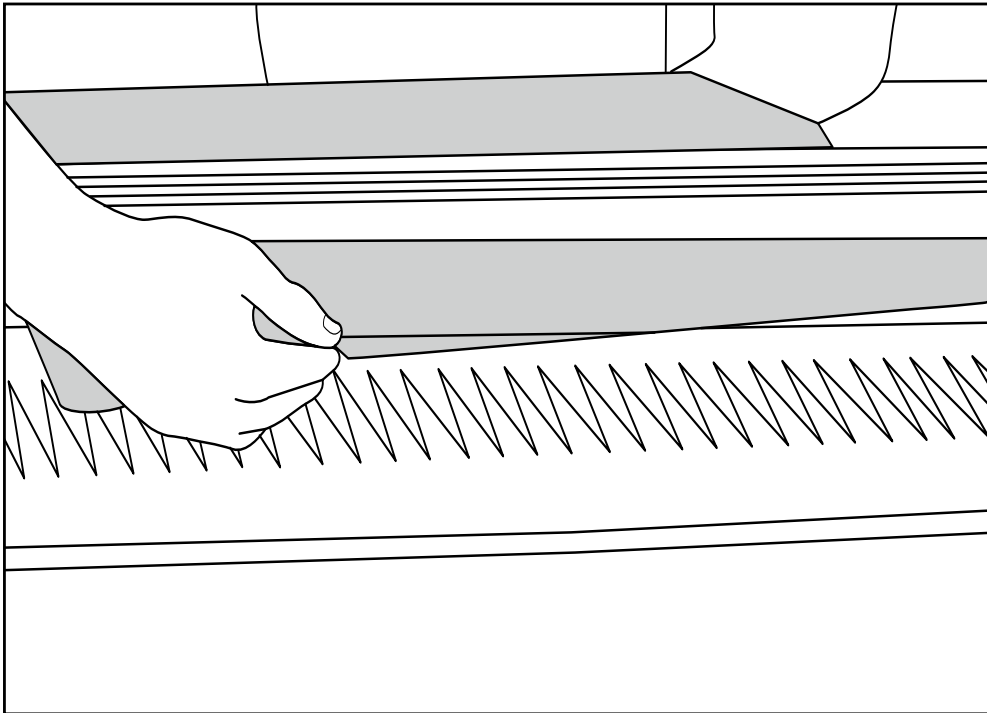

Lift top layer of belt up and then tuck the bottom layer under the punchboard tray.

E13

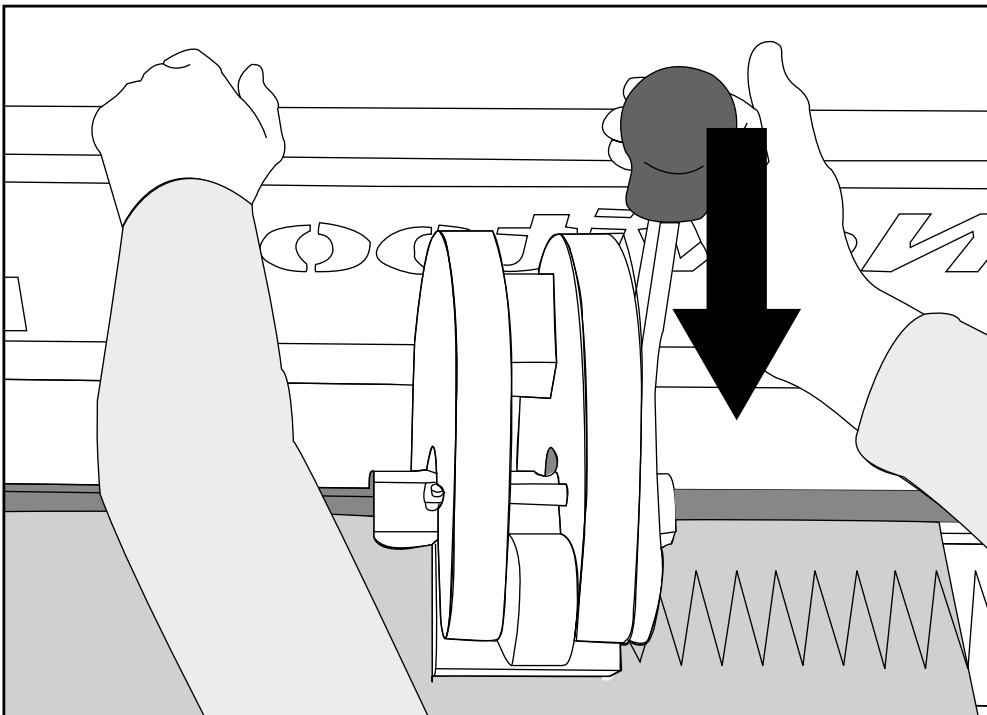

Once bottom layer is out of the way, lay top layer down and punch belt. Place left hand on rear frame for support. Use other hand to operate lever to punch belt. Punch in center, at both ends, and then across remainder of material. Remove excess punched material.

Bias Finger Over Finger Punching

E14

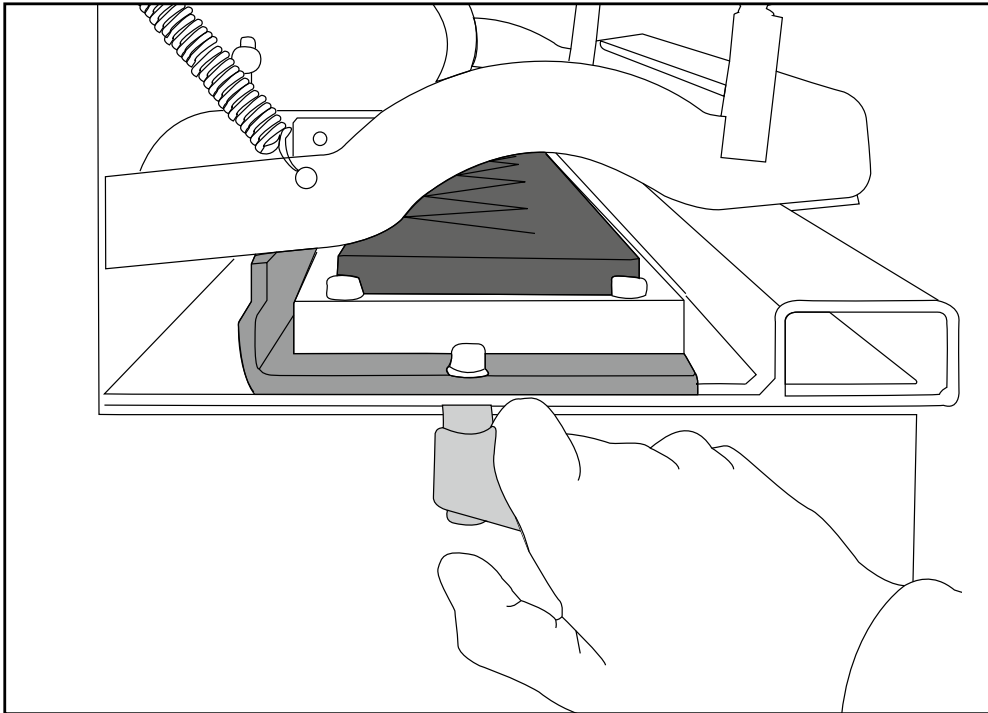

Keep belt clamped. 1. Unlock punchboard tray at both ends. 2. Slide it to final back position. 3. Lock punchboard tray at both ends (=1.38"/35mm displacement).

E15

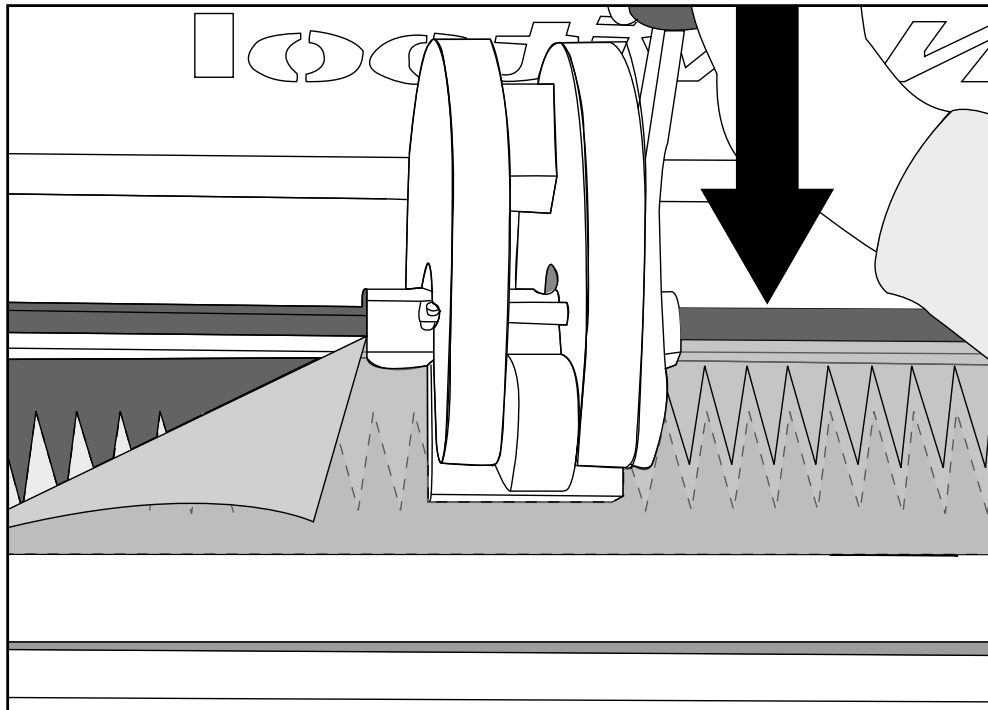

Lift top layer up of belt up and reposition bottom layer over punchboard. In this step you will only punch the bottom layer. Punch in center, at both ends, and then across remainder of material. Remove excess punched material.

Bias Finger Over Finger Punching

E16

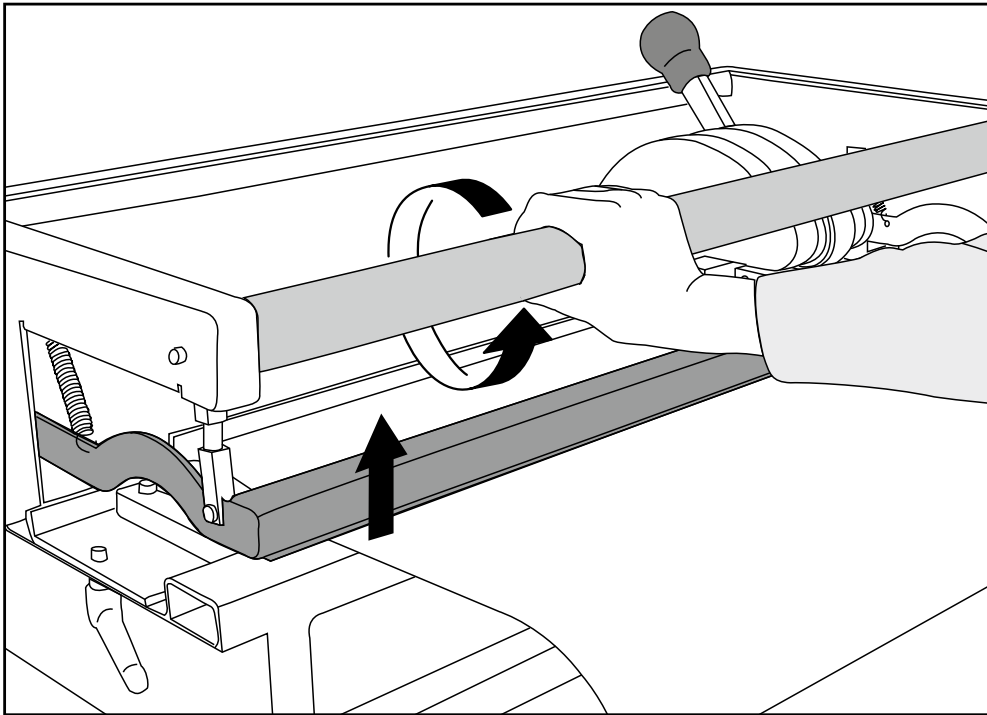

Turn belt clamp bar. Remove belt.

Replacement Parts

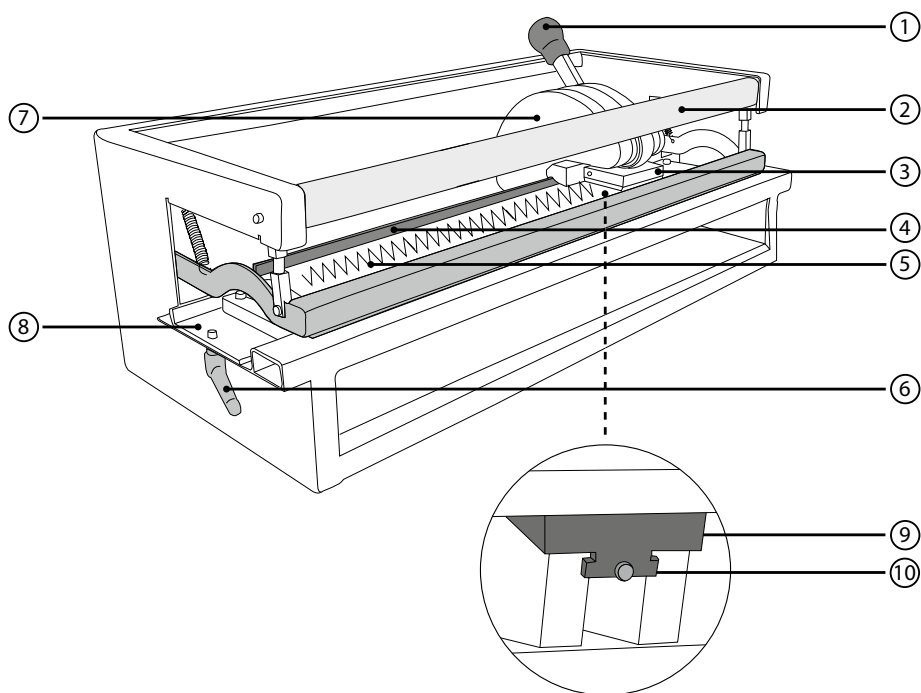

Replacement Parts

POSITION	DESCRIPTION	ORDERING NUMBER	ITEM CODE	POSITION	DESCRIPTION	ORDERING NUMBER	ITEM CODE
1	C-frame Handle Grip	PUN-M-CFRAMEHNDLGRIP	08197	6	Lock Handle for Punchboard Tray	PUN-M-TABLELEVER	08191
2	Belt Clamp Bar for PunM 300	PUN-M-ACTUATORBAR-300	08182	8	Punchboard Support Table for PunM 300	PUN-M-TABLE-300	08188
	Belt Clamp Bar for PunM 600	PUN-M-ACTUATORBAR-600	08183		Punchboard Support Table for PunM 600	PUN-M-TABLE-600	08189
	Belt Clamp Bar for PunM 900	PUN-M-ACTUATORBAR-900	08184		Punchboard Support Table for PunM 900	PUN-M-TABLE-900	08190
3	Complete Punchblock	PUN-M-PUNCH-PLATE	08128	10	C-frame Wedge	PUN-M-ADJUSTERWEDGE	08194
Component of 3	Replacement Nylon Punchpad and Tape	PUN-M-NYLONPAD	08279		Wedge Hardware Kit (plastic cap, locking collar, adjusting bar)	PUN-M-ADJUSTINGWEDGE-HARDWARE	08713
5	Torsion Bushing	FGTBSG	56521				

PUN M™ Manual Punch

ORDERING NUMBER	ITEM CODE	ORDERING NUMBER	ITEM CODE	ORDERING NUMBER	ITEM CODE
PUN M*		PUN M 600 PUNCHBOARDS		PUN M 900 PUNCHBOARDS	
PUN-M-300	08016	PUN-B-50×20-600	08020	PUN-B-50×20-900	08021
PUN-M-600	08017	PUN-B-70×15-600	08023	PUN-B-70×15-900	08024
PUN-M-900	08018	PUN-B-80×20-600	08026	PUN-B-80×20-900	08027
PUN M 300 PUNCHBOARDS		PUN-B-50×18×31BIAS-600	08540	PUN-B-50×18×31BIAS-900	08526
PUN-B-50×20-300	08019	PUN-B-80×20×113BIAS-600	08439	PUN-B-80×20×113BIAS-900	08440
PUN-B-70×15-300	08022			REPLACEMENT PARTS	
PUN-B-80×20-300	08025			PUN-M-NYLONPAD-KIT	08279
PUN-B-50X18X31BIAS-300	08539				

*Punchboards not included with Pun M; purchase separately.

Note: Custom punchboards are available for other finger dimensions. Contact Customer Service for information.

Transportation Security

F1

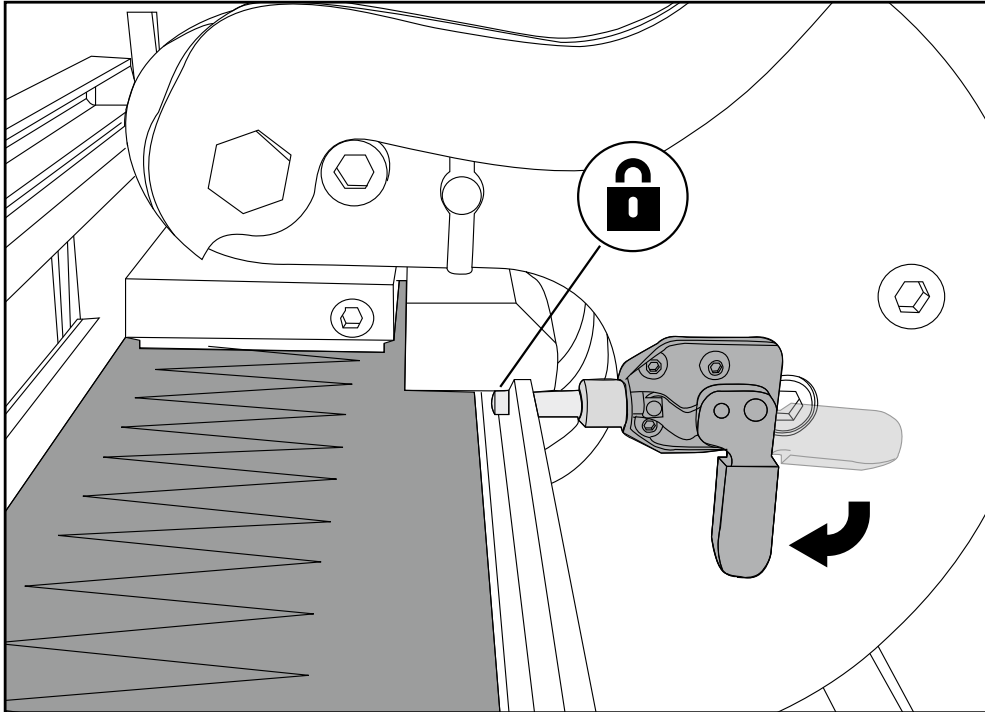

Position C-frame to middle of punchboard tray and slide locking pin into hole.

New Door No. 51 • Anna Salai, Nagalkeni • Pammal Village • Chennai - 600 044 • Tamil Nadu • India
Tel: +91-44-4856-6762 • E-mail: info.india@flexco.com

Visit www.flexco.com for other Flexco locations and products.

©2021 Flexible Steel Lacing Company. 09-13-22. For reorder: X6475

