

T-TYPE™ Secondary Belt Cleaner

Efficient, Compact, Robust

The Flexco T-Type™ Secondary Belt Cleaner is compact and designed to be positioned just off the head pulley to remove persistent carryback from the belt. Stand alone, or when used in conjunction with a pre-cleaner, the T-Type™ cleaner is a reliable choice for maintaining a highly efficient cleaning system. The pivoting carbide blades can rotate $\pm 15^\circ$ and adapt perfectly to the belt surface.

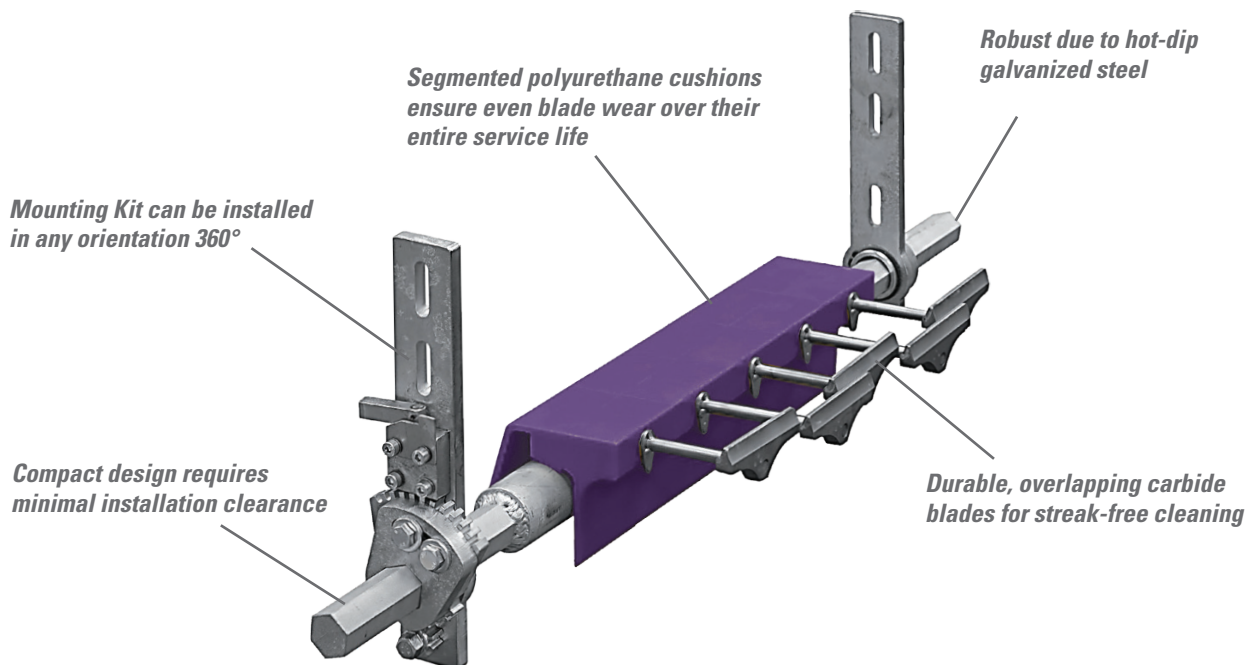

Features and Benefits

- **Cleaning Performance.** The combination of thin and overlapping tungsten carbide blades with the robust tensioner system provides excellent cleaning performance.
- **Operation Area.** Thanks to its individual polyurethane segments, every single carbide blade of the T-Type™ adapts perfectly to the belt surface and removes even the most stubborn material.
- **Installation Space/Clearance.** Due to its compact design, the T-Type™ requires minimal installation space (clearance) and fits almost all conveyor structures.
- **Maintenance.** Extremely quick and easy maintenance is possible thanks to its plug-in cushions and torsion tensioner system.

T-TYPE™ Secondary Belt Cleaner

Specifications and Guidelines

Maximum Belt Speed

4 m/s (800 FPM)

Temperature Rating

-30 to 82°C (-20 to 180°F)

Usable Blade Wear Length

10 mm (3/8")

Blade Material

Tungsten Carbide
(for vulcanized belts only)

Available for Belt Widths

400 to 1600 mm (16 to 64")

Clearance Required

Mounting Kit can be installed
in any orientation 360°

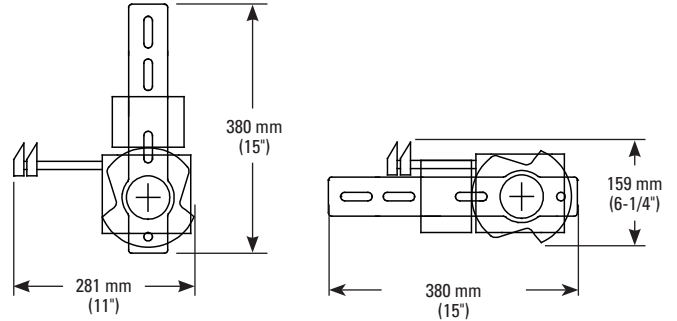

Cleaner Size		Pole Length		Max Conveyor Span	
mm	in.	mm	in.	mm	in.
400	16	1140	44	960	38
600	24	1340	52	1160	46
800	32	1540	60	1360	54
1000	40	1740	68	1560	62
1200	48	1940	76	1760	70
1400	56	2090	82	1910	76
1600	64	2290	90	2110	84

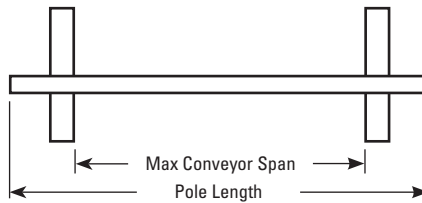

Ordering Information

T-Type™ Secondary			
Belt Width		Ordering Number	Item Code
mm	in.		
400	16	TV400	93505
600	24	TV600	93506
800	32	TV800	93507
1000	40	TV1000	93508
1200	48	TV1200	93509
1400	56	TV1400	93510
1600	64	TV1600	93511

Replacement Blades	
Ordering Number	Item Code
TSAS (short)	93512
TSAL (long)	93513

Number of Blades per Belt Width							
mm	400	600	800	1000	1200	1400	1600
in.	16	24	32	40	48	56	64
TSAS	2	3	4	5	6	7	8
TSAL	1	2	3	4	5	6	7

Visit www.flexco.com for other Flexco locations and products, or to find an authorised distributor.

©2021 Flexible Steel Lacing Company. 02-25-25. X6409

