

T-TYPE™ Secondary Belt Cleaner

Efficient, Compact, Robust

The Flexco T-Type™ Secondary Belt Cleaner is compact and designed to be positioned just off the head pulley to remove persistent carryback from the belt. Stand alone, or when used in conjunction with a pre-cleaner, the T-Type cleaner is a reliable choice for maintaining a highly efficient cleaning system. The pivoting carbide blades can rotate $\pm 15^\circ$ and adapt perfectly to the belt surface.

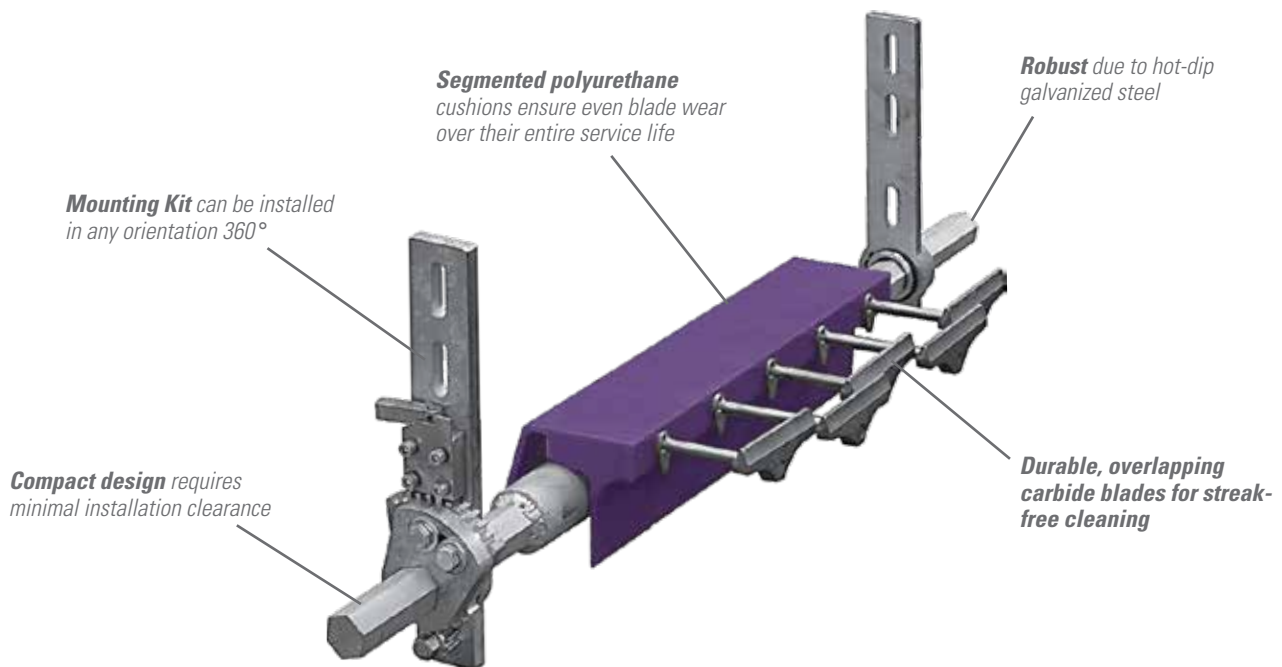

Features and Benefits

- **Cleaning Performance.** The combination of thin and overlapping tungsten carbide blades with the robust tensioner system provides excellent cleaning performance.
- **Operation Area.** Thanks to its individual polyurethane segments, every single carbide blade of the T-Type adapts perfectly to the belt surface and removes even the most stubborn material.
- **Installation Space/Clearance.** Due to its compact design, the T-Type requires minimal installation space (clearance) and fits almost all conveyor structures.
- **Maintenance.** Extremely quick and easy maintenance is possible thanks to its plug-in cushions and torsion tensioner system.

T-TYPE™ Secondary Belt Cleaner

Specifications and Guidelines

Maximum Belt Speed

4 m/s

Temperature Rating

-30°C to 82°C

Usable Blade

Wear Length

10 mm

Blade Material

Tungsten carbide (for vulcanized belts only)

Available for Belt Widths

400 mm to 1600 mm

Cleaner Size	Pole Length	Max Conveyor Span
400	1140	960
600	1340	1160
800	1540	1360
1000	1740	1560
1200	1940	1760
1400	2090	1910
1600	2290	2110

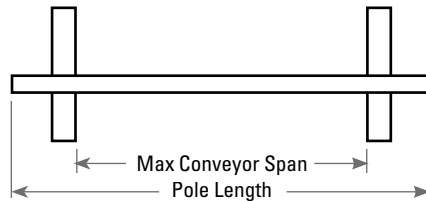

Clearance Required

Mounting Kit can be installed in any orientation 360°

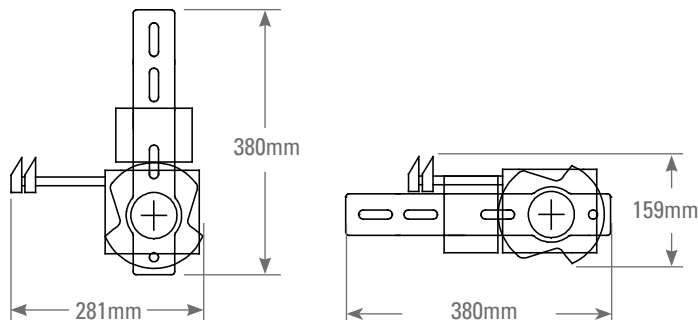

Ordering Information

T-Type™ Secondary Belt Cleaner		
Belt Width	Ordering Number	Item Code
400	TV400	93505
600	TV600	93506
800	TV800	93507
1000	TV1000	93508
1200	TV1200	93509
1400	TV1400	93510
1600	TV1600	93511

Replacement Blades	
Ordering Number	Item Code
TSAS (short)	93512
TSAL (long)	93513

Number of Blades per Belt Width							
mm	400	600	800	1000	1200	1400	1600
TSAS	2	3	4	5	6	7	8
TSAL	1	2	3	4	5	6	7

Authorized Distributor:

Flexco Europe GmbH • Maybachstrasse 9 • 72348 Rosenfeld • Deutschland
Tel: +49-7428-9406-0 • Fax: +49-7428-9406-260 • E-mail: europe@flexco.com

Visit www.flexco.com for other Flexco locations and products.

©2021 Flexible Steel Lacing Company. 03/08/21. For reorder: X6409

