

FLEXCO

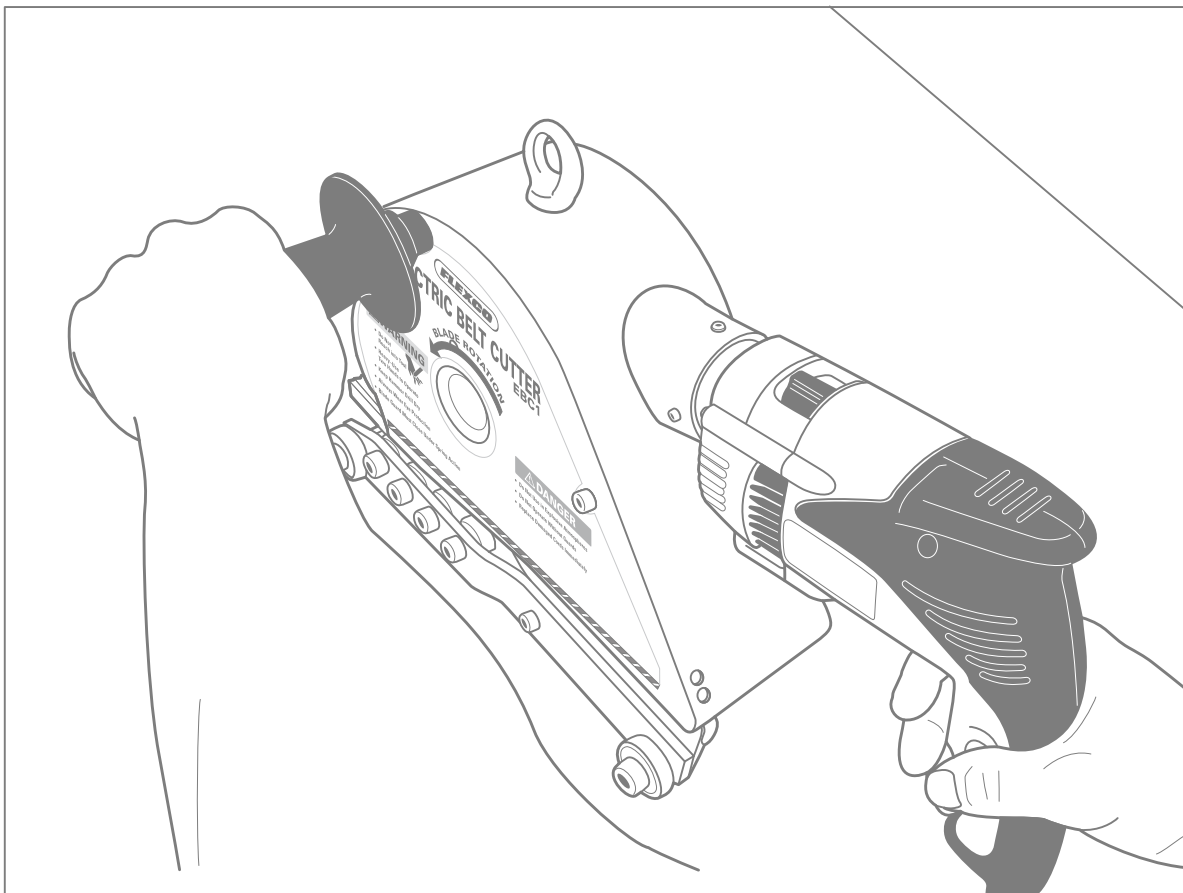

Electric Belt Cutter Safety and Operating Manual for Corded and Cordless Models

For cutting rubber and elastomeric materials only.



WARNING

IMPROPER OR UNSAFE use of this power tool can result in death or serious bodily injury! This manual contains important information about product function and safety. Please read and understand this manual BEFORE operating the power tool. Please keep this manual available for other users and owners before they use the power tool. This manual should be stored in a safe place.

Table of Contents

Main Components.....	3
Tool Specifications.....	3
General Safety Rules.....	4-7
Tool Preparation	8
Operation of Electric Hammer Drill	8
Electric Cutter Operation.....	9
Tool Maintenance–Bearings	9
Tool Maintenance–Blade Replacement	10
Logbook.....	11
Spare Parts.....	12

Electric Belt Cutter

Main Components *(corded model shown)*

1. Housing
2. Blade Guard and Cutting Guide
3. Carriage
4. Eye Bolt
5. Handle
6. Electric Hammer Drill
7. Circular Blade
8. Power Cord
9. Rear Carriage Bolt
10. Carriage Support Bolt

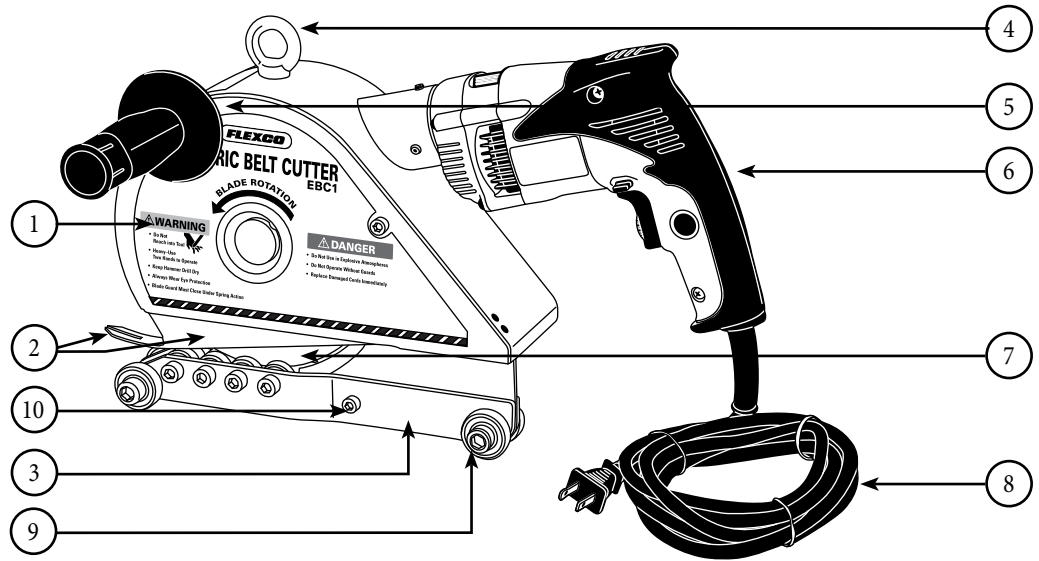

DO NOT carry tool by electric hammer drill handle. It is recommended that you place tool in carrying case for traveling extended distances.

Tool Specifications

Specifications	ITEC-170		ITEC-170C		ITEC-220		ITEC-220C	
	Metric	Imperial	Metric	Imperial	Metric	Imperial	Metric	Imperial
Tool Description								
Weight	13.6 kg	30 lbs	13.6 kg	30 lbs	18.1 kg	40 lbs	18.1 kg	40 lbs
Machine Housing	Stainless Steel							
Blade Material	High Speed Steel							
Blade Size	ø 170 x 4, hole ø 20, key way 6 (mm)	ø 6.70 x .157, hole ø .787, key way .236 (in)	ø 170 x 4, hole ø 20, key way 6 (mm)	ø 6.70 x .157, hole ø .787, key way .236 (in)	ø 220 x 6, hole ø 25, key way 8 (mm)	ø 8.66 x .236, hole ø .984, key way .315 (in)	ø 220 x 6, hole ø 25, key way 8 (mm)	ø 8.66 x .236, hole ø .984, key way .315 (in)
Drill Description								
Drill – Make and Model	HiKOKI DV16V WUZ	Metabo HPT DV16V	Makita DDF458	Makita XPH03MB	Metabo SBE 850-2	Metabo SBE 850-2	Makita DDF458	Makita XFD03M
Power Source / Charger Source	EBC1, CEBC1, EBC2, and CEBC2 use 120V. EBC1-220, CEBC1-220, EBC2-220, AND CEBC2-220 USE 230V							
Battery - Amp Hour	N/A		5.0AH	4.0AH	N/A		5.0AH	5.0AH
Cutting Capacity								
Cutting Capacity – Rubber Belt	Up to 25 mm	Up to 1 inch	Up to 25 mm	Up to 1 inch	Up to 50 mm	Up to 2 inch	Up to 50 mm	Up to 2 inch
Cutting Capacity – PVC Belt	Up to 630 kN/m	Up to 360 PIW	Up to 630 kN/m	Up to 360 PIW	Up to 2000 kN/m	Up to 1140 PIW	Up to 2000 kN/m	Up to 1140 PIW
Material Hardness	25° - 90° Shore A							



General Safety Rules

—Save These Instructions—

Signal words:

“DANGER” indicates an imminently hazardous situation which, if not avoided, will result in death or serious injury. The signal word is limited to the most extreme situations.

“WARNING” indicates a potentially hazardous situation which, if not avoided, could result in death or serious injury.

“CAUTION” indicates a potentially hazardous situation which, if not avoided, may result in minor or moderate injury. It may also be used to alert against unsafe practices.

Safety Symbol



This international safety symbol is used to identify and call attention to specific safety matters.

Safety Information

To Avoid Severe Personal Injury or Property Damage, read carefully and understand the following Safety Precautions.

1. WORK AREA

! CAUTION

Keep your work area clean and well lit. Cluttered benches and dark areas invite accidents.

! DANGER

Do not operate power tools in explosive atmospheres, such as in the presence of flammable liquids, gases, or dust. Power tools create sparks which may ignite the dust or fumes.

! CAUTION

Keep bystanders, children, and visitors away while operating a power tool. Distractions can cause you to lose control.

! WARNING

Never leave tool until it comes to a complete stop.

! CAUTION

Operation of gear units is permitted at ambient temperatures between -20°C and $+40^{\circ}\text{C}$ (-4°F and $+104^{\circ}\text{F}$). However, for temperatures between -20°C and -10°C (-4°F and $+14^{\circ}\text{F}$) unit may only start up after it has been progressively and evenly pre-heated, or otherwise initially operated unloaded. Load may then be connected to the output shaft when the gear unit has reached the temperature of -10°C (14°F) or higher.

2. ELECTRICAL SAFETY

! DANGER

Double Insulated tools are equipped with a polarized plug (one blade is wider than the other). This plug will fit in a polarized outlet only one way. If the plug does not fit fully in the outlet, reverse the plug. If it still does not fit, contact a qualified electrician to install a polarized outlet. Do not change the plug in any way. Double Insulation eliminates the need for the three wire grounded power cord and grounded power supply system.

General Safety Rules

⚠️ WARNING

Avoid body contact with grounded surfaces such as pipes, radiators, ranges, and refrigerators. There is an increased risk of electric shock.

⚠️ WARNING

Do not expose power tools to rain or wet conditions. Water entering a power tool will increase the risk of electric shock.

⚠️ DANGER

Do not abuse cords. Never use cords to carry the tool or pull the plug from a receptacle. Keep cord away from heat, oil, sharp edges, or moving parts. Replace damaged cords immediately. Damaged cords increase the risk of electric shock.

⚠️ WARNING

When operating a power tool outdoors, use an outdoor extension cord marked “W-A” or “W”. These cords are rated for outdoor use and reduce the risk of electric shock.

⚠️ CAUTION

ITEC-170C/ITEC-220C Battery Tool Use and Care

Ensure the switch is in the off position before inserting battery pack. Inserting the battery pack into power tools that have the switch on invites accidents.

Recharge only with the charger specified by the manufacturer. A charger that is suitable for one type of battery pack may create a risk of fire when used with another battery pack.

Use power tools only with specifically designated battery packs. Use of any other battery packs may create a risk of injury and fire. When battery pack is not in use, keep it away from other metal objects like paper clips, coins, keys, nails, screws, or other small metal objects that can make a connection from one terminal to another. Shorting the battery terminals together may cause burns or a fire.

Under abusive conditions, liquid may be ejected from the battery, avoid contact. If contact accidentally occurs, flush with water. If liquid contacts eyes, additionally seek medical help. Liquid ejected from the battery may cause irritation or burns.

3. PERSONAL SAFETY

⚠️ WARNING

Stay alert, watch what you are doing and use common sense when operating a power tool. Do not use tool while tired or under the influence of drugs, alcohol, or medication. A moment of inattention while operating power tools may result in serious personal injury.

⚠️ WARNING

Dress properly. Do not wear loose clothing or jewelry. Contain long hair. Keep your hair, clothing, and gloves away from moving parts. Loose clothes, jewelry, or long hair can be caught in moving parts.

⚠️ WARNING

Avoid accidental starting. Be sure switch is off before plugging in or before battery is inserted. Carrying tools with your finger on the switch or plugging in tools that have the switch on invites accidents.

⚠️ WARNING

Do not overreach. Keep proper footing and balance at all times. Proper footing and balance enables better control of the tool in unexpected situations.

⚠️ CAUTION

Use safety equipment. Always wear eye protection. Dust mask, non-skid safety shoes, hard hat, or hearing protection must be used for appropriate conditions.

General Safety Rules

⚠ WARNING

Never alter or remove safety devices.

⚠ WARNING

Keep your hands and fingers away from all moving parts, e.g. the blade, at all times.

4. TOOL USE AND CARE

⚠ WARNING

Always use belt cutter on a level, firm surface. Cutting is only allowed when operating the machine with one hand on the handle and the other on the drill. Before starting the machine, the handle must be installed on either the right or left side.

⚠ CAUTION

Do not force tool.

⚠ WARNING

Do not use tool if switch does not turn it on or off. Any tool that cannot be controlled with the switch is dangerous and must be repaired.

⚠ WARNING

Disconnect the plug from the power source or remove battery before making any adjustments, changing accessories, or storing the tool. Such preventive safety measures reduce the risk of starting the tool accidentally.

⚠ WARNING

Store idle tools out of reach of children and other untrained persons. Tools are dangerous in the hands of untrained users.

⚠ CAUTION

Maintain tools with care. Keep cutting tools sharp and clean. Properly maintained tools, with sharp cutting edges are less likely to bind and are easier to control.

⚠ CAUTION

Check for misalignment or binding of moving parts, breakage of parts, and any other condition that may affect the tool's operation. If damaged, have the tool serviced before using. Many accidents are caused by poorly maintained tools.

5. SERVICE AND MAINTENANCE

⚠ WARNING

Tool service must be performed only by qualified repair personnel. Service or maintenance performed by unqualified personnel could result in a risk of injury.

⚠ CAUTION

When servicing a tool, use only identical replacement parts. Use of unauthorized parts or failure to follow Maintenance Instruction may create a risk of electric shock or injury.

⚠ DANGER

Do not use power tools if the plastic housing or handle is cracked. Cracks in the tool's housing or handle can lead to electric shock. Such tools should not be used until repaired.

⚠ CAUTION

Do not wipe plastic parts with solvent. Solvents such as gasoline, thinner, benzene, carbon tetrachloride, and alcohol may damage and crack plastic parts. Do not wipe them with such solvents. Wipe plastic parts with a soft cloth lightly dampened with soapy water and dry thoroughly.

General Safety Rules

⚠️ WARNING

NEVER use a tool which is defective or operating abnormally. If the tool appears to be operating unusually, making strange noises, or otherwise appears defective, stop using it immediately and arrange for repairs.

⚠️ WARNING

Before performing any belt cutter maintenance, remove the plug from the socket or remove battery from tool and follow all procedures noted in manual.

6. CIRCULAR CUTTER SAFETY

⚠️ WARNING

Make sure that any power cable is not located between circular blade and lower carriage.

⚠️ WARNING

Keep your body positioned to either side of the cutter blade, but not in line with the cutter blade.

⚠️ WARNING

Check blade guard for proper closing before each use. Do not operate cutter if blade guard does not move freely and close instantly. Never clamp or tie blade guard into the open position.

⚠️ WARNING

Never hold piece being cut in your hands or across your leg. It is important to support the work properly to minimize body exposure, blade binding, or loss of control.

⚠️ DANGER

Hold tool by the insulated gripping surfaces when performing an operation where the cutting tool may contact hidden wiring. Contact with a “live” wire will also make exposed metal parts of the tool “live” and shock the operator.

⚠️ WARNING

Do not run the cutter while carrying it. Lower guard may be opened by contact with your clothing. Accidental contact with the spinning cutter blade could result in serious personal injury.

⚠️ CAUTION

Do not use dull or damaged blade.

7. REPLACING THE CIRCULAR BLADE

⚠️ CAUTION

Do not attempt to sharpen blades. This will affect cutting completely through belt.

⚠️ WARNING

Always wear cut-proof safety gloves and safety glasses when replacing blade. Blade is razor sharp, treat it accordingly.

⚠️ WARNING

Before performing a blade replacement, remove the plug from the socket or remove battery from tool and follow all procedures noted in manual.

⚠️ WARNING

Only authorized and trained technicians should work on the cutter.

⚠️ WARNING

Test the cutter after blade replacement to make sure that it can be used safely.

Electric Belt Cutter

Tool Preparation

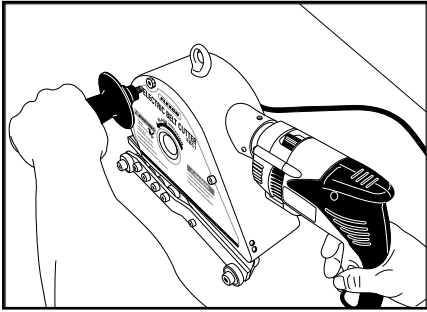

Fig. 1. Right-Handed Operation

Mounting of side handle:

The Flexco Electric Belt Cutter is supplied with a handle that can be mounted on either side of the tool: For right-handed operation, thread the handle into the left side of the tool housing, see Fig. 1. For left-handed operation, thread the handle into the right side of the housing, see Fig. 2.

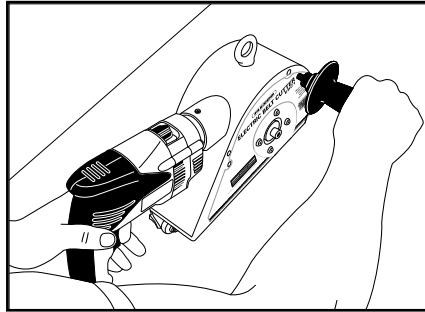

Fig. 2. Left-Handed Operation

Eye bolt use with optional balancer:

The Flexco Electric Belt Cutters are supplied with an eye bolt for mounting the cutters to tool balancers. **NOTE:** Tool balancer must be purchased separately. Be sure to use a balancer that is properly rated for the weight of the belt cutter and has a cable long enough to permit safe operation of the cutter. The ITEC-170C and ITEC-170 weigh 13.6 kg (30 lbs.) and the ITEC-220C and ITE220 weigh 18.1 kg (40 lbs.).

Operation of Electric Hammer Drill (corded model shown)

EBC1

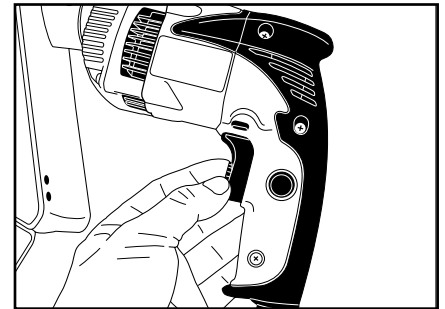
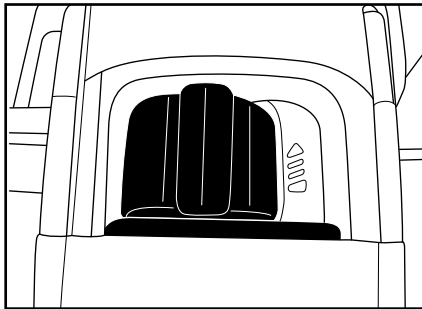
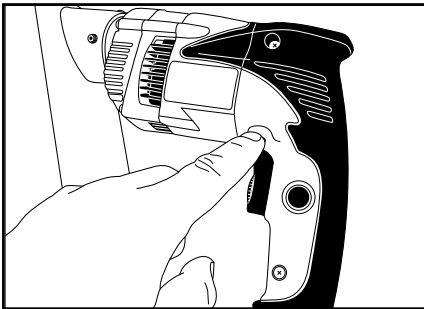

EBC2

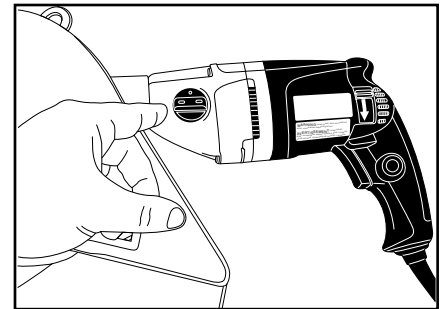
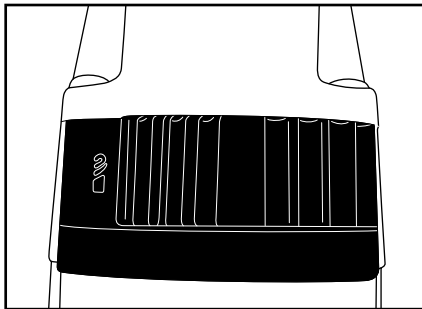
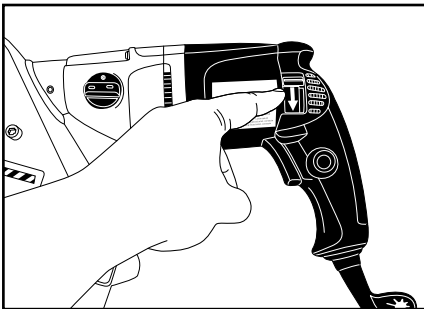

For normal use, operate in Reverse Direction; press drilling direction button for reverse direction operation.

Operate in Drill Mode only; slide the action mode selector switch to indicate drill mode.

Cutting Speed Adjustment; adjust Electric Hammer Drill to low speed by turning switch to low speed. For best results, always operate cutters in low speed.

Electric Belt Cutter

Electric Cutter Operation

For best results: Always elevate belt. • Always use appropriate lubricant. • Always cut in low speed.

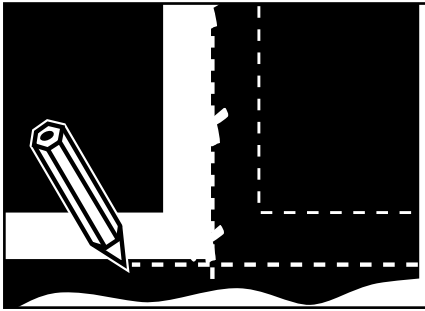

Square belt using centerline method

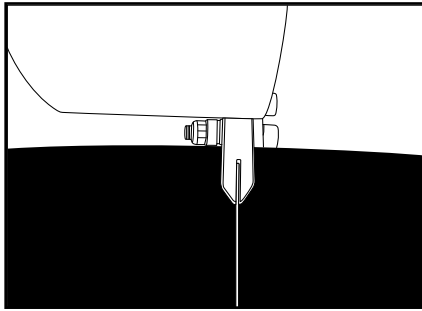

Use of Cutting Guide

Make sure belt is clean. Spray area to be cut with silicone lubricant (Flexco # 30932, not included). Lift Blade Guard and insert belt between Carriage and Blade Guard. Position Electric Belt Cutter so that slot in Cutting Guide is directly centered above cut line on belt.

Producing Square Edge during cutting

In order to produce a square edge during cutting, hold Electric Belt Cutter perpendicular to belt throughout the entire cutting operation. Use two hands for operation.

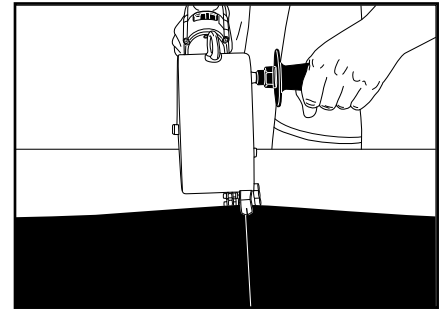

Belt Cutting

Position Electric Belt Cutter on edge of belt at square line. Align Cutting Guide on the Blade Guard with square line on belt. Squeeze drill trigger to start drill.

Tool Maintenance—Bearings

Unplug drill from power source prior to performing any maintenance.

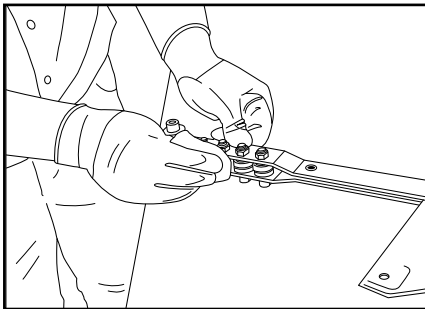

Clean Belt Support Bearings when dirty. Wipe Bearings with a clean cloth and a solvent such as mineral spirits.

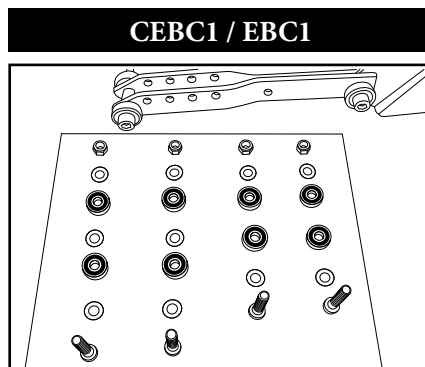

Support Bearings may be taken apart for a more thorough cleaning. Replace Bearings in the order shown above.

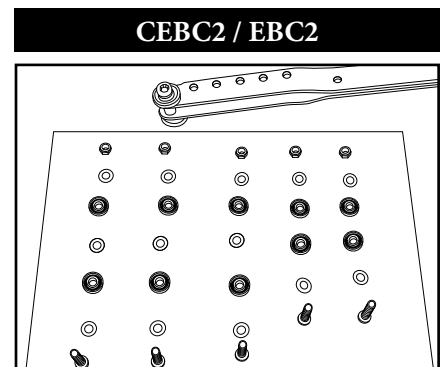

Electric Belt Cutter

Tool Maintenance–Blade Replacement *(corded model shown)*

If the Belt Cutter is difficult to operate, the blade may be worn and need replacement. Unplug drill from power source. Always wear cut-proof safety gloves and safety glasses when replacing blade.

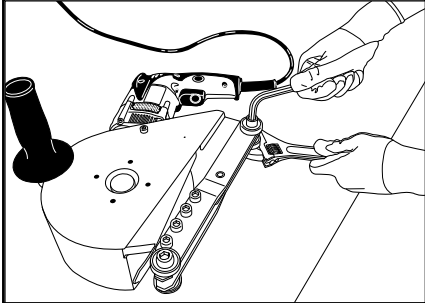

1. Loosen Rear Carriage Bolt.

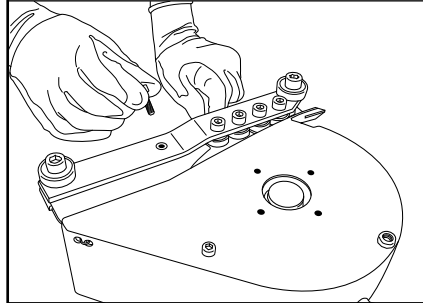

2. Remove Carriage Support Bolt and Nut.
WARNING: DO NOT TOUCH BLADE.

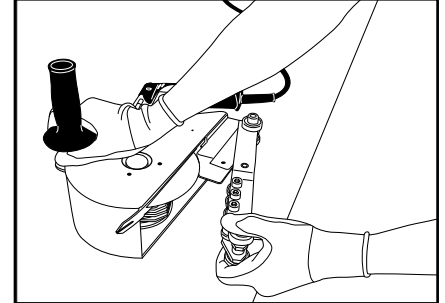

3. Rotate Carriage away from Blade.

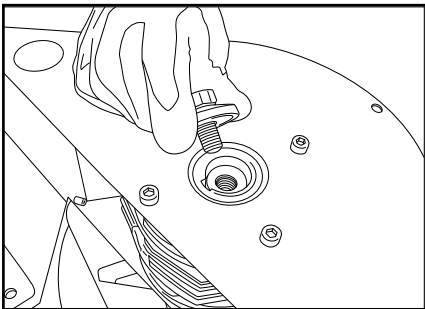

4. Remove Blade Mount Bolt.

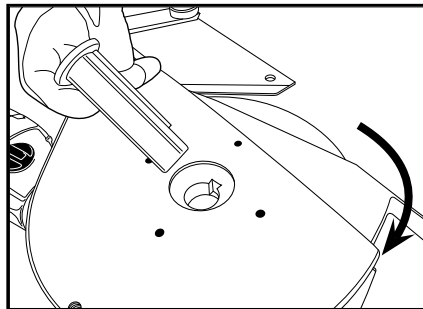

5. Remove Blade Mount Shaft.
WARNING: Blade edge is very sharp. DO NOT TOUCH EDGE OF BLADE!
Push the Blade Guard into the Cutter Housing just enough to clear the Blade. Remove the Blade and Blade Spacer carefully.

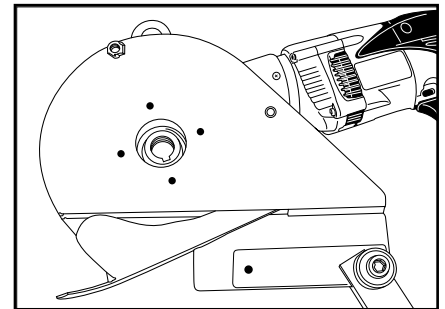

6. Carefully replace Blade Spacer and slide new Blade into Housing. Align keyway in Blade, Spacer, and Gearbox and insert Blade Mount Shaft. Secure Blade with Blade Mount Bolt.

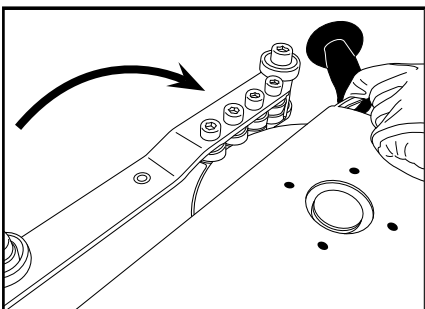

7. Carefully pivot Carriage back into place. Be careful to not damage Blade as it slides between the Belt Support Bearings.

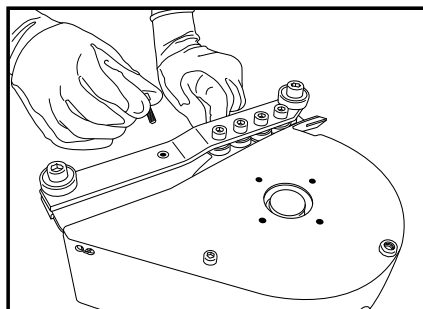

8. Replace Carriage Support Bolt. Tighten rear Carriage Bolt.

Electric Belt Cutter

Spare Parts *(corded model shown)*

1. Replacement Blade
2. Handle
3. Eye Bolt
4. Electric Hammer Drill

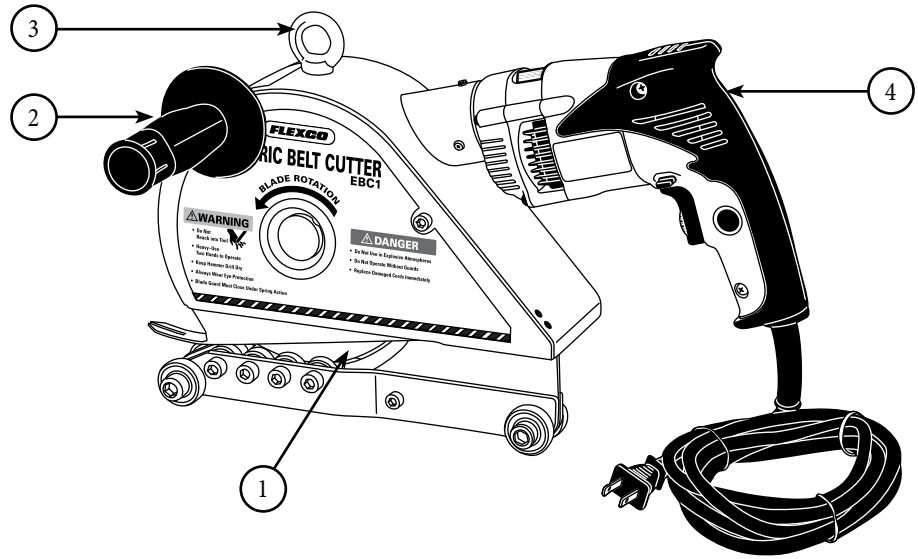

Spare Parts List		
Description	Ordering Number	Item Code
Replacement blade for ITEC-170	EBC1-B	30003
Replacement blade for ITEC-220	EBC2-B	30004
Replacement electric hammer drill for ITEC-170	EBC1-DR	30005
Replacement electric hammer drill for ITEC-220	EBC2-DR	30006
Replacement electric hammer drill for ITEC-170C	EBC1-220-DR	30013
Replacement electric hammer drill for ITEC-220C	EBC2-220-DR	30014
Replacement eye bolt for ITEC-170 & ITEC-220	EBC-EB	30007
Replacement handle for ITEC-170 & ITEC-220	EBC-H	30008

240 Macpherson Road • #02-01 • Singapore 348574
 Tel: +65-6484-1533 • Fax: +65-6484-1531 • E-mail: asiasales@flexco.com

Visit www.flexco.com for other Flexco locations and products.

©2017 Flexible Steel Lacing Company. 10-04-21. For reorder: X6339

