

STP Long Drop Bracket (Kit 56732)

Instructions for Installation

1. Reference Segmented Transfer Plate IOM (X4064 & 6041) for full installation details. This sheet is only to guide the installation of the optional mounting bracket. Kit 56732 contains two long mount brackets and installation hardware.

NOTE: Kit 56732 is intended for STP installations that require a longer backplate. Typical applications include power curves, horizontal to horizontal conveyors and horizontal to incline/decline where there is not sufficient conveyor structure to support the universal mount backplate. This kit does not include Item code GR538 stainless steel front plate. This item is included on your STP kit.

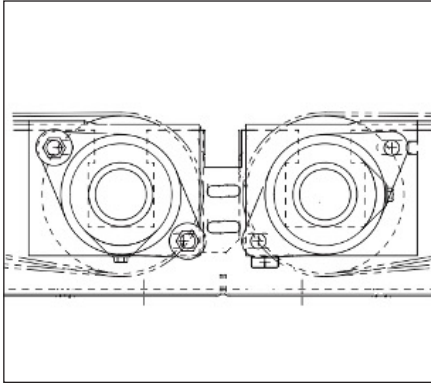

2. Position the bracket between the pulleys.

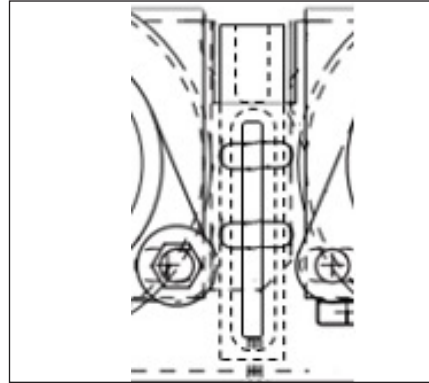

3. Insert the backplate between the pulleys and align the vertical slot with the horizontal conveyor slots.

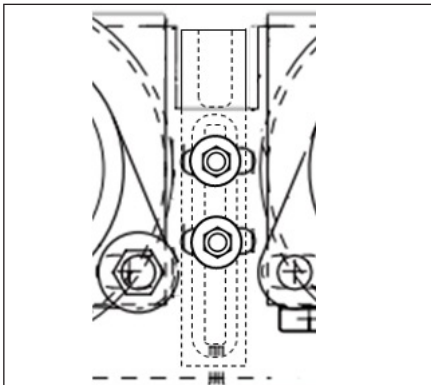

4. Secure the backplate using the provided hardware. The backplate can also be welded to the structure. Follow welding instruction mentioned on X4064

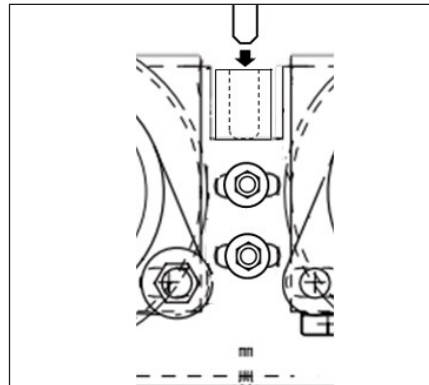

5. Install the transfer plate and follow steps 1 to 14 of IOM X4064. Once STP has been adjusted to proper height; tighten the fasteners until the washers are compressed and plus $\frac{1}{4}$ to $\frac{1}{2}$ a turn.

Visit www.flexco.com for other Flexco locations and products, or to find an authorized distributor.