

# Y-Type™ Heavy-Duty Secondary Belt Cleaner

---

## Installation, Operation and Maintenance Manual

---

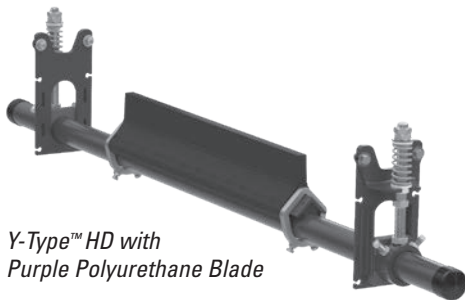

*Y-Type™ HD with  
Purple Polyurethane Blade*

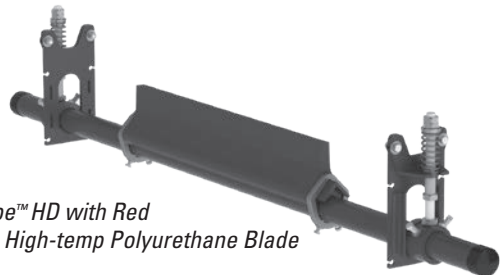

*Y-Type™ HD with Red  
Ultra High-temp Polyurethane Blade*

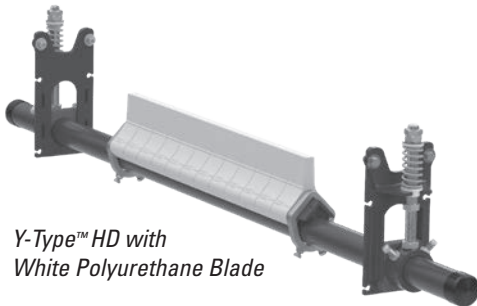

*Y-Type™ HD with  
White Polyurethane Blade*

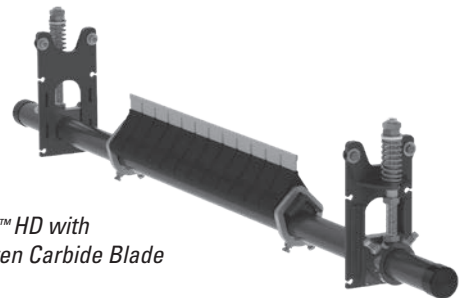

*Y-Type™ HD with  
Tungsten Carbide Blade*

# Y-Type™ Heavy-Duty Secondary Belt Cleaner

---

Serial Number: \_\_\_\_\_

Purchase Date: \_\_\_\_\_

Purchased From: \_\_\_\_\_

Installation Date: \_\_\_\_\_

Serial number information can be found on the Serial Number Label included in the Information Packet found in the cleaner carton.

This information will be helpful for any future inquiries or questions about belt cleaner replacement parts, specifications or troubleshooting.

# Table of Contents

---

<b>Section 1 – Important Information .....</b>	<b>2</b>
1.1 General Introduction .....	2
1.2 User Benefits .....	2
1.3 Service Option .....	2
<b>Section 2 – Safety Considerations and Precautions .....</b>	<b>3</b>
2.1 Stationary Conveyors .....	3
2.2 Operating Conveyors .....	3
<b>Section 3 – Pre-Installation Checks and Options.....</b>	<b>4</b>
3.1 Checklist .....	4
3.2 Optional Installation Accessories .....	4
<b>Section 4 – Y-Type™ Belt Cleaner Installation Instructions.....</b>	<b>5</b>
4.1 Installation Instructions - Pull-up Tensioning .....	5
4.2 Installation Instructions - Push-up Tensioning.....	8
<b>Section 5 – Pre-Operation Checklist and Testing.....</b>	<b>9</b>
5.1 Pre-Op Checklist .....	9
5.2 Test Run the Conveyor .....	9
<b>Section 6 – Maintenance .....</b>	<b>10</b>
6.1 New Installation Inspection .....	10
6.2 Routine Visual Inspection .....	10
6.3 Routine Physical Inspection.....	10
6.4 Blade Replacement Instructions.....	11
6.5 Maintenance Log .....	12
6.6 Cleaner Maintenance Checklist.....	13
<b>Section 7 – Troubleshooting .....</b>	<b>14</b>
<b>Section 8 – Specs and CAD Drawings.....</b>	<b>15</b>
8.1 Specs and Guidelines .....	15
8.2 CAD Drawing - Y-Type Heavy-Duty with Polyurethane Blades .....	16
8.3 CAD Drawing - Y-Type Heavy-Duty with Tungsten Carbide Blades .....	17
<b>Section 9 – Replacement Parts .....</b>	<b>18</b>
<b>Section 10 – Other Flexco Conveyor Products.....</b>	<b>21</b>

# Section 1 – Important Information

---

## 1.1 General Introduction

We at Flexco are very pleased that you have selected a Y-Type™ Heavy-Duty Secondary Belt Cleaner for your conveyor system.

This manual will help you to understand the operation of this product and assist you in making it work up to its maximum efficiency over its lifetime of service.

It is essential for safe and efficient operation that the information and guidelines presented be properly understood and implemented. This manual will provide safety precautions, installation instructions, maintenance procedures and troubleshooting tips.

If, however, you have any questions or problems that are not covered, please visit our web site or contact our Customer Service Department:

**Customer Service: 49-7428-9406-0**

**Visit [www.flexco.com](http://www.flexco.com) for other Flexco locations and products.**

Please read this manual thoroughly and pass it on to any others who will be directly responsible for installation, operation and maintenance of this cleaner. While we have tried to make the installation and service tasks as easy and simple as possible, **it does however require correct installation and regular inspections and adjustments to maintain top working condition.**

## 1.2 User Benefits

Correct installation and regular maintenance will provide the following benefits for your operation:

- Reduced conveyor downtime
- Reduced man-hour labor
- Lower maintenance budget costs
- Increased service life for the belt cleaner and other conveyor components

## 1.3 Service Option

The Y-Type™ Heavy-Duty Secondary Belt Cleaner is designed to be easily installed and serviced by your on-site personnel. However, if you would prefer complete turn-key factory service, please contact your local Flexco Field Representative.

## Section 2 – Safety Considerations and Precautions

---

Before installing and operating the Y-Type™ Heavy-Duty Secondary Belt Cleaner, it is important to review and understand the following safety information.

There are set-up, maintenance and operational activities involving both **stationary** and **operating** conveyors. Each case has a safety protocol.

---

### 2.1 Stationary Conveyors

The following activities are performed on stationary conveyors:

- Installation
- Blade replacement
- Repairs
- Tension adjustments
- Cleaning

#### **DANGER**

It is imperative that OSHA/MSHA Lockout/Tagout (LOTO) regulations, 29 CFR 1910.147, be followed before undertaking the preceding activities. Failure to use LOTO exposes workers to uncontrolled behavior of the belt cleaner caused by movement of the conveyor belt. Severe injury or death can result.

**Before working:**

- Lockout/Tagout the conveyor power source
- Disengage any takeups
- Clear the conveyor belt or clamp securely in place

#### **WARNING**

**Use Personal Protective Equipment (PPE):**

- Safety eyewear
- Hardhats
- Safety footwear

Close quarters, springs and heavy components create a worksite that compromises a worker's eyes, feet and skull.

PPE must be worn to control the foreseeable hazards associated with conveyor belt cleaners. Serious injuries can be avoided.

---

### 2.2 Operating Conveyors

There are two routine tasks that must be performed while the conveyor is running:

- Inspection of the cleaning performance
- Dynamic troubleshooting

#### **DANGER**

Every belt cleaner is an in-running nip hazard. Never touch or prod an operating cleaner. Cleaner hazards cause instantaneous amputation and entrapment.

#### **WARNING**

Belt cleaners can become projectile hazards. Stay as far from the cleaner as practical and use safety eyewear and headgear. Missiles can inflict serious injury.

#### **WARNING**

Never adjust anything on an operating cleaner. Unforseeable belt projections and tears can catch on cleaners and cause violent movements of the cleaner structure. Flailing hardware can cause serious injury or death.

## Section 3 – Pre-installation Checks and Options

---

### 3.1 Checklist

- Check that cleaner size is correct for beltline width
- Check belt cleaner carton and make sure all parts are included
- Review “Tools Needed” list on top of installation instructions
- Check the conveyor site:
  - Will cleaner be installed on a chute
  - Is the install on an open head pulley requiring mounting structure

### 3.2 Optional Installation Accessories

Pole extenders are available for wide, non-standard conveyor structures.

**76024**

#### HD Pole Extender Kit

- Provides 750mm (30") of extended pole length
- Includes 2 pole extenders

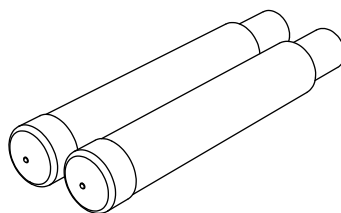

**79850**

#### YST HD Drop Bracket Kit

- Includes 2 drop brackets

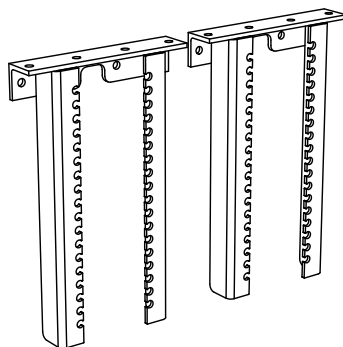

#### Optional Installation Accessories

Description	Ordering Number	Item Code	Wt. Kg.
Pole Extender Kit	MAPEK	76024	9.9
YST HD Drop Bracket Kit	YSTHDBK	79850	14.5

Lead time: 1 working day

# Section 4 – Installation Instructions

## Y-Type™ Heavy-Duty Secondary Belt Cleaner - Pull-Up Tensioning (Polyurethane or Carbide Option)

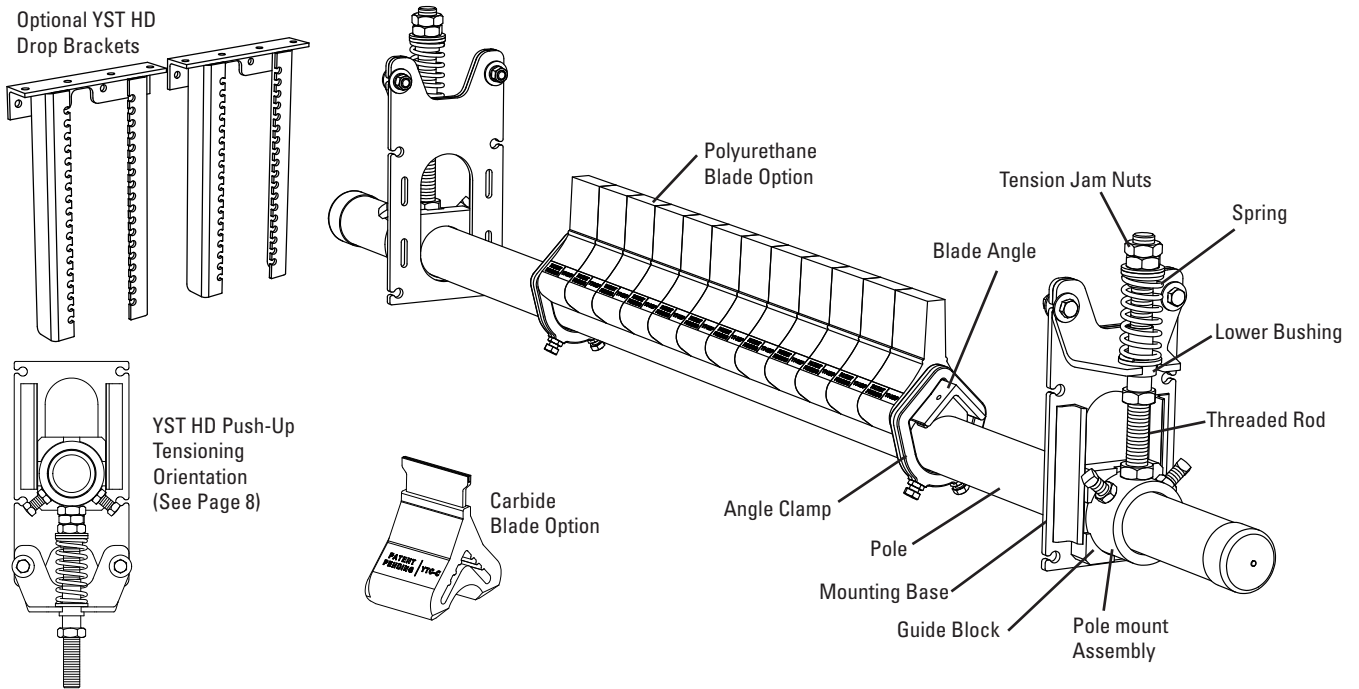

**Physically lock out and tag the conveyor at the power source before you begin cleaner installation.**

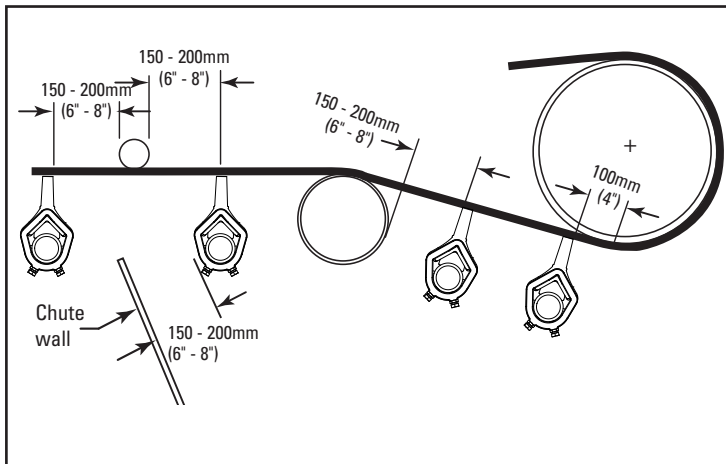

### Tools Needed

- 24mm (15/16") Wrench
- 19mm (3/4") Wrench
- 38mm (1-1/2") Wrench
- OR Large Adjustable Wrench & Channel Locks
- Tape Measure
- Ratchet with 19mm (3/4") Socket
- (2) 150mm (6") C-Clamps (for Temporary Positioning of Mounting Brackets)
- Cutting Torch and/or Welder
- Marking Pen

### Before You Begin:

- For chute mounting it may be necessary to cut an access hole to allow for installation and inspections. (See dimensions in Step 1.)
- Follow all safety precautions when using a cutting torch.
- If welding, protect all fastener threads from weld spatter.
- For cleaner clearance requirements see chart at right.

### Clearance Requirements for Installation

	Vertical	Horizontal
Y-Type Polyurethane	248mm (9-3/4")	133mm (5-1/4")
Y-Type Carbide	241mm (9-1/2")	133mm (5-1/4")

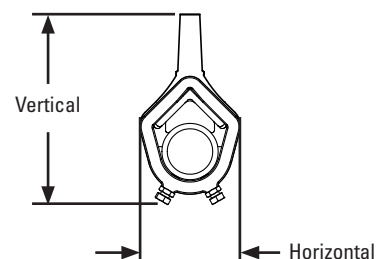

## Section 4 – Installation Instructions (cont.)

### Y-Type™ Heavy-Duty Secondary Belt Cleaner

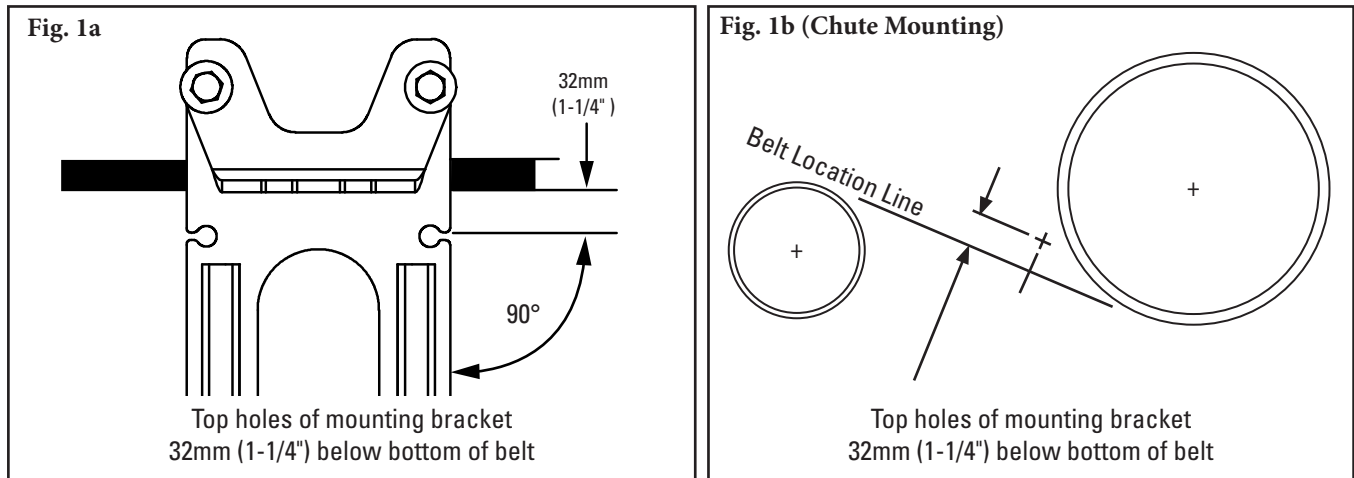

- 1. Install spring tensioner mounting bases. (For push-up tensioning refer to additional instructions on Page 8.)** Clamp mounting base into position so top flange of base is located the proper distance below bottom of belt (Fig. 1a). With angle bracket positioned as shown in Fig. 1a for pull-up tensioning, bolt first mounting base in place. Locate and mark mounting base position on other side but do not install at this time.

**For chute mounting:** For chute installation a belt location line must first be established. Draw a line on the chute replicating this location. If head pulley and snub pulley are close, it may be necessary to assume an approximate belt line between the two. In the determined location draw a line perpendicular to the belt line. Make a mark at the proper distance below bottom of belt (Fig. 1b).

Locate a mounting bracket perpendicular to belt location line (Fig. 1b), aligning top mounting bracket flange with mark made in previous step. Bolt bracket in place. Repeat this step on opposite side. Cut access holes using provided mounting template.

**NOTE: The mounting brackets must be aligned perpendicular to the belt.**

- 2. Install pole.** Insert pole assembly into installed mounting base from the inside. Then slide opposite side mounting base onto pole and bolt in place (Fig. 2).

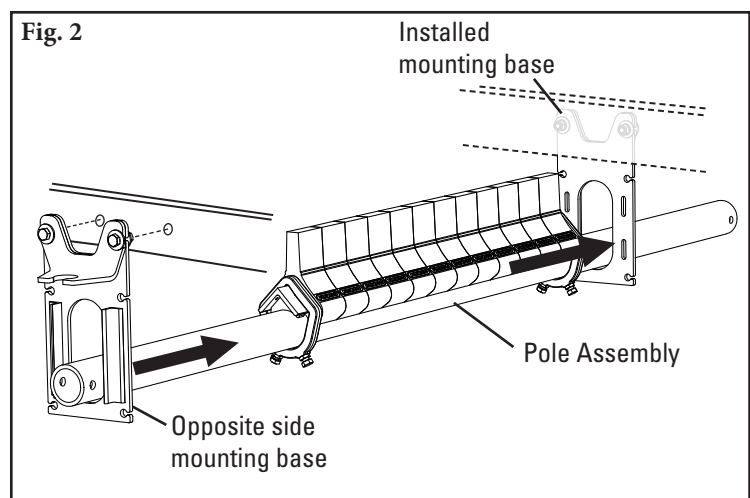



## Section 4 – Installation Instructions (cont.)

### Y-Type™ Heavy-Duty Secondary Belt Cleaner

3. **Assemble tensioners.** Slide guide blocks over each end of pole (Fig. 3a) and position in mounting base as shown (Fig. 3b). Slide tensioner assembly over each end of pole and position lower bushing into mounting base (Fig. 3b).

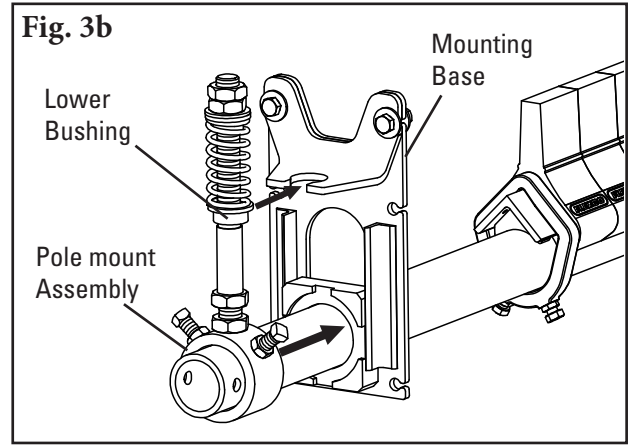
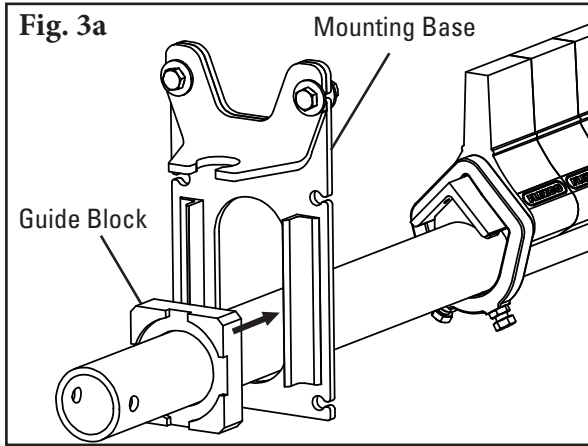

4. **Secure pole.** Center pole/blades on belt and rotate pole until blades are perpendicular to belt. Tighten the two locking bolts and nuts on each pole mount assembly to lock pole in place (Fig. 4).
5. **Set blade tension.** Loosen top tension jam nut on both sides and turn nuts until correct spring compression is reached (Fig. 5). Spring compression is determined by spring length. See chart below for correct spring length for your specific cleaner (polyurethane or carbide) and belt width.
6. **Set adjusting rod sleeve.** After setting blade tension, screw adjusting rod sleeve up into UHMW bushing until 38mm (1-1/2") is showing (Fig. 6). Tighten adjusting rod sleeve jam nut.

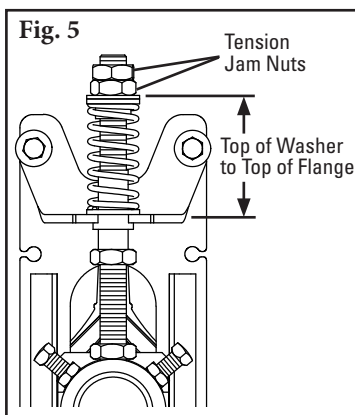
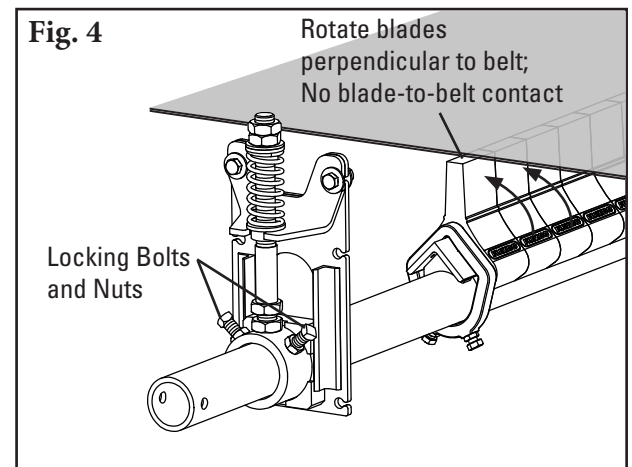

**YST HD Tensioner Spring Length Chart**

Blade Width	Carbide Tip				Polyurethane Tip				
	Silver Springs		Black Springs		Green Springs		Blue Springs		
mm	in.	mm	in.	mm	in.	mm	in.	mm	in.
900	36	98	3 7/8	102	4	76	3	86	3 3/8
1050	42	95	3 3/4	98	3 7/8	73	2 7/8	83	3 1/4
1200	48	92	3 5/8	95	3 3/4	67	2 5/8	79	3 1/8
1350	54	89	3 1/2	95	3 3/4	64	2 1/2	76	3
1500	60	86	3 3/8	92	3 5/8	NA	NA	73	2 7/8
1800	72	83	3 1/4	89	3 1/2	NA	NA	64	2 1/2

Shading indicates preferred spring option.

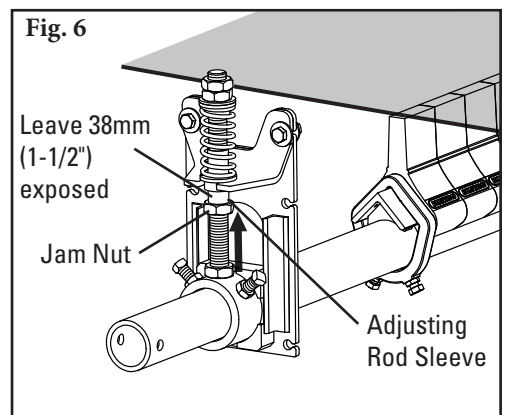

## Section 4 – Installation Instructions (cont.)

### 4.2 Y-Type™ Heavy-Duty Secondary Belt Cleaner - Push-Up Tensioning (Polyurethane or Carbide Option)

Fig. 1a

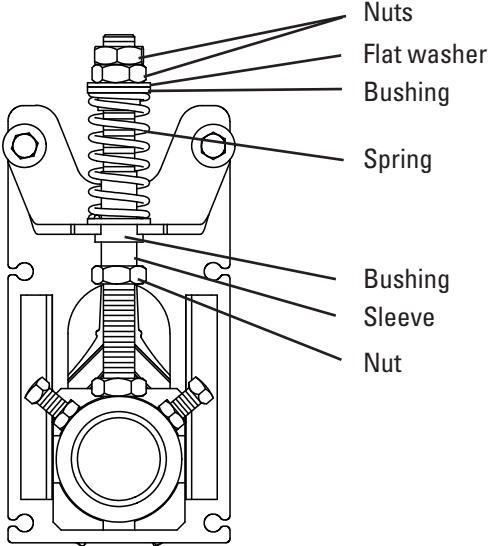
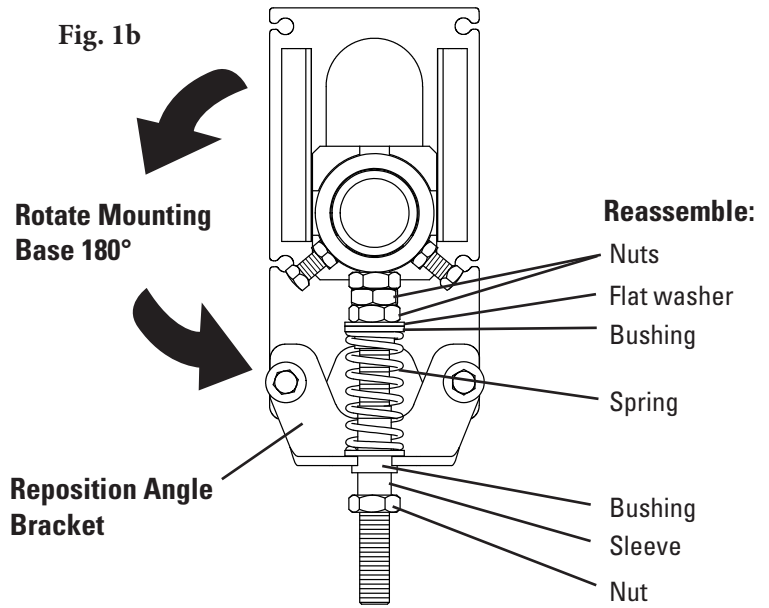
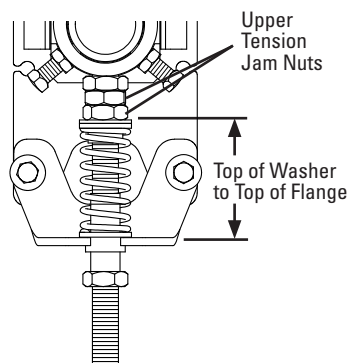
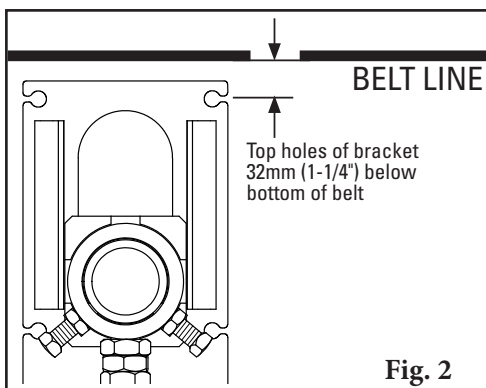

Fig. 1b



1. **Reconfigure the standard pull-up tensioner to the push-up style.** Remove 3 nuts, flat washer, 2 bushings, spring, and sleeve (Fig. 1a). Rotate the mounting base so the two flanges point downward and reposition the angle bracket as shown in Fig. 1b. Reassemble components on threaded rod in the order shown (Fig. 1b).
2. **Install the tensioner mounting bases.** Mount the bases to the structure or chute so that the tops of the bases are aligned with the bottom of the belt (urethane blades) or 14mm (9/16") above the bottom of the belt (carbide blades) (Fig. 2).
3. **Install the cleaner pole and set the blade angle.** Follow installation steps 2-4 from the cleaner instructions on Page 6 and 7. **Note:** be sure the lock bolts on the torsion pole mount have been securely tightened to lock the pole in place before moving to Step 4.
4. **Set the blade tension.** Turn the 2 upper tension nuts until the spring is compressed to the length shown on the Spring Length Chart below. Tighten the 2 tension nuts together to prevent loosening.



YST HD Tensioner Spring Length Chart

Blade Width	Carbide Tip				Polyurethane Tip				
	Silver Springs		Black Springs		Green Springs		Blue Springs		
mm	in.	mm	in.	mm	in.	mm	in.		
900	36	98	3 7/8	102	4	76	3	86	3 3/8
1050	42	95	3 3/4	98	3 7/8	73	2 7/8	83	3 1/4
1200	48	92	3 5/8	95	3 3/4	67	2 5/8	79	3 1/8
1350	54	89	3 1/2	95	3 3/4	64	2 1/2	76	3
1500	60	86	3 3/8	92	3 5/8	NA	NA	73	2 7/8
1800	72	83	3 1/4	89	3 1/2	NA	NA	64	2 1/2

Shading indicates preferred spring option.

## Section 5 – Pre-Operation Checklist and Testing

---

### 5.1 Pre-Op Checklist

- Recheck that all fasteners are tightened properly.
- Add pole caps.
- Apply all supplied labels to the cleaner.
- Check blade location on the belt.
- Be sure that all installation materials and tools have been removed from belt and conveyor area.

### 5.2 Test Run the Conveyor

- Run conveyor for at least 15 minutes and inspect the cleaning performance.
- If vibration occurs or more cleaning efficiency is desired, increase blade tension by making 3mm (1/8") compression adjustments on the tension springs.
- Check adjusting brackets and tips for proper tensioning.
- Make adjustments as necessary.

**NOTE:** Observing the cleaner when it is running and performing properly will help to detect problems and determine when adjustments are needed.

## Section 6 – Maintenance

---

Flexco belt cleaners are designed to operate with minimum maintenance. However, to maintain superior performance some service is required. When the cleaner is installed, a regular maintenance program should be set up. This program will ensure the cleaner operates at optimal efficiency and problems can be identified and fixed before the cleaner stops working.

All safety procedures for inspection of equipment (stationary or operating) must be observed. The Y-Type™ Secondary Belt Cleaner operates at the discharge end of the conveyor and is in direct contact with the moving belt. Only visual observations can be made while the belt is running. Service tasks can be done only with the conveyor stopped and by observing the correct lockout/tagout procedures.

### 6.1 New Installation Inspection

After the new cleaner has run for a few days, a visual inspection should be made to ensure the cleaner is performing properly. Make adjustments as needed.

### 6.2 Routine Visual Inspection (every 2-4 weeks)

A visual inspection of the cleaner and belt can determine if:

- Spring length is the correct length for optimal tensioning.
- Pole can move up and down with no binding of the tensioners.
- Belt looks clean or if there are areas that are dirty.
- Blade is worn out and needs to be replaced.
- There is damage to the blade or other cleaner components.
- Fugitive material is built up on the cleaner or in the transfer area.
- There is cover damage to the belt.
- There is vibration or bouncing of the cleaner on the belt.
- There is material buildup on the snub pulley (if used).
- Significant signs of carryback exist.

If any of the above conditions exist, a determination should be made on when the conveyor can be stopped for cleaner maintenance.

### 6.3 Routine Physical Inspection (every 6-8 weeks)

When the conveyor is not in operation and properly locked and tagged out, perform a physical inspection of the cleaner through the following tasks:

- Clean material buildup from cleaner blade and pole.
- Verify pole can move smoothly up and down.
- Closely inspect blade for wear and any damage. Replace if needed.
- Ensure full blade to belt contact.
- Inspect the cleaner pole for damage.
- Inspect all fasteners for tightness and wear. Tighten or replace as needed.
- Replace any worn or damaged components.
- Check the tension of the cleaner blade to the belt. Adjust the tension if necessary using the steps on page 7 or 8.
- When maintenance tasks are completed, test run the conveyor to ensure the cleaner is performing properly.

## Section 6 – Maintenance (cont.)

### 6.4 Blade Replacement Instructions (Polyurethane or Carbide)

#### BEFORE YOU BEGIN:

Physically Lock Out and Tag the Conveyor at the Power Source.

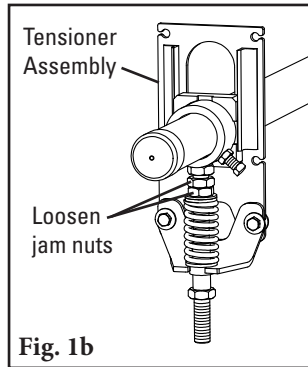
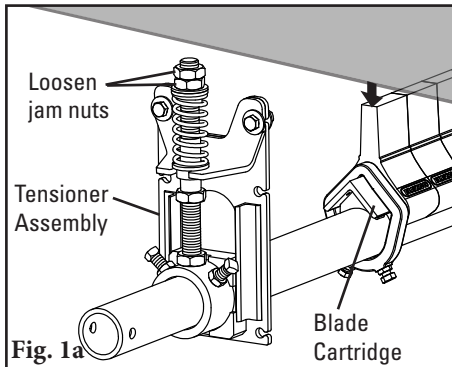

#### 1. Lower cleaner away from belt.

Loosen jam nuts on threaded rods to remove tension and lower the cleaner (Fig. 1a - Pull-up Tensioning; Fig. 1b - Push-up Tensioning). If mounted on a chute, remove near side tensioner assembly to access blade cartridge.

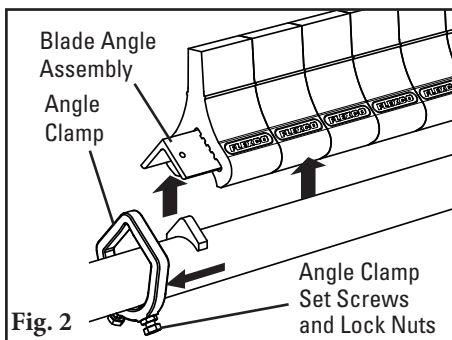

2. **Remove blade angle from pole.** Loosen angle clamp lock nuts and set screws on both sides of cleaner (Fig. 2). Slide angle clamps off each end of the angle and remove blade angle assembly from pole.

3. **Replace cushions.** Cushions may be removed from angle by sliding them off each end, or entire angle with all cushions may be replaced at once.

4. **Reinstall blade angle.** Set new cushions and angle back on pole and slide angle clamps back onto the angle (Fig. 3). Tighten angle clamp set screws and lock nuts on both sides. Verify blades are centered and perpendicular to belt.

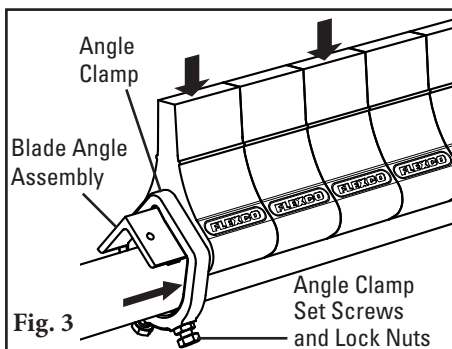

5. **Set blade tension.** Turn adjustment nuts until correct spring compression is reached (Fig 4). Spring compression is determined by spring length. See chart below for correct spring length for your belt width.

6. **Test run cleaner and inspect cleaning performance.** If vibration occurs or more cleaning efficiency is desired, increase blade tension by making 3mm (1/8") compression adjustments on tension springs.

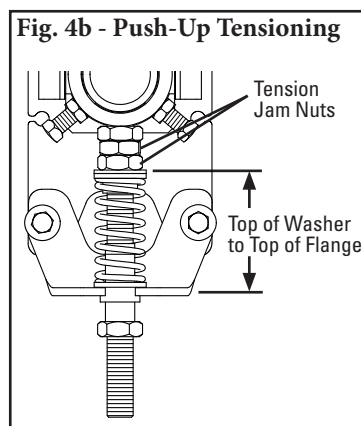
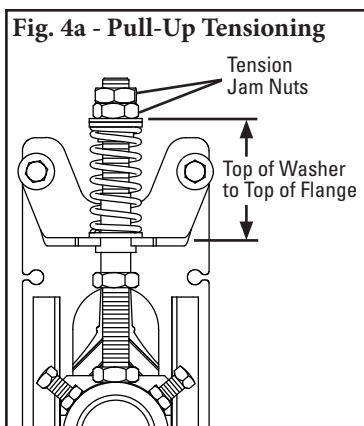

#### YST HD Tensioner Spring Length Chart

Blade Width		Carbide Tip		Polyurethane Tip					
		Silver Springs	Black Springs	Green Springs	Blue Springs				
mm	in.	mm	in.	mm	in.	mm	in.		
900	36	98	3 7/8	102	4	76	3	86	3 3/8
1050	42	95	3 3/4	98	3 7/8	73	2 7/8	83	3 1/4
1200	48	92	3 5/8	95	3 3/4	67	2 5/8	79	3 1/8
1350	54	89	3 1/2	95	3 3/4	64	2 1/2	76	3
1500	60	86	3 3/8	92	3 5/8	NA	NA	73	2 7/8
1800	72	83	3 1/4	89	3 1/2	NA	NA	64	2 1/2

Shading indicates preferred spring option.

## Section 6 – Maintenance (cont.)

---

### 6.5 Maintenance Log

Conveyor Name/No. \_\_\_\_\_

Date: \_\_\_\_\_ Work done by: \_\_\_\_\_ Service Quote #: \_\_\_\_\_

Activity: \_\_\_\_\_

---

Date: \_\_\_\_\_ Work done by: \_\_\_\_\_ Service Quote #: \_\_\_\_\_

Activity: \_\_\_\_\_

---

Date: \_\_\_\_\_ Work done by: \_\_\_\_\_ Service Quote #: \_\_\_\_\_

Activity: \_\_\_\_\_

---

Date: \_\_\_\_\_ Work done by: \_\_\_\_\_ Service Quote #: \_\_\_\_\_

Activity: \_\_\_\_\_

---

Date: \_\_\_\_\_ Work done by: \_\_\_\_\_ Service Quote #: \_\_\_\_\_

Activity: \_\_\_\_\_

---

Date: \_\_\_\_\_ Work done by: \_\_\_\_\_ Service Quote #: \_\_\_\_\_

Activity: \_\_\_\_\_

---

Date: \_\_\_\_\_ Work done by: \_\_\_\_\_ Service Quote #: \_\_\_\_\_

Activity: \_\_\_\_\_

---

Date: \_\_\_\_\_ Work done by: \_\_\_\_\_ Service Quote #: \_\_\_\_\_

Activity: \_\_\_\_\_

---

## Section 6 – Maintenance (cont.)

### 6.6 Cleaner Maintenance Checklist

Site: \_\_\_\_\_ Inspected by: \_\_\_\_\_ Date: \_\_\_\_\_

Belt Cleaner: \_\_\_\_\_ Serial Number: \_\_\_\_\_

#### Beltline Information:

Beltline Number: \_\_\_\_\_ Belt Condition: \_\_\_\_\_

Belt Width:  900mm (36")  1050mm (42")  1200mm (48")  1350mm (54")  1500mm (60")  1800mm (72")

Head Pulley Diameter (Belt & Lagging): \_\_\_\_\_ Belt Speed: \_\_\_\_\_ fpm Belt Thickness: \_\_\_\_\_

Belt Splice: \_\_\_\_\_ Condition of Splice: \_\_\_\_\_ Number of Splices: \_\_\_\_\_  Skived  Unskived

Material conveyed: \_\_\_\_\_

Days per week run: \_\_\_\_\_ Hours per day run: \_\_\_\_\_

#### Blade Life:

Date blade installed: \_\_\_\_\_ Date blade inspected: \_\_\_\_\_ Estimated blade life: \_\_\_\_\_

Is blade making complete contact with belt?  Yes  No

Blade wear: Left \_\_\_\_\_ Middle \_\_\_\_\_ Right \_\_\_\_\_

Blade condition:  Good  Grooved  Smiled  Not contacting belt  Damaged

Measurement of spring: Required \_\_\_\_\_ Currently \_\_\_\_\_

Was Cleaner Adjusted:  Yes  No

Pole Condition:  Good  Bent  Worn

Lagging:  Side Lag  Ceramic  Rubber  Other  None

Condition of lagging:  Good  Bad  Other \_\_\_\_\_

Cleaner's Overall Performance: (Rate the following 1 - 5, 1= very poor - 5 = very good)

Appearance:  Comments: \_\_\_\_\_

Location:  Comments: \_\_\_\_\_

Maintenance:  Comments: \_\_\_\_\_

Performance:  Comments: \_\_\_\_\_

Other comments: \_\_\_\_\_

\_\_\_\_\_

\_\_\_\_\_

\_\_\_\_\_

\_\_\_\_\_

\_\_\_\_\_

\_\_\_\_\_

## Section 7 – Troubleshooting

Problem	Possible Cause	Possible Solutions
Vibration	Cleaner secure bolts not set	Ensure all locking nuts are tight (Loctite)
	Cleaner not set up correctly	Ensure cleaner set up properly (check tip angle)
	Belt tension too high	Ensure cleaner can conform to belt, or replace with alternate Flexco® secondary cleaner
	Belt flap	Introduce hold-down roller to flatten belt
	Cleaner over-tensioned	Ensure cleaner is correctly tensioned
	Cleaner under-tensioned	Ensure cleaner is correctly tensioned
Material buildup on cleaner	Cleaner not set up correctly	Ensure cleaner set up properly (check tip angle)
	Buildup on chute	Ensure cleaner is not located too close to back of chute, allowing buildup
	Cleaner being overburdened	Introduce Flexco precleaner
	Excessive sticky material	Frequently clean unit of buildup
Cleaner not conforming to belt	Cleaner not set up correctly	Ensure cleaner set up properly (check tip angle)
	Belt tension too high	Ensure cleaner can conform to belt, introduce hold-down roller, or replace with alternate Flexco secondary cleaner
	Belt flap	Introduce hold-down roller to flatten belt
	Cleaner cannot conform	Ensure cleaner can conform to belt, introduce hold-down roller, or replace with alternate Flexco secondary cleaner
Material passing cleaner	Cleaner not set up correctly	Ensure cleaner set up properly (check tip angle)
	Cleaner tension too low	Ensure cleaner is correctly tensioned
	Cleaner blade worn/damaged	Check blade for wear, damage and chips, replace where necessary
	Cleaner being overburdened	Introduce Flexco precleaner
	Belt flap	Introduce hold-down roller to flatten belt
	Belt worn or grooved	Introduce water spray pole
	Cleaner cannot conform	Ensure cleaner can conform to belt, introduce hold-down roller, or replace with alternate Flexco secondary cleaner
Missing material in belt center only	Cupped Belt	Install hold-down roller and reset blade angle
	Cleaner blade worn/damaged	Check blade for wear, damage and chips, replace where necessary
Missing material on outer edges only	Cupped Belt	Install hold-down roller and reset blade angle
	Cleaner blade worn/damaged	Check blade for wear, damage and chips, replace where necessary
Tensioners binding	Tensioners not aligned properly	Adjust mounting bases until tensioners travel without binding



# Section 8 – Specifications and CAD Drawings

## 8.1 Specifications and Guidelines

### Pole Length Specifications

Cleaner Size		Pole Length		Maximum Conveyor Span	
mm	in.	mm	in.	mm	in.
900	36	2286	90	2083	82
1050	42	2438	96	2235	88
1200	48	2590	102	2388	94
1350	54	2743	108	2540	100
1500	60	2895	114	2692	106
1800	72	3200	126	2997	118

Pole Length - Belt +1350mm (54")  
 Pole Diameter - 73mm (2-7/8")

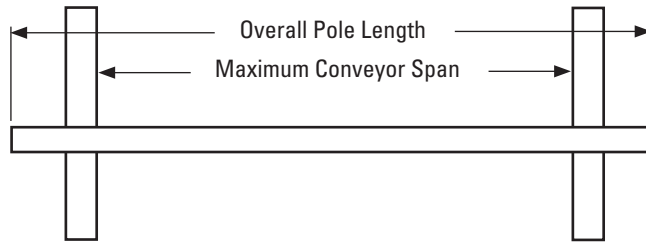

### Clearance Guidelines for Installation

Cleaner Type	Belt Width/ Cleaner Size		Horizontal Clearance Required		Vertical Clearance Required	
	mm	in.	mm	in.	mm	in.
Y-Type® HD Polyurethane	900 - 1800	36 - 72	133	5-1/4	241	9-1/2
Y-Type HD Carbide	900 - 1800	36 - 72	133	5-1/4	248	9-3/4

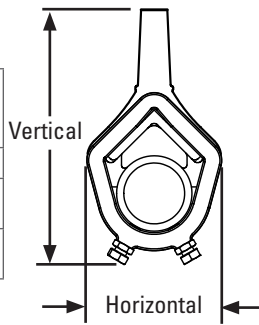

### Y-Type Blade Specifications

Cushion	Durometer	Temperature Range
Purple (Standard)	86A	-35° to 82° C -30° to 180° F
White (Food Grade)‡	83A	-35° to 82° C -30° to 180° F
Red (Ultra High-Temp)	90A	Up to 400° F (200° C) Spikes to 450° F (232° C)
Carbide	n/a	-35° to 82° C -30° to 180° F

‡All ingredients used in the polyurethane formulation of this blade comply with the relevant requirements of 21 CFR (FDA Code of Federal Regulations) for use in repeated bulk dry food applications

### YST HD Tensioner Spring Length Chart

Blade Width	Carbide Tip				Polyurethane Tip				
	Silver Springs		Black Springs		Green Springs		Blue Springs		
mm	in.	mm	in.	mm	in.	mm	in.	mm	in.
900	36	98	3 7/8	102	4	76	3	86	3 3/8
1050	42	95	3 3/4	98	3 7/8	73	2 7/8	83	3 1/4
1200	48	92	3 5/8	95	3 3/4	67	2 5/8	79	3 1/8
1350	54	89	3 1/2	95	3 3/4	64	2 1/2	76	3
1500	60	86	3 3/8	92	3 5/8	NA	NA	73	2 7/8
1800	72	83	3 1/4	89	3 1/2	NA	NA	64	2 1/2

Shading indicates preferred spring option.

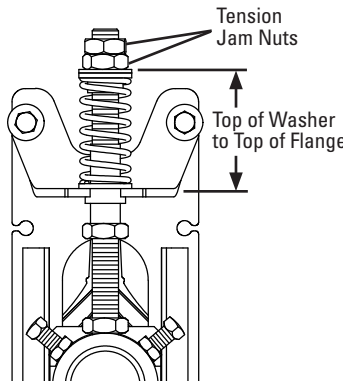

Pull-Up Tensioner Configuration (HD)

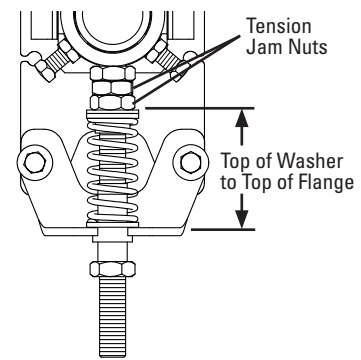

Push-Up Tensioner Configuration (HD)

### Specifications:

- Maximum Belt Speed.....3.8M/sec (750 FPM)
- Usable Blade Wear Length.....76mm (3") (Polyurethane)  
10mm (3/8") (Carbide)
- Blade Materials .....**Purple:** Polyurethane (proprietary blend for abrasion resistance and long wear)  
**White:** Polyurethane (chemical resistant/food grade)  
**Red:** Polyurethane (ultra high-temp)  
**Carbide:** Tungsten Carbide
- Available for Belt Widths.....900 to 1800mm (36" to 72"). Other sizes available upon request
- CEMA Cleaner Rating .....Class 3 (Heavy-duty with polyurethane or carbide blades)

# Section 8 – Specifications and CAD Drawings (cont.)

## 8.2 CAD Drawing – Y-Type™ HD Polyurethane

SPECIFICATIONS			PURPLE BLADES		WHITE BLADES		RED BLADES	
BELT WIDTH 'A'		POLE LENGTH 'B'	ORDER NUMBER	ITEM CODE	ORDER NUMBER	ITEM CODE	ORDER NUMBER	ITEM CODE
in	mm	in	mm					
36	900	90	2286	YTHD-36S	79783	YTHDW-36S	79789	YTHDR-36S
42	1050	96	2438	YTHD-42S	79784	YTHDW-42S	79790	YTHDR-42S
48	1200	102	2590	YTHD-48S	79785	YTHDW-48S	79791	YTHDR-48S
54	1350	108	2743	YTHD-54S	79786	YTHDW-54S	79792	YTHDR-54S
60	1500	114	2895	YTHD-60S	79787	YTHDW-60S	79793	YTHDR-60S
72	1800	126	3200	YTHD-72S	79788	YTHDW-72S	79794	YTHDR-72S

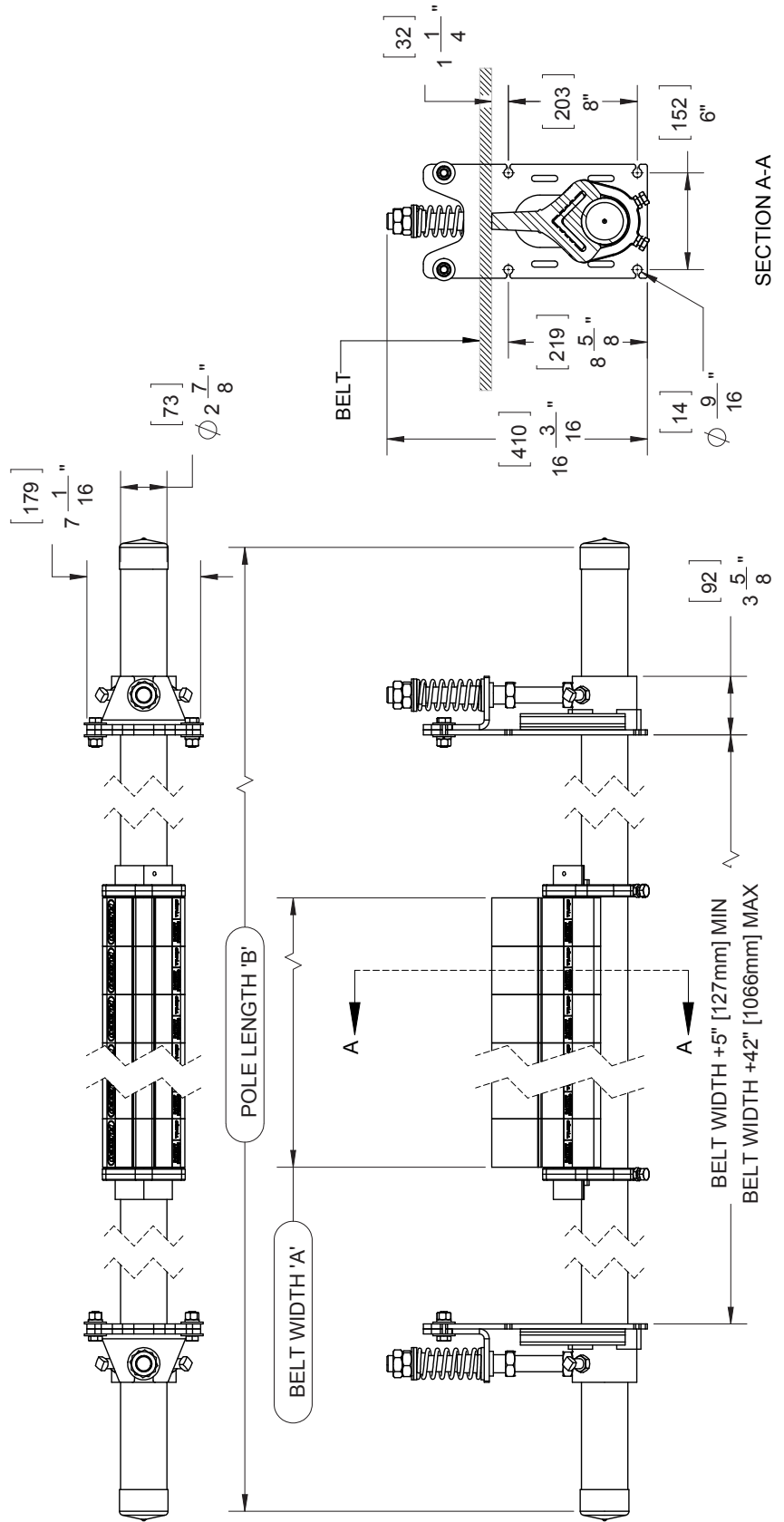

# Section 8 – Specifications and CAD Drawings (cont.)

## 8.3 CAD Drawing – Y-Type™ HD Carbide

SPECIFICATIONS			ITEM CODE	
BELT WIDTH 'A'	POLE LENGTH 'B'	ORDER NUMBER		
(IN)	(IN)	(mm)		
36	90	2286	YTHD-TC-36S 79777	
42	1050	96	2438	YTHD-TC-42S 79778
48	1200	102	2590	YTHD-TC-48S 79779
54	1350	108	2743	YTHD-TC-54S 79780
60	1500	114	2895	YTHD-TC-60S 79781
72	1800	126	3200	YTHD-TC-72S 79782

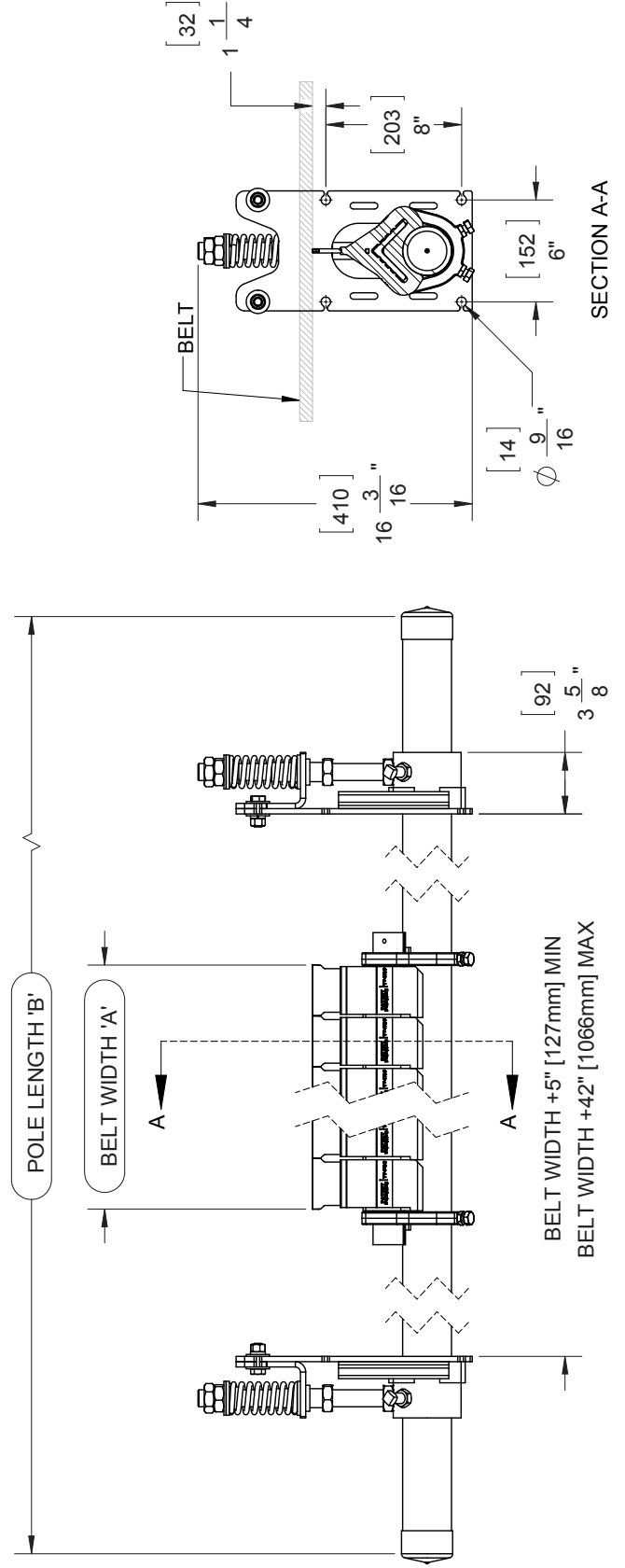
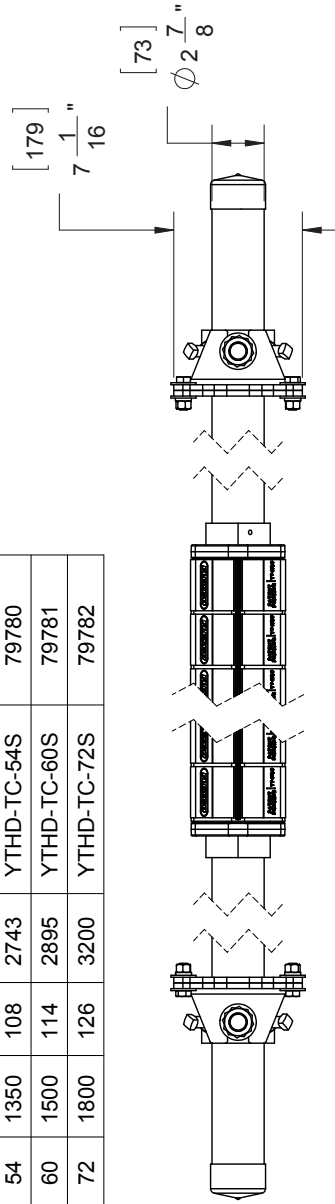

# Section 9 – Replacement Parts List

## 9.1 Replacement Parts List- Y-Type™ HD Secondary Belt Cleaner

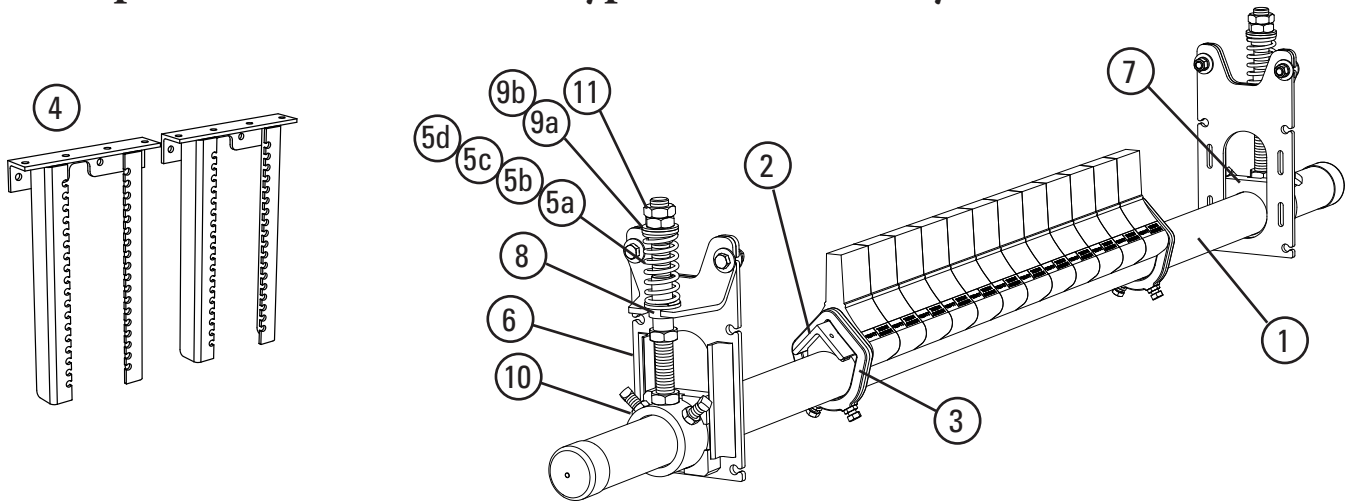

### Replacement Parts

REF	DESCRIPTION	ORDERING NUMBER	ITEM CODE	WT. KG.
1	900mm (36") Y-Type™ HD Pole	YTPHD-36/900	79799	27.3
	1050mm (42") Y-Type HD Pole	YTPHD-42/1050	79800	28.8
	1200mm (48") Y-Type HD Pole	YTPHD-48/1200	79801	30.4
	1350mm (54") Y-Type HD Pole	YTPHD-54/1350	79802	31.9
	1500mm (60") Y-Type HD Pole	YTPHD-60/1500	79803	33.5
	1800mm (72") Y-Type HD Pole	YTPHD-72/1800	79804	35.0
2	900mm (36") Y-Type HD Cushion Angle	YTAHD-36/900	79805	7.5
	1050mm (42") Y-Type HD Cushion Angle	YTAHD-42/1050	79806	8.6
	1200mm (48") Y-Type HD Cushion Angle	YTAHD-48/1200	79807	9.7
	1350mm (54") Y-Type HD Cushion Angle	YTAHD-54/1350	79808	10.9
	1500mm (60") Y-Type HD Cushion Angle	YTAHD-60/1500	79809	12.0
	1800mm (72") Y-Type HD Cushion Angle	YTAHD-72/1800	79810	14.2
3	Y-Type HD Angle Clamp* (2 Clamps)	YTACHD	79835	2.2
4	YST HD Drop Bracket Kit (2 Brackets)	YSTDDBK	79850	14.6
5a	YST HD Spring, Green	YSTDHS-GR	79797	0.2
5b	SST Spring, Silver	STS-S	75843	0.4
5c	YST HD Spring, Blue (for Y-Type HD Carbide Cleaners)	YSTDHS-BL	79798	0.3
5d	SST Spring, Black (for Y-Type HD Carbide Cleaners)	STS-B	75844	0.5
6	YST HD Mounting Bracket (incl. Angle Bracket)	YSTDHMB	79849	3.0
7a	YST HD Guide Block Kit (Pair)	YSTDHGBK	79851	0.05
7b	YST HD Guide Block Kit UHT (Pair)	YSTDHGBK-R	91829	0.05
8a	YST HD Lower Bushing Kit (Pair)	YSTDHLBK	79852	0.05
8b	YST HD Lower Bushing Kit UHT (Pair)	YSTDHLBK-R	91830	0.05
9a	YST HD Top Bushing Kit White (Pair)	YSTDHBK-W	79853	0.05
9b	YST HD Top Bushing Kit Black (Pair)	YSTDHBK-B	79856	0.05
9c	YST HD Top Bushing Kit Green (Pair)	YSTDHBK-GR-R	91832	0.05
9d	YST HD Top Bushing Kit Blue (Pair)	YSTDHBK-BL-R	91831	0.05
10	YST HD Pole Mount Kit*	YSTDHDMK	79854	3.5
11	YST HD Adjusting Rod Nut Kit	YSTDANKHD	79858	0.3
-	YST Tensioner w/Silver Spring (Pair) (for belts 900 - 1350mm (36" - 54") w/carbide tips) (incl. 2 ea. item 5b, 6, 10, 11; 1 ea. items 7a, 8a, 9a)	YSTDH-S	79840	15.2
-	YST Tensioner w/Black Spring (Pair) (for belts 1500 - 1800mm (60" - 72") w/carbide tips) (incl. 2 ea. item 5d, 6, 10, 11; 1 ea. items 7a, 8a, 9b)	YSTDH-BK	79842	15.5
-	YST Tensioner w/Green Spring (Pair) (for belts 900 - 1200mm (36" - 48") w/Polyurethane tips) (incl. 2 ea. item 5a, 6, 10, 11; 1 ea. items 7a, 8a, 9a)	YSTDH-GR	79839	14.9
-	YST Tensioner w/Blue Spring (Pair) (for belts 1350 - 1800mm (54" - 72") w/Polyurethane tips) (incl. 2 ea. item 5c, 6, 10, 11; 1 ea. items 7a, 8a, 9b)	YSTDH-BL	79841	15.0
-	YST Tensioner w/Green Spring UHT (Pair) (for belts 36" - 48" w/UHT Polyurethane tips) (incl. 2 ea. item 5a, 6, 10, 11; 1 ea. items 7b, 8b, 9c)	YSTDH-GR-R	91833	14.9
-	YST Tensioner w/Blue Spring UHT (Pair) (for belts 54" - 72" w/UHT Polyurethane tips) (incl. 2 ea. item 5c, 6, 10, 11; 1 ea. items 7b, 8b, 9d)	YSTDH-BL-R	91834	15.0

\*Hardware included Lead time: 1 working day

### Replacement Blades/Blade Cartridges

REF	DESCRIPTION	ORDERING NUMBER	ITEM CODE	WT. KG.
12	Y-Type HD Carbide Blade (single)	YT-HDC	79728	0.9
13	900mm (36") Y-Type HD Carbide Blade Cartridge	YCART-36/900-HDTC	79829	17.5
	1050mm (42") Y-Type HD Carbide Blade Cartridge	YCART-42/1050-HDTC	79830	20.2
	1200mm (48") Y-Type HD Carbide Blade Cartridge	YCART-48/1200-HDTC	79831	23.0
	1350mm (54") Y-Type HD Carbide Blade Cartridge	YCART-54/1350-HDTC	79832	25.8
	1500mm (60") Y-Type HD Carbide Blade Cartridge	YCART-60/1500-HDTC	79833	28.6
	1800mm (72") Y-Type HD Carbide Blade Cartridge	YCART-72/1800-HDTC	79834	34.1
14	Y-Type HD Purple Polyurethane Blade (single)	YT-HDP	79677	0.8
15	900mm (36") Y-Type HD Purple Blade Cartridge	YCART-36/900-HDP	79817	16.6
	1050mm (42") Y-Type HD Purple Blade Cartridge	YCART-42/1050-HDP	79818	19.2
	1200mm (48") Y-Type HD Purple Blade Cartridge	YCART-48/1200-HDP	79819	21.9
	1350mm (54") Y-Type HD Purple Blade Cartridge	YCART-54/1350-HDP	79820	54.0
	1500mm (60") Y-Type HD Purple Blade Cartridge	YCART-60/1500-HDP	79821	24.5
	1800mm (72") Y-Type HD Purple Blade Cartridge	YCART-72/1800-HDP	79822	32.4
16	Y-Type HD White Polyurethane Blade (single)	YT-HDW	79676	0.8
17	900mm (36") Y-Type HD White Blade Cartridge	YCART-36/900-HDW	79823	16.6
	1050mm (42") Y-Type HD White Blade Cartridge	YCART-42/1050-HDW	79824	19.2
	1200mm (48") Y-Type HD White Blade Cartridge	YCART-48/1200-HDW	79825	21.9
	1350mm (54") Y-Type HD White Blade Cartridge	YCART-54/1350-HDW	79826	24.5
	1500mm (60") Y-Type HD White Blade Cartridge	YCART-60/1500-HDW	79827	27.1
	1800mm (72") Y-Type HD White Blade Cartridge	YCART-72/1800-HDW	79828	32.4
18	Y-Type HD Red Polyurethane Blade (single)	YT-HDR	91823	0.8
19	900mm (36") Y-Type HD Red Blade Cartridge	YCART-36/900-HDR	91824	16.6
	1050mm (42") Y-Type HD Red Blade Cartridge	YCART-42/1050-HDR	91825	19.2
	1200mm (48") Y-Type HD Red Blade Cartridge	YCART-48/1200-HDR	91826	21.9
	1350mm (54") Y-Type HD Red Blade Cartridge	YCART-54/1350-HDR	91827	24.5
	1500mm (60") Y-Type HD Red Blade Cartridge	YCART-60/1500-HDR	91828	27.1
	1800mm (72") Y-Type HD Red Blade Cartridge	YCART-72/1800-HDR	91829	32.4

Lead time: 1 working day

### Spring Tensioner Selection Chart

Cleaner Blade Width	Silver YSTDH-S	Black YSTDH-BK	Green YSTDH-GR	Blue YSTDH-BL
Carbide 900 - 1350mm (36" - 54")	X			
Carbide 1500 - 1800mm (60" - 72")		X		
Polyurethane 900 - 1200mm (36" - 48")			X	
Polyurethane 1350 - 1800mm (54" - 72")				X

### Blades Required per Cleaner Size

mm	900	1050	1200	1350	1500	1800
in.	36	42	48	54	60	72
<b>Blades Required</b>	12	14	16	18	20	24





## Section 10 – Other Flexco Conveyor Products

---

Flexco provides many conveyor products that help your conveyors to run more efficiently and safely. These components solve typical conveyor problems and improve productivity.

Here is a quick overview on just a few of them:

### EZP1 Precleaner



- Patented ConShear™ blade renews its cleaning edge as it wears
- Visual Tension Check™ for optimal blade tensioning and simple retensioning
- Quick and easy one-pin blade replacement
- Material Path Option™ for optimal cleaning and reduced maintenance

### Inspection Door



- Multiple door sizes available for a variety of applications.
- Dust-tight silicone seal between mounting plate and chute wall.
- Latch mechanism is designed to allow easy adjustability to tightness of door seal.
- Optional hinged, bolted screen allows safe visual inspection and does not require removal for authorized workers to access the chute.

### Flexco Specialty Belt Cleaners



- “Limited space” cleaners for tight conveyor applications
- High Temp cleaners for severe, high-heat applications
- A rubber fingered cleaner for chevron and raised-rib belts
- Multiple cleaner styles in stainless steel for corrosive applications

### Flexco Slider and Impact Beds

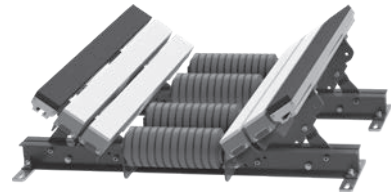

- Adjusting troughing angles for easy installation and adjustability
- Long-wearing UHMW for sealing the load zone
- Offered in both Light & Medium-duty designs to affordably fit your application

### PT Smart™ Belt Trainer



- Patented “pivot & tilt” design for superior training action
- Dual sensor rollers on each side to minimize belt damage
- Pivot point guaranteed not to seize or freeze up
- Simple brackets and component construction ensure a quick and easy installation

### Belt Plows



- A belt cleaner for the tail pulley
- Exclusive blade design quickly spirals debris off the belt
- Economical and easy to service
- Available in vee or diagonal models

Flexco Europe GmbH • Maybachstrasse 9 • 72348 Rosenfeld • Germany  
Tel: +49-7428-9406-0 • Fax: +49-7428-9406-260 • E-mail: [europa@flexco.com](mailto:europa@flexco.com)

Visit [www.flexco.com](http://www.flexco.com) for other Flexco locations and products.

©2021 Flexible Steel Lacing Company. 11/03/21. For reorder: X6282

