

What Affects Conveyor Roller Life?

How long does a roller last?

Most rollers are selected on the basis of CEMA (Conveyor Equipment Manufacturers Association), which uses theoretical bearing life calculations to determine which rollers are recommended based mainly on load and speed. According to CEMA, "idler life is determined by many factors, such as seals, bearings, shell thickness, belt speed, lump size/material density, maintenance, environment, temperature, and the proper CEMA series of idler to handle the maximum calculated idler load." And while all the variables listed above can affect the life of the roller, the only variable for which laboratory tests have provided standard value is the bearing rating.

In an ideal situation, rollers would last as long as the bearings last. Eventually, they would just wear out, due to metal fatigue. But each application presents environments and applications that simply can't be taken into account during laboratory testing. This situation is what is referred to as "design life vs. actual life," or the time the roller is supposed to last based on testing in laboratory conditions versus the time the roller will actually last in day-to-day working conditions.

Modes of Roller Failure

While CEMA states that there are many different causes of roller failure, the most common are abrasion, corrosion, seal effectiveness, and end design failure. Regular surface wear, or abrasion, from belt contact can limit the roller life. The increasing use of polymers (like engineered Nylon and HDPE) instead of steel can be useful in combating this type of roll failure. And in this case, corrosion is directly related to abrasion in the sense that the more corrosion you have, the more the rate of abrasion accelerates as the surface continues to weaken.

Seal design and effectiveness are both key to the success of the bearing and, in turn, to the success of the roller. A seal design that is resistant to moisture and other fines protects the roller from internal corrosion. It is estimated that 43 percent of bearing failures come from moisture and other contaminants. One way to prevent this is by opting for a roller with a quality "centrifugal flinger seal." This feature offers up to nine times more centrifugal force, to help "spin out" fines, water, and other contaminants. The design of the flinger seal discourages the entry of contaminants and protects the bearing inside the roller.

End disks may be made of durable materials, but the method used to join the end disk to the core can make an impact on the life of your roller. Every roller has a core and roller end piece(s), and if they come apart, the result can be disastrous for your belt. In the case of steel, the end disk separating from the core will act like a sharp knife, cutting the belt. With many composite rollers, the end disk can work loose, allowing contaminants to enter the bearing.

What can happen if your roller fails prematurely?

Regardless of the type of roller you install, preventative maintenance is one of the most important parts of roller success. Inspecting the rollers on your line, much like you inspect the other components of your belt conveyor system, is an important task. When a roller prematurely fails, the end result may not simply be a quick shut-down, replacement, and start up. Depending on the mode of failure, a premature roller breakdown can actually cause a catastrophic belt failure. Belts can be ripped by a loose end assembly, causing safety hazards and the potential for a lengthy belt shut-down, not to mention the cost of replacement belting, generally the most expensive component on a belt conveyor system.

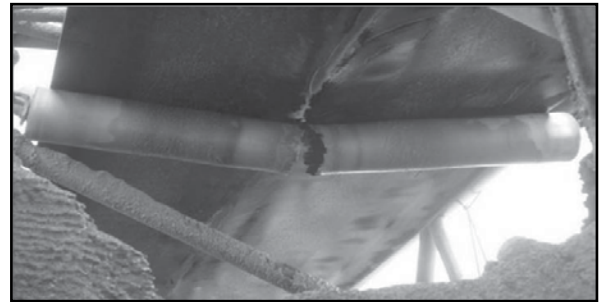

Center wear can be so drastic that it cuts your belt like a knife.

In a study comparing the abrasion resistance of steel to other common materials in sand slurry testing, all but polypropylene were significantly more resistant than steel.

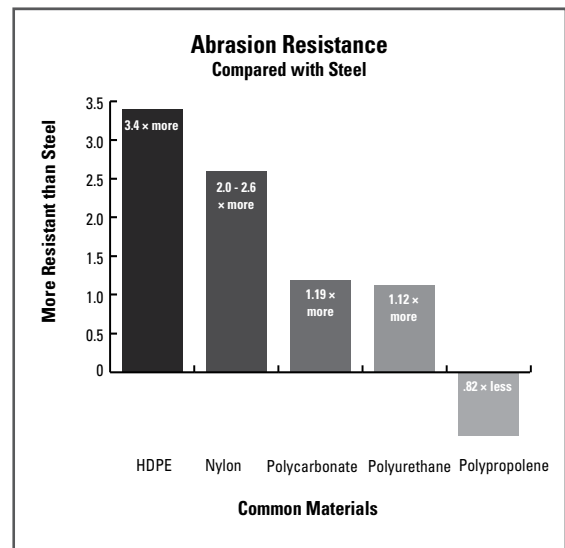

Choosing the correct rollers for your application

The first rule of thumb when choosing rollers that will last is to consider your environment, the application in which they will be used, the belt speed, and the size of your material load. These factors, as well as the size of your rollers and the number of rollers you need, should be a good starting point when choosing your rollers.

The CEMA (Conveyor Equipment Manufacturers Association) manual contains detailed information on proper roller selection. Once you define the requirements and the appropriate CEMA rating, you should then make sure the product selected meets the overall requirements of your operation. This includes making the product as safe and manageable as possible for your employees.

CoreTech™ Rollers from Flexco

CoreTech™ rollers offer the absolute best combination of structural strength coupled with the requirements of mining, which include corrosion resistance, excellent abrasion resistance, and very low surface friction.

The process used to join the end disk to the core of CoreTech rollers, sets them apart from the competition. While other composite rolls use "pressed" housings that can gradually pop out from the core, the welded bearing housing on CoreTech rollers make the end the strongest part of the entire roll.

CoreTech™ Seal Design

Available in both engineered Nylon and HDPE, CoreTech rollers feature a flinger seal that keeps material from resting in the bearing, causing corrosion or seizing. Allowing the bearing to live to its fullest possible life (or L10 life) means the operator is getting the most for the investment.

Field-proven seal design is the key to CoreTech™ roller life. The centrifugal seal rotates with the roller and creates forces up to 9x gravity.



To obtain further information, request a consultation with a Territory Sales Representative by visiting www.flexco.com/contactus.

Av. Jorge Alessandri 11.500 – Edificio 7 • Megacentro San Bernardo
San Bernardo • Santiago, Chile
Teléfono: 56-2-2896-7870 • Correo electrónico: ventaslatam@flexco.com

Visit www.flexco.com for other Flexco locations and products.

©2011 Flexible Steel Lacing Company. 03-06-20. For Reorder: X6173



CoreTech™ Verified Solution

CoreTech rollers last three times longer than steel in slurry abrasion tests. In laboratory testing, the materials used in the construction of CoreTech Nylon and HDPE rollers are proven to be the best in sand slurry abrasion testing. Carbon steel is known to not be as effective in this testing.

In water ingress testing, CoreTech rollers performed well, with minimal water absorbing into the shell, and none penetrating the bearing housing. In dust ingress testing, the weight of the roller did not change since no particles penetrated the CoreTech seal.

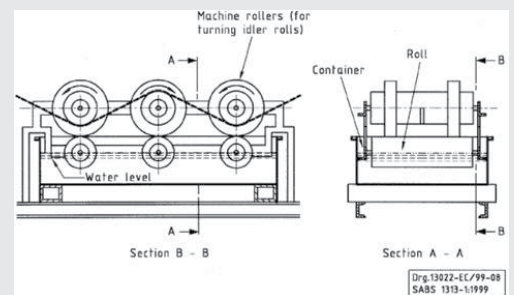

Resistance to Water Ingress (5")		
Before Test	96 hours	Water Ingress Total
6383 g	6459 g	76 g

Resistance to Water Ingress (6")		
Before Test	96 hours	Water Ingress Total
5286 g	5431 g	145 g

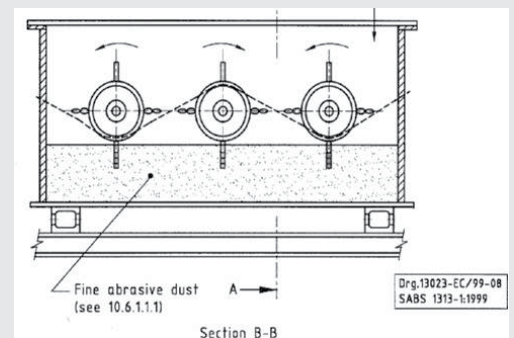

Resistance to Dust Ingress (5")		
Before Test	96 hours	Dust Ingress Total
5274 g	5274 g	0 g



Partners in Productivity