

MHS HD ATEX Secondary Cleaner

Installation, Operation and Maintenance Manual

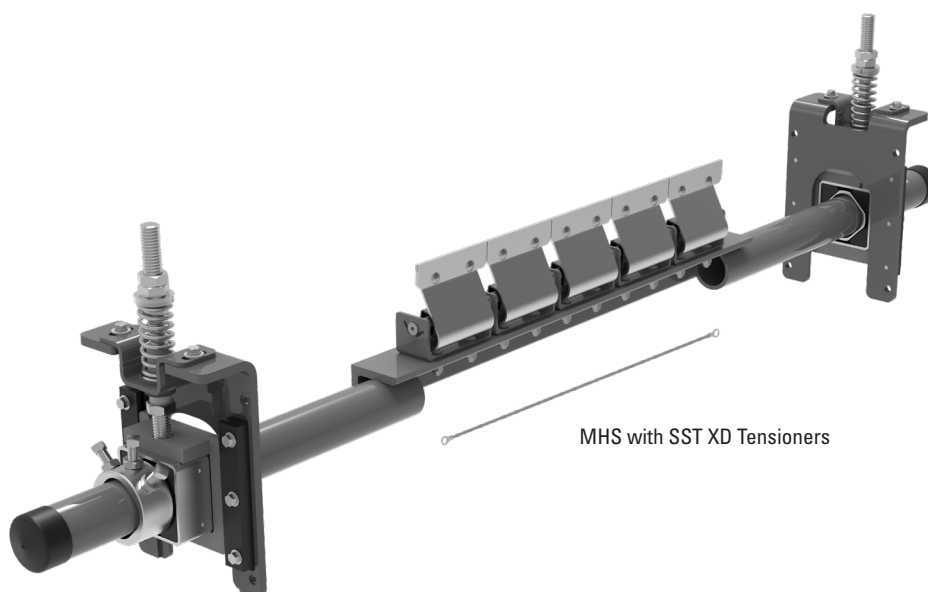

MHS HD ATEX Secondary Cleaner

Serial Number: _____

Purchase Date: _____

Purchased From: _____

Installation Date: _____

Serial number information can be found on the Serial Number Label included in the Information Packet found in the cleaner carton.

This information will be helpful for any future inquiries or questions about belt cleaner replacement parts, specifications or troubleshooting.

Table of Contents

Section 1 - Important Information	4
1.1 General Introduction.....	4
1.2 User Benefits	4
1.3 Service Option.....	4
Section 2 - Safety Considerations and Precautions	5
2.1 Stationary Conveyors.....	5
2.2 Operating Conveyors.....	5
2.3 ATEX Safety Info.....	6
Section 3 - Pre-Installation Checks and Options.....	7
3.1 Checklist.....	7
3.2 Optional Installation Accessories.....	8
Section 4 - Installation Instructions.....	9
4.1 MHS HD ATEX - SST XD Tensioner	9
4.2 MHS HD ATEX - SST XD Push-up Tensioning.....	12
Section 5 - Pre-Operation Checklist and Testing.....	13
5.1 Pre-Op Checklist	13
5.2 Test Run the Conveyor	13
Section 6 - Maintenance.....	14
6.1 New Installation Inspection	14
6.2 Routine Visual Inspection.....	14
6.3 Routine Physical Inspection	14
6.4 Maintenance Log.....	15
6.5 Cleaner Maintenance Checklist.....	16
Section 7 - Troubleshooting	17
Section 8 - Specs and CAD Drawings.....	18
8.1 Specs and Guidelines	18
8.2 CAD Drawing - MHS HD - SST XD Tensioner.....	19
Section 9 - Replacement Parts	20
9.1 Replacement Parts List	20
Section 10 - Other Flexco Conveyor Products.....	21

Section 1 - Important Information

1.1 General Introduction

We at Flexco are very pleased that you have selected an MHS HD ATEX Secondary Cleaner for your conveyor system.

This manual will help you to understand the operation of this product and assist you in making it work up to its maximum efficiency over its lifetime of service.

It is essential for safe and efficient operation that the information and guidelines presented be properly understood and implemented. This manual will provide safety precautions, installation instructions, maintenance procedures and troubleshooting tips.

If, however, you have any questions or problems that are not covered, please contact your field representative or our Customer Service Department.

Visit www.flexco.com for other Flexco locations and products.

Please read this manual thoroughly and pass it on to any others who will be directly responsible for installation, operation and maintenance of this cleaner. While we have tried to make the installation and service tasks as easy and simple as possible, **it does however require correct installation and regular inspections and adjustments to maintain top working condition.**

1.2 User Benefits

Correct installation and regular maintenance will provide the following benefits for your operation:

- Reduced conveyor downtime
- Reduced man-hour labor
- Lower maintenance budget costs
- Increased service life for the belt cleaner and other conveyor components

1.3 Service Option

The MHS HD ATEX Secondary Cleaner is designed to be easily installed and serviced by your on-site personnel. However, if you would prefer complete turn-key factory service, please contact your local Flexco Field Representative.

Section 2 - Safety Considerations and Precautions

Before installing and operating the MHS HD ATEX Secondary Cleaner, it is important to review and understand the following safety information.

There are set-up, maintenance and operational activities involving both **stationary** and **operating** conveyors. Each case has a safety protocol.

2.1 Stationary Conveyors

The following activities are performed on stationary conveyors:

- Installation
- Blade replacement
- Repairs
- Tension adjustments
- Cleaning

DANGER

It is imperative that OSHA/MSHA Lockout/Tagout (LOTO) regulations, 29 CFR 1910.147, be followed before undertaking the preceding activities. Failure to use LOTO exposes workers to uncontrolled behavior of the belt cleaner caused by movement of the conveyor belt. Severe injury or death can result.

Before working:

- Lockout/Tagout the conveyor power source.
- Disengage any takeups.
- Clear the conveyor belt or clamp securely in place.

WARNING

Use Personal Protective Equipment (PPE):

- Safety eyewear
- Hardhats
- Safety footwear

Close quarters, springs and heavy components create a worksite that compromises a worker's eyes, feet and skull. PPE must be worn to control the foreseeable hazards associated with conveyor belt cleaners. Serious injuries can be avoided.

2.2 Operating Conveyors

There are two routine tasks that must be performed while the conveyor is running:

- Inspection of the cleaning performance.
- Dynamic troubleshooting.

DANGER

Every belt cleaner is an in-running nip hazard. Never touch or prod an operating cleaner. Cleaner hazards cause instantaneous amputation and entrapment.

WARNING

Belt cleaners can become projectile hazards. Stay as far from the cleaner as practical and use safety eyewear and headgear. Missiles can inflict serious injury.

WARNING

Never adjust anything on an operating cleaner. Unforseeable belt projections and tears can catch on cleaners and cause violent movements of the cleaner structure. Flailing hardware can cause serious injury or death.

Section 2 - Safety Considerations and Precautions

2.3 ATEX Safety Info

The ATEX version of the MHS HD Cleaner has been designed to conform to the safety standards per Directive 94/9/EC.

Marking example:

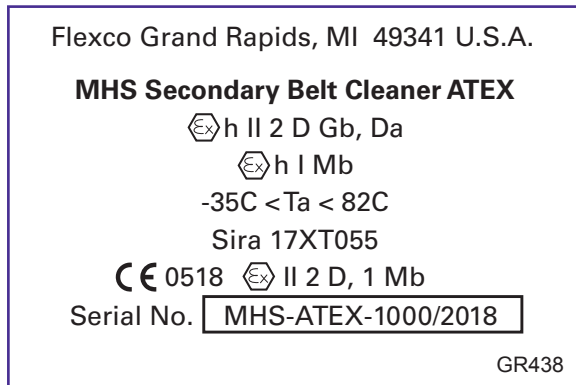

Safety Considerations:

- Welding and grinding that takes place during the installation or maintenance of the MHS should only be done when explosive atmospheres are not present. Follow mine/industrial site safety regulations when welding or grinding.
- Attach the MHS HD Secondary Cleaner to a grounded conveyor structure. The product itself is made of conductive materials. To ensure a connection, attach grounding wire between scraper tips and conveyor structure. Use the provided lock washers to mount cleaner to the structure or weld mounting plate to structure. Testing to ensure the grounded connection is advised in applications with potential for static buildup on the cleaner.
- Limit belt speed to 3.5 m/s maximum and remove tension on cleaner if belt will be run empty for more than 2 hours.

Section 3 - Pre-installation Checks and Options

3.1 Checklist

- Check that the cleaner size is correct for the beltline width.
- Check the belt cleaner carton and make sure all the parts are included.
- Review the “Tools Needed” list on the top of the installation instructions.
- Check the conveyor site:
 - Will the cleaner be installed on a chute?
 - Is the install on an open head pulley requiring mounting structure?
(see 3.2 - Optional Installation Accessories)

Section 3 - Pre-installation Checks and Options

3.2 Optional Installation Accessories

Versatile, adjustable brackets that can be mounted on the conveyor structure so the MHS HD ATEX Secondary Cleaner can be quickly and easily bolted into place. Pole extenders are also available for wide, non-standard conveyor structures.

ATEX Safety Note: when using these optional accessories with the MHS in a potentially explosive atmosphere, verify that the cleaner maintains grounding to the conveyor structure.

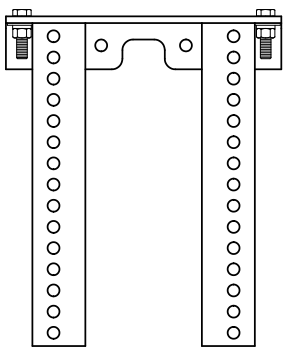

SST Standard Mounting Bracket Kit (for SST XD Tensioner)
(Item Code: 76071)

- For most secondary cleaner installs.
- 325 x 388 mm (13 x 15-1/2")

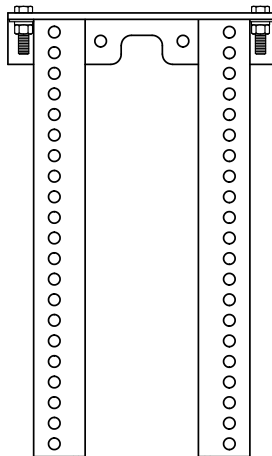

SST Long Mounting Bracket Kit (for SST XD Tensioner)
(Item Code: 76072)

- For installations that require extra length legs.
- 325 x 538 mm (13 x 21-1/2")

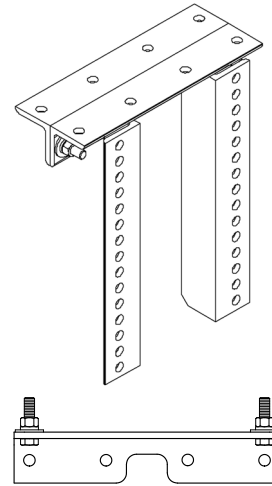

SST Optional Top Angle Kit (for SST XD Tensioner)
(Item Code: 76073)

- Used with both standard and long mounting bracket kits for additional mounting options.
- 325 mm (13")

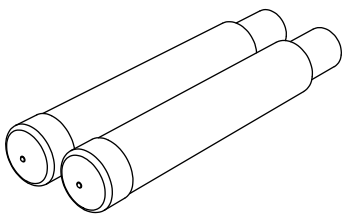

Pole Extender Kit (incl. 2 pole extenders)
(Item Code: 76024)

- For cleaner sizes 1800 mm (72") and larger
- Provides 750 mm (30") of extended pole length

Optional Mounting Kits (includes 2 brackets/bars)

DESCRIPTION	ORDERING NUMBER	ITEM CODE	WT. KG
Standard Mounting Bracket Kit *	SSTSMB	76071	15.6
Long Mounting Bracket Kit *	SSTLMB	76072	19.7
Optional Top Angle Kit *	SSTOTA	76073	4.8
Pole Extender Kit	MAPEK	76024	9.9

*Hardware Included
Lead time: 1 working day

Section 4 - Installation Instructions

4.1 MHS HD ATEX - SST XD Tensioner

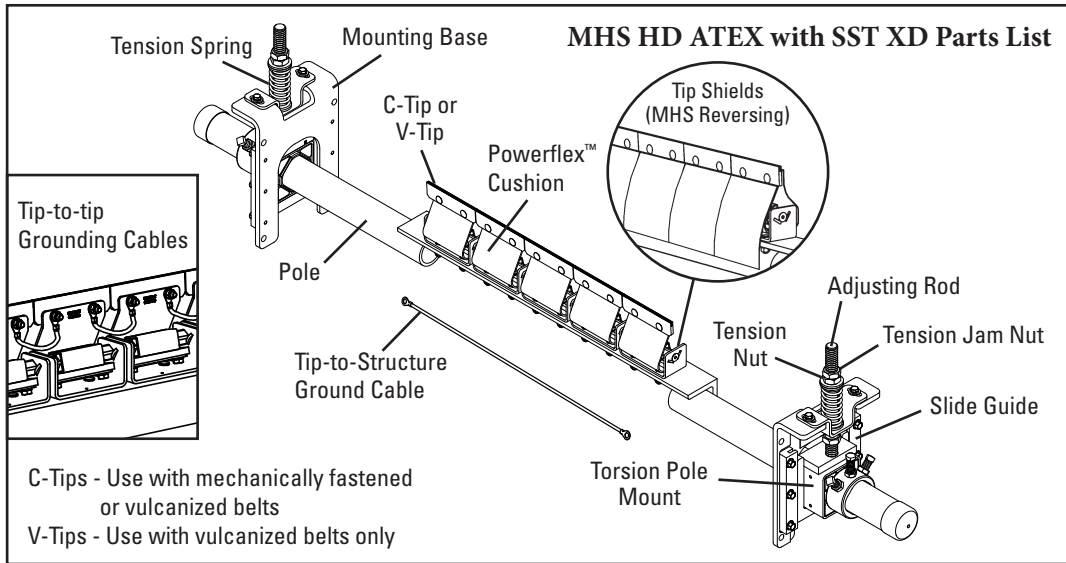

Physically lock out and tag the conveyor at the power source before you begin cleaner installation.

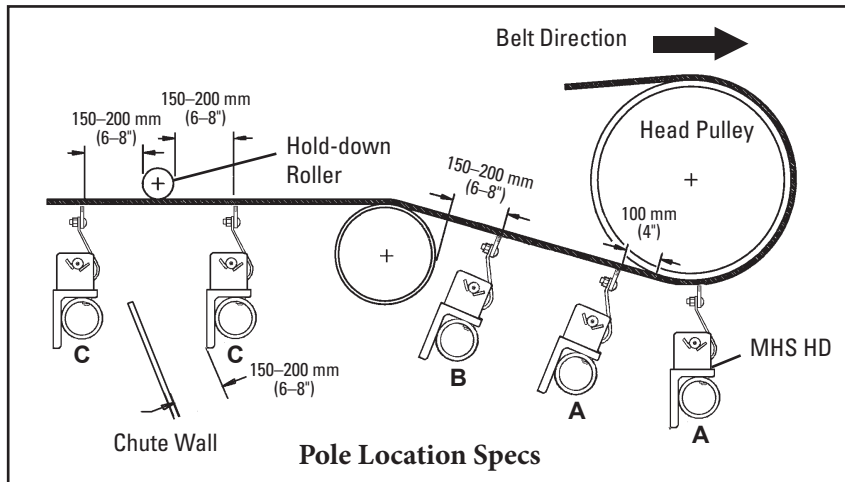

- Tools Needed:**
- 14 mm (9/16") Wrench
 - 19 mm (3/4") Wrench
 - 22 mm (7/8") Wrench
 - 35 mm (1-3/8") Wrench
 - OR Large Adjustable/ Crescent Wrenches (x2)
 - Clamps (x2)
 - Torch (as needed)
 - Welder (as needed)
 - Tape Measure
 - Level
 - Marking Pen or Soapstone

Section 4 - Installation Instructions

4.1 MHS HD ATEX - SST XD Tensioner

1. **Install the spring tensioner mounting bases.** (For push-up tensioning refer to additional instructions on Page 12.) Clamp the mounting base into position so the top flange of the base is aligned with the belt line (Fig. 1a). Bolt or weld the mounting base in place. Locate and install the mounting base on the opposite side. Adjust the tension nuts on each side so the center of the torsion pole mount is below the belt line.

NOTE: For chute mounting, a belt location line must be drawn on the chute wall so the mounting base can be aligned with the belt (Fig. 1b). Cut access holes as needed (Fig. 1c).

2. **Install the pole.** Slide the pole into one torsion pole mount as far as needed and locate the other end into the opposite mount (Fig. 2a). If there is not enough space, remove one of the torsion pole mounts from the mounting base, slide the pole through the mounting base and reassemble (Fig. 2b).

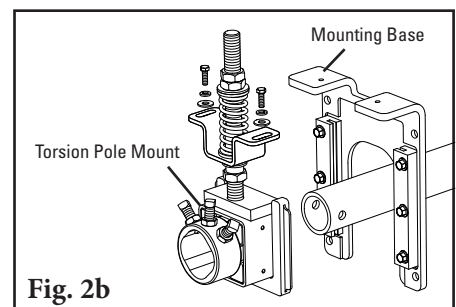
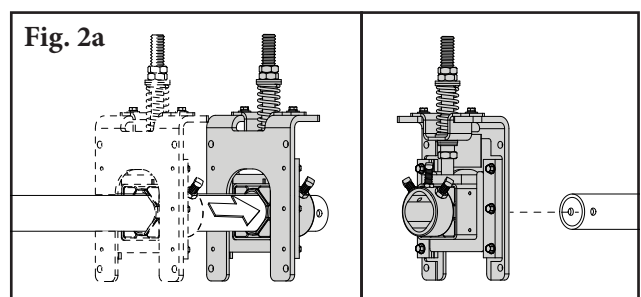
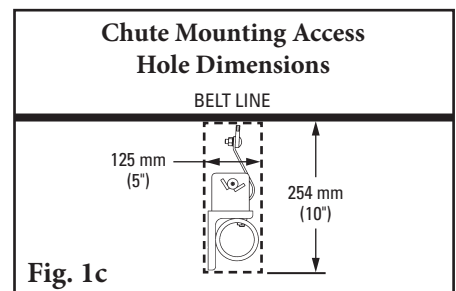
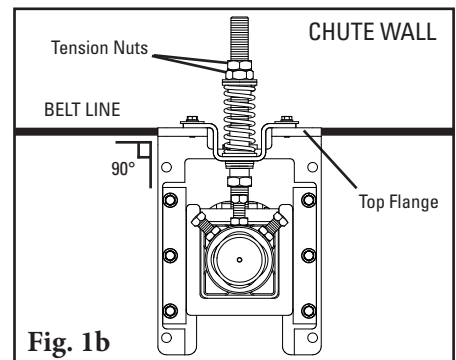
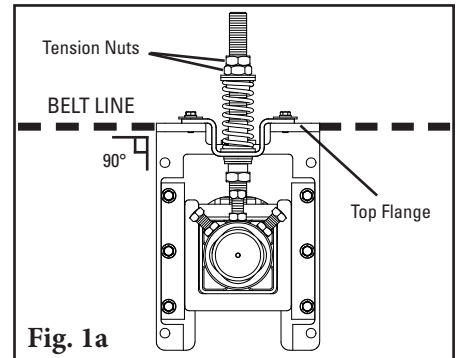

Section 4 - Installation Instructions

4.1 MHS HD ATEX - SST XD Tensioner

3. Set the blade angle. Center the pole/blades on the belt.

For MHS Standard: Rotate the pole until the tips align with the white “MHS Standard” side of the tip setup gauge provided (Fig. 3a).

For MHS Reversing: Rotate the pole until the tips are perpendicular to the belt, using the black “MHS Reversing” side of the tip setup gauge provided (Fig. 3b).

Tighten the three locking bolts on each torsion pole mount to lock the pole in place. Best practice is to first tighten the middle bolt before tightening the outer bolts to ensure everything is secure (Fig. 3c). There should be no blade-to-belt contact while locking the pole in the correct position. If contact occurs, double check the dimension from Step 1.

4. Attach the ground cable between the tip and structure and pull to the structure. (Fig. 4)

5. Set the blade tension. Loosen the top tension jam nuts on both sides. Turn the tension nuts until the correct spring compression is reached. Spring compression is determined by spring length. See the chart at right for the correct spring length for your belt width.

6. Set adjusting rod sleeve. After setting the blade tension, screw the adjusting rod sleeve into the UHMW bushing until 38 mm (1-1/2") is showing (Fig. 5). Tighten the adjusting rod sleeve jam nut.

7. Test run the cleaner and inspect the cleaning performance. If vibration occurs or more cleaning efficiency is desired, increase the blade tension by making 3 mm (1/8") compression adjustments on the tension springs.

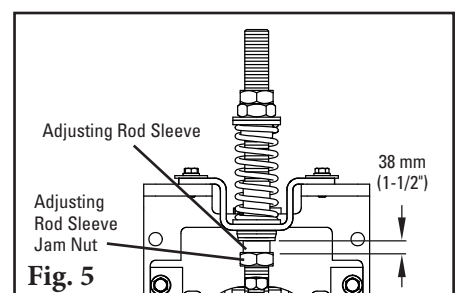
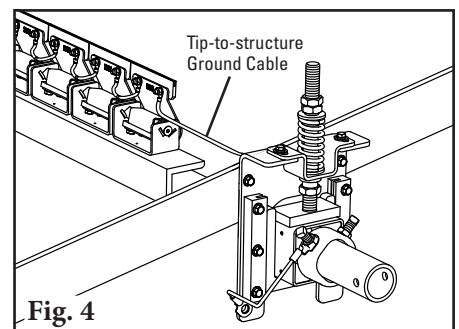
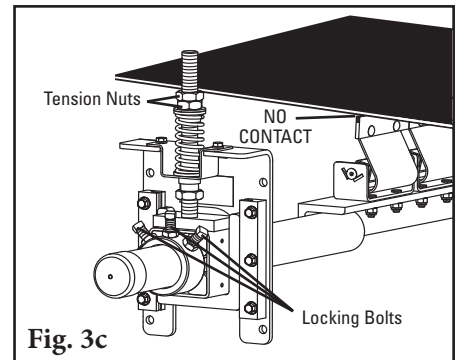
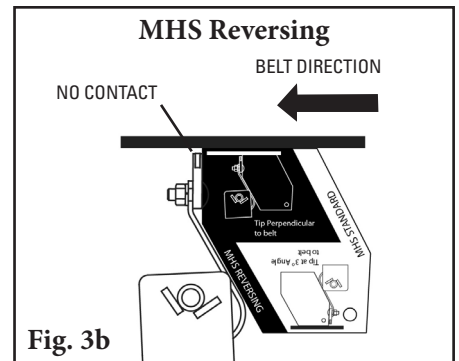
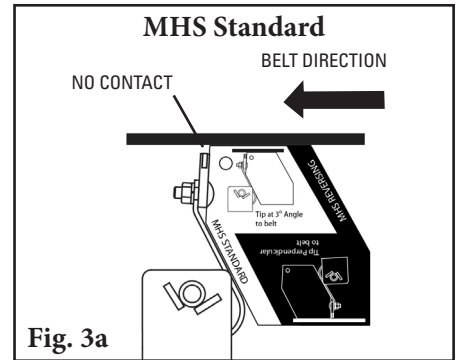

SST XD Spring Length Chart

Belt Width		White Springs		Silver Springs		Black Springs		Gold Springs	
mm	in.	mm	in.	mm	in.	mm	in.	mm	in.
450	18	86	3 3/8	102	4	N/A	N/A	N/A	N/A
600	24	79	3 1/8	98	3 7/8	N/A	N/A	N/A	N/A
750	30	73	2 7/8	95	3 3/4	N/A	N/A	N/A	N/A
900	36	N/A	N/A	95	3 3/4	98	3 7/8	N/A	N/A
1050	42	N/A	N/A	92	3 5/8	95	3 3/4	N/A	N/A
1200	48	N/A	N/A	89	3 1/2	92	3 5/8	N/A	N/A
1350	54	N/A	N/A	86	3 3/8	92	3 5/8	95	3 3/4
1500	60	N/A	N/A	83	3 1/4	89	3 1/2	95	3 3/4
1800	72	N/A	N/A	N/A	N/A	86	3 3/8	92	3 5/8
2100	84	N/A	N/A	N/A	N/A	79	3 1/8	89	3 1/2
2400	96	N/A	N/A	N/A	N/A	N/A	N/A	86	3 3/8

Shading indicates preferred spring option.

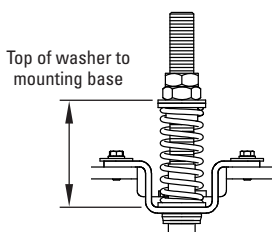

Section 4 - Installation Instructions

4.2 MHS HD ATEX - SST XD Push-Up Tensioning

- 1. Reconfigure the standard pull-up tensioner to the push-up style.** Remove the 3 tension nuts, the flat washer, 2 bushings, the spring, the sleeve and the hat bracket; reassemble (Fig. 1) with 2 tension nuts, the flat washer, 2 bushings, the spring and the hat bracket on the upper end of the adjusting rod. Add the 3rd tension nut to bottom of the adjusting rod, this will act as a lock for the metal sleeve.
- 2. Install the tensioner mounting bases.** Mount the bases to the structure or chute so that the tops of the base legs are 83 mm (3-1/4") below the belt (Fig. 1).
- 3. Install the cleaner pole and set the blade angle.** Follow the installation steps from the cleaner instructions on Page 10.

NOTE: be sure the lock bolts on the torsion pole mount have been securely tightened to lock the pole in place before moving to Step 4. Best practice is to first tighten the middle bolt before tightening the outer bolts to ensure everything is secure.

- 4. Set the blade tension.** Remove the bottom tension nut and washer from the adjusting rod. Turn the two upper tension nuts until the spring is compressed to the length shown on the Spring Length Chart below. Tighten the two tension nuts together to prevent loosening.
- 5. Replace the sleeve.** Position the sleeve over the adjusting rod and turn it until it is in the middle of the bushing. Replace the bottom tension nut and tighten until it locks the sleeve in place (Fig. 2).

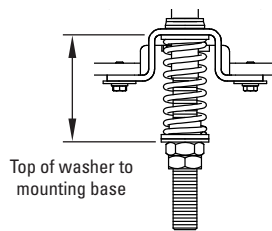
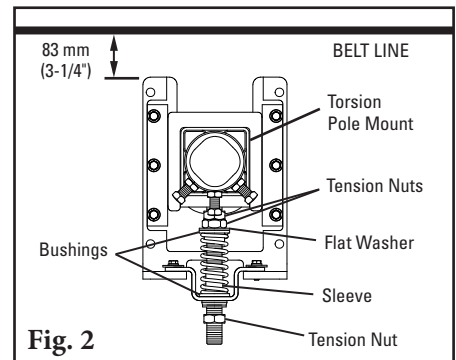
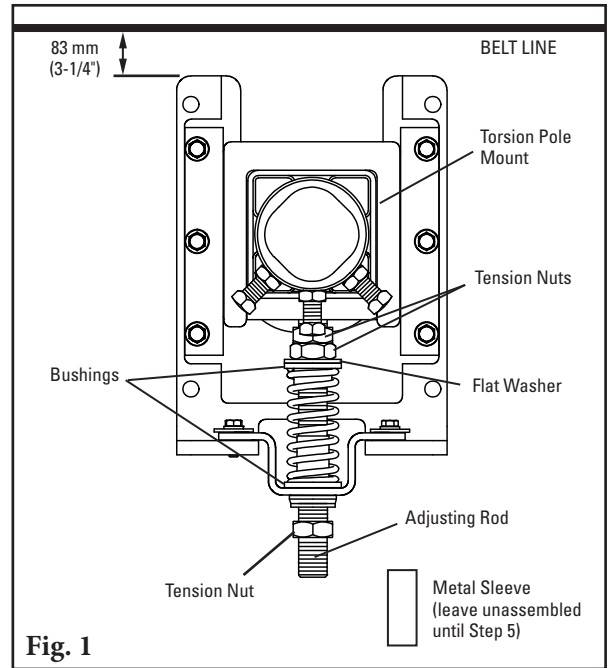

SST XD Spring Length Chart

Belt Width		White Springs		Silver Springs		Black Springs		Gold Springs	
mm	in.	mm	in.	mm	in.	mm	in.	mm	in.
450	18	86	3 3/8	102	4	N/A	N/A	N/A	N/A
600	24	79	3 1/8	98	3 7/8	N/A	N/A	N/A	N/A
750	30	73	2 7/8	95	3 3/4	N/A	N/A	N/A	N/A
900	36	N/A	N/A	95	3 3/4	98	3 7/8	N/A	N/A
1050	42	N/A	N/A	92	3 5/8	95	3 3/4	N/A	N/A
1200	48	N/A	N/A	89	3 1/2	92	3 5/8	N/A	N/A
1350	54	N/A	N/A	86	3 3/8	92	3 5/8	95	3 3/4
1500	60	N/A	N/A	83	3 1/4	89	3 1/2	95	3 3/4
1800	72	N/A	N/A	N/A	N/A	86	3 3/8	92	3 5/8
2100	84	N/A	N/A	N/A	N/A	79	3 1/8	89	3 1/2
2400	96	N/A	N/A	N/A	N/A	N/A	N/A	86	3 3/8

Shading indicates preferred spring option.

Section 5 - Pre-Operation Checklist and Testing

5.1 Pre-Op Checklist

- Recheck that all fasteners are tightened properly.
- Add pole caps.
- Apply all supplied labels to the cleaner.
- Check the blade location on the belt.
- Be sure that all installation materials and tools have been removed from the belt and the conveyor area.

5.2 Test Run the Conveyor

- Run the conveyor for at least 15 minutes and inspect the cleaning performance.
- Check the tensioner spring for recommended length (proper tensioning).
- Make adjustments as necessary.

NOTE: Observing the cleaner when it is running and performing properly will help to detect problems or when adjustments are needed later.

Section 6 - Maintenance

Flexco belt cleaners are designed to operate with minimum maintenance. However, to maintain superior performance some service is required. When the cleaner is installed a regular maintenance program should be set up. This program will ensure that the cleaner operates at optimal efficiency and problems can be identified and fixed before the cleaner stops working.

All safety procedures for inspection of equipment (stationary or operating) must be observed. The MHS HD ATEX Secondary Cleaner operates at the discharge end of the conveyor and is in direct contact with the moving belt. Only visual observations can be made while the belt is running. Service tasks can be done only with the conveyor stopped and by observing the correct lockout/tagout procedures.

6.1 New Installation Inspection

After the new cleaner has run for a few days a visual inspection should be made to ensure the cleaner is performing properly. Make adjustments as needed.

6.2 Routine Visual Inspection (every 2-4 weeks)

A visual inspection of the cleaner and belt should look for:

- If spring length is the correct length for optimal tensioning
- If belt looks clean or if there are areas that are dirty
- If blade is worn out and needs to be replaced
- If there is damage to the blade or other cleaner components
- If fugitive material is built up on cleaner or in the transfer area
- If there is cover damage to the belt
- If there is vibration or bouncing of the cleaner on the belt
- If a snub pulley is used, a check should be made for material buildup on the pulley
- Significant signs of carryback
- If any grounding cables are missing or detached

If any of the above conditions exist, a determination should be made on when the conveyor can be stopped for cleaner maintenance.

6.3 Routine Physical Inspection (every 6-8 weeks)

When the conveyor is not in operation and properly locked and tagged out, a physical inspection of the cleaner to perform the following tasks:

- Clean material buildup off of the cleaner blade and pole
- Closely inspect the blade for wear and any damage. Replace if needed.
- Ensure full blade to belt contact
- Inspect the cleaner pole for damage
- Inspect all fasteners for tightness and wear. Tighten or replace as needed.
- Replace any worn or damaged components
- Check the tension of the cleaner blade to the belt. Adjust the tension if necessary using the chart on the cleaner or the one on page 11 or 12.
- When maintenance tasks are completed, test run the conveyor to ensure the cleaner is performing properly

Section 6 - Maintenance

6.4 Maintenance Log

Conveyor Name/No. _____

Date: _____ Work done by: _____ Service Quote #: _____

Activity: _____

Date: _____ Work done by: _____ Service Quote #: _____

Activity: _____

Date: _____ Work done by: _____ Service Quote #: _____

Activity: _____

Date: _____ Work done by: _____ Service Quote #: _____

Activity: _____

Date: _____ Work done by: _____ Service Quote #: _____

Activity: _____

Date: _____ Work done by: _____ Service Quote #: _____

Activity: _____

Date: _____ Work done by: _____ Service Quote #: _____

Activity: _____

Date: _____ Work done by: _____ Service Quote #: _____

Activity: _____

Date: _____ Work done by: _____ Service Quote #: _____

Activity: _____



Section 6 - Maintenance

6.5 Cleaner Maintenance Checklist

Site: _____ Inspected by: _____ Date: _____

Belt Cleaner: _____ Serial Number: _____

Beltline Information:

Beltline Number: _____ Belt Condition: _____

Belt Width: 450mm (18") 600mm (24") 750mm (30") 900mm (36") 1050mm (42") 1200mm (48") 1350mm (54") 1500mm (60") 1800mm (72") 2100mm (84") 2400mm (96")

Belt Speed: _____ fpm Belt Thickness: _____

Belt Splice: _____ Condition of Splice: _____ Number of Splices: _____ Skived Unskived

Material conveyed: _____

Days per week run: _____ Hours per day run: _____

Blade Life:

Date blade installed: _____ Date blade inspected: _____ Estimated blade life: _____

Is blade making complete contact with belt? Yes No

Blade wear: Left _____ Middle _____ Right _____

Blade condition: Good Grooved Smiled Not contacting belt Damaged

Measurement of spring: Required _____ Currently _____

Was Cleaner Adjusted: Yes No

Pole Condition: Good Bent Worn

Lagging: Side Lag Ceramic Rubber Other None

Condition of lagging: Good Bad Other _____

Cleaner's Overall Performance: (Rate the following 1 - 5, 1= very poor - 5 = very good)

Appearance: : Comments: _____

Location: : Comments: _____

Maintenance: : Comments: _____

Performance: : Comments: _____

Other comments: _____

Section 7 - Troubleshooting

Problem	Possible Cause	Possible Solutions
Vibration	Cleaner secure bolts not set	Ensure all locking nuts are tight (Loctite)
	Cleaner not set up correctly	Ensure cleaner set up properly (check tip angle with gauge) MHS Standard 1°-3° into belt; MHS Reversing and SAT XD perpendicular
	Belt tension too high	Ensure cleaner can conform to belt, or replace with alternate Flexco secondary cleaner
	Belt flap	Introduce hold-down roller to flatten belt
	Cleaner over-tensioned	Ensure cleaner is correctly tensioned
	Cleaner under-tensioned	Ensure cleaner is correctly tensioned
	Nylon bearing worn out or missing	Replace nylon bearing
Material buildup on cleaner	Cleaner not set up correctly	Ensure cleaner set up properly (1°-3° into belt)
	Buildup on chute	Ensure cleaner is not located too close to back of chute, allowing buildup
	Cleaner being overburdened	Introduce Flexco precleaner
	Excessive sticky material	Frequently clean unit of buildup
Damaged belt cover	Cleaner over-tensioned	Ensure cleaner is correctly tensioned
	Cleaner blade damage	Check blade for wear, damage and chips, replace where necessary
	Attack angle not correct	Ensure cleaner set up properly (check tip angle with gauge) MHS Standard 1°-3° into belt; MHS Reversing and SAT XD perpendicular
	Material buildup in chute	Frequently clean unit of buildup
Cleaner not conforming to belt	Cleaner not set up correctly	Ensure cleaner set up properly (check tip angle with gauge) MHS Standard 1°-3° into belt; MHS Reversing and SAT XD perpendicular
	Belt tension too high	Ensure cleaner can conform to belt (introduce hold-down roller), or replace with alternate Flexco secondary cleaner
	Belt flap	Introduce hold-down roller to flatten belt
	Cleaner cannot conform	Ensure cleaner can conform to belt (introduce hold-down roller), or replace with alternate Flexco secondary cleaner
Material passing cleaner	Cleaner not set up correctly	Ensure cleaner set up properly (check tip angle with gauge) MHS Standard 1°-3° into belt; MHS Reversing and SAT XD perpendicular
	Cleaner tension too low	Ensure cleaner is correctly tensioned
	Cleaner blade worn/damaged	Check blade for wear, damage and chips, replace where necessary
	Cleaner being overburdened	Introduce Flexco precleaner
	Belt flap	Introduce hold-down roller to flatten belt
	Belt worn or grooved	Introduce water spray pole
	Cleaner cannot conform	Ensure cleaner can conform to belt (introduce hold-down roller), or replace with alternate Flexco secondary cleaner
	Blade in backwards	Install blade correctly and set correct tension
Damage to mechanical fastener	Incorrect cleaner blade selection	Change blade type to accommodate fastener style (UC or UF)
	Belt not skived correctly	Spot and redo splice correctly, lowering the profile flush or below belt surface
	Blade angle incorrect	Reset with gauge
Missing material in belt center only	Cupped Belt	Install hold-down roller and reset blade angle with gauge
	Cleaner blade worn/damaged	Check blade for wear, damage and chips, replace where necessary
Missing material on outer edges only	Cupped Belt	Install hold-down roller and reset blade angle with gauge
	Cleaner blade worn/damaged	Check blade for wear, damage and chips, replace where necessary
Tensioners binding	Tensioners not aligned properly	Adjust mounting bases until tensioners travel without binding
	Material buildup on tensioner guide pole	Clean off guide pole

Section 8 - Specs and CAD Drawings

8.1 Specs and Guidelines

Pole Length Specifications*

CLEANER SIZE		BLADE WIDTH		POLE LENGTH		MAXIMUM CONVEYOR SPAN	
mm	in.	mm	in.	mm	in.	mm	in.
450	18	450	18	1800	72	1550	62
600	24	600	24	1950	78	1700	68
750	30	750	30	2100	84	1850	74
900	36	900	36	2250	90	2000	80
1050	42	1050	42	2400	96	2150	86
1200	48	1200	48	2550	102	2300	92
1350	54	1350	54	2700	108	2450	98
1500	60	1500	60	2850	114	2600	104
1800	72	1800	72	3150	126	2900	116
2100	84	2100	84	3450	138	3200	128
2400	96	2400	96	3750	150	3500	140

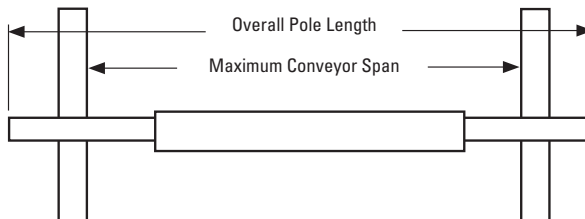

*For special extra long pole length requirements a Pole Extender Kit (#76024) is available that provides 750mm (30") of extended pole length. See Page 8.

Pole Diameter - 73mm (2-7/8")

Clearance Guidelines for Installation

HORIZONTAL CLEARANCE REQUIRED		VERTICAL CLEARANCE REQUIRED	
mm	in.	mm	in.
100	4	238	10

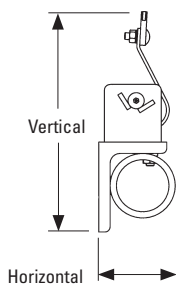

SST XD Spring Length Chart

Belt Width		White Springs		Silver Springs		Black Springs		Gold Springs	
mm	in.	mm	in.	mm	in.	mm	in.	mm	in.
450	18	86	3 3/8	102	4	N/A	N/A	N/A	N/A
600	24	79	3 1/8	98	3 7/8	N/A	N/A	N/A	N/A
750	30	73	2 7/8	95	3 3/4	N/A	N/A	N/A	N/A
900	36	N/A	N/A	95	3 3/4	98	3 7/8	N/A	N/A
1050	42	N/A	N/A	92	3 5/8	95	3 3/4	N/A	N/A
1200	48	N/A	N/A	89	3 1/2	92	3 5/8	N/A	N/A
1350	54	N/A	N/A	86	3 3/8	92	3 5/8	95	3 3/4
1500	60	N/A	N/A	83	3 1/4	89	3 1/2	95	3 3/4
1800	72	N/A	N/A	N/A	N/A	86	3 3/8	92	3 5/8
2100	84	N/A	N/A	N/A	N/A	79	3 1/8	89	3 1/2
2400	96	N/A	N/A	N/A	N/A	N/A	N/A	86	3 3/8

Shading indicates preferred spring option.

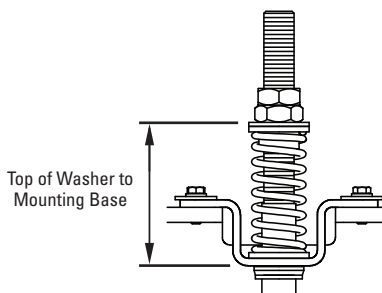

Specifications:

- Maximum Belt Speed6 m/s (1200 FPM)
- Temperature Rating-35 to 82°C (-30 to 180°F)
- Usable Blade Wear Length.....9 mm (3/8")
- Blade MaterialsC-Tip: Impact Resistant Tungsten Carbide (works with mechanical fasteners)
V-Tip: Long Life Tungsten Carbide (for vulcanized belts only)
- Available for Belt Widths450 to 2400 mm (18 to 96") Other sizes available upon request.
- CEMA Cleaner RatingClass 5

Section 8 - Specs and CAD Drawings

8.2 CAD Drawing - MHS HD ATEX - SST XD Tensioner

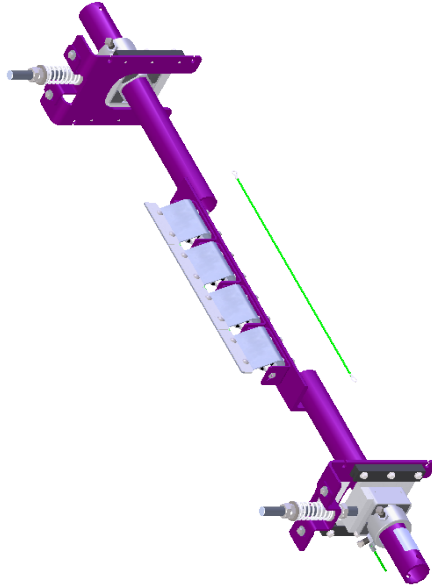

SPECIFICATIONS			MHS C CLEANER		ITEM NUMBER ① MHS POLE	
BELT WIDTH 'A' (in)	POLE LENGTH 'B' (mm)	# OF TIPS	ORDER NUMBER	ITEM CODE	ORDER NUMBER	ITEM CODE
18	450	3	MHS-450A	90475	MHSP-18	76178
24	600	4	MHS-600A	90476	MHSP-24	75918
30	700	5	MHS-750A	90477	MHSP-30	76636
36	900	6	MHS-900A	90478	MHSP-36	75843
42	1050	7	MHS-1050A	90479	MHSP-42	75921
48	1200	8	MHS-1200A	90480	MHSP-48	75922
54	1350	9	MHS-1400A	90481	MHSP-54	75923
60	1500	10	MHS-1500A	90482	MHSP-60	75924
72	1800	12	MHS-1800A	90483	MHSP-72	75925
84	2100	14	MHS-2100A	90484	MHSP-84	76814
96	2400	16	MHS-2400A	90485	MHSP-96	79052
108	2700	18	MHS-2700A	90486	MHSP-108	90330
120	3000	20	MHS-3000A	90487	MHSP-120	90331

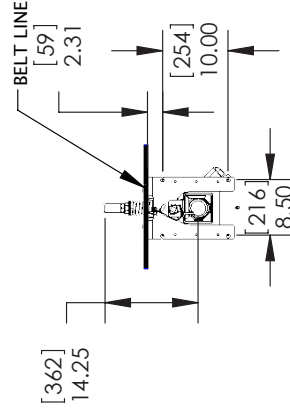
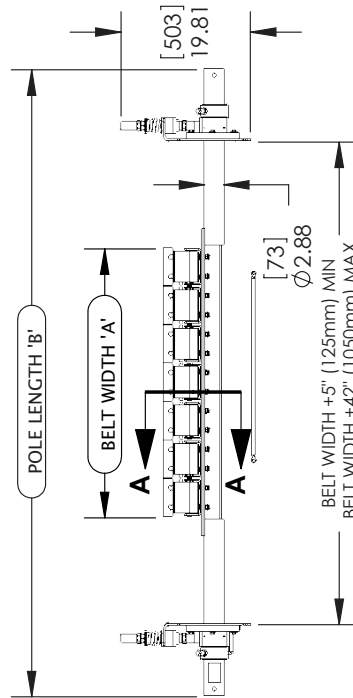

SECTION A-A

Section 9 - Replacement Parts

9.1 Replacement Parts List

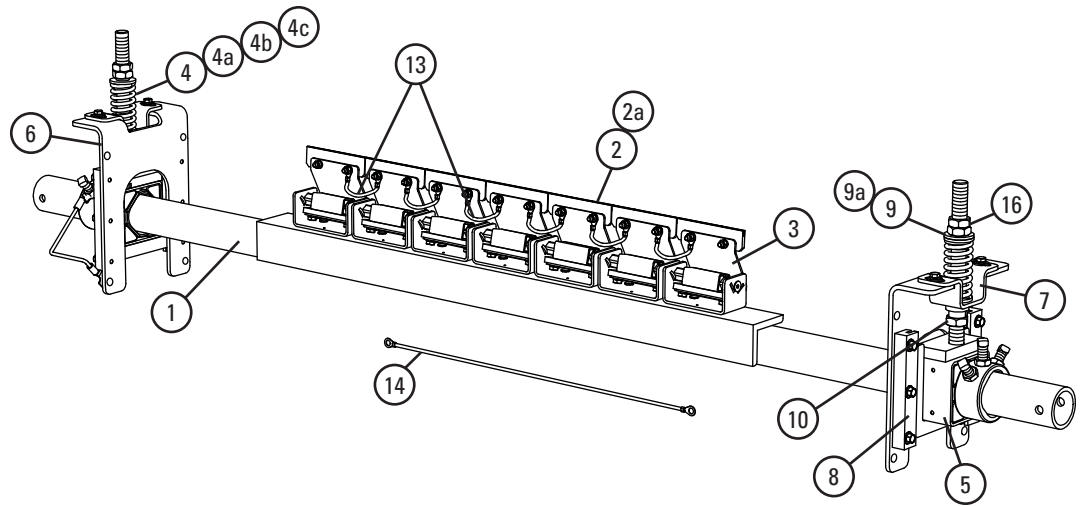

Replacement Parts

REF	DESCRIPTION	ORDERING NUMBER	ITEM CODE	WT. KG
1	450mm (18") Pole	MHSP-18	76178	21.0
	600mm (24") Pole	MHSP-24	75918	23.4
	750mm (30") Pole	MHSP-30	75919	25.9
	900mm (36") Pole	MHSP-36	75920	28.5
	1050mm (42") Pole	MHSP-42	75921	31.0
	1200mm (48") Pole	MHSP-48	75922	33.5
	1350mm (54") Pole	MHSP-54	75923	36.0
	1500mm (60") Pole	MHSP-60	75924	38.5
	1800mm (72") Pole	MHSP-72	75925	43.6
	2100mm (84") Pole	MHSP-84	76814	50.8
2400mm (96") Pole	MHSP-96	79052	58.1	
2	C-Tip*	ICT6	74535	0.3
2a	V-Tip* (for vulcanized belts only)	RSA150	73628	0.6
3	PowerFlex™ Cushion* (complete)	PFC	75927	1.9
4	Tension Spring - White (1 ea.) for belts 450–750mm (18–30")	STS-W	75846	0.2
4a	Tension Spring - Silver (1 ea.) for belts 900–1200mm (36–48")	STS-S	75843	0.4
4b	Tension Spring - Black (1 ea.) for belts 1350–2100mm (54–84")	STS-B	75844	0.5
4c	Tension Spring - Gold (1 ea.) for belts 2400mm (96")	STS-G	78142	0.6
5	HD Torsion Pole Mount* (1 ea.) (See 9 & 9a for bushings) (incl. HD adjusting rod, nuts & sleeve)	SSTHDPM	77868	6.8
6	SST XD Mounting Base Kit* (incl. 1 ea. mounting base, top hat bracket, bottom bushing & 2 slide guides)	SSTXDMK	91412	4.6
7	SST Hat Bracket (pair)	SSTHB	79582	1.4
8	Slide Guide Kit* (incl. 2 slide guides)	STGK2	77867	0.5
9	SST Bushing Kit - White/Silver (incl. 2 bushings)	SSTBK-W	76636	0.1
9a	SST Bushing Kit - Black/Gold (incl. 2 bushings)	SSTBK-B	76637	0.1
10	SST Lower Bushing Kit (pair)	SSTLBK	79493	0.1
11	P Stainless Steel Shield	PSSS	74773	0.2
12	PowerFlex™ Reverse Shield	PFRS	76622	0.2
13	Tip-to-Tip Grounding Wire	TT-GWK	90788	0.1
14	Tip-to-Structure Grounding Wire	TS-GWK	90789	0.1
15	Polyurethane Cushion Shield	UPFCC	79320	0.1
16	Jam Nut Kit SST	JNK-C	79893	0.1
–	SST XD Tensioner* - White (incl. 2 ea. items 4, 5, 6, 9)	SSTXD-W	91408	27.5
–	SST XD Tensioner* - Silver (incl. 2 ea. items 4a, 5, 6, 9)	SSTXD-S	91409	27.8
–	SST XD Tensioner* - Black (incl. 2 ea. items 4b, 5, 6, 9a)	SSTXD-B	91410	28.1
–	SST XD Tensioner* - Gold (incl. 2 ea. items 4c, 5, 6, 9a)	SSTXD-G	91411	28.4

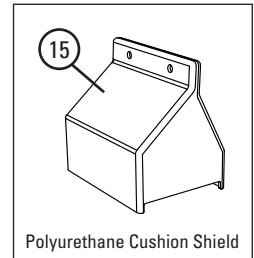
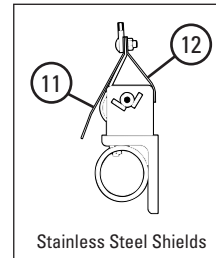

Spring Tensioner Selection Chart

CLEANER SIZE	91408 SSTXD-W	91409 SSTXD-S	91410 SSTXD-B	91411 SSTXD-G
MHS 450–750mm (18–30")	X			
MHS 900–1200mm (36–48")		X		
MHS 1350–2100mm (54–84")			X	
MHS 2400mm (96")				X

*Hardware Included

Lead time: 1 working day

U.S. Patent No. 6,823,983; 7,093,706

Section 10 - Other Flexco Conveyor Products

Flexco provides many conveyor products that help your conveyors to run more efficiently and safely. These components solve typical conveyor problems and improve productivity. Here is a quick overview on just a few of them:

MMP Precleaner

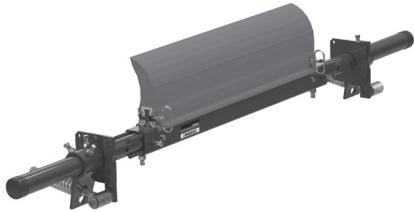

- Extra cleaning power right on the head pulley
- A 250 mm (10") TuffShear™ blade provides increased blade tension on the belt to peel off abrasive materials
- The unique Visual Tension Check™ ensures optimal blade tensioning and quick, accurate retensioning
- Easy to install and simple to service

DRX Impact Beds



- Exclusive Velocity Reduction Technology™ in order to better protect the belt
- Slide-Out Service™ gives direct access to all impact bars for change-out
- Impact bar supports for longer bar life
- 4 models to custom fit to the application

MDWS DryWipe Secondary Cleaner



- Wipes the belt dry as final cleaner in system
- Automatic blade tensioning to the belt
- Easy, visual blade tension check
- Simple, one-pin blade replacement

PT Max™ Belt Trainer



- Patented “pivot & tilt” design for superior training action
- Dual sensor rollers on each side to minimize belt damage
- Pivot point guaranteed not to freeze up
- Available for topside and return side belts

Flexco Specialty Belt Cleaners



- “Limited space” cleaners for tight conveyor applications
- High Temp cleaners for severe, high heat applications
- A rubber fingered cleaner for chevron and raised rib belts
- Multiple cleaner styles in stainless steel for corrosive applications

Belt Plows



- A belt cleaner for the tail pulley
- Exclusive blade design quickly spirals debris off the belt
- Economical and easy to service
- Available in vee or diagonal models

Visit www.flexco.com for other Flexco locations and products, or to find an authorised distributor.

©2021 Flexible Steel Lacing Company. 02-28-25. X6038

