

MDWS Heavy-Duty Belt Cleaner

The Final Step in Belt Cleaning

Belt cleaners regularly do a good job of taking off carryback materials. However, after your last cleaner, there is still water on the belt that can still cause a big mess along the beltline. The MDWS Belt Cleaner is designed to be the last cleaner in a cleaning system, to ensure the belt is left completely dry.

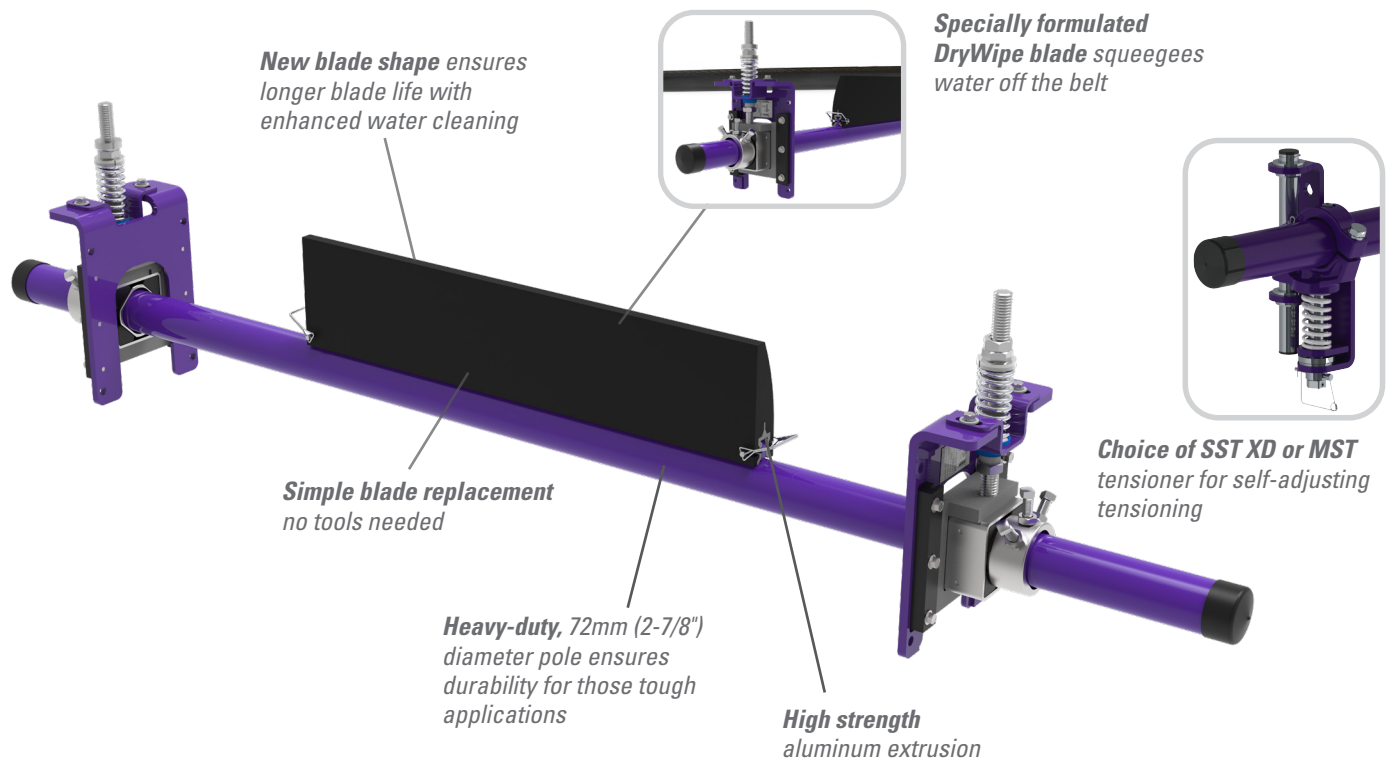

Features and Benefits

- **Long wear life.** Blade has 113mm (4-1/2") of usable urethane.
- **Low maintenance.** Occasionally check for blade wear and measure springs for proper tensioning.
- **Works with mechanical fasteners.** The polyurethane blade easily glides over the mechanical splices and the spring tensioners dampen any impact, allowing the splices to pass without damage to the blade or the splice and with minimal cleaning disruption.
- **Streamlined design.** The MDWS has minimal horizontal surfaces for carryback to build up on. Carryback buildup often renders other secondary cleaners ineffective.
- **Complete cleaning system.** When teamed with a Flexco Primary Cleaner and one or more secondary cleaners depending upon the application, the MDWS is the unbeatable final cleaner in a cleaning system that delivers unmatched cleaning performance and efficiency.
- **Made for mining conveyors.** The MDWS comes standard with an extra-long pole (belt width plus 1500mm (60") for cleaners up to 1500mm (60") and belt width plus 1350mm (54") for cleaners over 1500mm (60")), so it can be used on most mining conveyors. It is available for belt widths from 600 to 2400mm (24 to 96").

MDWS

Heavy-Duty Secondary Belt Cleaner

Specifications and Guidelines

Maximum Belt Speed

5 m/s (1000 FPM)

Temperature Rating

-35 to 82°C (-30 to 180°F)

Blade Height

185mm (7-1/4")

Usable Blade Wear Length

113mm (4-1/2")

Blade Material

Urethane 59 durometer (softer to squeegee water off)

Available for Belt Widths

600 to 2100mm (24 to 84")

Pole Length Cleaner size +1370mm

Minimum Conveyor Span Cleaner size +150mm

Maximum Conveyor Span Cleaner size +1050mm

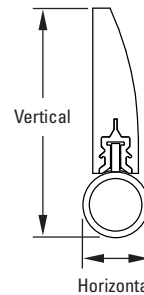
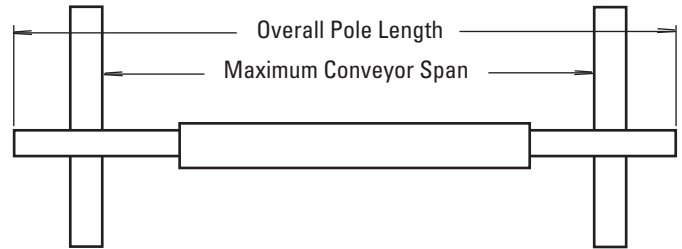

Horizontal Clearance Required
100mm (4")

Vertical Clearance Required
250mm (10")

Ordering Information

MDWS Mild Steel Secondary Belt Cleaner with SST XD Tensioner

BELT WIDTH		ORDERING NUMBER	ITEM CODE	WT. KG
mm	in			
600	24	MDWS-24	75868	52.2
750	30	MDWS-30	75869	55.7
900	36	MDWS-36	75870	58.0
1050	42	MDWS-42	75871	62.7
1200	48	MDWS-48	75872	66.6
1350	54	MDWS-54	75873	70.1
1500	60	MDWS-60	75874	73.6
1800	72	MDWS-72	75875	80.6
2100	84	MDWS-84	76806	87.6
2400	96	MDWS-96	79063	94.7

MDWS Mild Steel Secondary Belt Cleaner with MST Tensioner

BELT WIDTH		ORDERING NUMBER	ITEM CODE	WT. KG
mm	in			
600	24	MDWS-MST-600	67559	52.2
750	30	MDWS-MST-750	67560	55.7
900	36	MDWS-MST-900	67561	58.0
1050	42	MDWS-MST-1050	67562	62.7
1200	48	MDWS-MST-1200	67563	66.6
1350	54	MDWS-MST-1350	67564	70.1
1500	60	MDWS-MST-1500	67565	73.6
1800	72	MDWS-MST-1800	67566	80.6
2100	84	MDWS-MST-2100	67567	87.6
2400	96	MDWS-MST-2400	67568	94.7

MDWS Stainless Steel Secondary Belt Cleaner with SST XD Tensioner

BELT WIDTH		ORDERING NUMBER	ITEM CODE	WT. KG
mm	in			
600	24	MDWS-600-S/S	67466	52.5
750	30	MDWS-750-S/S	67467	56.0
900	36	MDWS-900-S/S	67468	58.3
1050	42	MDWS-1050-S/S	67469	63.0
1200	48	MDWS-1200-S/S	67470	67.0
1350	54	MDWS-1350-S/S	67471	70.5
1500	60	MDWS-1500-S/S	67472	74.0
1800	72	MDWS-1800-S/S	67473	81.1
2100	84	MDWS-2100-S/S	67474	88.1
2400	96	MDWS-2400-S/S	67475	95.3

MDWS Stainless Steel Secondary Belt Cleaner with MST Tensioner

BELT WIDTH		ORDERING NUMBER	ITEM CODE	WT. KG
mm	in			
600	24	MDWS-MST-600-S/S	67476	42.5
750	30	MDWS-MST-750-S/S	67477	46.0
900	36	MDWS-MST-900-S/S	67478	48.3
1050	42	MDWS-MST-1050-S/S	67479	53.0
1200	48	MDWS-MST-1200-S/S	67480	57.0
1350	54	MDWS-MST-1350-S/S	67481	60.5
1500	60	MDWS-MST-1500-S/S	67482	64.0
1800	72	MDWS-MST-1800-S/S	67483	71.1
2100	84	MDWS-MST-2100-S/S	67484	78.1
2400	96	MDWS-MST-2400-S/S	67485	85.3