

CBS Continuous Blade Secondary Cleaner

Installation, Operation and Maintenance Manual

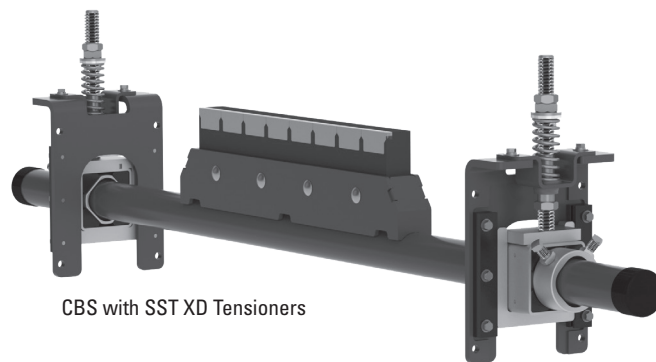

CBS with SST XD Tensioners

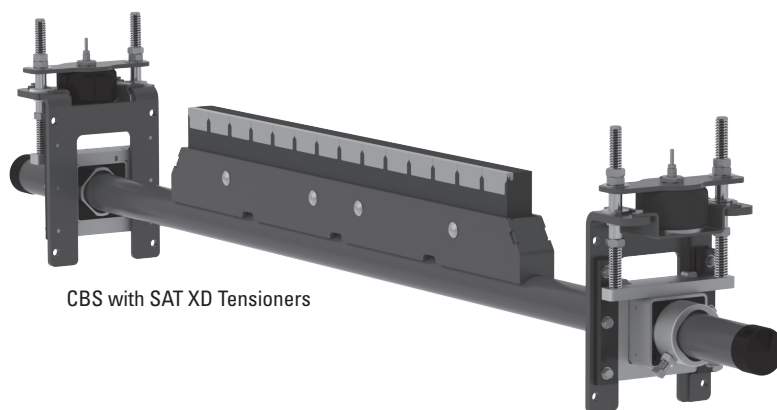

CBS with SAT XD Tensioners

CBS Secondary Cleaner

Serial Number: _____
Purchase Date: _____
Purchased From: _____
Installation Date: _____

Serial number information can be found on the Serial Number Label included in the Information Packet found in the cleaner carton.

This information will be helpful for any future inquiries or questions about belt cleaner replacement parts, specifications or troubleshooting.

Table of Contents

Section 1 - Important Information	4
1.1 General Introduction.....	4
1.2 User Benefits	4
1.3 Service Option.....	4
Section 2 - Safety Considerations and Precautions	5
2.1 Stationary Conveyors.....	5
2.2 Operating Conveyors.....	5
Section 3 - Pre-Installation Checks and Options.....	6
3.1 Checklist.....	6
3.2 Optional Installation Accessories.....	7
Section 4 - Installation Instructions.....	8
4.1 CBS - SST XD	8
4.2 CBS - SST XD - Push-up Tensioning.....	11
4.3 CBS - SAT XD.....	12
4.4 CBS - SAT XD - Push-up Tensioning.....	15
Section 5 - Pre-Operation Checklist and Testing.....	16
5.1 Pre-Op Checklist.....	16
5.2 Test Run the Conveyor	16
Section 6 - Maintenance.....	17
6.1 New Installation Inspection	17
6.2 Routine Visual Inspection.....	17
6.3 Routine Physical Inspection	17
6.4 Maintenance Log.....	18
6.5 Cleaner Maintenance Checklist.....	19
Section 7 - Troubleshooting	20
Section 8 - Specs and CAD Drawings.....	21
8.1 Specs and Guidelines	21
8.2 CAD Drawing - CBS Flat - SST XD.....	22
8.3 CAD Drawing - CBS Curved - SST XD	23
8.4 CAD Drawing - CBS Flat - SAT XD	24
8.5 CAD Drawing - CBS Curved - SAT XD.....	25
Section 9 - Replacement Parts	26
9.1 Replacement Parts List - Blades & Poles	26
9.2 Replacement Parts List - SST XD/SAT XD Tensioners	27
Section 10 - Other Flexco Conveyor Products.....	28

Section 1 - Important Information

1.1 General Introduction

We at Flexco are very pleased that you have selected a CBS Continuous Blade Secondary Cleaner for your conveyor system.

This manual will help you to understand the operation of this product and assist you in making it work up to its maximum efficiency over its lifetime of service.

It is essential for safe and efficient operation that the information and guidelines presented be properly understood and implemented. This manual will provide safety precautions, installation instructions, maintenance procedures and troubleshooting tips.

If, however, you have any questions or problems that are not covered, please contact your field representative or our Customer Service Department.

Visit www.flexco.com for other Flexco locations and products.

Please read this manual thoroughly and pass it on to any others who will be directly responsible for installation, operation and maintenance of this cleaner. While we have tried to make the installation and service tasks as easy and simple as possible, **it does however require correct installation and regular inspections and adjustments to maintain top working condition.**

1.2 User Benefits

Correct installation and regular maintenance will provide the following benefits for your operation:

- Reduced conveyor downtime
- Reduced man-hour labor
- Lower maintenance budget costs
- Increased service life for the belt cleaner and other conveyor components

1.3 Service Option

The CBS Continuous Blade Secondary Cleaner is designed to be easily installed and serviced by your on-site personnel. However, if you would prefer complete turn-key factory service, please contact your local Flexco Field Representative.

Section 2 - Safety Considerations and Precautions

Before installing and operating the CBS Continuous Blade Secondary Cleaner, it is important to review and understand the following safety information.

There are set-up, maintenance and operational activities involving both **stationary** and **operating** conveyors. Each case has a safety protocol.

2.1 Stationary Conveyors

The following activities are performed on stationary conveyors:

- Installation
- Blade replacement
- Repairs
- Tension adjustments
- Cleaning

DANGER

It is imperative that OSHA/MSHA Lockout/Tagout (LOTO) regulations, 29 CFR 1910.147, be followed before undertaking the preceding activities. Failure to use LOTO exposes workers to uncontrolled behavior of the belt cleaner caused by movement of the conveyor belt. Severe injury or death can result.

Before working:

- Lockout/Tagout the conveyor power source.
- Disengage any takeups.
- Clear the conveyor belt or clamp securely in place.

WARNING

Use Personal Protective Equipment (PPE):

- Safety eyewear
- Hardhats
- Safety footwear

Close quarters, springs and heavy components create a worksite that compromises a worker's eyes, feet and skull. PPE must be worn to control the foreseeable hazards associated with conveyor belt cleaners. Serious injuries can be avoided.

2.2 Operating Conveyors

There are two routine tasks that must be performed while the conveyor is running:

- Inspection of the cleaning performance.
- Dynamic troubleshooting.

DANGER

Every belt cleaner is an in-running nip hazard. Never touch or prod an operating cleaner. Cleaner hazards cause instantaneous amputation and entrapment.

WARNING

Belt cleaners can become projectile hazards. Stay as far from the cleaner as practical and use safety eyewear and headgear. Missiles can inflict serious injury.

WARNING

Never adjust anything on an operating cleaner. Unforseeable belt projections and tears can catch on cleaners and cause violent movements of the cleaner structure. Flailing hardware can cause serious injury or death.

Section 3 - Pre-installation Checks and Options

3.1 Checklist

- Check that the cleaner size is correct for the beltline width.
- Check the belt cleaner carton and make sure all the parts are included.
- Review the “Tools Needed” list on the top of the installation instructions.
- Check the conveyor site:
 - Will the cleaner be installed on a chute?
 - Is the install on an open head pulley requiring mounting structure?
(see 3.2 - Optional Installation Accessories)

Section 3 - Pre-installation Checks and Options

3.2 Optional Installation Accessories

Versatile, adjustable brackets that can be mounted on the conveyor structure so the CBS Continuous Blade Secondary Cleaner can be quickly and easily bolted into place. Pole extenders are also available for wide, non-standard conveyor structures.

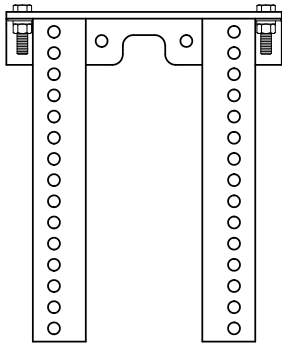

SST Standard Mounting Bracket Kit (for SST XD Tensioner)
(Item Code: 76071)

- For most secondary cleaner installs.
- 325 x 388 mm (13 x 15-1/2")

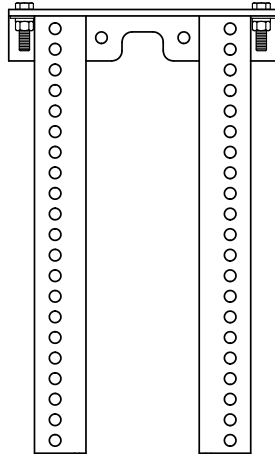

SST Long Mounting Bracket Kit (for SST XD Tensioner)
(Item Code: 76072)

- For installations that require extra length legs.
- 325 x 538 mm (13 x 21-1/2")

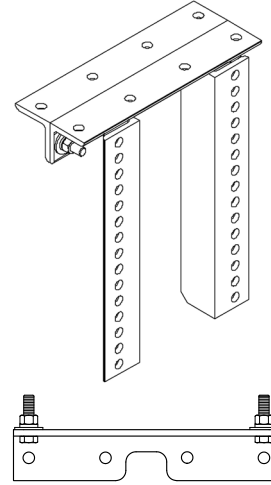

SST Optional Top Angle Kit (for SST XD Tensioner)
(Item Code: 76073)

- Used with both standard and long mounting bracket kits for additional mounting options.
- 325 mm (13")

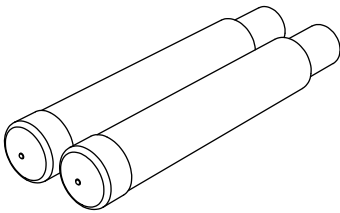

Pole Extender Kit (incl. 2 pole extenders)
(Item Code: 76024)

- For cleaner sizes 1800 mm (72") and larger
- Provides 750 mm (30") of extended pole length

Optional Mounting Kits (includes 2 brackets/bars)

DESCRIPTION	ORDERING NUMBER	ITEM CODE	WT. KG
Standard Mounting Bracket Kit *	SSTSMB	76071	15.6
Long Mounting Bracket Kit *	SSTLMB	76072	19.7
Optional Top Angle Kit *	SSTOTA	76073	4.8
Pole Extender Kit	MAPEK	76024	9.9

*Hardware Included
Lead time: 1 working day

Section 4 - Installation Instructions

4.1 CBS - SST XD Tensioner

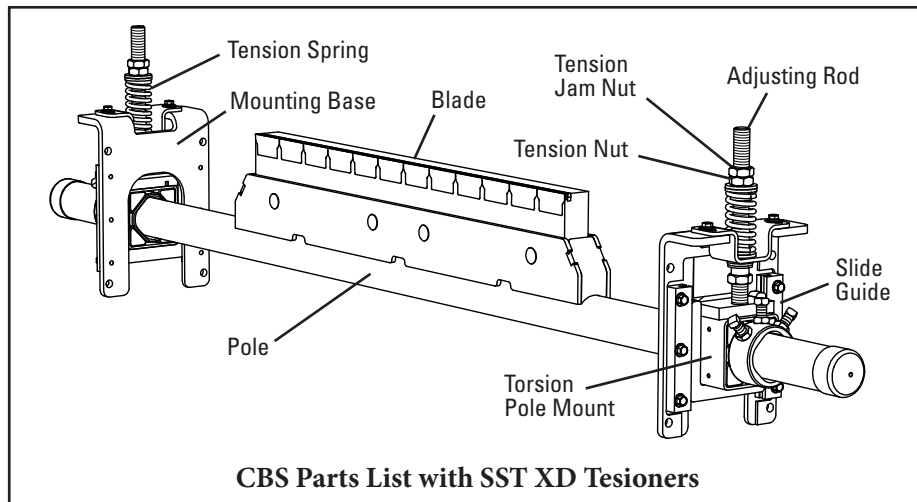

Physically lock out and tag the conveyor at the power source before you begin cleaner installation.

Tools Needed:

- 14 mm (9/16") Wrench
- 19 mm (3/4") Wrench
- 22 mm (7/8") Wrench
- 35 mm (1-3/8") Wrench
- OR Large Adjustable/
Crescent Wrenches (x2)
- Clamps (x2)
- Torch (as needed)
- Welder (as needed)
- Tape Measure
- Level
- Marking Pen or Soapstone

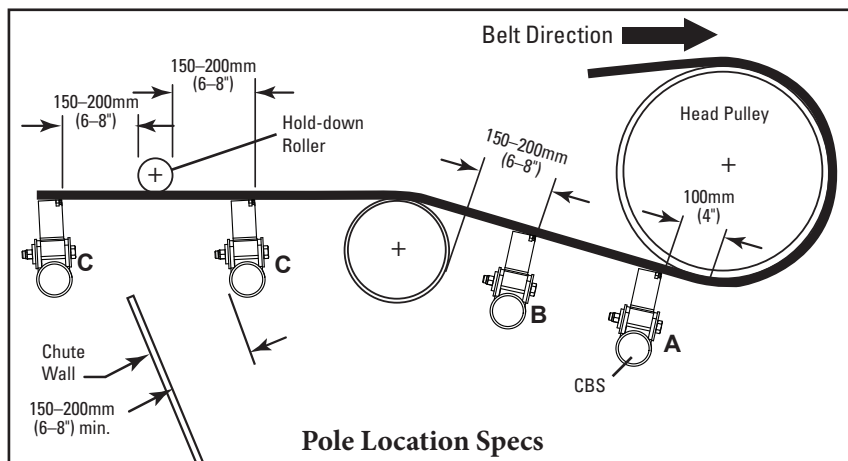

Section 4 - Installation Instructions

4.1 CBS - SST XD Tensioner

1. **Install the spring tensioner mounting bases.** (For push-up tensioning refer to additional instructions on page 11.) Clamp one mounting base into position so the top flange of the base is aligned with the belt line (Fig. 1a). Bolt or weld the mounting base in place. Locate and install the mounting base on the opposite side.

NOTE: For chute mounting, a belt location line must be drawn on the chute wall so the mounting base can be aligned with the belt (Fig. 1b). Cut access holes as needed (Fig. 1c).

2. **Install the pole.** Slide the pole into one torsion pole mount as far as needed and locate the other end into the opposite mount (Fig. 2a). If there is not enough space, remove one of the torsion pole mounts from the mounting base, slide the pole through the mounting base and reassemble (Fig. 2b).

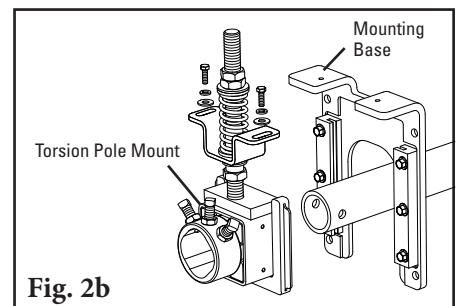
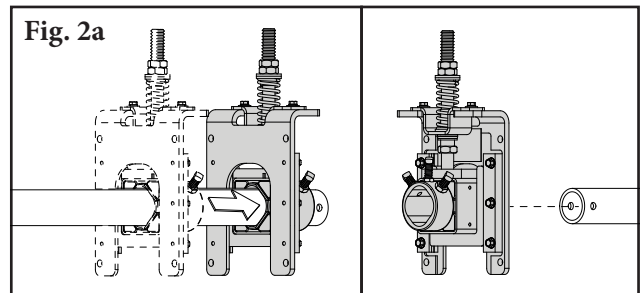
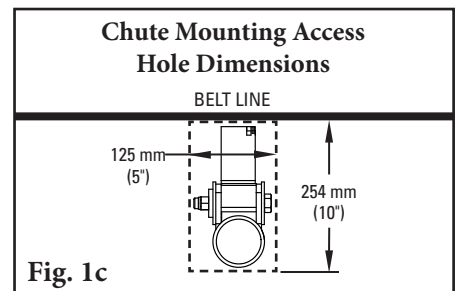
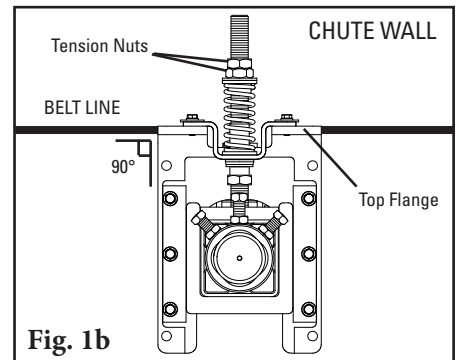
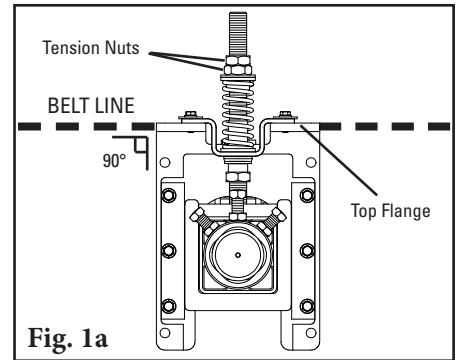

Section 4 - Installation Instructions

4.1 CBS - SST XD Tensioner

- Set the blade angle.** Center the pole/blades on the belt. Rotate the pole until the blade lays back 5° using the setup gauge provided (Fig. 3a). Tighten the three locking bolts on each torsion pole mount to lock the pole in place. Best practice is to first tighten the middle bolt before tightening the outer bolts to ensure everything is secure (Fig. 3b). There should be no blade-to-belt contact while locking the pole in the correct position. If contact occurs, double-check the dimension from Step 1.

NOTE: For optimal cleaning performance, it is recommended that mechanical fasteners on the belt be skived.

- Set the blade tension.** Loosen the top tension jam nuts on both sides. Turn the tension nuts until the correct spring compression is reached, determined by spring length. See the chart for the correct spring length for your belt width.
- Set adjusting rod sleeve.** After setting the blade tension, screw the adjusting rod sleeve(s) into the UHMW bushing until 38 mm (1-1/2") is showing (Fig. 4). Tighten the adjusting rod sleeve jam nut.
- Test run the cleaner and inspect the cleaning performance.** If vibration occurs or more cleaning efficiency is desired, increase the blade tension by making 3 mm (1/8") compression adjustments on the tension springs.

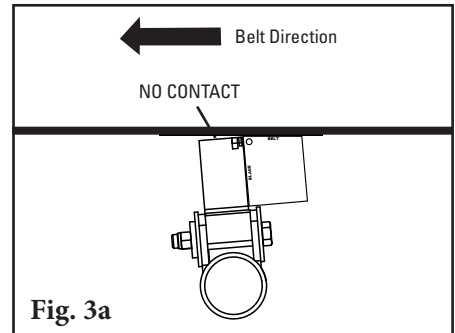

Fig. 3a

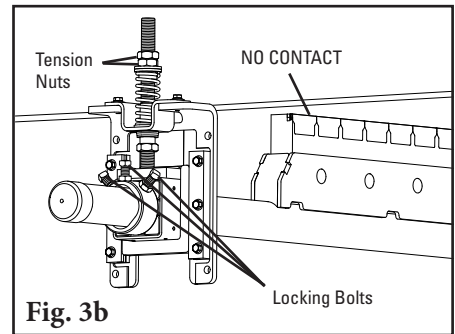

Fig. 3b

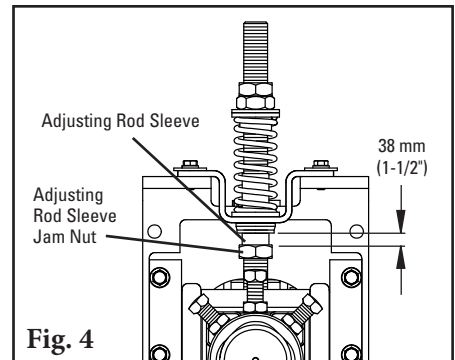
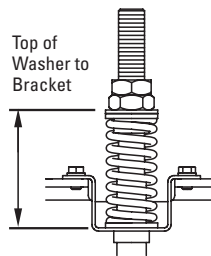

Fig. 4



SST XD Spring Length Chart

Belt Width		White Springs		Silver Springs		Black Springs		Gold Springs	
mm	in.	mm	in.	mm	in.	mm	in.	mm	in.
450	18	86	3 3/8	102	4	N/A	N/A	N/A	N/A
600	24	79	3 1/8	98	3 7/8	N/A	N/A	N/A	N/A
750	30	73	2 7/8	95	3 3/4	N/A	N/A	N/A	N/A
900	36	N/A	N/A	95	3 3/4	98	3 7/8	N/A	N/A
1050	42	N/A	N/A	92	3 5/8	95	3 3/4	N/A	N/A
1200	48	N/A	N/A	89	3 1/2	92	3 5/8	N/A	N/A
1350	54	N/A	N/A	86	3 3/8	92	3 5/8	95	3 3/4
1500	60	N/A	N/A	83	3 1/4	89	3 1/2	95	3 3/4
1800	72	N/A	N/A	N/A	N/A	86	3 3/8	92	3 5/8
2100	84	N/A	N/A	N/A	N/A	79	3 1/8	89	3 1/2
2400	96	N/A	N/A	N/A	N/A	N/A	N/A	86	3 3/8

Shading indicates preferred spring option.

Section 4 - Installation Instructions

4.2 CBS - SST XD - Push-up Tensioning

- 1. Reconfigure the standard pull-up tensioner to the push-up style.** Remove the 3 tension nuts, flat washer, 2 bushings, spring, sleeve and hat bracket; reassemble (Fig. 1) with 2 tension nuts, flat washer, 2 bushings, spring and hat bracket on upper end of adjusting rod. Add the washer (from instruction packet) and third tension nut to bottom of adjusting rod.
- 2. Install the tensioner mounting bases.** Mount the bases to the structure or chute so that the tops of the base legs are 38 mm (1-1/2") below the belt (Fig. 2).
- 3. Install the cleaner pole and set the blade angle.** Follow the installation steps from the cleaner instructions on page 10.

NOTE: Be sure the lock bolts on the torsion pole mount have been securely tightened to lock the pole in place before moving to Step 4.

- 4. Set the blade tension.** First, remove the bottom tension nut and washer from the adjusting rod. Next, turn the two upper tension nuts until the spring is compressed to the length shown on the Spring Length Chart below. Then tighten the two tension nuts together to prevent loosening.
- 5. Replace the sleeve.** Position the sleeve over the adjusting rod and turn it until it is in the middle of the bushing. Replace the bottom tension nut and tighten until it locks the sleeve in place (Fig. 2).

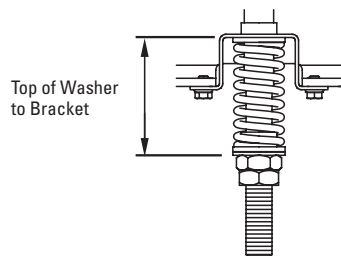
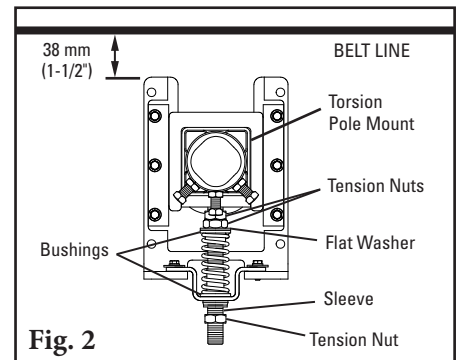
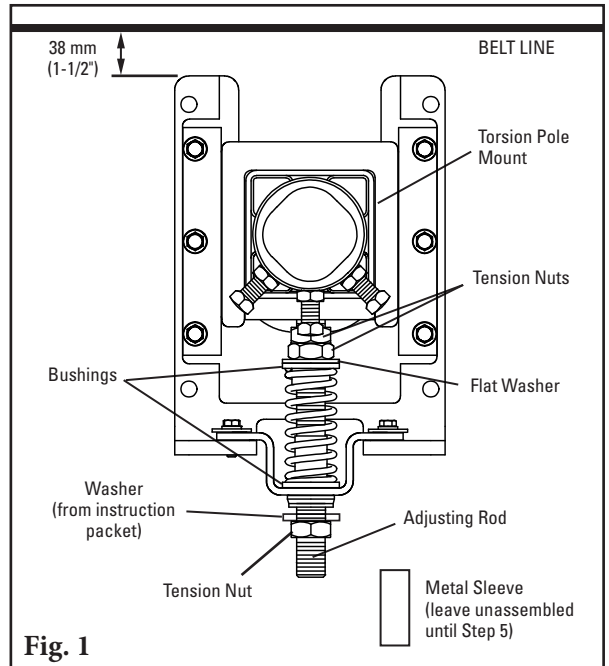

SST XD Spring Length Chart

Belt Width		White Springs		Silver Springs		Black Springs		Gold Springs	
mm	in.	mm	in.	mm	in.	mm	in.	mm	in.
450	18	86	3 3/8	102	4	N/A	N/A	N/A	N/A
600	24	79	3 1/8	98	3 7/8	N/A	N/A	N/A	N/A
750	30	73	2 7/8	95	3 3/4	N/A	N/A	N/A	N/A
900	36	N/A	N/A	95	3 3/4	98	3 7/8	N/A	N/A
1050	42	N/A	N/A	92	3 5/8	95	3 3/4	N/A	N/A
1200	48	N/A	N/A	89	3 1/2	92	3 5/8	N/A	N/A
1350	54	N/A	N/A	86	3 3/8	92	3 5/8	95	3 3/4
1500	60	N/A	N/A	83	3 1/4	89	3 1/2	95	3 3/4
1800	72	N/A	N/A	N/A	N/A	86	3 3/8	92	3 5/8
2100	84	N/A	N/A	N/A	N/A	79	3 1/8	89	3 1/2
2400	96	N/A	N/A	N/A	N/A	N/A	N/A	86	3 3/8

Shading indicates preferred spring option.

Section 4 - Installation Instructions

4.3 CBS - SAT XD Tensioner

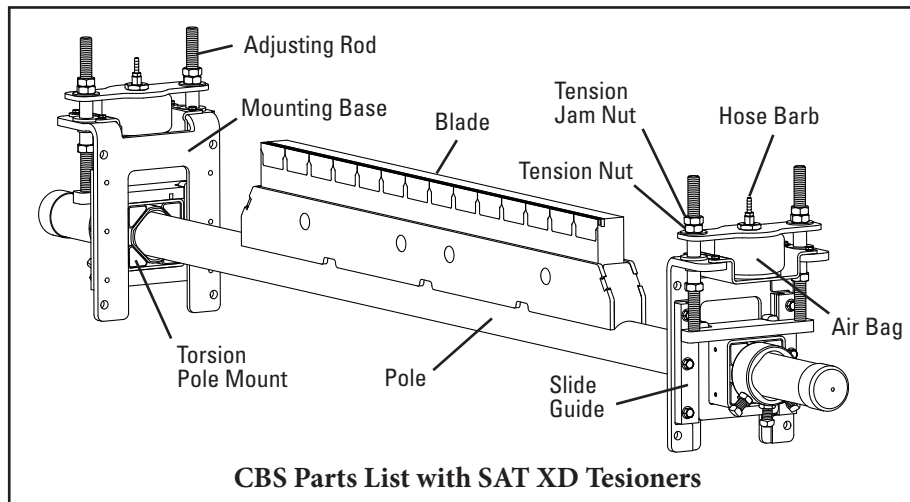

Physically lock out and tag the conveyor at the power source before you begin cleaner installation.

Tools Needed:

- 14 mm (9/16") Wrench
- 19 mm (3/4") Wrench
- 22 mm (7/8") Wrench
- 35 mm (1-3/8") Wrench
- OR Large Adjustable/
Crescent Wrenches (x2)
- Clamps (x2)
- Torch (as needed)
- Welder (as needed)
- Tape Measure
- Level
- Marking Pen or Soapstone

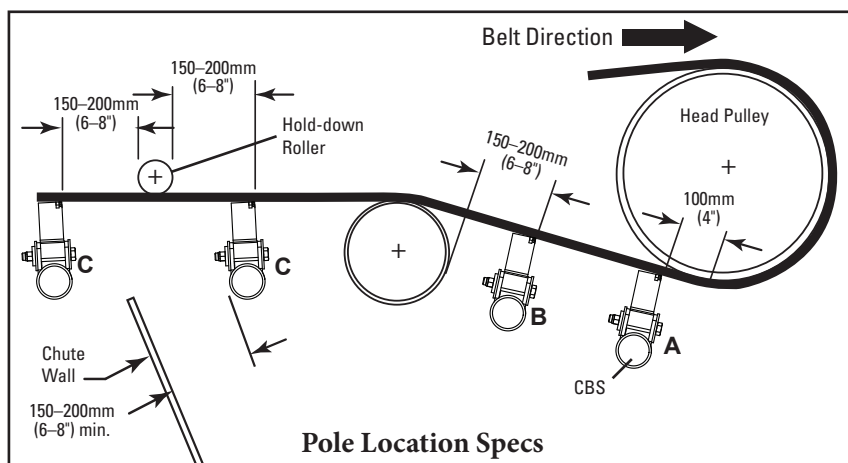

Section 4 - Installation Instructions

4.3 CBS - SAT XD Tensioner

1. **Install the air/water tensioner mounting bases.** (For push-up tensioning refer to additional instructions on page 15.) Clamp one mounting base into position so the top flange of the base is 12 mm (1/2") below the belt. Bolt or weld the mounting base in place and adjust threaded rod nuts 38 mm (1-1/2") down from top of threaded rods (Fig. 1a). Repeat on opposite side.

NOTE: For chute mounting, a belt location line must be drawn on the chute wall so the mounting base can be positioned 12 mm (1/2") below the belt (Fig. 1b). Cut access holes as needed (Fig. 1c).

2. **Install the pole.** Slide the pole into one torsion pole mount as far as needed and locate the other end into the opposite mount (Fig. 2). If there is not enough space, remove one of the torsion pole mounts from the mounting base, slide the pole through the mounting base and reassemble.

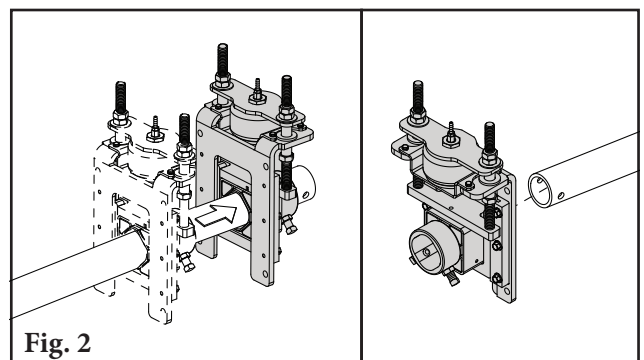
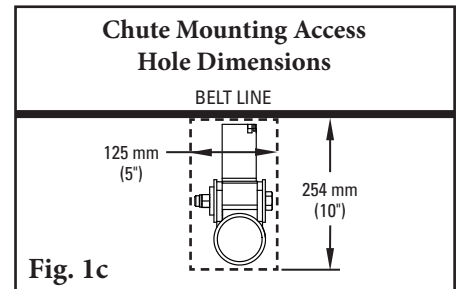
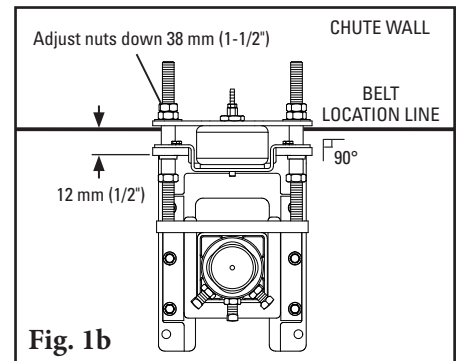
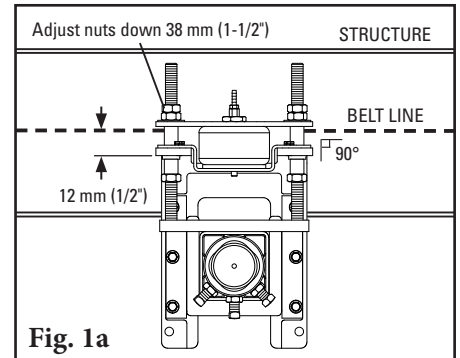

Section 4 - Installation Instructions

4.3 CBS - SAT XD Tensioner

- Set the blade angle.** Center the pole/blades on the belt. Rotate the pole until the blade lays back 5° using the setup gauge provided (Fig. 3a). Tighten the three locking bolts on each torsion pole mount to lock the pole in place. Best practice is to first tighten the middle bolt before tightening the outer bolts to ensure everything is secure (Fig. 3b). There should be no blade-to-belt contact while locking the pole in the correct position. If contact occurs, double-check the dimension from Step 1.

NOTE: For optimal cleaning performance, it is recommended that mechanical fasteners on the belt be skived.

- Set the blade tension.** With the parts supplied, attach a line to each air bag and run the lines to the outlet side of the control box (Fig. 4).

NOTE: Be sure lines are safely away from the belt. Connect the line from the inlet side of the box to the site's supply or air tank. Test the connections for leaks and set the pressure. The pressure may be reduced to suit the application. See the chart for the correct air pressure for your belt width.

- Set adjusting rod sleeve.** After setting the blade tension, screw the adjusting rod sleeve(s) into the UHMW bushing until 38 mm (1-1/2") is showing (Fig. 5). Tighten the adjusting rod sleeve jam nut.
- Test run the cleaner and inspect the cleaning performance.** If vibration occurs, increase blade layback by a small amount.

SAT XD Pressure Chart

Belt Width		Pressure	
mm	in.	kPa	psi
450	18	103	15
600	24	131	19
750	30	159	23
900	36	186	27
1050	42	214	31
1200	48	241	35
1350	54	269	39
1500	60	296	43
1800	72	352	51
2100	84	407	59
2400	96	462	67

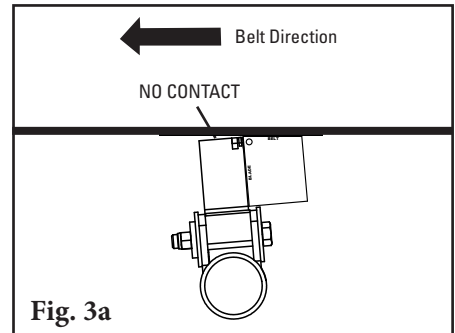

Fig. 3a

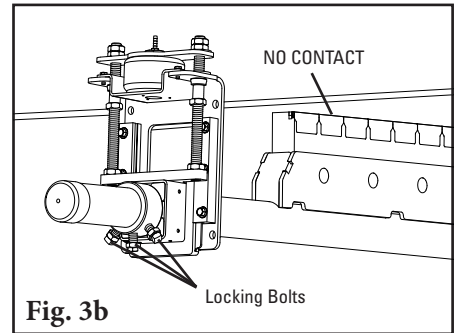

Fig. 3b

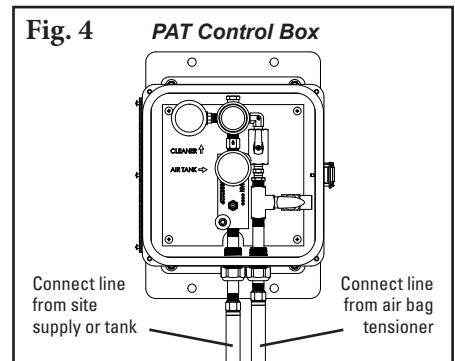

Fig. 4

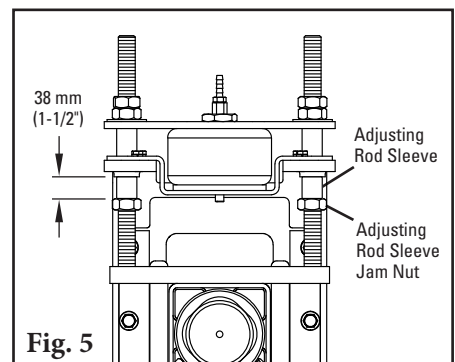
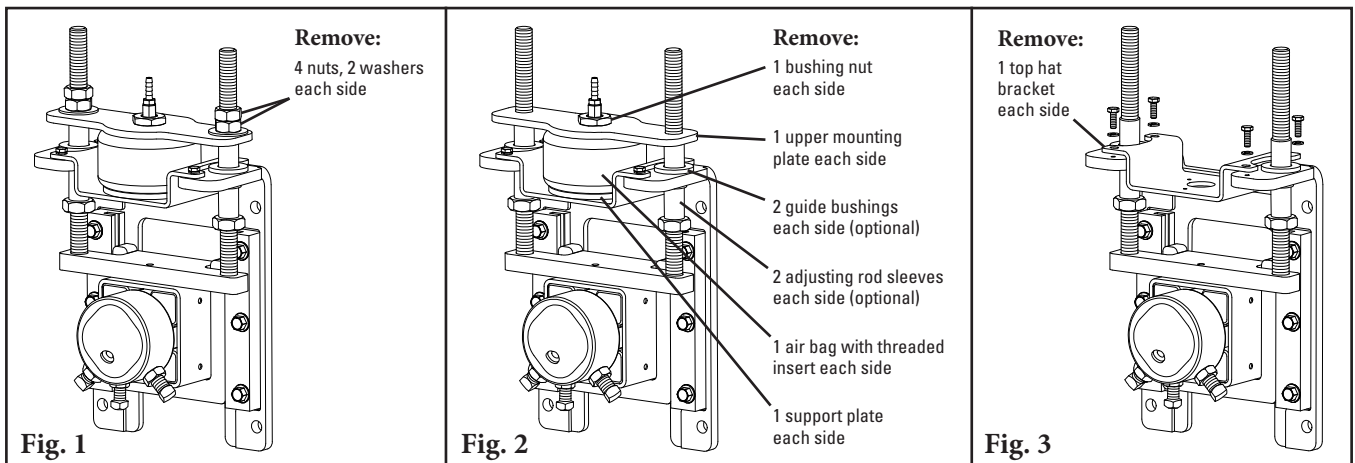

Fig. 5

Section 4 - Installation Instructions

4.4 CBS - SAT XD - Push-up Tensioning

1. **Disassemble guide kit.** Remove nuts and washers from both sides of tensioner (Fig. 1).
2. **Disassemble upper mounting plate and air bag.** Remove and save bushing nut. Remove and discard upper mounting plate. Remove (unscrew) and save air bag, threaded insert and support plate (Fig. 2).
Optional: Remove the guide bushings and adjusting rod sleeves. It will not affect the tensioner if these are left in place.
3. **Remove and save top hat bracket and its hardware** (Fig. 3).
4. **Flip over PAT mounting bracket assembly.** The two flanges are now at the bottom.



5. **Reassemble the SAT XD Tensioner.** Remove three screws from air bag support plate (Fig. 4a). Turn the threaded insert into the support plate. Also turn part of the threaded insert into the hole on pole mount. (Fig. 4b). Ensure 6 mm (1/4") of threaded insert is still exposed, then turn the air bag onto the threaded insert and tighten (Fig. 5).
6. **Reassemble top hat bracket.** Ensure bracket is resting on flanges of mounting bracket (Fig. 6). Adjust rod sleeves into bushings and lock with jam nuts.
7. **Slide pole mount/threaded rods/air bag assembly down** with hose barb through hole in top hat bracket and reinstall bushing nut (Fig. 6).
8. **Complete installation** by following the steps on page 14.

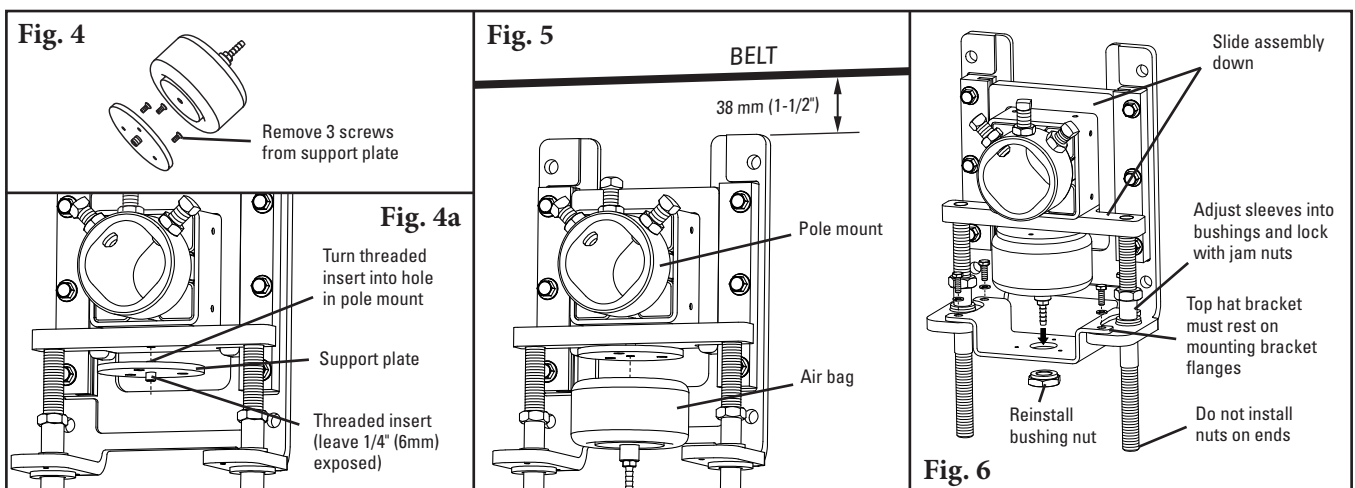

Section 5 - Pre-Operation Checklist and Testing

5.1 Pre-Op Checklist

- Recheck that all fasteners are tightened properly.
- Add pole caps.
- Apply all supplied labels to the cleaner.
- Check the blade location on the belt.
- Be sure that all installation materials and tools have been removed from the belt and the conveyor area.

5.2 Test Run the Conveyor

- Run the conveyor for at least 15 minutes and inspect the cleaning performance.
- Check the tensioner spring for recommended length (proper tensioning).
- Make adjustments as necessary.

NOTE: Observing the cleaner when it is running and performing properly will help to detect problems or when adjustments are needed later.

Section 6 - Maintenance

Flexco belt cleaners are designed to operate with minimum maintenance. However, to maintain superior performance some service is required. When the cleaner is installed a regular maintenance program should be set up. This program will ensure that the cleaner operates at optimal efficiency and problems can be identified and fixed before the cleaner stops working.

All safety procedures for inspection of equipment (stationary or operating) must be observed. The CBS Belt Cleaner operates at the discharge end of the conveyor and is in direct contact with the moving belt. Only visual observations can be made while the belt is running. Service tasks can be done only with the conveyor stopped and by observing the correct lockout/tagout procedures.

6.1 New Installation Inspection

After the new cleaner has run for a few days a visual inspection should be made to ensure the cleaner is performing properly. Make adjustments as needed.

6.2 Routine Visual Inspection (every 2-4 weeks)

A visual inspection of the cleaner and belt should look for:

- If spring length is the correct length for optimal tensioning.
- If belt looks clean or if there are areas that are dirty.
- If blade is worn out and needs to be replaced.
- If there is damage to the blade or other cleaner components.
- If fugitive material is built up on cleaner or in the transfer area.
- If there is cover damage to the belt.
- If there is vibration or bouncing of the cleaner on the belt.
- If a snub pulley is used, a check should be made for material buildup on the pulley.
- Significant signs of carryback.

If any of the above conditions exist, a determination should be made on when the conveyor can be stopped for cleaner maintenance.

6.3 Routine Physical Inspection (every 6-8 weeks)

When the conveyor is not in operation and properly locked and tagged out, a physical inspection of the cleaner to perform the following tasks:

- Clean material buildup off of the cleaner blade and pole.
- Closely inspect the blade for wear and any damage. Replace if needed.
- Ensure full blade to belt contact.
- Inspect the cleaner pole for damage.
- Inspect all fasteners for tightness and wear. Tighten or replace as needed.
- Replace any worn or damaged components.
- Check the tension of the cleaner blade to the belt. Adjust the tension if necessary using the chart on the cleaner or the ones on Pages 10 & 14 (SST XD or SAT XD).
- When maintenance tasks are completed, test run the conveyor to ensure the cleaner is performing properly.

Section 6 - Maintenance

6.4 Maintenance Log

Conveyor Name/No. _____

Date: _____ Work done by: _____ Service Quote #: _____

Activity: _____

Date: _____ Work done by: _____ Service Quote #: _____

Activity: _____

Date: _____ Work done by: _____ Service Quote #: _____

Activity: _____

Date: _____ Work done by: _____ Service Quote #: _____

Activity: _____

Date: _____ Work done by: _____ Service Quote #: _____

Activity: _____

Date: _____ Work done by: _____ Service Quote #: _____

Activity: _____

Date: _____ Work done by: _____ Service Quote #: _____

Activity: _____

Date: _____ Work done by: _____ Service Quote #: _____

Activity: _____

Section 6 - Maintenance

6.5 Cleaner Maintenance Checklist

Site: _____ Inspected by: _____ Date: _____

Belt Cleaner: _____ Serial Number: _____

Beltline Information:

Beltline Number: _____ Belt Condition: _____

Belt Width: 450mm (18") 600mm (24") 750mm (30") 900mm (36") 1050mm (42") 1200mm (48") 1350mm (54") 1500mm (60") 1800mm (72") 2100mm (84") 2400mm (96")

Belt Speed: _____ fpm Belt Thickness: _____

Belt Splice: _____ Condition of Splice: _____ Number of Splices: _____ Skived Unskived *Mechanical fasteners recommended for skived belts.

Material conveyed: _____

Days per week run: _____ Hours per day run: _____

Blade Life:

Date blade installed: _____ Date blade inspected: _____ Estimated blade life: _____

Is blade making complete contact with belt? Yes No

Blade wear: Left _____ Middle _____ Right _____

Blade condition: Good Grooved Smiled Not contacting belt Damaged

Measurement of spring: Required _____ Currently _____

For SAT XD Tensioner only: Air/Nitrogen Pressure Required _____ Currently _____
Inspect SAT XD bags and lines

Was Cleaner Adjusted: Yes No

Pole Condition: Good Bent Worn

Lagging: Side Lag Ceramic Rubber Other None

Condition of lagging: Good Bad Other: _____

Cleaner's Overall Performance: (Rate the following 1 - 5, 1= very poor - 5 = very good)

Appearance: : Comments: _____

Location: : Comments: _____

Maintenance: : Comments: _____

Performance: : Comments: _____

Other comments: _____



Section 7 - Troubleshooting

Problem	Possible Cause	Possible Solutions
Vibration	Cleaner secure bolts not set	Ensure all locking nuts are tight (Loctite)
	Cleaner not set up correctly	Ensure cleaner set up properly (check tip angle with gauge)
	Belt tension too high	Ensure cleaner can conform to belt, or replace with alternate Flexco secondary cleaner
	Belt flap	Introduce hold-down roller to flatten belt
	Cleaner over-tensioned	Ensure cleaner is correctly tensioned
	Cleaner under-tensioned	Ensure cleaner is correctly tensioned
	Nylon bearing worn out or missing	Replace nylon bearing
Material buildup on cleaner	Cleaner not set up correctly	Ensure cleaner set up properly (5° laid back)
	Buildup on chute	Ensure cleaner is not located too close to back of chute, allowing buildup
	Cleaner being overburdened	Introduce Flexco precleaner
	Excessive sticky material	Frequently clean unit of buildup
Damaged belt cover	Cleaner over-tensioned	Ensure cleaner is correctly tensioned
	Cleaner blade damage	Check blade for wear, damage and chips, replace where necessary
	Attack angle not correct	Ensure cleaner set up properly (check tip angle with gauge)
	Material buildup in chute	Frequently clean unit of buildup
Cleaner not conforming to belt	Cleaner not set up correctly	Ensure cleaner set up properly (check tip angle with gauge)
	Belt tension too high	Ensure cleaner can conform to belt (introduce hold-down roller), or replace with alternate Flexco secondary cleaner
	Belt flap	Introduce hold-down roller to flatten belt
	Cleaner cannot conform	Ensure cleaner can conform to belt (introduce hold-down roller), or replace with alternate Flexco secondary cleaner
Material passing cleaner	Cleaner not set up correctly	Ensure cleaner set up properly (check tip angle with gauge)
	Cleaner tension too low	Ensure cleaner is correctly tensioned
	Cleaner blade worn/damaged	Check blade for wear, damage and chips, replace where necessary
	Cleaner being overburdened	Introduce Flexco precleaner
	Belt flap	Introduce hold-down roller to flatten belt
	Belt worn or grooved	Introduce water spray pole
	Cleaner cannot conform	Ensure cleaner can conform to belt (introduce hold-down roller), or replace with alternate Flexco secondary cleaner
	Blade in backwards	Install blade correctly and set correct tension
Damage to mechanical fastener	Incorrect cleaner blade selection	Change blade type to accommodate fastener style (UC or UF)
	Belt not skived correctly	Spot and redo splice correctly, lowering the profile flush or below belt surface
	Blade angle incorrect	Reset with gauge
Missing material in belt center only	Cupped Belt	Install hold-down roller and reset blade angle with gauge
	Cleaner blade worn/damaged	Check blade for wear, damage and chips, replace where necessary
Missing material on outer edges only	Cupped Belt	Install hold-down roller and reset blade angle with gauge
	Cleaner blade worn/damaged	Check blade for wear, damage and chips, replace where necessary

Section 8 - Specs and CAD Drawings

8.1 Specs and Guidelines

Pole Length Specifications*

CLEANER SIZE		BELT WIDTH		POLE LENGTH		MAXIMUM CONVEYOR SPAN	
mm	in.	mm	in.	mm	in.	mm	in.
450	18	450	18	1800	72	1550	62
600	24	600	24	1950	78	1700	68
750	30	750	30	2100	84	1850	74
900	36	900	36	2250	90	2000	80
1050	42	1050	42	2400	96	2150	86
1200	48	1200	48	2550	102	2300	92
1350	54	1350	54	2700	108	2450	98
1500	60	1500	60	2850	114	2600	104
1800	72	1800	72	3150	126	2900	116
2100	84	2100	84	3450	138	3200	128
2400	96	2400	96	3750	150	3500	140

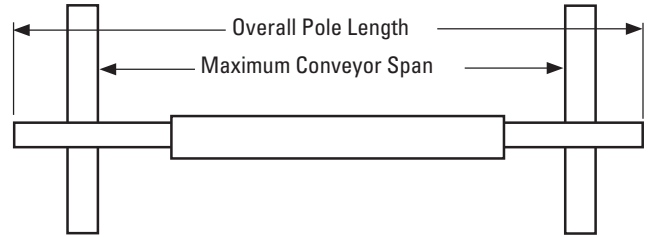

*For special extra long pole length requirements a Pole Extender Kit (#76024) is available that provides 750 mm (30") of extended pole length. See Page 7. Pole Diameter - 73 mm (2-7/8")

Clearance Guidelines for Installation

HORIZONTAL CLEARANCE REQUIRED		VERTICAL CLEARANCE REQUIRED	
mm	in.	mm	in.
115	4-1/2	254	10

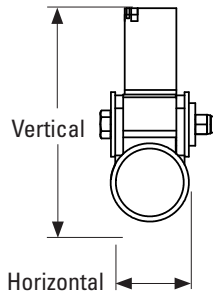

SST XD Spring Length Chart

Belt Width		White Springs		Silver Springs		Black Springs		Gold Springs	
mm	in.	mm	in.	mm	in.	mm	in.	mm	in.
450	18	86	3 3/8	102	4	N/A	N/A	N/A	N/A
600	24	79	3 1/8	98	3 7/8	N/A	N/A	N/A	N/A
750	30	73	2 7/8	95	3 3/4	N/A	N/A	N/A	N/A
900	36	N/A	N/A	95	3 3/4	98	3 7/8	N/A	N/A
1050	42	N/A	N/A	92	3 5/8	95	3 3/4	N/A	N/A
1200	48	N/A	N/A	89	3 1/2	92	3 5/8	N/A	N/A
1350	54	N/A	N/A	86	3 3/8	92	3 5/8	95	3 3/4
1500	60	N/A	N/A	83	3 1/4	89	3 1/2	95	3 3/4
1800	72	N/A	N/A	N/A	N/A	86	3 3/8	92	3 5/8
2100	84	N/A	N/A	N/A	N/A	79	3 1/8	89	3 1/2
2400	96	N/A	N/A	N/A	N/A	N/A	N/A	86	3 3/8

Shading indicates preferred spring option.

SAT XD Pressure Chart

Belt Width		Pressure	
mm	in.	kPa	psi
450	18	103	15
600	24	131	19
750	30	159	23
900	36	186	27
1050	42	214	31
1200	48	241	35
1350	54	269	39
1500	60	296	43
1800	72	352	51
2100	84	407	59
2400	96	462	67

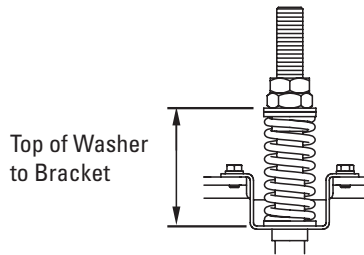

Specifications:

- Maximum Belt Speed4 m/s (800 FPM) 4 m/s (800 FPM) for mechanical fasteners
6 m/s (1200 FPM) for vulcanized belts
- Temperature Rating-35 to 82°C (-30 to 180°F)
- Available for Belt Widths450 to 2400 mm (18 to 96"). Other sizes available upon request.

Section 8 - Specs and CAD Drawings

8.2 CAD Drawing - CBS Flat - SST XD

SPECIFICATIONS			CBS CLEANER	
BELT WIDTH 'A'	POLE LENGTH 'B'	ORDER NUMBER	ITEM CODE	
(in)	(mm)	(in)	(mm)	
18	480	72	1829	CBS18SF 79936
24	600	78	1981	CBS24SF 79937
30	700	84	2134	CBS30SF 79938
36	900	90	2286	CBS36SF 79939
42	1050	96	2438	CBS42SF 79940
48	1200	102	2591	CBS48SF 79941
54	1350	108	2743	CBS54SF 79942
60	1500	114	2896	CBS60SF 79943
72	1800	126	3200	CBS72SF 79944
84	2100	138	3505	CBS84SF 79945
96	2400	150	3810	CBS96SF 79946

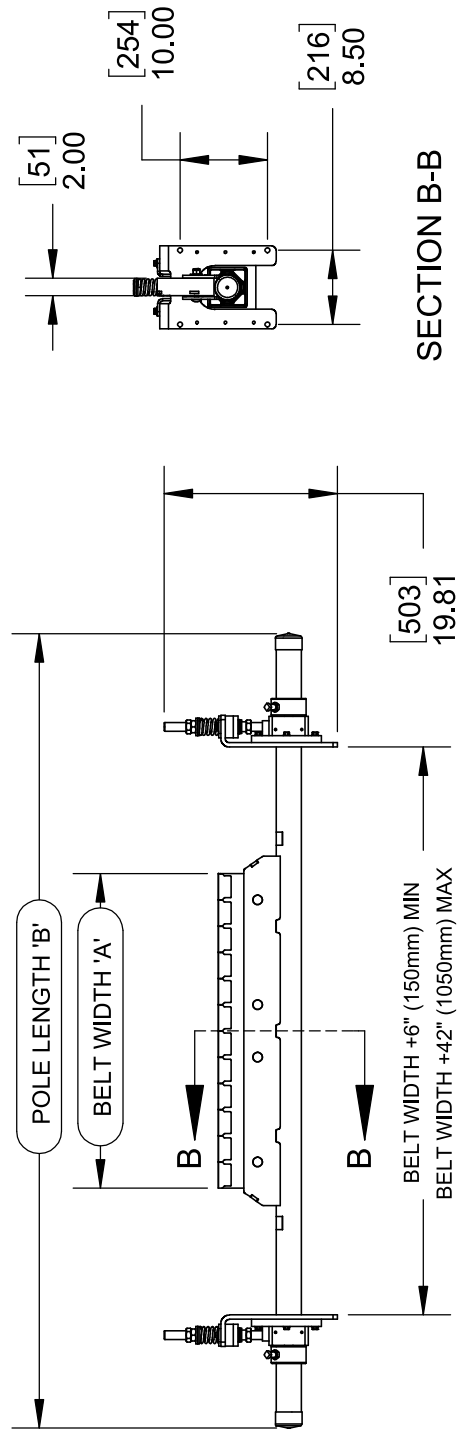

SECTION B-B

Section 8 - Specs and CAD Drawings

8.3 CAD Drawing - CBS Curved - SST XD

SPECIFICATIONS			CBS CLEANER	
BELT WIDTH 'A'	POLE LENGTH 'B'		ORDER NUMBER	ITEM CODE
(in)	(mm)	(in)	(mm)	
18	480	73	1854	91495
24	600	79	2007	91496
30	700	85	2159	91497
36	900	91	2311	91498
42	1050	97	2464	91499
48	1200	103	2616	91500
54	1350	109	2769	91501
60	1500	115	2921	91502
72	1800	127	3226	91503
84	2100	139	3531	91504
96	2400	151	3835	91505

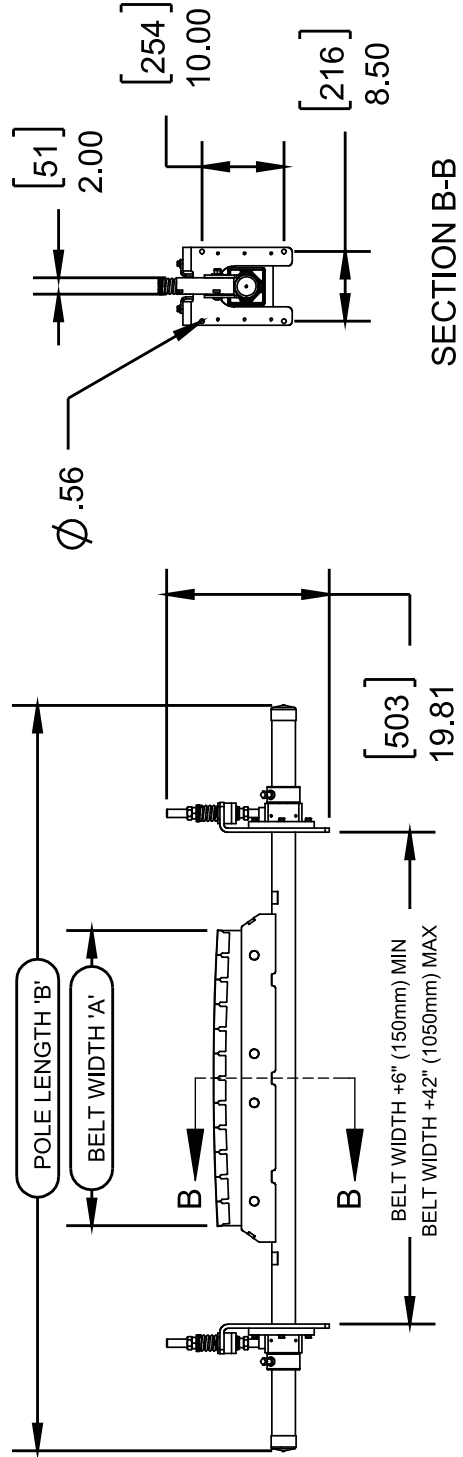

Section 8 - Specs and CAD Drawings

8.4 CAD Drawing - CBS Flat - SAT XD

SPECIFICATIONS				CBS CLEANER	
BELT WIDTH "A"		POLE LENGTH "B"		ORDER NUMBER	ITEM CODE
(in)	(mm)	(in)	(mm)		
18	480	73	1854	CBS18PF	79958
24	600	79	2007	CBS24PF	79959
30	700	85	2159	CBS30PF	79960
36	900	91	2311	CBS36PF	79961
42	1050	97	2464	CBS42PF	79962
48	1200	103	2616	CBS48PF	79963
54	1350	109	2769	CBS54PF	79964
60	1500	115	2921	CBS60PF	79965
72	1800	127	3226	CBS72PF	79966
84	2100	139	3531	CBS84PF	79967
96	2400	151	3835	CBS96PF	79968

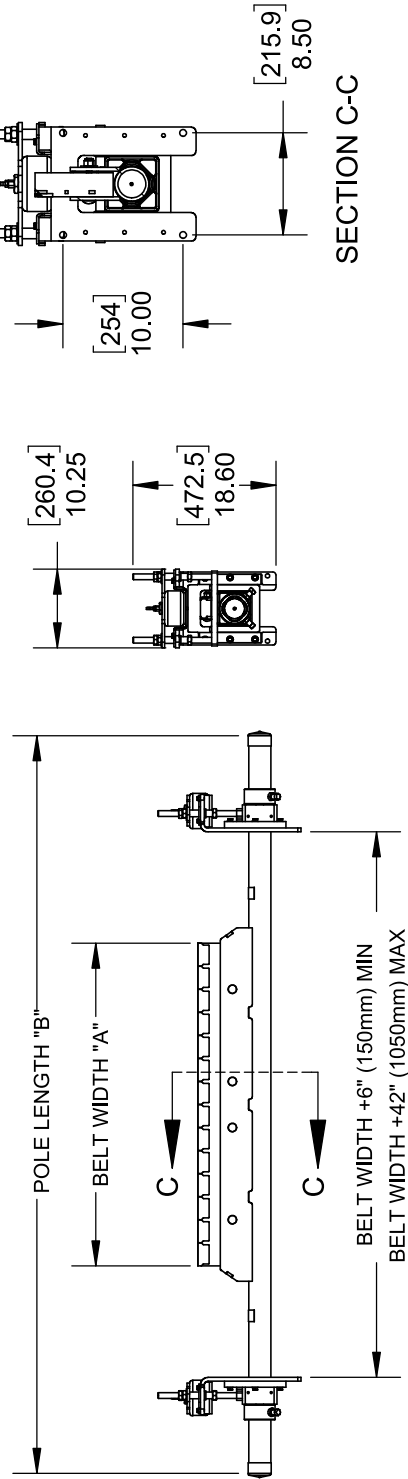

Section 8 - Specs and CAD Drawings

8.5 CAD Drawing - CBS Curved - SAT XD

SPECIFICATIONS			CBS CLEANER		
BELT WIDTH "A"		POLE LENGTH "B"		ORDER NUMBER	ITEM CODE
(in)	(mm)	(in)	(mm)		
18	480	73	1854	CBS18PC	91549
24	600	79	2007	CBS24PC	91550
30	700	85	2159	CBS30PC	91551
36	900	91	2311	CBS36PC	91552
42	1050	97	2464	CBS42PC	91553
48	1200	103	2616	CBS48PC	91554
54	1350	109	2769	CBS54PC	91555
60	1500	115	2921	CBS60PC	91556
72	1800	127	3226	CBS72PC	91557
84	2100	139	3531	CBS84PC	91558
96	2400	151	3835	CBS96PC	91559

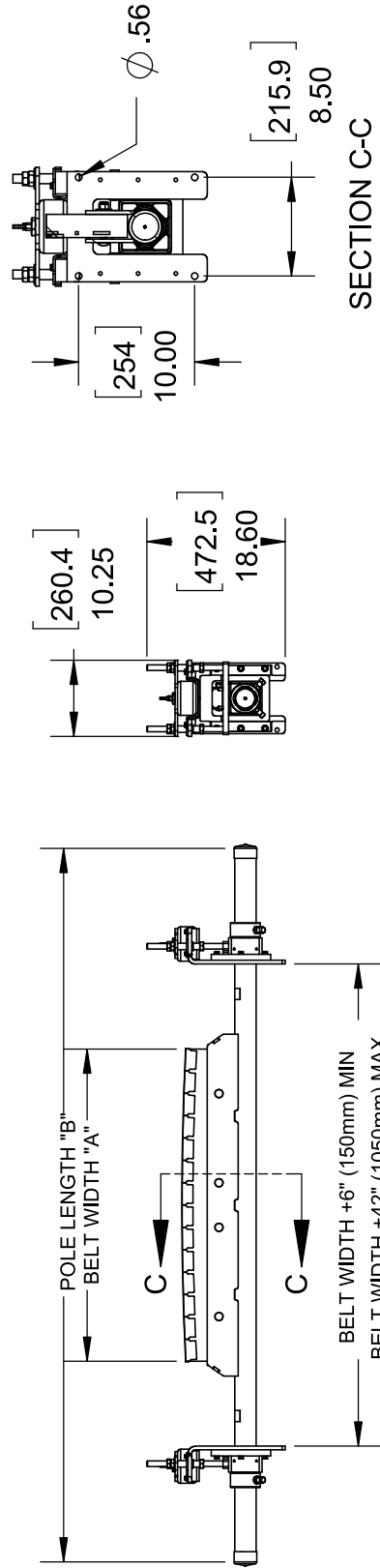

Section 9 - Replacement Parts

9.1 Replacement Parts List - Blades & Poles

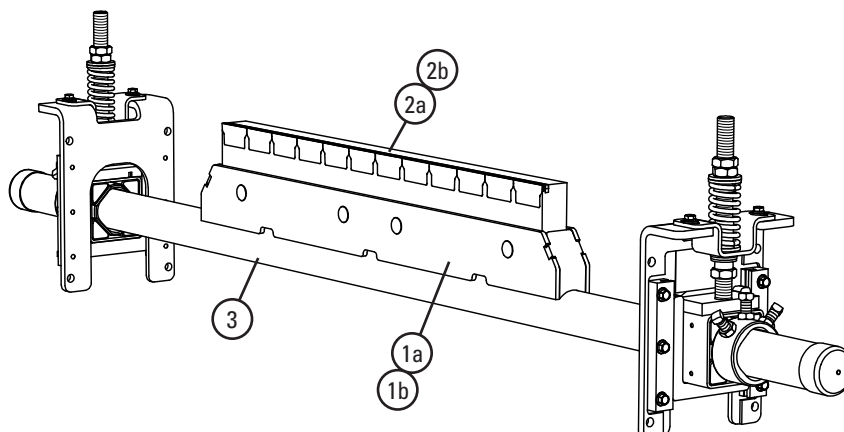

Replacement Parts - Blades & Poles

REF	DESCRIPTION	FLAT BLADE		CURVED BLADE		WT. KG	
		ORDERING NUMBER	ITEM CODE	ORDERING NUMBER	ITEM CODE		
1a (flat)	450mm (18") CBS Blade/Pole	CBSBP18F	90101	CBSBP18C	91538	38.1	
	600mm (24") CBS Blade/Pole	CBSBP24F	90102	CBSBP24C	91539	44.4	
	750mm (30") CBS Blade/Pole	CBSBP30F	90103	CBSBP30C	91540	50.8	
	900mm (36") CBS Blade/Pole	CBSBP36F	90104	CBSBP36C	91541	57.1	
	1050mm (42") CBS Blade/Pole	CBSBP42F	90105	CBSBP42C	91542	63.5	
	1200mm (48") CBS Blade/Pole	CBSBP48F	90106	CBSBP48C	91543	69.8	
	1b (curved)	1350mm (54") CBS Blade/Pole	CBSBP54F	90107	CBSBP54C	91544	76.2
		1500mm (60") CBS Blade/Pole	CBSBP60F	90108	CBSBP60C	91545	82.5
		1800mm (72") CBS Blade/Pole	CBSBP72F	90109	CBSBP72C	91546	95.2
		2100mm (84") CBS Blade/Pole	CBSBP84F	90110	CBSBP84C	91547	107.9
		2400mm (96") CBS Blade/Pole	CBSBP96F	90111	CBSBP96C	91548	120.6
2a (flat)	450mm (18") CBS Blade	CBSBLD18F	79947	CBSBLD18C	91527	7.3	
	600mm (24") CBS Blade	CBSBLD24F	79948	CBSBLD24C	91528	10.0	
	750mm (30") CBS Blade	CBSBLD30F	79949	CBSBLD30C	91529	12.2	
	900mm (36") CBS Blade	CBSBLD36F	79950	CBSBLD36C	91530	15.0	
	1050mm (42") CBS Blade	CBSBLD42F	79951	CBSBLD42C	91531	17.7	
	1200mm (48") CBS Blade	CBSBLD48F	79952	CBSBLD48C	91532	20.4	
	2b (curved)	1350mm (54") CBS Blade	CBSBLD54F	79953	CBSBLD54C	91533	22.7
		1500mm (60") CBS Blade	CBSBLD60F	79954	CBSBLD60C	91534	25.4
		1800mm (72") CBS Blade	CBSBLD72F	79955	CBSBLD72C	91535	30.4
		2100mm (84") CBS Blade	CBSBLD84F	79956	CBSBLD84C	91536	35.8
		2400mm (96") CBS Blade	CBSBLD96F	79957	CBSBLD96C	91537	40.8
3	450mm (18") CBS Repl Pole	CBSP18	91432			30.8	
	600mm (24") CBS Repl Pole	CBSP24	91433			34.5	
	750mm (30") CBS Repl Pole	CBSP30	91434			38.5	
	900mm (36") CBS Repl Pole	CBSP36	91435			42.2	
	1050mm (42") CBS Repl Pole	CBSP42	91436			45.8	
	1200mm (48") CBS Repl Pole	CBSP48	91437			49.4	
	1350mm (54") CBS Repl Pole	CBSP54	91438			53.5	
	1500mm (60") CBS Repl Pole	CBSP60	91439			57.1	
	1800mm (72") CBS Repl Pole	CBSP72	91440			64.9	
	2100mm (84") CBS Repl Pole	CBSP84	91441			72.1	
	2400mm (96") CBS Repl Pole	CBSP96	91442			79.8	

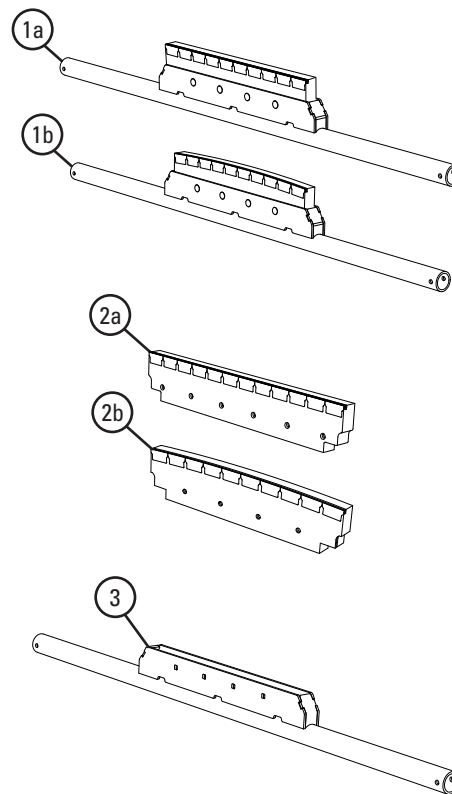

Shaded items are made to order.
Lead time: 3 weeks

*Hardware Included
Lead time: 1 working day

Section 9 - Replacement Parts

9.2 Replacement Parts List - SST XD/SAT XD Tensioners

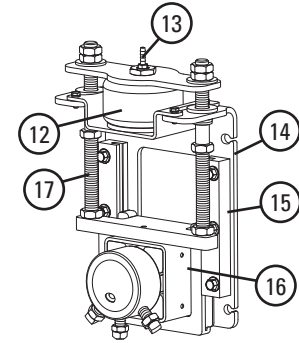
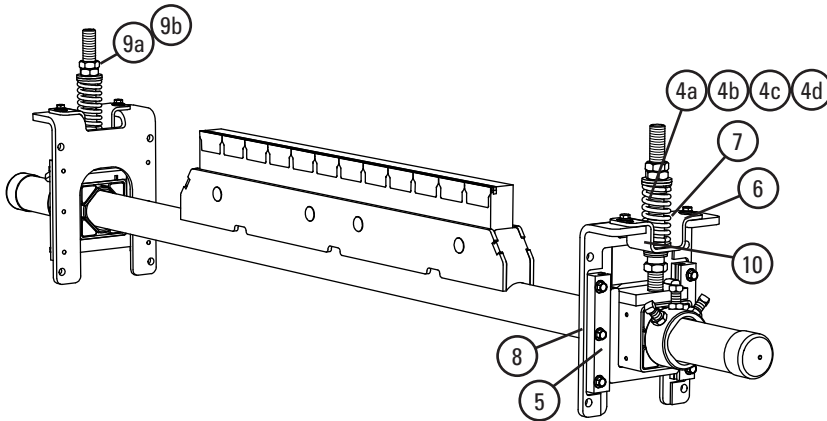

11 Secondary Air Tensioner XD

Replacement Parts - SST XD Tensioner

REF	DESCRIPTION	ORDERING NUMBER	ITEM CODE	WT. KG
4a	Tension Spring – White (1 ea.) for belts 450–750mm (18–30")	STS-W	75846	0.2
4b	Tension Spring – Silver (1 ea.) for belts 900–1200mm (36–48")	STS-S	75843	0.4
4c	Tension Spring – Black (1 ea.) for belts 1350–2100mm (54–84")	STS-B	75844	0.5
4d	Tension Spring – Gold (1 ea.) for belts 2400mm (96")	STS-G	78142	0.6
5	HD Torsion Pole Mount* (1 ea.) (includes HD adjusting rod, nuts & sleeve) (See 9a & 9b for bushings)	SSTHDPM	77868	6.8
6	SST XD Mounting Base Kit* (includes 1 mtg base, 2 slide guides, top hat bracket & bottom bushing)	SSTXDMK	91412	4.6
7	SST Hat Bracket (pair)	SSTHB	79582	1.4
8	Slide Guide Kit* (incl. 2 slide guides)	STGK2	77867	0.5
9a	SST Bushing Kit - White/Silver (includes 2 bushings)	SSTBK-W	76636	0.0
9b	SST Bushing Kit - Black/Gold (includes 2 bushings)	SSTBK-B	76637	0.0
10	SST Lower Bushing Kit (pair)	SSTLBK	79493	0.1
–	SST XD Spring Tensioner* – White (includes 2 each items 4a, 5, 6, & 9a) for belts 450–750mm (18–30")	SSTXD-W	91408	27.5
–	SST XD Spring Tensioner* – Silver (includes 2 each items 4b, 5, 6, & 9a) for belts 900–1200mm (36–48")	SSTXD-S	91409	27.8
–	SST XD Spring Tensioner* – Black (includes 2 each items 4c, 5, 6, & 9b) for belts 1350–2100mm (54–84")	SSTXD-B	91410	28.1
–	SST XD Spring Tensioner* – Gold (includes 2 each items 4d, 5, 6, & 9b) for belts 2400mm (96")	SSTXD-G	91411	28.4

*Hardware Included
Lead time: 1 working day

Replacement Parts - SAT XD Tensioner

REF	DESCRIPTION	ORDERING NUMBER	ITEM CODE	WT. KG
11	SAT XD	SATXDNCB	91414	18.6
12	SAT Air/Water Bag Kit	SATB	76083	2.3
13	SAT 1/8" Hose Barb Kit	SATHB	76084	0.0
14	SAT XD Mounting Base Kit	SATXDMK	91415	5.3
15	ST Slide Guide Kit	STGK2	77867	0.5
16	SAT2 Torsion Pole Mount	SAT2PM	78732	5.0
17	SAT2 Adjusting Rod Kit	SAT2AK	78733	2.3

Lead time: 1 working day

Spring Tensioner Selection Chart

CLEANER SIZE	91408 SSTXD-W	91409 SSTXD-S	91410 SSTXD-B	91411 SSTXD-G
CBS 450–750mm (18–30")	X			
CBS 900–1200mm (36–48")		X		
CBS 1350–2100mm (54–84")			X	
CBS 2400mm (96")				X

Section 10 - Other Flexco Conveyor Products

Flexco provides many conveyor products that help your conveyors to run more efficiently and safely. These components solve typical conveyor problems and improve productivity. Here is a quick overview on just a few of them:

MMP Precleaner



- Extra cleaning power right on the head pulley
- A 250 mm (10") TuffShear™ blade provides increased blade tension on the belt to peel off abrasive materials
- The unique Visual Tension Check™ ensures optimal blade tensioning and quick, accurate retensioning
- Easy to install and simple to service

DRX Impact Beds



- Exclusive Velocity Reduction Technology™ to better protect the belt
- Slide-Out Service™ gives direct access to all impact bars for change-out
- Impact bar supports for longer bar life
- 4 models to custom fit to the application

MDWS DryWipe Secondary Cleaner



- Wipes the belt dry as final cleaner in system
- Automatic blade tensioning to the belt
- Easy, visual blade tension check
- Simple, one-pin blade replacement

PT Max™ Belt Trainer



- Patented “pivot & tilt” design for superior training action
- Dual sensor rollers on each side to minimize belt damage
- Pivot point guaranteed not to freeze up
- Available for topside and return side belts

Flexco Specialty Belt Cleaners



- “Limited space” cleaners for tight conveyor applications
- High Temp cleaners for severe, high heat applications
- A rubber fingered cleaner for chevron and raised rib belts
- Multiple cleaner styles in stainless steel for corrosive applications

Belt Plows



- A belt cleaner for the tail pulley
- Exclusive blade design quickly spirals debris off the belt
- Economical and easy to service
- Available in vee or diagonal models

Visit www.flexco.com for other Flexco locations and products, or to find an authorised distributor.

©2022 Flexible Steel Lacing Company. 10-14-24. X5962

