

EZOE Rockline® Standard-Duty Precleaner

Simple, Quick, Effective Belt Cleaning for Pulp and Paper Operations

The EZOE Precleaner is not your average solid-blade belt cleaner that mounts on the head pulley. It features a unique single blade design that combines simple, do-it-yourself installation, quick maintenance, and effective cleaning with a price tag that you can afford. Install the EZOE on belts carrying bark or chips where dust is widespread to facilitate the capture of usable material and avoid material piles that create fire hazards. Stainless Steel components and Chemical-Resistant, High-Temp, or Ultra-High Temp blade options are available for belts carrying chips to the digester and lime to the kiln.



Faceted profile design
results in continuous blade edge "renewal" for improved cleaning efficiency throughout the life of the blade

High strength
aluminum extrusion



Pole plate pre-drilled
for material path options, 3 different blade widths available



Available with stainless steel components for superior corrosion resistance



Chemical-Resistant Blade



High-Temp Blade
135° C (275° F) with spikes to 160° C (325° F)



Ultra High-Temp Blade
200° C (400° F) with spikes to 230° C (450° F)

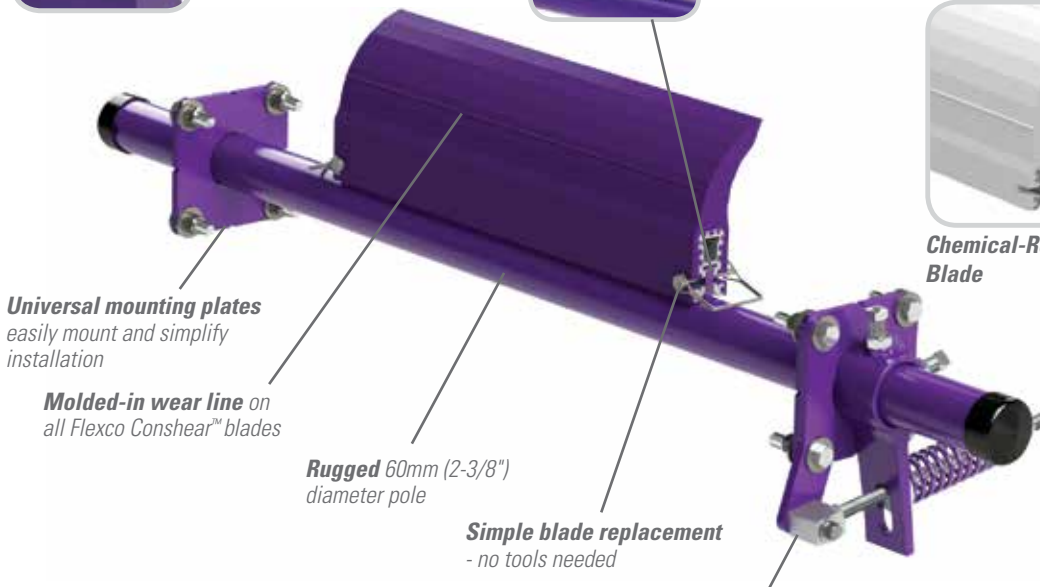

Universal mounting plates
easily mount and simplify installation

Molded-in wear line on all Flexco Conshear™ blades

Rugged 60mm (2-3/8") diameter pole

Simple blade replacement
- no tools needed

Self-contained spring tensioner
allows for measurable and verifiable tension

Features and Benefits

- **Works with Flexco mechanical splices.** The spring tensioner allows the blade to quickly move away from the belt when a splice passes. The polyurethane blade material easily glides over the splice without damage and with minimal cleaning disruption.
- **Compact, streamlined design.** The EZOE Precleaner requires only 100 mm (4") of horizontal clearance for correct installation. Its streamlined contours prevent material buildup on the blade or the pole.
- **Can be used on reversing belts.** Installing cleaners on both pulleys gives superior cleaning results on belts that run in both directions.
- **Fits most conveyor structures.** Available for belt widths from 300-1800 mm (12" to 72").
- **Blade can be used on other cleaners.** The ConShear™ blade can be used as a replacement blade on many OEM cleaners.

EZOE

Rockline® Standard-Duty Precleaner

Specifications and Guidelines

- Maximum Belt Speed**
 700 FPM (3.5 M/sec)
- Temperature Rating**
Purple/White: -35°C to 82°C (-30°F to 180°F)
Yellow: -35°C to 135°C (-30°F to 275°F)
 Spikes to 160°C (325°F)
Red: -35°C to 200°C (-30°F to 400°F)
 Spikes to 230°C (450°F)
- Minimum Pulley Diameter**
 250 mm (10")
- Blade Height**
 185 mm (7-1/4")
- Usable Blade Wear Length**
 100 mm (4")
- Blade Material**
Purple/White: Polyurethane 83 durometer
Yellow: Polyurethane 93 durometer
Red: Ultra High-Temp Polyurethane 90 durometer
- CEMA Cleaner Rating**
 Class 3
- Available for Belt Widths**
 300 to 1800 mm (12" to 72")
- Horizontal Clearance Required**
 100 mm (4")
- Vertical Clearance Required**
 238 mm (9-1/2")
- Pole Length**
 Cleaner size up to 1200mm + 750mm
 Cleaner size over 1200mm + 850mm
 (Cleaner size up to 48" + 30")
 (Cleaner size over 48" + 34")
- Maximum Conveyor Span**
 Cleaner size up to 1200mm + 625mm
 Cleaner size over 1200mm + 725mm
 (Cleaner size up to 48" + 25")
 (Cleaner size over 48" + 29")

Pole Location Specs

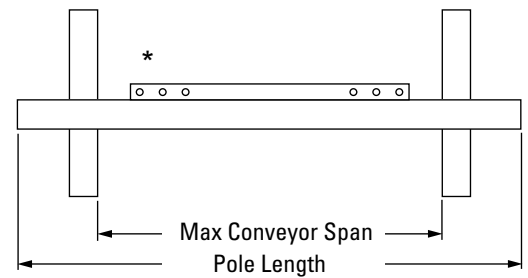
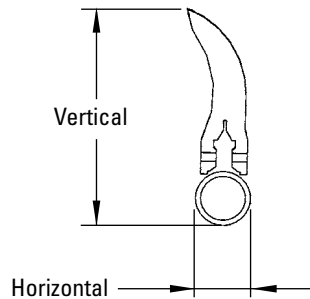
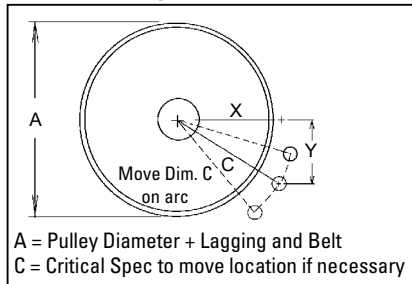

Pole Location Chart

A	X	Y	C	A	X	Y	C	A	X	Y	C
250	74	230	242	500	235	230	329	725	374	230	439
275	92	230	248	525	249	230	339	775	389	230	452
300	108	230	254	550	266	230	352	775	403	230	464
325	131	230	265	575	283	230	365	825	417	230	477
350	146	230	273	600	299	230	377	825	432	230	489
375	166	230	284	625	314	230	390	850	446	230	501
400	179	230	291	650	330	230	402	875	460	230	514
425	195	230	301	675	346	230	415	900	474	230	526
450	207	230	309	700	360	230	427				

Ordering Information

EZOE Precleaners - Belt Width -50mm (2") Blade		
Belt Width	Ordering Number	Item Code
600	EZOE-600-50	90910
750/800	EZOE-800-50	90911
1000/1050	EZOE-1000-50	90912
1200	EZOE-1200-50	90913
1350	EZOE-1400-50	90914
1500	EZOE-1500-50	90915
1800	EZOE-1800-50	90916

EZOE Precleaners - Belt Width -200mm (8") Blade		
Belt Width	Ordering Number	Item Code
600	EZOE-600-200	90917
750/800	EZOE-800-200	90918
1000/1050	EZOE-1000-200	90919
1200	EZOE-1200-200	90920
1350	EZOE-1400-200	90921
1500	EZOE-1500-200	90922
1800	EZOE-1800-200	90923

ConShear™ Replacement Blades		
Blade Width	Ordering Number	Item Code
200	CRB-OE200	78283
300	CRB-OE300	78284
350	CRB-OE350	78285
450	CRB-OE450	78286
600	CRB-OE600	78287
750	CRB-OE750	78288
800	CRB-OE800	78289
950	CRB-OE950	78290
1000	CRB-OE1000	78291
1150	CRB-OE1150	78292
1200	CRB-OE1200	78293
1350	CRB-OE1350	78294
1400	CRB-OE1400	78295
1550	CRB-OE1550	78296

Ordering information shown is for the standard mild steel EZOE with purple blade. Contact your Flexco distributor or visit www.flexco.com for other cleaner/blade options.



Authorized Distributor: