

EZP1 Rockline® Standard-Duty Precleaner

Simple, Quick, Effective Belt Cleaning for Pulp and Paper Operations

The EZP1 Precleaner is not your average solid-blade belt cleaner that mounts on the head pulley. It features a unique single blade design that combines simple, do-it-yourself installation, quick maintenance, and effective cleaning with a price tag that you can afford. Install the EZP1 on belts carrying bark or chips where dust is widespread to facilitate the capture of usable material and avoid material piles that create fire hazards. Stainless Steel components and Chemical-Resistant, High-Temp, or Ultra-High Temp blade options are available for belts carrying chips to the digester and lime to the kiln.

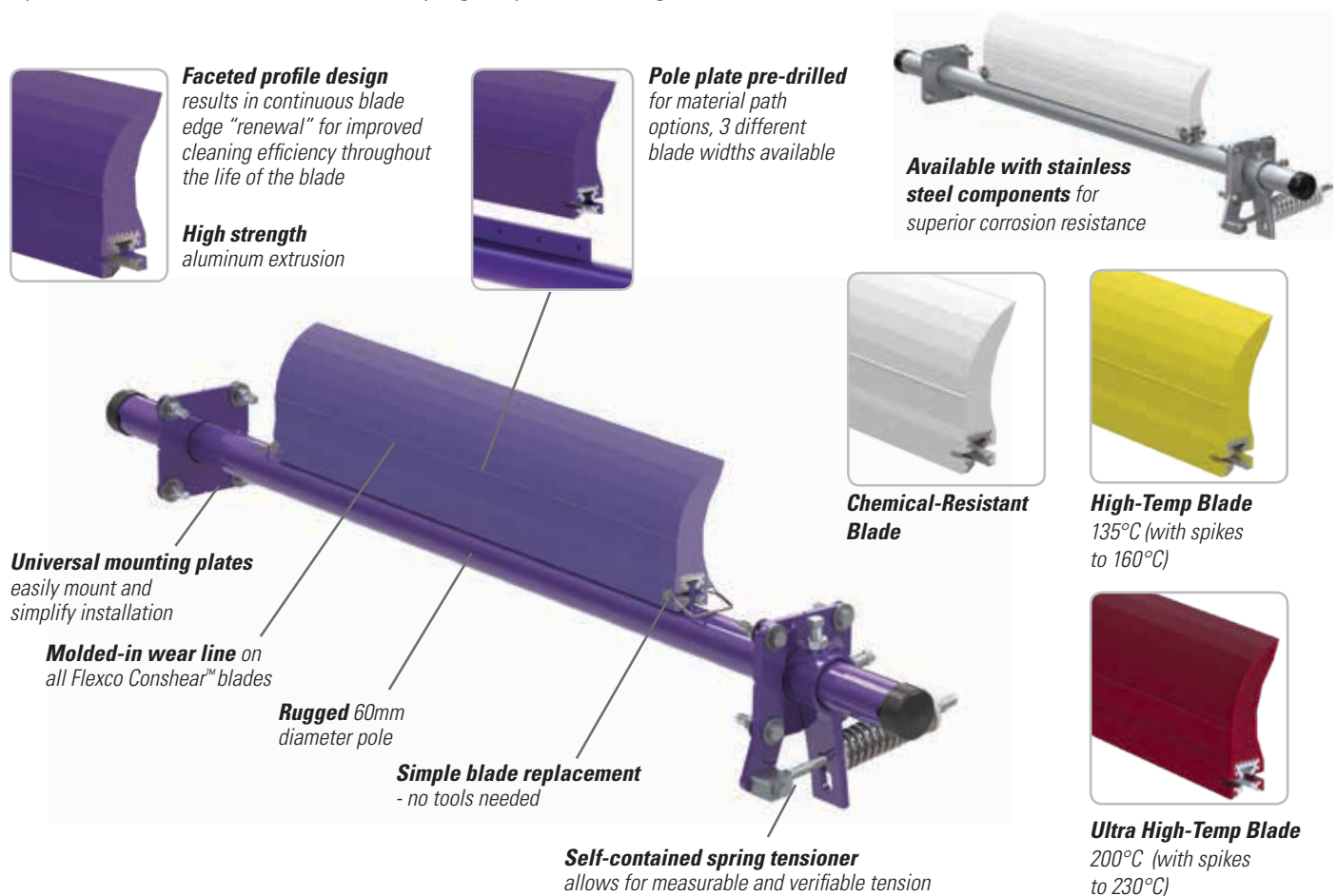

Features and Benefits

- **Works with Flexco mechanical splices.** The spring tensioner allows the blade to quickly move away from the belt when a splice passes. The polyurethane blade material easily glides over the splice without damage and with minimal cleaning disruption.
- **Compact, streamlined design.** The EZP1 Precleaner requires only 100 mm of horizontal clearance for correct installation. Its streamlined contours prevent material buildup on the blade or the pole.
- **Can be used on reversing belts.** Installing cleaners on both pulleys gives superior cleaning results on belts that run in both directions.
- **Fits most conveyor structures.** Available for belt widths from 300-1800 mm.
- **Blade can be used on other cleaners.** The ConShear™ blade can be used as a replacement blade on many OEM cleaners.

EZP1

Rockline® Standard-Duty Precleaner

Specifications and Guidelines

- Maximum Belt Speed**
3.5 m/s
- Temperature Rating**
Purple/White: -35°C to 82°C
Yellow: -35°C to 135°C
Spikes to 160°C
Red: -35°C to 200°C
Spikes to 230°C
- Minimum Pulley Diameter**
250 mm
- Blade Height**
185 mm
- Usable Blade Wear Length**
100 mm
- Blade Material**
Purple/White: Polyurethane 83 durometer
Yellow: Polyurethane 93 durometer
Red: Ultra High-Temp Polyurethane 90 durometer
- CEMA Cleaner Rating**
Class 3
- Available for Belt Widths**
300 to 1800 mm
- Horizontal Clearance Required**
100 mm
- Vertical Clearance Required**
238 mm
- Pole Length**
Cleaner size up to 1200mm + 750mm
Cleaner size over 1200mm + 850mm
- Maximum Conveyor Span**
Cleaner size up to 1200mm + 625mm
Cleaner size over 1200mm + 725mm

Pole Location Specs

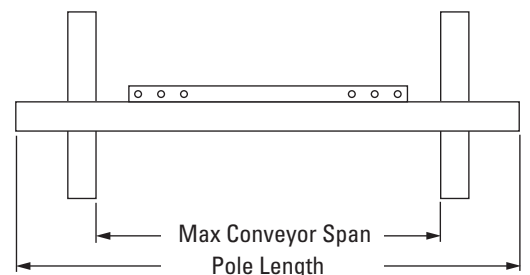
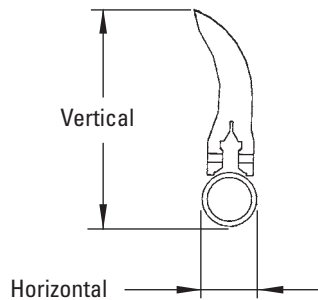
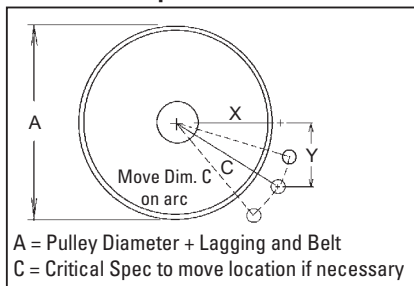

Pole Location Chart

A	X	Y	C	A	X	Y	C	A	X	Y	C
250	74	230	242	500	235	230	329	725	374	230	439
275	92	230	248	525	249	230	339	775	389	230	452
300	108	230	254	550	266	230	352	775	403	230	464
325	131	230	265	575	283	230	365	825	417	230	477
350	146	230	273	600	299	230	377	825	432	230	489
375	166	230	284	625	314	230	390	850	446	230	501
400	179	230	291	650	330	230	402	875	460	230	514
425	195	230	301	675	346	230	415	900	474	230	526
450	207	230	309	700	360	230	427				

Ordering Information

EZP1 Primary Cleaners - Belt Width Minus 50mm Blade			
Belt Width	Blade Coverage	Ordering Number	Item Code
mm	mm		
300	250	EZP1-300-50	81090
450	400	EZP1-450-50	81091
600	550	EZP1-600-50	81092
750	700	EZP1-750-50	81093
900	850	EZP1-900-50	81094
1050	1000	EZP1-1050-50	81095
1200	1150	EZP1-1200-50	81096
1350	1300	EZP1-1350-50	81097
1500	1450	EZP1-1500-50	81098
1800	1750	EZP1-1800-50	81099

EZP1 Primary Cleaners - Belt Width Minus 200mm Blade			
Belt Width	Blade Coverage	Ordering Number	Item Code
mm	mm		
300	-	N/A	N/A
450	250	EZP1-450-200	81100
600	400	EZP1-600-200	81101
750	550	EZP1-750-200	81102
900	700	EZP1-900-200	81103
1050	850	EZP1-1050-200	81104
1200	1000	EZP1-1200-200	81105
1350	1150	EZP1-1350-200	81106
1500	1300	EZP1-1500-200	81107
1800	1600	EZP1-1800-200	81108

ConShear™ Replacement Blades		
Blade Width	Ordering Number	Item Code
mm		
250	CRB-10	75628
400	CRB-16	75629
550	CRB-22	75630
700	CRB-28	75631
850	CRB-34	75632
1000	CRB-40	75633
1150	CRB-46	75634
1300	CRB-52	75635
1450	CRB-58	75636
1600	CRB-64	75775
1750	CRB-70	75773



Ordering information shown is for the standard mild steel EZP1 with purple blade.
Contact your Flexco distributor or visit www.flexco.com for other cleaner/blade options.

Authorized Distributor:

