

MSP

Ultra High Temperature Standard Mine-Duty Precleaner

Economical and Effective

Now there is a new polyurethane-blade precleaner that outperforms other “hot” blades. The Ultra High-Temp ConShear™ Blade is designed for continuous ambient temperatures up to 200°C and spikes to 232°C. This deep red blade takes the heat and yet provides the extended wear life of Flexco’s standard ConShear™ blade. More wear life means fewer blade change-outs.

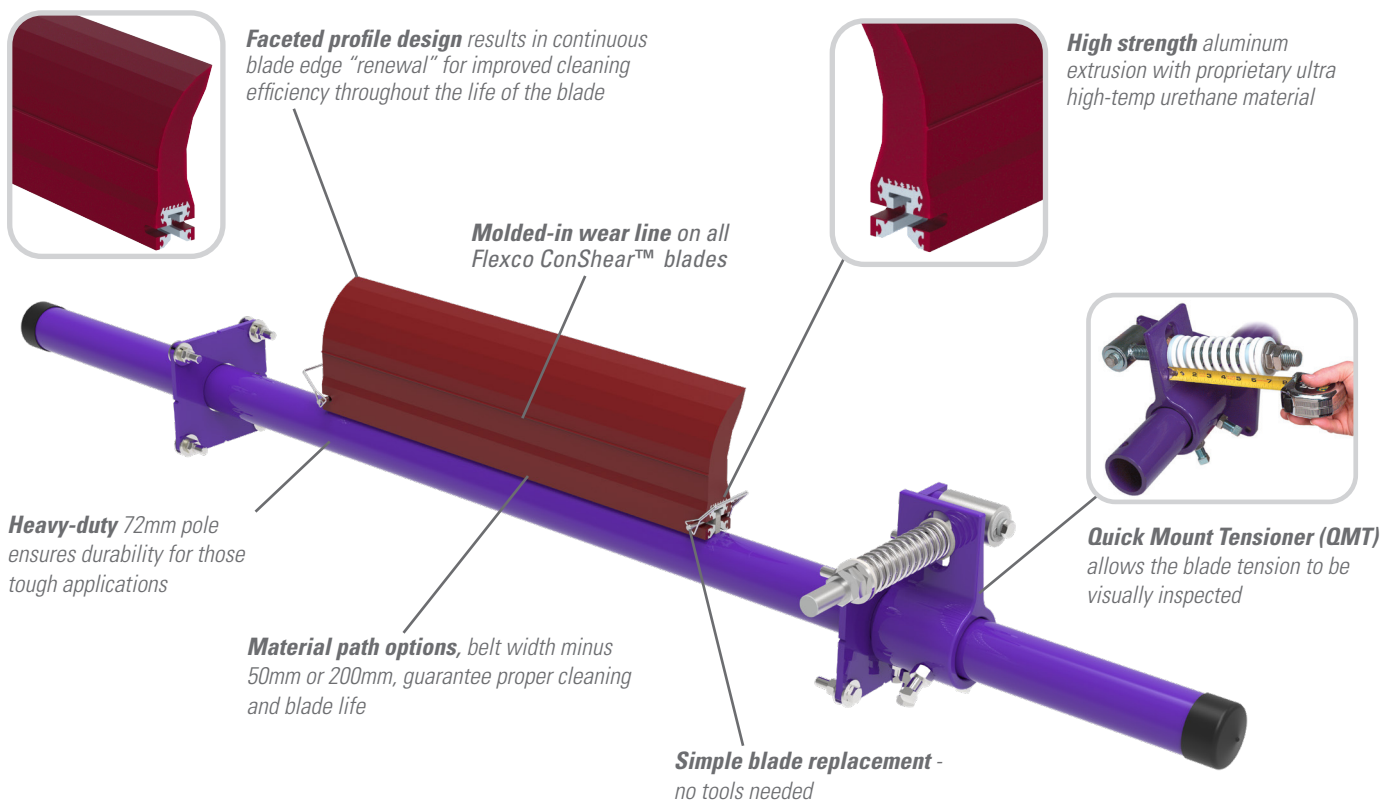

Features and Benefits

- **Quick-change blade.** No tools are needed. Just pull one pin, remove the old blade, slide in the new one and replace the pin.
- **Works with Flexco and other mechanical splices.** The spring tensioner quickly moves the blade away from the belt when a splice passes. The polyurethane blade easily glides over the splice without damage and with minimal cleaning disruption.
- **Easy to service.** All maintenance work is done from the easy-access side of the beltline. Blade retensioning and change-out are quick and easy.
- **Fits most conveyor structures.** Available for belt widths from 600 to 1800mm. The MSP poles are extra long (belt width plus 1350mm) to accommodate varying structure widths.

MSP

Ultra High-Temp Standard Mine-Duty Precleaner

Specifications and Guidelines

- **Maximum Belt Speed**
3.5 m/s
- **Temperature Rating**
Up to 200°C
with spikes up to 232°C
- **Minimum Pulley Diameter**
400mm
- **Blade Height**
185mm
- **Usable Blade Wear Length**
100mm
- **Blade Material**
Ultra High-Temp Polyurethane
90 durometer (proprietary
blend for abrasion resistance
and long wear)
- **Available for Belt Widths**
650–2000mm
- **CEMA Cleaner Rating**
Class 3
- **Horizontal Clearance Required**
100mm
- **Vertical Clearance Required**
254mm
- **Pole Length**
Cleaner size + 1400mm
- **Maximum Conveyor Span**
Cleaner size + 1150mm

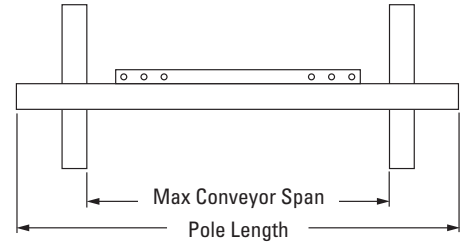
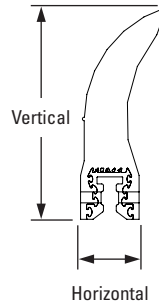

Pole Location Specs

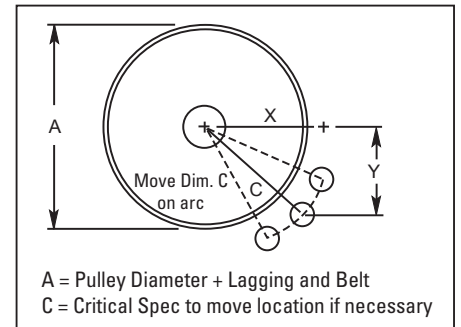

Ordering Information

MSP Ultra High-Temp Precleaner Belt Width Minus 50mm (2")			
Belt Width	Blade Width	Ordering Number	Item Code
mm	mm		
800	750	MSP-800-50UHT	91367
1000	950	MSP-1000-50UHT	91368
1200	1150	MSP-1200-50UHT	91369
1400	1350	MSP-1400-50UHT	91370
1600	1550	MSP-1600-50UHT	91371
1800	1750	MSP-1800-50UHT	91372
2000	1950	MSP-2000-50UHT	91373
Belt Width Minus 200mm (8")			
500–650	450	MSP-650-200UHT	91374
650–800	600	MSP-800-200UHT	91375
1000	800	MSP-1000-200UHT	91376
1200	1000	MSP-1200-200UHT	91377
1400	1200	MSP-1400-200UHT	91378
1600	1400	MSP-1600-200UHT	91379
1800	1600	MSP-1800-200UHT	91380
2000	1800	MSP-2000-200UHT	91381

Replacement UHT ConShear™ Blades		
Blade Width	Ordering Number	Item Code
mm		
450	CRB-UHT450	91332
600	CRB-UHT600	91333
750	CRB-UHT750	91334
800	CRB-UHT800	91335
950	CRB-UHT950	91336
1000	CRB-UHT1000	91337
1150	CRB-UHT1150	91338
1200	CRB-UHT1200	91339
1350	CRB-UHT1350	91340
1400	CRB-UHT1400	91341
1550	CRB-UHT1550	91342
1600	CRB-UHT1600	91343
1750	CRB-UHT1750	91344
1800	CRB-UHT1800	91345
1950	CRB-UHT1950	91346

Pole Location Chart			
A	X	Y	C
mm	mm	mm	mm
250	68	230	240
275	88	230	246
300	102	230	252
325	130	230	264
350	142	230	270
375	164	230	282
400	176	230	290
425	196	230	302
450	204	230	308
475	222	230	320
500	232	230	326
525	248	230	338
550	266	230	352
575	282	230	364
600	298	230	376
625	312	230	388
650	330	230	402
675	344	230	414
700	358	230	426
725	372	230	438
750	390	230	452
775	402	230	464
800	416	230	476
825	430	230	488
850	446	230	502
875	460	230	514
900	474	230	526
925	486	230	538
950	502	230	552
975	514	230	564
1000	528	230	576
1025	542	230	588
1050	556	230	602