

Clipper® Wire Hook System

Mechanical Fastening System of Choice for Parcel Handling

Since its inception, the Clipper® Wire Hook System has earned a reputation for continued innovation and proven performance. Clipper wire hooks have been designed with a variety of different wire diameters, leg and point lengths, metals, strip lengths and styles, such as Unibar® and carded. All are readily available to meet the needs of the Parcel Handling industry.

The double-staggered grip pattern gives wire hooks exceptional holding power without degrading the integrity of the belt carcass. Today's splices also have a very low profile, making them increasingly more compatible with conveyor components and compliant with the need for reduced operating noise.



CLIPPER®

Wire Hook System

Fastener Overview

Unibar® Fasteners

Unibar® fasteners are formed by welding each Clipper® hook to a common bar.



- Welded bar creates a stable strip of fasteners to eliminate damage during handling.
- Patented Safety Strip covers the hook points to protect fingertips, yet is easily removed prior to lacing.
- Hook legs are held parallel to simplify “meshing” of belt ends and the insertion of connecting pins.
- The risk of a single hook disengaging is significantly reduced, particularly important in the food industry.
- The welded bar creates a flat, finished splice so belt “wave” is eliminated.
- Under abusive applications, Unibar spreads shock loads to protect individual hooks.

Unibar fasteners can be easily cut to the appropriate length, or ordered in special lengths up to 1500 mm (60"). They are not recommended for bias splices, troughed belts where common bar breakage is a concern, and where special metals are required.

Carded Hooks

Individual Clipper hooks are secured on carding paper.



- Works with any application, including bias splices and troughed belt applications.

Available in a wide variety of metals and sizes.

36 Series Fasteners

Designed for mono/multifilament conveyor belting and filter media up to 4 mm (5/32") thick, and over pulleys as small as 24 mm (15/16"). Specially shaped wire is .9 mm (.036") wide and .7 mm (.027") high, with rounded sides and a flat top and bottom. Available in both Unibar® and carded hook styles.

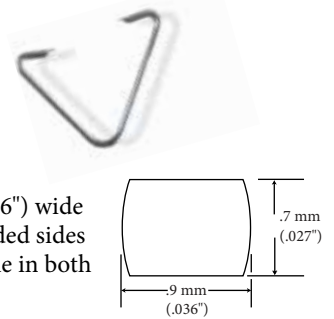

- High width-to-height ratio gives 36 Series fasteners increased mass and strength.
- Low profile reduces abrasion, wear, and noise.

36 Series fasteners are easy to handle and lace. They can be applied with all Clipper® lacers, including the Roller Lacer®, for easy on-site installation.

Fastener Material Characteristics

Metal	Magnetic Resistance	Abrasion Resistance	Chemical Resistance	Rust Resistance	Available Sizes	Sparking/ Non-Sparking
Galvanized	Yes	Good	Poor	Good	25, 1, 2-7	Sparking
Coated Steel™/Steel	Yes	Good	Poor	Poor	U2-U6	Sparking
High Tensile Steel	Yes	Good to Excellent	Fair	Good	1, 2-7	Sparking
Rectangular High Tensile Steel	Yes	Good to Excellent	Fair	Good	4½	Sparking
430 Stainless Steel	Yes	Good	Fair to Good	Good	1, UX1, 2-7, U2-U7	Sparking
316L Stainless Steel	Slightly	Good	Good to Excellent	Excellent	25, 36, 1, 2-7, UX1, UCM36, U2-U6	Sparking
Monel® 400	Slightly	Fair	Excellent	Excellent	25, 1, 2-4	Sparking
Inconel® 600	No	Fair	Excellent	Excellent, even at elevated temperatures	2-4	Sparking
Phosphor Bronze	No	Good	Poor	Good	2-4	Non-Sparking
Hastelloy C-22	No	Good	Excellent	Excellent	36, UCM36, 1, UX1, 3-4	Sparking
Black Oxide	Yes	Good	Poor	Fair	25	Sparking

Fastener Selection Guidelines

Specify the Right Clipper® Fastener

1. Measure belt thickness.

Use the Clipper® hook gauge, micrometer, or caliper to measure belt thickness. If the belt has an impression cover, skive cover 25 mm (1") back from belt end prior to measuring. Do not cut belt carcass.

2. Measure pulley diameter.

The minimum pulley diameter is the smallest pulley that has a belt wrap of at least 90°.

3. Determine hook choices.

Referring to the chart on page 4, locate belt thickness on top of the chart and minimum pulley diameter on the left side. Using the matrix, determine the hook sizes most appropriate for your application. Do not select hooks that specify a larger minimum pulley – the leg length will be too long, causing leg fatigue and premature failure.

4. Select hook wire diameter.

Hooks are produced in various wire diameters. A splice made from a smaller wire diameter is quieter and wears less as it contacts conveyor components. A splice made from a larger wire diameter offers greater strength and abrasion resistance. Reference the “Wire Diameter” column on the chart on page 4. Choose a hook with a wire diameter that best suits your needs.

5. Select style.

Choose between Unibar® and carded fasteners based on your application requirements. All Unibar offerings begin with “U” (UCM, UX1, U2, etc.).

6. Select material.

Refer to the material selection chart on page 2 for the metal characteristics which best suit your application. Not all sizes and styles are available in all metals.



Skive impression cover.



Measure belt thickness.



Measure smallest pulley diameter.

Fastener Selection Guidelines

Please note this chart represents common hook sizes.

Additional sizes are available or can be custom made for specific application requirements.

Fastener and Pin Size Selection Chart

Minimum Pulley Diameter	Wire Diameter		Belt Thickness												
			1.2 mm	1.6 mm	2.4 mm	3.2 mm	4.0 mm	4.8 mm	5.6 mm	6.4 mm	7.1 mm	7.9 mm	9.0 mm	10.0 mm	
	mm	in.	Up to 3/64" .047"	1/16" .063"	3/32" .093"	1/8" .125"	5/32" .156"	3/16" .188"	7/32" .219"	1/4" .250"	9/32" .281"	5/16" .313"	11/32" .344"	25/64" .390"	
24 mm 15/16"	0.6	.025	25SP*												
	0.6	.025	25*												
	0.9 x 0.7	.036 x .027	UCM36SL XSP												
51 mm 2"	0.9 x 0.7	.036 x .027	UCM36 XSP												
	0.9 x 0.7	.036 x .027	UCM36 SP*												
	0.9 x 0.7	.036 x .027	36 SP*												
	1.0	.040	1 XSP*												
	1.0	.040	UX-1 SP*												
	0.9 x 0.7	.036 x .027	UCM36*												
	0.9 x 0.7	.036 x .027	36*												
	1.0	.040	1 SP*												
	0.9 x 0.7	.036 x .027	UCM36 LP*												
	1.0	.040	1*												
	1.0	.040	UX-1*												
	1.4	.054	U2 SP												
	1.4	.054	2SP												
	76 mm 3"	1.4	.054						2						
		1.4	.054						U2						
102 mm 4"	1.4	.054						3							
	1.4	.054						U3							
127 mm 5"	1.4	.054							4						
	1.4	.054							U4						
152 mm 6"	1.4	.054								4 ½					
	1.4	.054								5					
175 mm 7"	1.4	.054									5				
	1.4	.054									U5				
152 mm 6"	1.4	.054										6			
	1.4	.054										U6			
175 mm 7"	1.4	.054											7		
	1.4	.054											U7		

*Long Leg configuration is available. Allow for 25 mm (1") larger minimum pulley diameter.

	Unibar®
	Carded

Hook Abbreviations	
XSP	Extra Short Point
SP	Short Point
LP	Long Point
SL	Short Leg
LL	Long Leg

Fastener Ratings	
Hook Series	Operating Tension Range
25 Series	Up to 10.2 kN/m/60 PIW
36 Series	Up to 12.7 kN/m/75 PIW
1 (40) Series	Up to 12.7 kN/m/75 PIW
Regular (54) Series	Up to 21.2 kN/m/125 PIW

NOTE: Fastener ratings are subject to many variables including belt composition, age, speed, cycles, etc. These ratings are intended to serve as a general guide to determine appropriate applications.

CLIPPER®

Wire Hook System

Fasteners

All Fasteners are 300 mm (12") lengths.

NOTE: Additional sizes, lengths, and materials are available. Contact Flexco Customer Service if alternate fasteners are required for your application.

Unibar® Fasteners

UCM36 Unibar® (0.7 x 0.9 mm/.027" x .036" Wire Diameter)					
Metal	Pins	UCM36SLXSP	UCM36SLSP	UCM36XSP	UCM36SP
316SS	No	UCM36SLXSPSS12	UCM36SLSPSS12	UCM36XSPSS12	UCM36SPSS12
Metal	Pins	UCM36	UCM36LP	UCM36LLSP	UCM36LL
316SS	No	UCM36SS12	UCM36LPSS12	UCM36LLSPSS12	UCM36LLSS12

UX1 Unibar® (1.0 mm/.040" Wire Diameter)					
Metal	Pins	UX1SP	UX1	UX1LLSP	UX1LL
430SS	No	UX1SPS12	UX1S12	UX1LLSPS12	UX1LLS12
316SS	No	UX1SPSS12	UX1SS12	UX1LLSPSS12	UX1LLSS12

U2-U7 Unibar® (1.4 mm/.054" Wire Diameter)								
Metal	Pins	U2SP	U2	U3	U4	U5	U6	U7
Coated Steel™	No	U2SPC12	U2C12	U3C12	U4C12	U5C12	U6C12	
430SS	No	U2SPS12	U2S12	U3S12	U4S12	U5S12	U6S12	U7S12
316SS	No		U2SS12	U3SS12	U4SS12	U5SS12	U6SS12	

Carded Fasteners

25 Series (0.6 mm/.025" Wire Diameter)			
Metal	Pins	25	25LL
Galvanized	Yes	25G12NY	25LLG12NY
316SS	Yes	25SS12NYS	25LLSS12NYS

36 Series (0.7 mm high x 0.9 mm wide/.027" x .036" Wire Diameter)					
Metal	Pins	36SP	36	36LLSP	UCM36LL
316SS	No	36SPSS	36SS	36LLSPSS12	UCM36LLSS12

1 (40) Series (1.0 mm/.040" Wire Diameter)				
Metal	Pins	1XSP	1SP	1
Galvanized	Yes	1XSPG12NY	1SPG12NY	1G12NY
High Tensile	No	1XSPHT12	1SPHT12	1HT12
430SS	Yes	1XSPS12NYS	1SPS12NYS	1S12NYS
316SS	No	1XSPSS12	1SPSS12	1SS12

Regular (54) Series/2-7 (1.4 mm/.054" Wire Diameter)									
Metal	Pins	2SP	2	3	4	4½	5	6	7
Galvanized	Yes	2SPGNY	2GNY	3GNY	4GNY	4-1/2GNY	5GW	6GW	7GW
High Tensile	No	2SPHT	2HT	3HT	4HT	4-1/2HT	5HT	6HT	7HT
430SS	Yes	2SPSNYS	2SNYS	3SNYS	4SNYS	4-1/2SNYS	5SW	6SW	7SW
316SS	No	2SPSS	2SS	3SS	4SS	4-1/2SS	5SS	6SS	7SS

CLIPPER®

Wire Hook System

Connecting Pins

Connecting pins are the vital link that, when combined with properly selected and installed hooks, complete the perfect splice. A wide selection of materials and sizes lets you match a connecting pin to the special needs of your application.

Connecting Pin Types

- A. DuraStainless™ – DSS D. Nylostainless – NYS
 B. Duralink™ – DL E. Nylon-Covered-Cable – NCS
 C. Nylosteel - NY F. Nylon Plus – NP



Connecting Pin Specifications

Pin Diameter		Hook Size
mm	in.	
1.7	.065	25, 36, UCM36, 1, UX1
2.4	.093	2SP, 2, 3, UZSP-U3,
2.8	.109	4, U4
3.2	.125	4-1/2, 5, U5
4.0	.156	6, 7, U6, U7

Connecting Pin Characteristics

Connecting Pin Types	Available Sizes		Abrasion Resistance	Hook Loop Wear Resistance	Rigidity	Magnetic	Flexibility	Composition
	mm	in.						
DuraStainless™ (DSS)	1.7, 2.4, 2.8	.065, .093, .109	Excellent	Excellent	Good	Slightly	Good	Wear-resistant nylon & 300 Series Stainless spring wire
Duralink™ (DL)	1.7, 2.4, 2.8, 3.2	.065, .093, .109, .125	Excellent	Excellent	Average	Slightly	Excellent	Wear-resistant nylon & 300 Series Stainless cable
Nylosteel (NY)	1.4, 1.7, 2.0, 2.4, 2.8, 3.2, 4.0	.053, .065, .079, .093, .109, .125, .156	Good	Good	Good	Yes	Good	Nylon & music wire
Nylostainless (NYS)	1.4, 1.7, 2.0, 2.4, 2.8, 3.2, 4.0	.053, .065, .079, .093, .109, .125, .156	Good	Good	Good	Slightly	Good	Nylon & 300 Series Stainless spring wire
Nylon-Covered Cable (NCS)	1.7, 2.4, 3.2, 4.0	.065, .093, .125, .156	Good	Good	Average	Slightly	Excellent	Nylon & 300 Series Stainless cable
Nylon Plus (NP)	1.4, 1.7, 2.0, 2.4, 2.8, 3.2, 4.0	.053, .065, .079, .093, .109, .125, .156	Good	Excellent	Fair	No	Excellent	Nylon

CLIPPER®

Wire Hook System

Connecting Pins

Pin Pak™

Contains 30 M (100 ft.) of spooled connecting pin material. Available in most popular sizes and materials.



Pin Pak™ 30M/100ft				
Pin Diameter		Ordering Number		
mm	in.	Nylosteel	NyloStainless	Nylon Covered Cable
1.4	.053	NY053-C	NYS053-C	
1.7	.065	NY065-C	NYS065-C	NCS065-C
2.0	.079	NY079-C	NYS079-C	
2.4	.093	NY093-C	NYS093-C	NCS093-C
2.8	.109	NY109-C	NYS109-C	
3.2	.125	NY125-C	NYS125-C	NCS125-C
4.0	.156	NY156-C	NYS156-C	NCS156-C
		Nylon Plus	Duralink™	DuraStainless™
1.4	.053	NP053-C		
1.7	.065	NP065-C	DL065-C	DSS065-C
2.0	.079	NP079-C		
2.4	.093	NP093-C	DL093-C	DSS093-C
2.8	.109	NP109-C	DL109-C	DSS109-C
3.2	.125	NP125-C	DL125-C	
4.0	.156	NP156-C		

Also available in coils

Leader Assembly

Leader Assemblies simplify insertion of flexible Nylon Covered Cable (NCS) and Duralink™ (DL) pin materials into finished splices. The flexible pin is attached to a smaller diameter, rigid music wire which leads the flexible pin through the splice with ease. A convenient and time-saving advantage for wider belts.

Leader Assembly							
Diameter		Material	Cable Length		Leader Length		Ordering Number
mm	in.		M	Foot	M	Foot	
1.7	.065	Nylon Covered Cable	3	10	3	10	NCS065X10FT-W/10FT
1.7	.065	Nylon Covered Cable	7.5	25	7.5	5	NCS065X25FT-W/5FT
2.4	.093	Nylon Covered Cable	1.5	5	1.5	5	NCS093X5FT-W/5FT
2.4	.093	Nylon Covered Cable	3	10	3	10	NCS093X10FT-W/10FT
2.4	.093	Nylon Covered Cable	4.5	15	4.5	2	NCS093X15FT-W/2FT
2.4	.093	Nylon Covered Cable	7.5	25	7.5	5	NCS093X25FT-W/5FT
2.4	.093	Nylon Covered Cable	7.5	25	7.5	10	NCS093X25FT-W/10FT
2.4	.093	Nylon Covered Cable	15.2	50	15.2	4	NCS093X50FT-W/4FT
1.7	.065	Duralink™	7.5	25	7.5	5	DL065X25FT-W/5FT
2.4	.093	Duralink™	3	10	3	10	DL093X10FT-W/10FT
2.4	.093	Duralink™	7.5	25	7.5	5	DL093X25FT-W/5FT



Leader Assemblies allow the connecting pin to be pulled through with ease. The leader is then cut off and discarded.

Duralink™ and DuraStainless™ Connecting Pins

Extend pin life with Duralink™ or DuraStainless™ connecting pins. Both provide ten times more abrasion resistance than standard nylon-covered pins. The proprietary, filled-nylon coating offers high abrasion resistance and higher lubricity for greater pin wear and fastener loop wear. Select Duralink, with the braided stainless cable core, for applications requiring a flexible pin (i.e. crowned pulleys or troughed conveyors). Or, select DuraStainless, with the solid stainless core, for greater rigidity and ease of pin insertion.



CLIPPER®

Wire Hook System

Maintenance Lacers

A key advantage of the wire hook system is that the fasteners are machine-installed, yielding a precise, strong and smooth splice. Clipper® offers several different lacers to match a variety of on-site, production or special application lacing needs. All lacers are designed with durability and speed-of-installation features built into them.

Roller Lacer® Gold Class™

A power-assisted lacer designed to reduce installation time and operator fatigue. Available in four widths: 600, 900, 1200, 1500 mm (24", 36", 48", and 60"). Ideal for larger operations with wide belts. Unmatched speed and ease of use.

- Lacer is driven by a user's cordless drill (18 volt or higher), reducing installation time by 35%. A manual drive handle is supplied for use if the drill has lost its charge.
- Belt Support Shelf easily guides belt into the hook points, reducing operator time and effort.
- Handle-actuated belt clamp system.
- Sturdy aluminum construction for on-site installation.
- Storage compartment for extra face strips and lacer pins.
- Continuous lacing feature for lacing belts wider than the tool's width.



**Drill not included with sale of lacer.*

Roller Lacer® Gold Class™		
Belt Width		Ordering Number
mm	in.	
600	24	RL-G24
900	36	RL-G36
1200	48	RL-G48
1500	60	RL-G60

Face Strips sold separately

Roller Lacer® Gold Class™ Face Strips					
Belt Width		Ordering Number			
mm	in.	Hook Size UCM36, 36	Hook Size UX1, 1	Hook Size U2-U3, 2-4	Hook Size U4-U7, 4 1/2-7
600	24	FSGOLD36-24	FSGOLD1-24	FSGOLD2-24	FSGOLD4-1/2-24
900	36	FSGOLD36-36	FSGOLD1-36	FSGOLD2-36	FSGOLD4-1/2-36
1200	48	FSGOLD36-48	FSGOLD1-48	FSGOLD2-48	FSGOLD4-1/2-48
1500	60	FSGOLD36-60	FSGOLD1-60	FSGOLD2-60	FSGOLD4-1/2-60

Includes one Lacer Pin

CLIPPER® Wire Hook System

Maintenance Lacers

Roller Lacer®

Available in four widths: 600, 900, 1200, 1500 mm (24", 36", 48", and 60"). Ideal for users with wide belts requiring on-site installation.

- Handle-actuated belt clamp system
- Sturdy aluminum construction for on-site installation
- Storage compartment for extra face strips and lacer pins
- Continuous lacing feature for lacing belts wider than the tool's width



Roller Lacer®		
Belt Width		Ordering Number
mm	in.	
600	24	RL-24
900	36	RL-36
1200	48	RL-48
1500	60	RL-60

Face Strips sold separately

Roller Lacer® Face Strips					
Belt Width		Hook Size UCM36, 36	Hook Size UX1, 1	Hook Size U2-U3, 2-4	Hook Size U4-U7, 4½-7
mm	in.				
600	24	FSMAN36-24	FSMAN1-24	FSMAN2-24	FSMAN4-1/2-24
900	36	FSMAN36-36	FSMAN1-36	FSMAN2-36	FSMAN4-1/2-36
1200	48	FSMAN36-48	FSMAN1-48	FSMAN2-48	FSMAN4-1/2-48
1500	60	FSMAN36-60	FSMAN1-60	FSMAN2-60	FSMAN4-1/2-60

Includes one Lacer Pin

Microlacer®

Proven, reliable choice for belts 350 mm (14") wide and less. Can also be used on wider belts with infrequent lacing requirements.

- Belts are secured by tightening belt clamp knobs
- Sturdy construction
- Compact and lightweight
- Economical
- Continuous lacing feature for lacing belts wider than the tool's width



Microlacer®		
Belt Width		Ordering Number
mm	in.	
350	14	MICROLACER

Face Strips sold separately

Microlacer® Face Strips	
Hook Size	Ordering Number
UCM36, 36	FSMAN36-MICRO
UX1, 1	FSMAN1-MICRO
U2-U3, 2-4	FSMAN2-MICRO
U4-U7, 4½-7	FSMAN4-1/2-MICRO

Includes one Lacer Pin

Clipper® Roller Lacing Technology™

The advantages of lacer installation and Clipper® Roller Lacing Technology™ are what set Clipper wire hook systems apart from all other light-duty fasteners.

All three maintenance lacers – the Roller Lacer® Gold Class™, the Roller Lacer and the Microlacer® – utilize Roller Lacing Technology.

Clipper Roller Lacing Technology works fast to significantly minimize downtime, without sacrificing precision.

One person can install splices on-site and the process is easy to learn. The lacers are lightweight, portable, and easy-to-carry. Sturdy aircraft aluminum construction can handle rigorous use.



CLIPPER®

Wire Hook System

Production Lacers

Production Lacers are designed for high-volume production lacing. It's the quickest, most precise method of installing wire hooks. As the lacer jaws contact the hooks, the hook points penetrate the belt at the ideal angle, resulting in an optimal splice. Hook retainers/combs are available for all sizes of hooks, making production lacers capable of lacing any size Clipper® hook. All production lacers offer the continuous lacing feature which, with multiple operations, allows the user to lace belts wider than the width of the lacer.

Pro 6000

Users of the hydraulic Pro 6000 install the ultimate splice. The jaws can be heated to ease hook penetration and to allow the belt cover to slightly flow, resulting in a splice with an extremely low profile. Lace 350 mm (14") at a time, with combs available in lengths up to 1500 mm (60"). Longer combs allow the user to first load the fasteners into the comb, then lace up to 300 mm (12") at a time, sliding the comb to the next section to be laced.

Lacer pressure can be adjusted up to 500 bar (7350 PSI), jaw closure hold time up to 10 seconds, and heated jaws up to 200° C (390° F).

Electronic controls permit users to program heat, pressure, and jaw closure times for repeatability in lacing procedures.

Pro 600

Includes all Pro 6000 features except the heated jaws.

Electric Hydraulic Lacer

No better choice for users who insist on speed. Available in 300, 625, and 950 mm (12", 25", and 38") models.

- Laces entire lacer width with one simple press of the foot pedal
- Continuous lacing feature
- Suitable for both shop and production use

The Pro Series

Pro Series production lacers feature our patented jaw action – the comb, hooks and belt are simultaneously pulled down as the jaws compress the hooks into the belt, forming an optimal hook profile.



Shown: Pro 6000

Pro 600 & Pro 6000 Lacer	
Ordering Number	
PRO-600	
PRO-6000	

Combs sold separately

Combs for Pro 600 & Pro 6000 Lacer					
Belt Width		Ordering Number			
mm	in.	Hook Size 25	Hook Size 36, UCM36, 30	Hook Size 1, UX1	Hook Size 2-7, U2-U7
600	24	P6CLPR25M-24	P6CLPR36M-24	P6CLPR1M-24	P6CLPR2M-24
900	36	P6CLPR25M-36	P6CLPR36M-36	P6CLPR1M-36	P6CLPR2M-36
1200	48	P6CLPR25M-48	P6CLPR36M-48	P6CLPR1M-48	P6CLPR2M-48
1500	60	P6CLPR25M-60	P6CLPR36M-60	P6CLPR1M-60	P6CLPR2M-60

Includes one Lacer Pin

Electric Hydraulic Lacer		
Belt Width		Ordering Number
mm	in.	
300	12	EH-12
625	25	EH-25
950	38	EH-38

Includes #2-7 Retainer

NOTE: Please specify 115 or 230 volt wiring requirements when ordering. Can be ordered for international requirements.



Hook Retainer for Hydraulic Lacers					
Belt Width		Ordering Number			
mm	in.	Hook Size 25	Hook Size 36, UCM36, 30	Hook Size 1, UX1	Hook Size 2-7, U2-U7
300	12	HR25-12	HR36-12	HR1-12	HRREG-12
625	25	HR25-25	HR36-25	HR1-25	HRREG-25
950	38	HR25-38	HR36-38	HR1-38	HRREG-38

Includes one Lacer Pin

CLIPPER®

Wire Hook System

Production Lacers

#12 Speed Lacer

The most economical production lacing tool. It is a durable, shop-use lacer for hooks of all sizes.

- Manually operated
- Laces 300 mm (12") at a time
- Continuous lacing feature
- Optional chain drive attachment is available to prevent closing lever from interfering with wide belts

#12 Speed Lacer		
Belt Width		Ordering Number
mm	in.	
300	12	12LACER
Chain Drive Attachment		
12LACER-CHAIN		

Includes #2-7 Retainer

Hook Retainer for #12 Speed Lacer	
Hook Size	Ordering Number
25	HR25-12
30, 36, UCM36	HR36-12
1, UX1	HR1-12
2-7, U2-U7	HR2-12

Includes one Lacer Pin



Specialty Lacers

Vise Lacers

The reliable Vise Lacer is the most economical method of installing Clipper® hooks.

- Fits into any shop vise
- Ideal for the user with few belts
- Continuous lacing feature

Vise Lacers	
Hook Size	Ordering Number
2-7, U2-U7	R-4
2-7, U2-U7	R-7
2-7, U2-U7	R-10
1, UX1	1VL-7
30, 36, UCM36	36VL-7
25	25VL-7

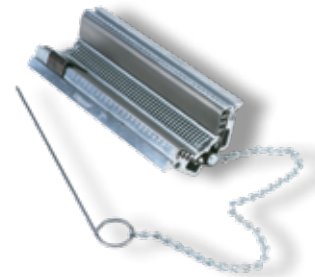

LW95

Portable unit laces up to 150 mm (6") in one operation.

- Continuous lacing feature
- Hook retainers available for all hook sizes

LW95 Lacers	
Hook Size	Ordering Number
2-7, U2-U7	LW95
1, UX1	1LW95
25	25XLW

Hook Retainer for LW95 Lacers	
Hook Size	Ordering Number
2-7, U2-U7	HR2LW95
1, UX1	HR1LW95
30, 36, UCM36	HR36LW95
25	HR25LW95

Includes one Lacer Pin



CLIPPER® Wire Hook System

Belt Preparation Tools

900 Series/845LD Belt Cutters

The Flexco belt cutters incorporate numerous features for easy, smooth cutting of belts with extreme accuracy.

- Durable blade design that produces highly accurate cuts while being fully enclosed for safety
- Quick belt clamp feature
- 900 Series cuts belts up to 38 mm (1-1/2")
- 845LD cuts belts up to 12 mm (1/2") thick

350 mm (14") Belt Cutter

Portable tool cuts belts up to 350 mm (14") wide, quickly and easily.

- Cuts belts up to 9.5 mm (3/8") thick

SmartClamp™ Belt Clamps

The SmartClamp™ system provides both safety and efficiency when clamping belts for installation of mechanical belt fasteners. The fast setup saves costly downtime during a breakdown situation while the smooth transition from clamp to belt reduces the chance of belt damage.

Laser Belt Square

The Laser Belt Square makes the process of squaring a belt for splicing fast, easy, and accurate. The Laser Belt Square is perfect for use in multiple light-duty applications, including tight spaces and belts with side pans.

Rough Top Belt Skiver

Simplifies removal of belt impression covers prior to fastener size selection and installation.

RB-1 Belt Grinder

Carbide cuts belt impression cover for quick and clean skiving. Attaches to a 10 mm (3/8") electric or pneumatic drill (2,500 rpm).



900 Series Belt Cutter



845LD Belt Cutter



350 mm (14") Belt Cutter



Smart Clamp™ Belt Clamps



Laser Belt Square

900 Series* Belt Cutter		
Belt Width		Ordering Number
mm	in.	
600	24	900924
900	36	900936
1200	48	900948
1500	60	900960
1800	72	900972
2100	84	900984
845LD Series Belt Cutter		
900	36	845836LD
1200	48	845848LD
1500	60	845860LD
1800	72	845872LD

* Patent pending

350 mm (14") Belt Cutter		
Belt Width		Ordering Number
mm	in.	
350	14	CUTTER-14

Smart Clamp™ Belt Clamps	
Ordering Number	
SMARTCLAMP	

Laser Belt Square	
Ordering Number	
LASER-BELT-SQUARE	

Rough Top Belt Skiver	
Ordering Number	
RTBS	

RB-1 Belt Grinder	
Ordering Number	
RB-1	

Authorised Distributor: