

MMP

Medium-Duty Precleaner

Extra Cleaning Power for Tough Jobs

The MMP Medium-Duty Precleaner tackles those tough applications where the standard-duty precleaner is not sturdy enough but the heavy-duty cleaner is overkill. The MMP is built tough with a heavy-duty pole, a larger, powerful blade and a beefy dual tensioning system. Yet installation is simple, maintenance is quick, and bottom line – the cleaning job is excellent.

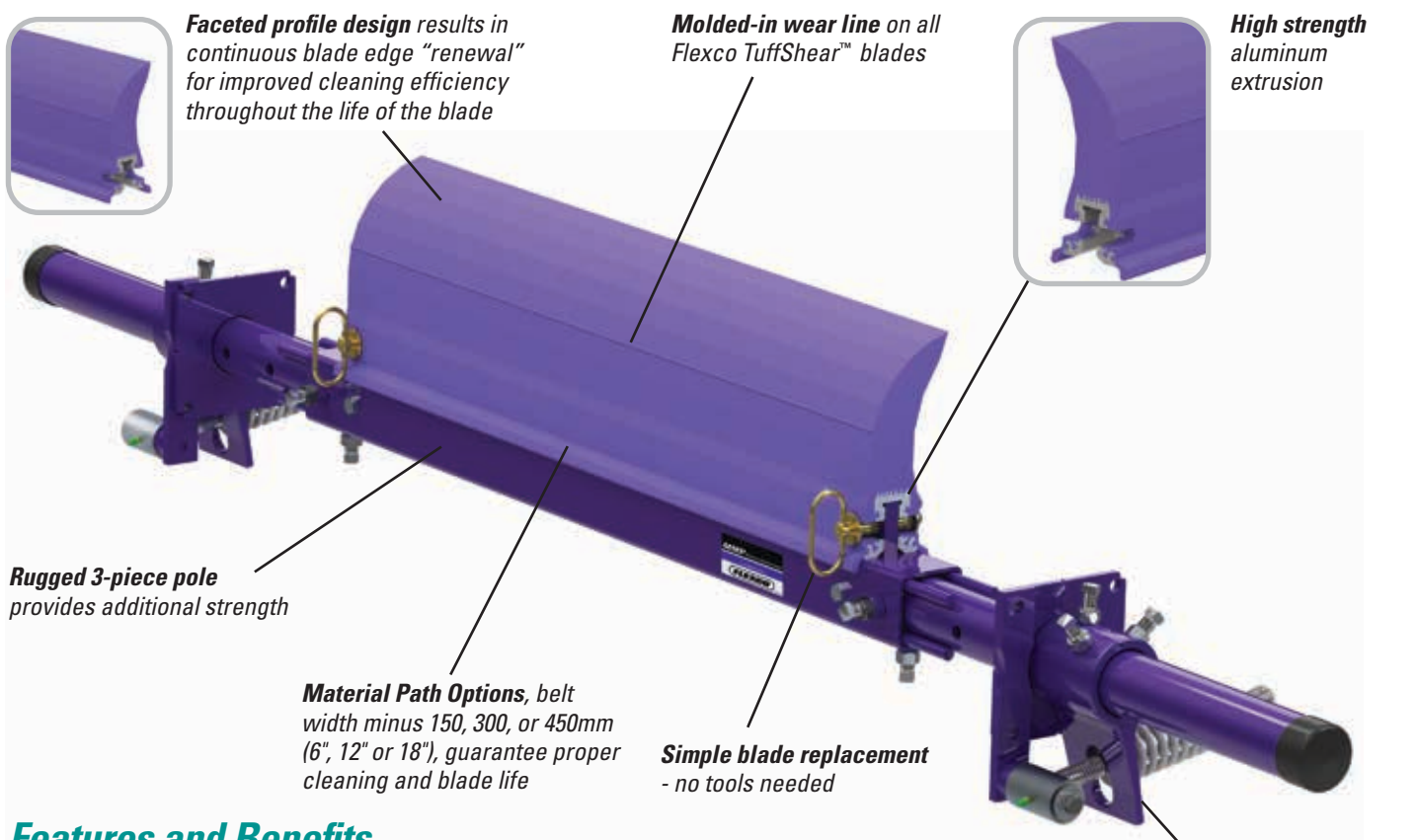

Features and Benefits

- **Compact and versatile.** Requires only 100mm (4") of horizontal clearance for installation. Pole length is belt width plus 1350mm (54") to fit varying conveyor or chute wall widths. Pole extenders are available for extended length requirements.
- **Works with Flexco and other mechanical splices.** The spring tensioner quickly moves the blade away from the belt when a splice passes. The polyurethane blade easily glides over the splice without damage and with minimal cleaning disruption.
- **Made for mining conveyors.** Made from heavy-duty steel with corrosion-resistant powder coating, the MMP is available for belt widths from 600 to 2400 mm (24" to 96"). Special sizes are available upon request.
- **Complete cleaning system.** When teamed with our MHS Secondary Cleaner, it makes up a system that delivers maximum cleaning power. If extra water is present, the MDWS DryWipe can be added.



MMP Medium-Duty Precleaner

Specifications and Guidelines

- **Maximum Belt Speed**
5 m/s (1000 FPM)
- **Temperature Rating**
-35°C to 82°C (-30°F to 180°F)
- **Minimum Pulley Diameter**
400mm (16")
- **Blade Height**
250mm (10")
- **Usable Blade Wear Length**
150mm (6")
- **Blade Material**
Polyurethane 83 durometer (proprietary blend for abrasion resistance and long wear)
- **Available for Belt Widths**
600 to 2400mm (24" to 96")
- **Horizontal Clearance Required**
100mm (4")
- **Vertical Clearance Required**
325mm (13")
- **Pole Length**
Cleaner size + 1350mm (54")
- **Maximum Conveyor Span**
Cleaner size + 1050mm (42")

Pole Location Specs

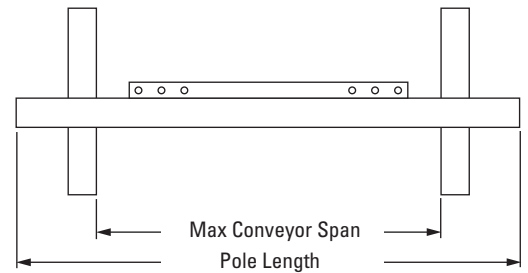
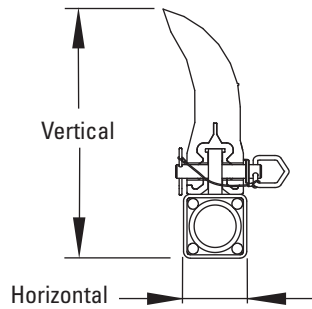
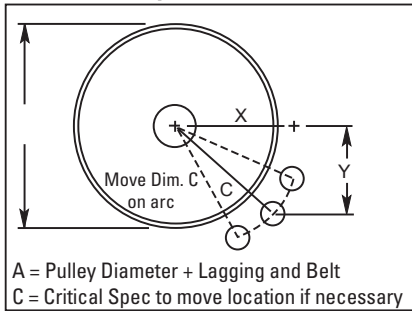

Pole Location Chart

A	X	Y	C	A	X	Y	C	A	X	Y	C
400	206	305	368	675	359	305	470	950	502	305	587
425	222	305	378	700	371	305	479	975	518	305	600
450	235	305	384	725	387	305	492	1000	527	305	610
475	248	305	394	750	397	305	502	1025	543	305	622
500	264	305	403	775	410	305	511	1050	552	305	632
525	279	305	413	800	425	305	524	1075	568	305	645
550	292	305	422	825	438	305	533	1100	578	305	654
575	305	305	432	850	451	305	543	1125	594	305	667
600	321	305	441	875	464	305	556	1150	606	305	679
625	333	305	451	900	476	305	565	1175	619	305	689
650	346	305	460	925	492	305	578	1200	632	305	702

Ordering Information

MMP Precleaner - Belt Width Minus 150mm (6")					
Belt Width	Blade Width	Ordering	Item		
mm	in.	Number	Code		
600	24	450	18	MMP600-150	81137
750	30	600	24	MMP750-150	81138
900	36	750	30	MMP900-150	81139
1050	42	900	36	MMP1050-150	81140
1200	48	1050	42	MMP1200-150	81141
1350	54	1200	48	MMP1350-150	81142
1500	60	1350	54	MMP1500-150	81143
1800	72	1650	66	MMP1800-150	81144
2100	84	1950	78	MMP2100-150	81145
2400	96	2250	90	MMP2400-150	-

MMP Precleaner - Belt Width Minus 300mm (12")

Belt Width	Blade Width	Ordering	Item		
mm	in.	mm	mm	Number	Code
750	30	450	450	MMP750-300	81146
900	36	600	600	MMP900-300	81147
1050	42	750	750	MMP1050-300	81148
1200	48	900	900	MMP1200-300	81149
1350	54	1050	1050	MMP1350-300	81150
1500	60	1200	1200	MMP1500-300	81151
1800	72	1500	1500	MMP1800-300	81152
2100	84	1800	1800	MMP2100-300	81153
2400	96	2100	2100	MMP2400-300	-

TuffShear™ Replacement Blades

Blade Width	Ordering	Item		
mm	in.	Number	Code	
450	18	TRB18	76485	
600	24	TRB24	76486	
750	30	TRB30	76487	
900	36	TRB36	76488	
1050	42	TRB42	76489	
1200	48	TRB48	76490	
1350	54	TRB54	76491	
1500	60	TRB60	76492	
1650	66	TRB66	76493	
1800	72	TRB72	76494	
1950	78	TRB78	76697	
2100	84	TRB84	77047	
2250	90	TRB90	77048	

Other blade sizes available upon request.

Authorized Distributor:

240 Macpherson Road • #02-01 • Singapore 348574
Tel: +65-6484-1533 • Fax: +65-6484-1531 • E-mail: asiasales@flexco.com

Visit www.flexco.com for other Flexco locations and products.

©2020 Flexible Steel Lacing Company. 05/11/20. For reorder: X5053

