

FGP Flange Bearing Mount (56586)

Instructions

1. Reference FGP Food Grade Precleaner IOM (X3646) for full installation details. This sheet is only to guide the installation of the optional mounting bracket.

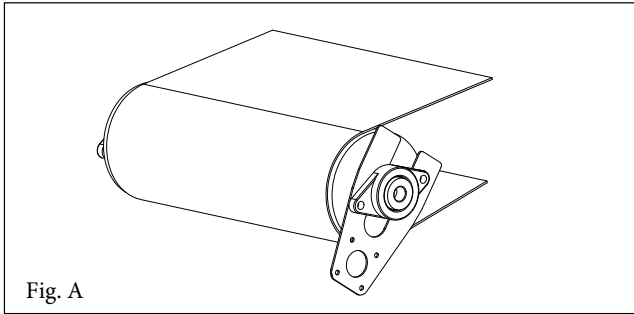

2. Position first bracket so FGP Pole center is at correct XYZ position (Fig. A).

3. Trim bracket as necessary, then temporarily clamp or tack-weld bracket in place. This will allow for future adjustments.

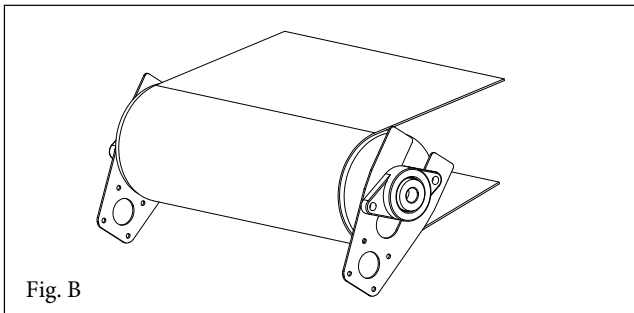

4. Temporarily mount 2nd bracket onto the opposite side of conveyor (Fig. B).

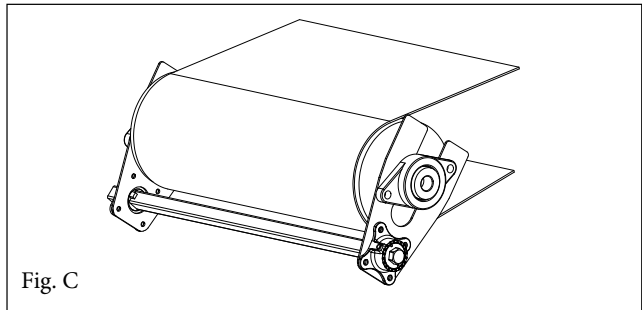

5. Test fit cleaner without blade. Pole should be parallel to the pulley (Fig. C).

6. If the pole is in the correct position, then permanently affix brackets using one of the following options:

- Drill thru-holes through bearing block and use bearing bolts to secure brackets
- Weld brackets to conveyor structure
- Bolt to conveyor structure using separate bolts

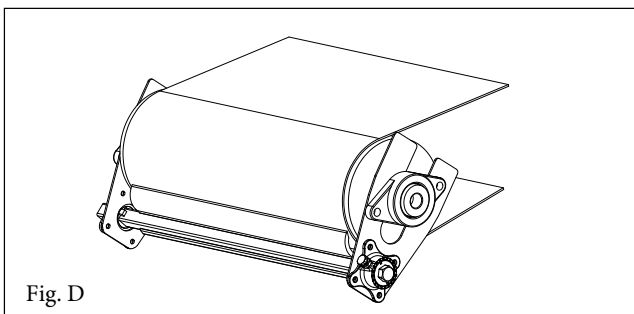

7. Install cleaner and tension blade appropriately (Fig. D).



2525 Wisconsin Avenue • Downers Grove, IL 60515-4200 U.S.A.
Telephone: 1-630-971-0150 • Fax: 1-630-971-1180 • E-mail: info@flexco.com

Visit www.flexco.com for other Flexco locations and products.

©2018 Flexible Steel Lacing Company. 02-28-18. For Reorder: X5014

