

H-Type® High-Temp Precleaner with V-Tips

Vulcanized Clinker Belts, High Temp Precleaner

The Flexco H-Type® Precleaner with High Temperature V-Tips is designed to be positioned on the head pulley and to remove the bulk of the carryback from the belt. It has the ability to withstand ambient temperatures up to 204° C (400° F) and spikes up to 232° C (450° F). Proven performance over 20 years as the most efficient primary cleaner for vulcanized belts carrying abrasive clinker in high heat cement applications.

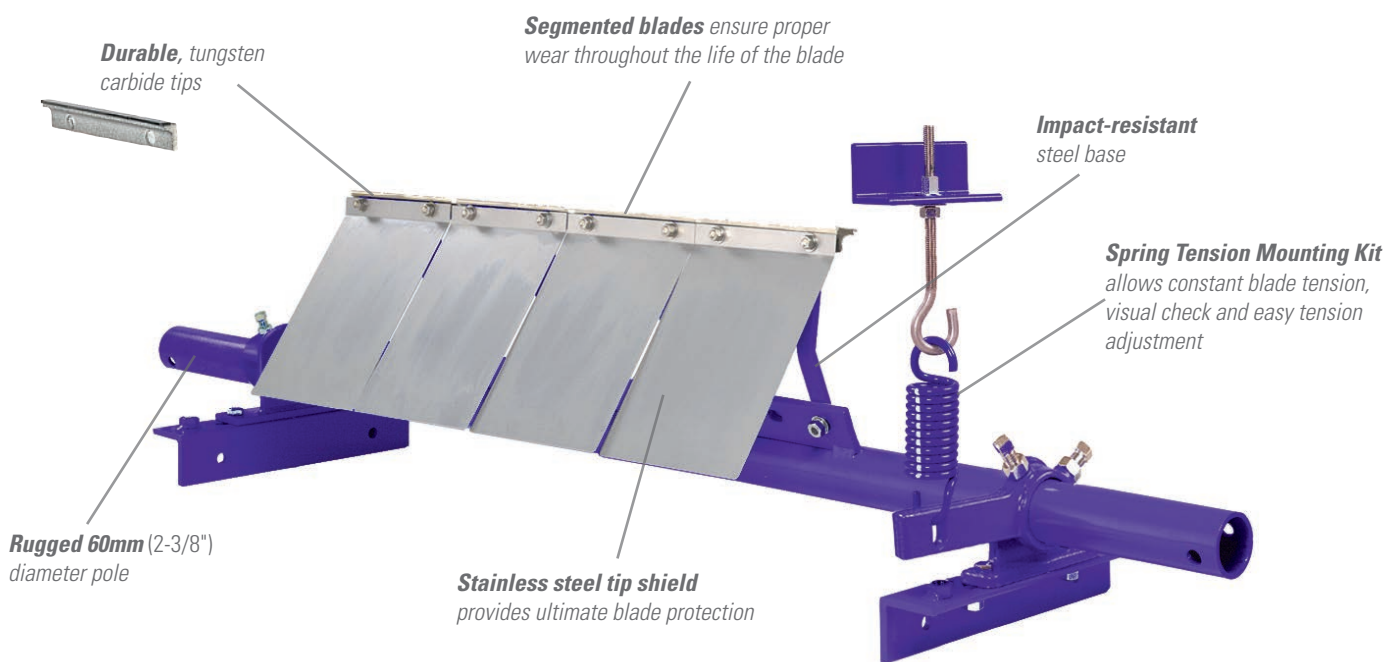

Features and Benefits

- **Works with vulcanized belts.** The tungsten carbide tips allow for maximum cleaning efficiency and superior wear characteristics. Comes with protected tips for abrasive applications.
- **Complete cleaning system.** When teamed with a secondary cleaner, it makes up a system that delivers maximum cleaning power for the most abusive conveyor applications.
- **Made for mining conveyors.** Made from heavy-duty steel with corrosion-resistant powder coating, the H-Type® is available in sizes for belt widths from 450 to 1200mm (18" to 48"). Additional sizes are available upon request.
- **Optimal positioning.** Blade contact on the pulley is 15° below the horizontal centerline. This keeps the blades out of the discharge path and protects them from rocks, large lumps and other debris.

H-TYPE[®]

High-Temp Precleaner with V-Tips

Specifications and Guidelines

Maximum Belt Speed

5 m/s (1000 FPM)

Temperature Rating

-35° C to 204° C (-30° F to 400° F)
spikes up to 232° C (450° F)

Minimum Pulley Diameter

200 mm (8")

Usable Blade Wear Length

9 mm (3/8")

Blade Material

Tungsten carbide (for vulcanized belts only)

Available for Belt Widths

450 to 1200 mm (18" to 48")

CEMA Cleaner Rating

Class 3

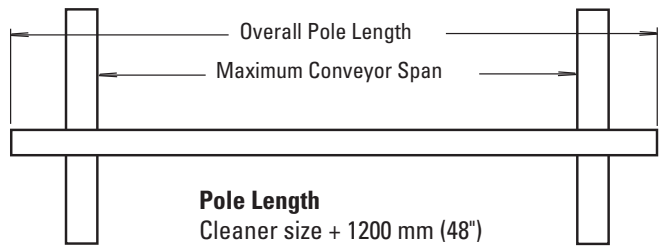

Pole Length

Cleaner size + 1200 mm (48")

Maximum Conveyor Span

Cleaner size + 950 mm (38")

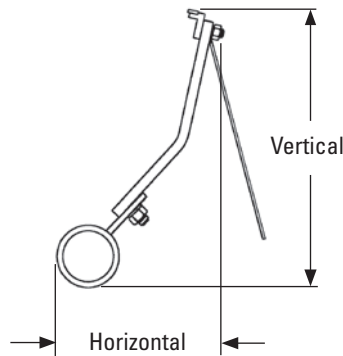

Horizontal Clearance Required

175 mm (7")

Vertical Clearance Required

SS: 325 mm (13")

S: 375 mm (15")

M: 413 mm (16-1/2")

Ordering Information

High Temp Precleaner with V-Tips

Belt Width	Suspension Arm Size	Ordering Number	Item Code
mm	in.		
450	18	SS	HTV18SS 74821
450	18	S	HTV18S 74828
600	24	SS	HTV24SS 74822
600	24	S	HTV24S 74829
750	30	SS	HTV30SS 74823
750	30	S	HTV30S 74830
900	36	SS	HTV36SS 74824
900	36	S	HTV36S 74831
900	36	M	HTV36M 74838
1050	42	SS	HTV42SS 74825
1050	42	S	HTV42S 74832
1050	42	M	HTV42M 74839
1200	48	SS	HTV48SS 74826
1200	48	S	HTV48S 74833
1200	48	M	HTV48M 74840

Suspension arm size is determined by head pulley diameter- see chart.

Pole Diameter - 60mm (2-3/8")

Lead time: 1 working day

Suspension Arm Size

Head Pulley Diameter + Belt & Lagging		Suspension Arm Size
mm	in.	
200 - 375	8 - 15	SS
400 - 675	16 - 27	S
700 - 875	28 - 35	M

Replacement V-Tips

Ordering Number	Item Code
HVT8-S/S	75419

Lead time: 1 working day

Replacement Suspension Arms

Suspension Arm Size	Ordering Number	Item Code
SS	HSA8SS	73047
S	HSA8S	73048
M	HSA8M	73049

Lead time: 1 working day

Authorized Distributor: