

# Y-Type™ Polyurethane and Carbide Secondary Cleaner

## Simple, Effective Cleaning for Cement Operations Where Dust is Widespread

The Y-Type™ Secondary Cleaner should be installed throughout the cement process, especially in areas such as the materials storage and proportioning and finish mills, where dust is widespread. With easy, do-it-yourself installation and simple, serviceable blades, all at an affordable price, it makes for the ideal solution to facilitate the capture of usable materials.

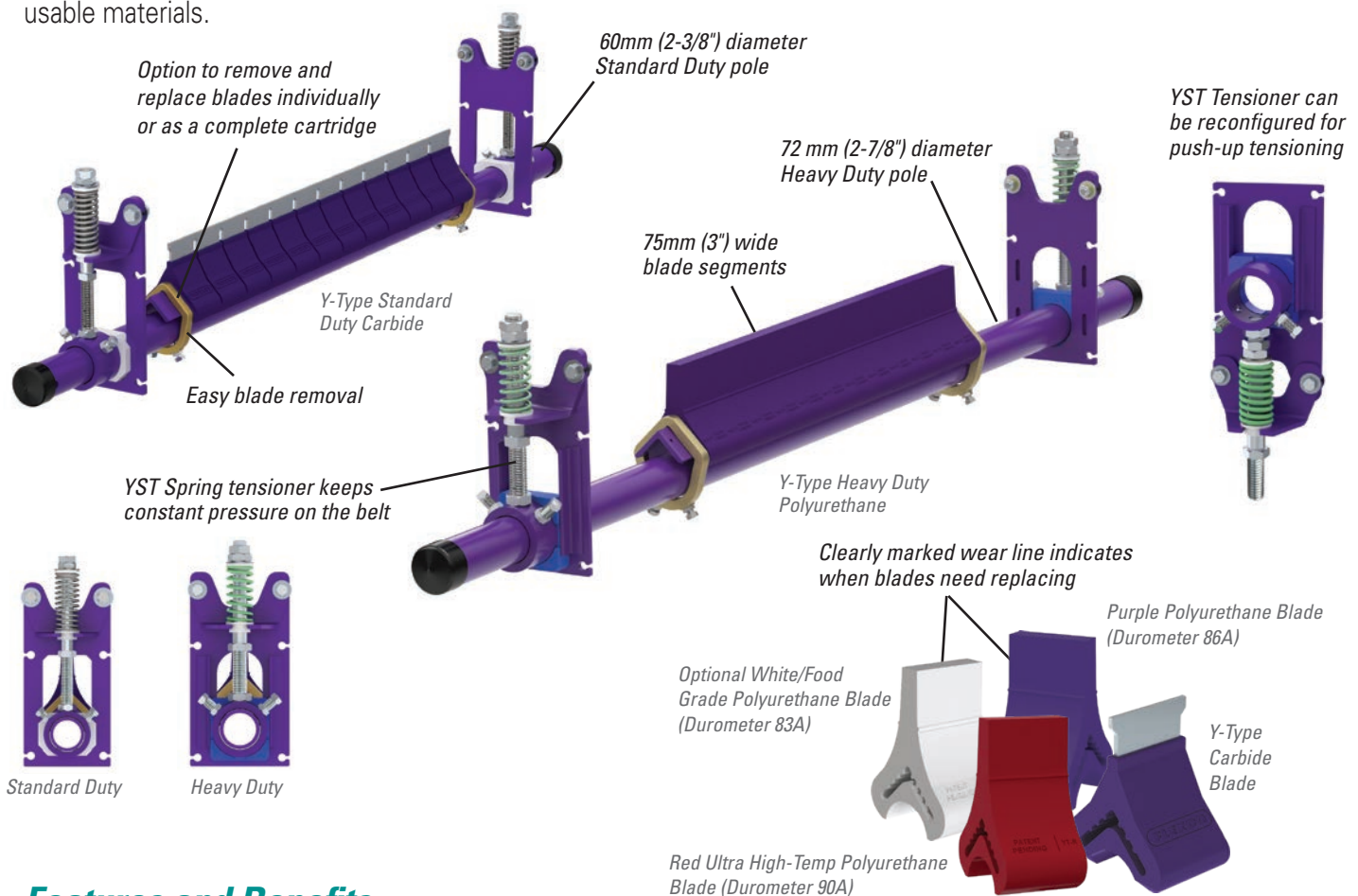

### Features and Benefits

- Belt speeds up to 3 m/s (600 fpm) for standard duty, up to 3.8 m/s (750 fpm) for heavy duty.
- Works on reversing belts.
- Available in 450 - 1200mm (18" - 48") for standard duty belts, 900 - 1800mm (36" - 72") for heavy duty belts .
- 75mm (3") wide blade segments. Conforms to worn or damaged belts.
- Blades available in carbide and purple or white/food grade polyurethane.
- **Easy maintenance.** Simple design makes changing the blades fast and easy. Blades can be removed and replaced individually, or all at once by replacing the cartridge.
- **Spring tensioner.** Utilizes the YST tensioner to maintain constant pressure on the belt. Standard duty YST for 60mm (2-3/8") poles, heavy duty YST for 73mm (2-7/8") poles.

# Y-Type™ Polyurethane and Carbide Secondary Cleaner

## Specifications and Guidelines

	Standard Duty	Heavy Duty
<b>Maximum Belt Speed</b>	3 m/s (600 FPM)	3.8 m/s (750 FPM)
<b>Temperature Rating</b>	Purple, White, Carbide: -35° C to 82° C (-30° F to 180° F) Red UHT: up to 200° C (400° F) with spikes to 232° C (450° F)	
<b>Usable Blade Wear Length</b>	Polyurethane: 50 mm (2")	Polyurethane: 75 mm (3")
	Carbide: 6 mm (1/4")	Carbide: 10 mm (3/8")
<b>Available for Belt Widths</b>	450 to 1200 mm (18" to 48")	900 to 1800 mm (36" to 72")

### Blade Material

Purple: Polyurethane (proprietary blend for abrasion resistance and long wear)

White: Polyurethane (chemical resistant/food grade)\*

Red: Polyurethane (ultra high-temp)

Carbide: Impact resistant tungsten carbide

\*All ingredients used in polyurethane formulation comply with the relevant requirements of 21 CFR (FDA Code of Federal Regulations) for use in repeated bulk dry food applications.

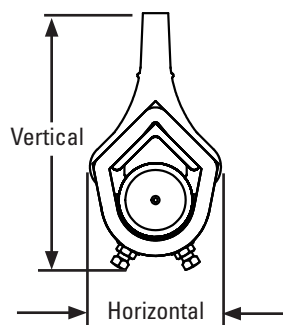

### Horizontal Clearance Required

**Standard Duty:** 110 mm (4-1/4")

**Heavy Duty:** 135 mm (5-1/4")

### Vertical Clearance Required

**Standard Duty:**

Polyurethane: 210 mm (8-1/4")

Carbide: 185mm (7-3/4")

**Heavy Duty:**

Polyurethane: 240 mm (9-1/2")

Carbide: 250 mm (9-3/4")

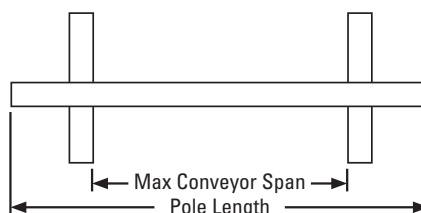

### Pole Length

SD Belt width + 762 mm (30")

HD Belt width + 1372 mm (54")

### Maximum Conveyor Span

SD Belt width + 559 mm (22")

HD Belt width + 1169 mm (46")

## Ordering Information

### Y-Type Secondary Cleaners - Standard Duty

Belt Width		Carbide Blades		Purple Polyurethane Blades		White/Food Grade Polyurethane Blades		Red/Ultra High-Temp Polyurethane Blades	
mm	in.	Ordering Number	Item Code	Ordering Number	Item Code	Ordering Number	Item Code	Ordering Number	Item Code
450	18	YT-TC-18S	79759	YT-18S	79765	YTW-18S	79771	YTR-18S	91798
600	24	YT-TC-24S	79760	YT-24S	79766	YTW-24S	79772	YTR-24S	91799
750	30	YT-TC-30S	79761	YT-30S	79767	YTW-30S	79773	YTR-30S	91800
900	36	YT-TC-36S	79762	YT-36S	79768	YTW-36S	79774	YTR-36S	91801
1050	42	YT-TC-42S	79763	YT-42S	79769	YTW-42S	79775	YTR-42S	91802
1200	48	YT-TC-48S	79764	YT-48S	79770	YTW-48S	79776	YTR-48S	91803

Lead time: 1 working day

### Y-Type Secondary Cleaners - Heavy Duty

Belt Width		Carbide Blades		Purple Polyurethane Blades		White/Food Grade Polyurethane Blades		Red/Ultra High-Temp Polyurethane Blades	
mm	in.	Ordering Number	Item Code	Ordering Number	Item Code	Ordering Number	Item Code	Ordering Number	Item Code
900	36	YTHD-TC-36S	79777	YTHD-36S	79783	YTHDW-36S	79789	YTHDR-36S	91816
1050	42	YTHD-TC-42S	79778	YTHD-42S	79784	YTHDW-42S	79790	YTHDR-42S	91817
1200	48	YTHD-TC-48S	79779	YTHD-48S	79785	YTHDW-48S	79791	YTHDR-48S	91818
1350	54	YTHD-TC-54S	79780	YTHD-54S	79786	YTHDW-54S	79792	YTHDR-54S	91819
1500	60	YTHD-TC-60S	79781	YTHD-60S	79787	YTHDW-60S	79793	YTHDR-60S	91820
1800	72	YTHD-TC-72S	79782	YTHD-72S	79788	YTHDW-72S	79794	YTHDR-72S	91821

Lead time: 1 working day

### Blades Required per Cleaner Size - Standard

mm	450	600	750	900	1050	1200
in.	18	24	30	36	42	48
<b>Blades Required</b>	6	8	10	12	14	16

### Blades Required per Cleaner Size - HD

mm	900	1050	1200	1350	1500	1800
in.	36	42	48	54	60	72
<b>Blades Required</b>	12	14	16	18	20	24

Authorized Distributor:

New Door No. 51 • Anna Salai, Nagalkeni • Pammal Village • Chennai - 600 044 • Tamil Nadu • India

Tel: +91-44-4856-6762 • E-mail: info.india@flexco.com

Visit [www.flexco.com](http://www.flexco.com) for other Flexco locations and products.

©2021 Flexible Steel Lacing Company. 10/28/21. For reorder: X4797

