

# PT Smart™ Belt Trainer

---

## Installation, Operation and Maintenance Manual

---

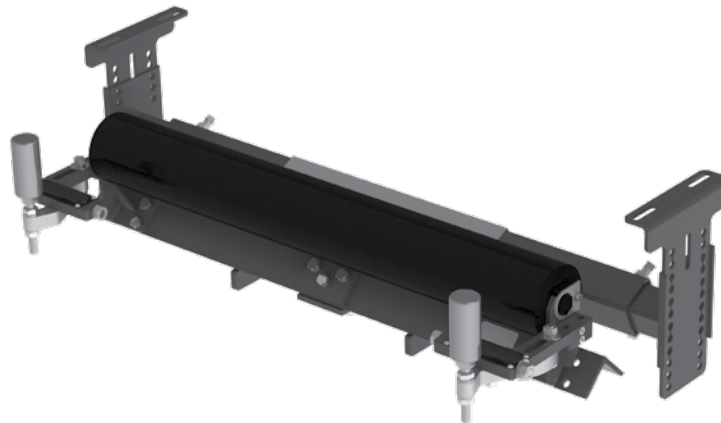

# PT Smart™ Belt Trainer

---

Purchase Date: \_\_\_\_\_

Purchased From: \_\_\_\_\_

Installation Date: \_\_\_\_\_

This information will be helpful for any future inquiries or questions about belt cleaner replacement parts, specifications or troubleshooting.

# Table of Contents

---

<b>Section 1 - Important Information .....</b>	<b>4</b>
1.1 General Introduction .....	4
1.2 User Benefits .....	4
1.3 Proper Belt Trainer Selection.....	5
<b>Section 2 - Safety Considerations and Precautions .....</b>	<b>6</b>
2.1 Stationary Conveyors.....	6
2.2 Operating Conveyors.....	6
<b>Section 3 - Pre-Installation Checks and Options.....</b>	<b>7</b>
3.1 Checklist .....	7
3.2 Optional Installation Accessories.....	8
<b>Section 4 - Installation Instructions.....</b>	<b>9</b>
<b>Section 5 - Pre-Operation Checklist and Testing.....</b>	<b>12</b>
5.1 Pre-Op Checklist .....	12
5.2 Test Run the Conveyor .....	12
<b>Section 6 - Maintenance.....</b>	<b>13</b>
6.1 New Installation Inspection.....	13
6.2 Routine Visual Inspection.....	13
6.3 Routine Physical Inspection .....	13
6.4 Roller Replacement Instructions.....	14
6.5 Sensor Roller Replacement Instructions.....	16
6.6 Maintenance Log.....	17
6.7 Maintenance Checklist .....	18
<b>Section 7 - Troubleshooting .....</b>	<b>19</b>
<b>Section 8 - Specs and CAD Drawings.....</b>	<b>20</b>
8.1 Specs and Guidelines .....	20
8.2 CAD Drawing - PT Smart Standard.....	21
<b>Section 9 - Replacement Parts .....</b>	<b>22</b>
9.1 Replacement Parts List .....	22
<b>Section 10 - Other Flexco Conveyor Products .....</b>	<b>23</b>

# Section 1 - Important Information

---

## 1.1 General Introduction

We at Flexco are very pleased that you have selected a PT Smart™ Belt Trainer for your conveyor system.

This manual will help you to understand the installation, operation and maintenance of this product and assist you in making it work up to its maximum efficiency over its lifetime of service.

It is essential for safe and efficient operation that the information and guidelines presented be properly understood and implemented. This manual will provide safety precautions, installation instructions, maintenance procedures and troubleshooting tips. In addition, please follow all standard, approved safety guidelines when working on your conveyor.

If, however, you have any questions or problems that are not covered, please visit our website or contact our Customer Service Department:

**Customer Service: +27-11-608-4180**

**Visit [www.flexco.com](http://www.flexco.com) for other Flexco locations and products.**

Please read this manual thoroughly and pass it on to any others who will be directly responsible for installation, operation and maintenance of this product. While we have tried to make the installation and service tasks as easy and simple as possible, **this product does however require correct installation and regular inspection and maintenance to maintain top working condition.**

## 1.2 User Benefits

Belt mistracking is a common problem that produces various problems, ranging from belt and structure damage to product spillage and safety issues. By utilising the PT Smart™, it is possible to correct a belt that is mistracking and causing these problems. Multiple units may be required depending on the length of the mistracking belt.

# Section 1 - Important Information

## 1.3 Proper Belt Trainer Selection

MODEL	APPLICATION RANGE
Belt Positioner™	Return side only, 140 N/mm max tension on Small, Medium and Large; 210 N/mm max tension on Extra Large. Also works on reversing belts.
PTEZ™	Medium-duty belts up to 280 N/mm max tension. Also works on reversing belts.
PT Smart™	Medium-duty belts up to 280 N/mm max tension. Belt width + 75mm idler. Belt thickness 25mm maximum.
PT Max™ Adjustable	Heavy-duty belts up to 525 N/mm max Generally 19mm to 25mm thick Belt width 900 - 1500mm
HD PT Max™ Adjustable	Heavy-duty belts up to 1050 N/mm max tension. Belt width 1350 - 2100mm

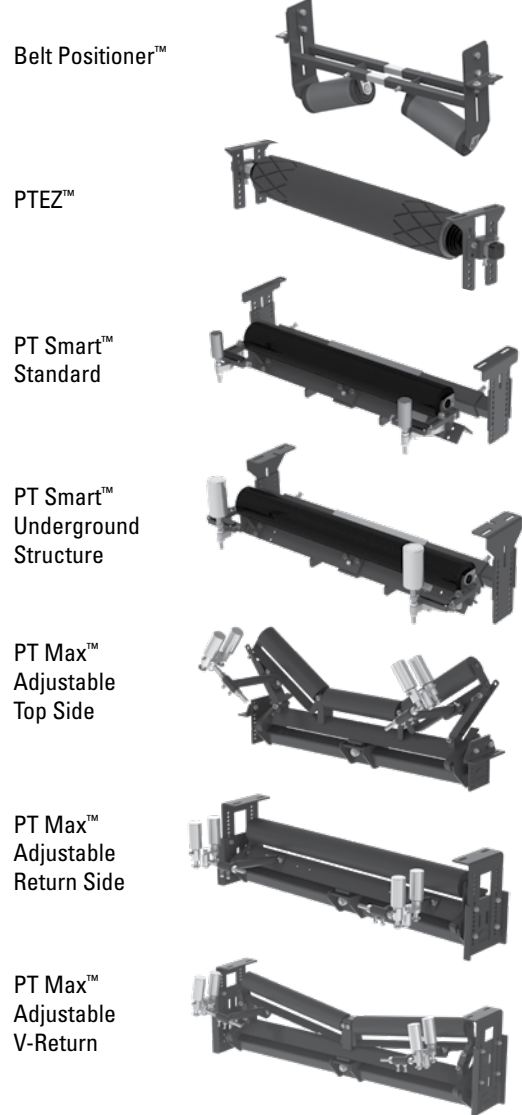

Conveyor Criteria	Belt Positioner™	PTEZ™	PT Smart™	PT Max™	Heavy Duty PT Max™	Super Duty PT Max™
Top side mistracking	No	No	No	Yes	Yes	Yes
Return side mistracking	Yes	Yes	Yes	Yes	Yes	Yes
Reversing	Yes	Yes	No	No	No	No
Belt mistracking to one side	Better	Better	Better	Better	Better	Better
Belt mistracking to both sides	Acceptable	Better	<b>Best</b>	<b>Best</b>	<b>Best</b>	<b>Best</b>
Inconsistent tracking problem	Good	Better	<b>Best</b>	<b>Best</b>	<b>Best</b>	<b>Best</b>
Belt is cupped (heavy)	<b>Best</b> ‡	Better‡	Better	Better	Better	Better
Belt has edge damage	<b>Best</b>	<b>Best</b>	Good	Good	Good	Good
Ease of Installation	<b>Best</b>	Better	Good	Good	Good	Good
Belt has low running tension (150-52.5 N/mm)	Good	Good	Good	Good	N/A	N/A
Belt has medium running tension (300-280 N/mm)	Better	Better	Better	<b>Best</b>	<b>Best</b>	<b>Best</b>
Belt has high running tension (280+ N/mm)	N/A	N/A	N/A	Better	<b>Best</b>	<b>Best</b>
Approx. "upstream" effect*Δ	15 M	6 M	6 M	15 M	15 M	15 M
Approx. "downstream" effect*Δ	15 M	30 - 36 M	36 - 45 M	45 - 61 M	45 - 61 M	45 - 61 M

‡ Installed on the clean side of the return belt

\* Typical results; actual results may vary

Δ Disc idlers have the potential to reduce these numbers

## Section 2 - Safety Considerations and Precautions

---

Before installing and operating the PT Smart™ Belt Trainer, it is important to review and understand the following safety information.

There are setup, maintenance and operational activities involving both **stationary** and **operating** conveyors. Each case has a safety protocol.

---

### 2.1 Stationary Conveyors

The following activities are performed on stationary conveyors:

- Installation
- Tension adjustments
- Roll Replacement
- Cleaning
- Repairs

#### **DANGER**

It is imperative that OSHA/MSHA Lockout/Tagout (LOTO) regulations, 29 CFR 1910.147, be followed before undertaking the preceding activities. Failure to use LOTO exposes workers to uncontrolled behaviour of the trainer caused by movement of the conveyor belt. Severe injury or death can result.

#### **Before working:**

- Lockout/Tagout the conveyor power source
- Disengage any takeups
- Clear the conveyor belt or clamp securely in place

#### **WARNING**

#### **Use Personal Protective Equipment (PPE):**

- Safety eyewear
- Hardhats
- Safety footwear

Close quarters and heavy components create a worksite that compromises a worker's eyes, feet and skull. PPE must be worn to control the foreseeable hazards associated with conveyor belt components. Serious injuries can be avoided.

### 2.2 Operating Conveyors

There are two routine tasks that must be performed while the conveyor is running:

- Inspection of the sealing performance
- Dynamic troubleshooting

#### **DANGER**

Every belt conveyor is an in-running nip hazard. Never touch or prod an operating trainer. Conveyor hazards can cause instantaneous amputation and entrapment.

#### **WARNING**

Never adjust anything on an operating trainer. Unforeseeable belt projections, tares, and materials can cause violent movements of the trainer structure. Flailing hardware can cause serious injury or death.

#### **WARNING**

Belt trainers can become projectile hazards. Stay as far from the trainer as practical and use safety eyewear and headgear. Missiles can inflict serious injury.

## Section 3 - Pre-installation Checks and Options

---

### 3.1 Checklist

- Check the model and size of the belt trainer. Is it the right one for your beltline?
- Check the PT Smart™ to be sure all the parts are included in the shipment.
- Find the Information Packet in the shipment.
- Review the “Tools Needed” section on the front of the installation instructions.
- Prepare the conveyor site:
  - Identify the point(s) of mistracking, expecting 36-45m of downstream influence.
  - Position the unit 6m after the start of the mistracking.
  - Identify an opening of at least 6m if possible to avoid interference with sensor rollers during installation.
  - Remove old tracking devices.
  - If the conveyor has disc idlers, replace one idler before and one idler after the location where the trainer will be installed with a standard idler.

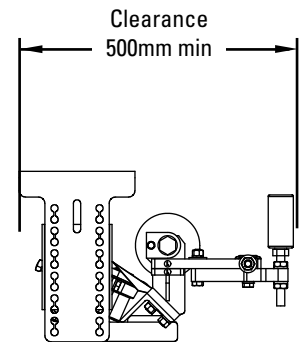

## Section 3 - Pre-Installation Checks and Options (cont.)

---

### 3.2 Optional Installation Accessories

Optional tools can make the installation of the PT Smart™ Belt Trainer easier and faster.

#### Flex-Lifter™ Conveyor Belt Lifter

Description	Ordering Number	Item Code
Medium Flex-Lifter 900 - 1500 mm	FL-M	76469
Large Flex-Lifter 1200 - 1800 mm	FL-L	76470
XL Flex-Lifter 1800-2400 mm	FL-XL	76983

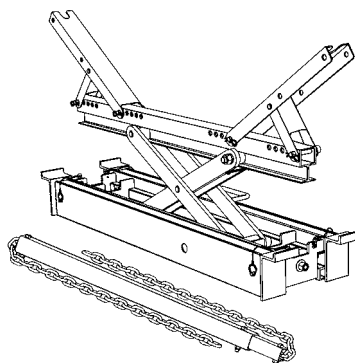

#### Flex-Lifter™ Conveyor Belt Lifter

The Flexco Flex-Lifter makes the job of lifting the conveyor belt easy and safe. Using two Flex-Lifters, the belt can be quickly lifted out of the way to install the PT Smart™. The Flex-Lifter has the highest safe lift rating available at 1810 kg. And it's versatile. It can also be used to lift topside or return side belt for splicing, roller replacement or other maintenance jobs. Available in three sizes: Medium for belt widths 900 - 1500mm, Large for belt widths 1200 - 1800mm, and XL for belt widths 1800 - 2400mm.



# Section 4 - Installation Instructions - PT Smart™

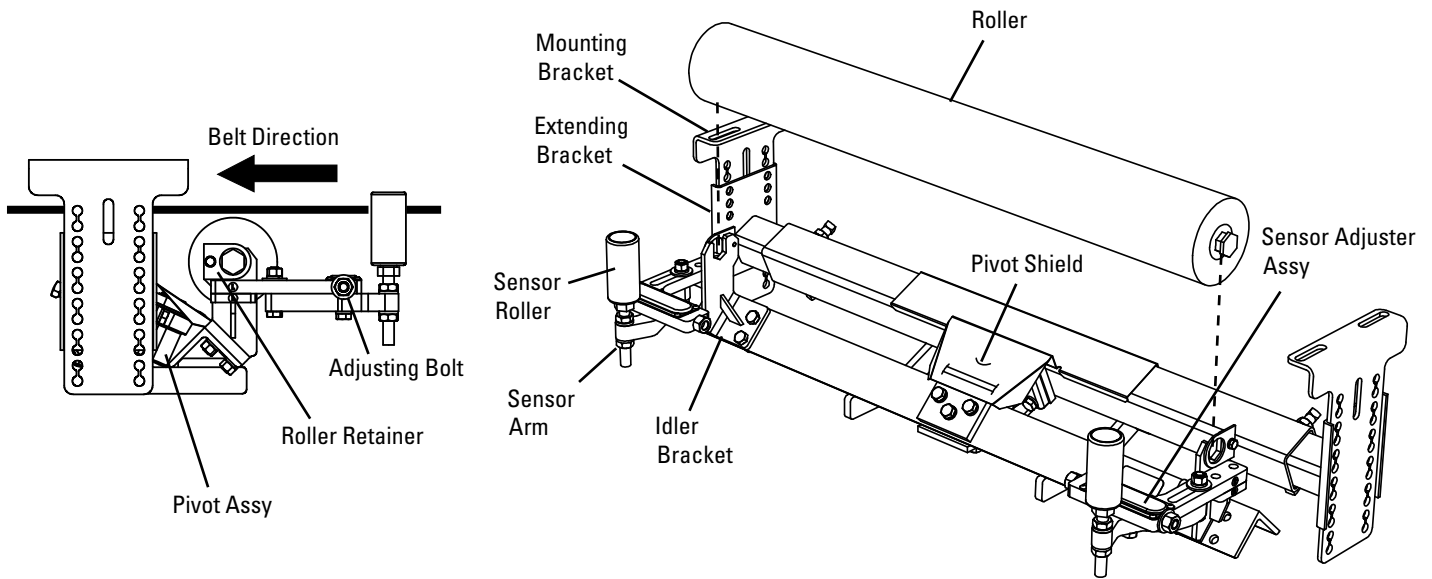

**Physically lock out and tag the conveyor at the power source before you begin cleaner installation.**

**CAUTION: Components may be heavy. Use safety-approved lifting procedures.**

<b>Tools Needed:</b>	
- Tape measure	- Cutting torch
- 19mm Spanner	- Come-alongs (2) (680 Kg min.)
- Medium or large adjustable spanner	- Any necessary equipment for moving and lifting heavy components

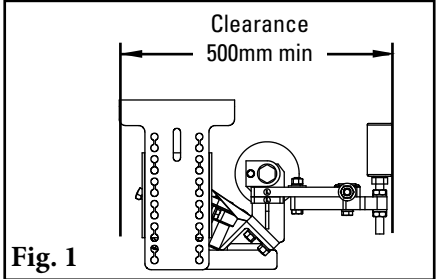

Fig. 1

- 1. Prepare the conveyor site:**
  - Identify the point(s) of mistracking, expecting 36-45 M of downstream influence.
  - Position the unit 6 M after the start of the mistracking.
  - Identify an opening of at least 500mm if possible to avoid interference with sensor rollers during installation (Fig. 1).
  - Remove old tracking devices.

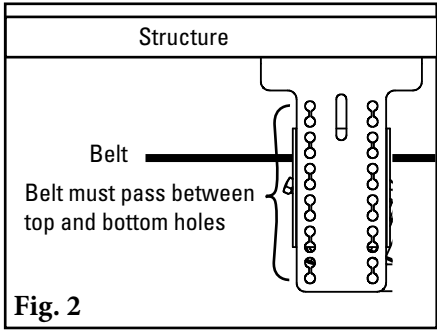

Fig. 2

- 2. Position mounting brackets.** May be mounted to existing idler bracket mounts OR to outside of structure, if structure width is belt width +450mm or less. Be sure belt passes between top and bottom mounting holes (Fig 2).

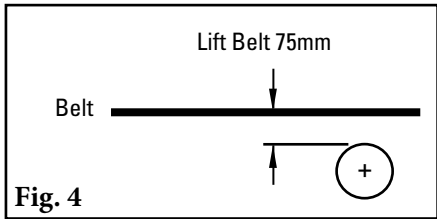
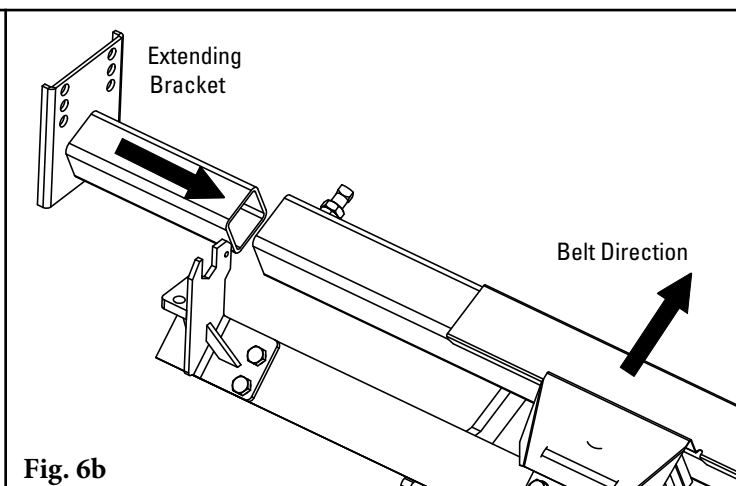
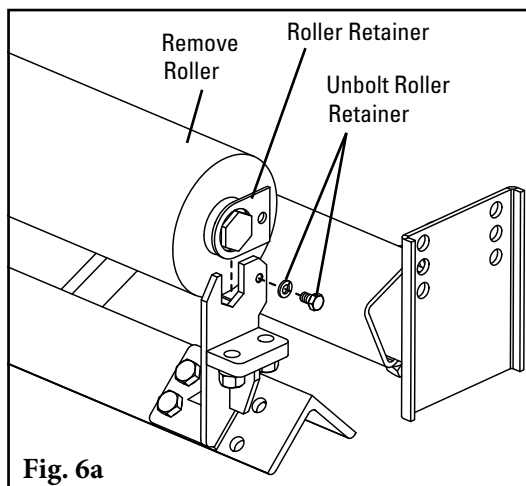

Fig. 4

- 3. Install mounting brackets.** Measure from a fixed location on both sides to ensure alignment.
- 4. Lift the belt** approximately 75mm where the trainer will be installed (Fig. 4).
- 5. Remove existing idler** (if there is one in the location). **NOTE:** If the conveyor has disc idlers, replace one idler before and one idler after the location where the trainer will be installed with a standard idler.

## Section 4 - Installation Instructions - PT Smart™

6. **Remove Roller** by unbolting Roller Retainer (Fig. 6a). Determine orientation of trainer and remove far side Extending Bracket (Fig. 6b).



7. **Attach Extending Bracket** to mounting bracket already installed on far side of conveyor (Fig. 7). Finger-tighten bolts for future adjustment. Top bolt holes should be even with the normal height of the belt.
8. **Slide the far end of main frame** onto the extending bracket assembled in Step 7 (Fig. 8).

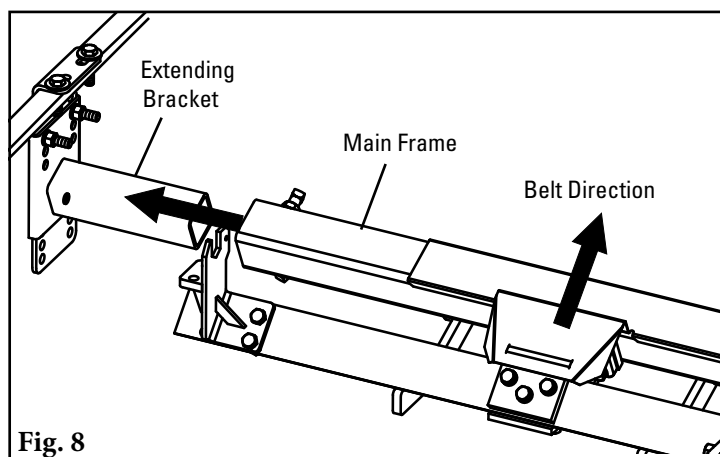
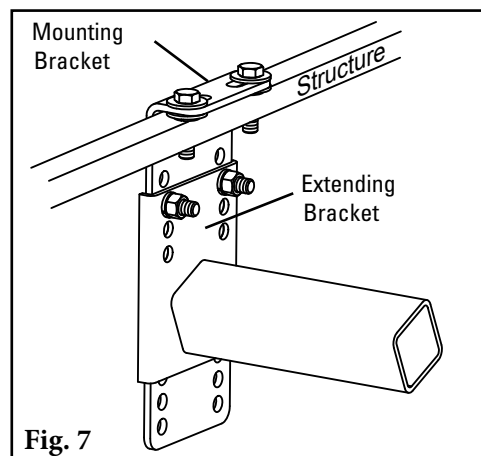

9. **Lift near end of main frame** and attach extending bracket to mounting bracket (Fig. 9a). Ensure main frame is centred on the Extending Brackets (equal length of extenders showing on both sides) (Fig. 9b).

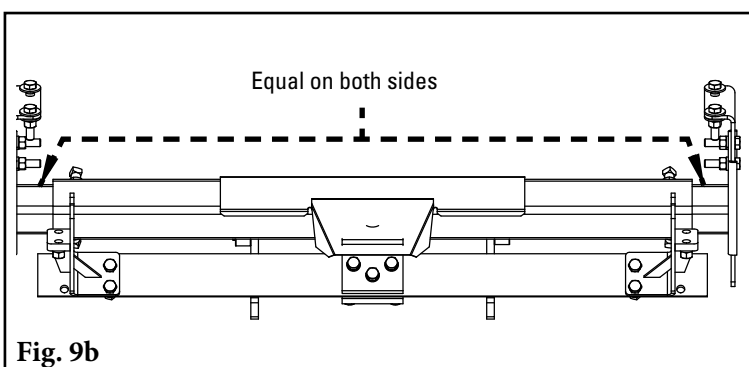
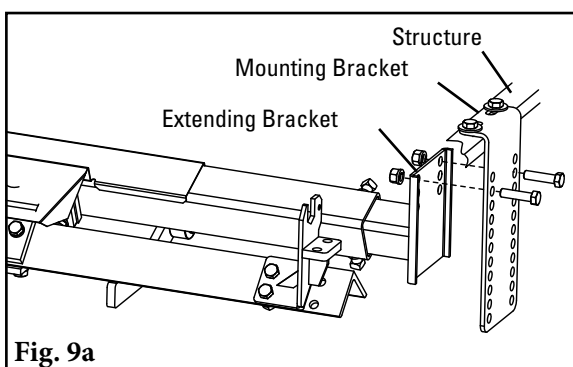

# Section 4 - Installation Instructions - PT Smart™

- 10. Reinstall roller and re-bolt roller retainer (Fig. 10).
- 11. Lower the belt. Ensure belt completely contacts roller. Raise extending brackets one hole if there is not good contact (Fig. 9). Tighten all bolts.

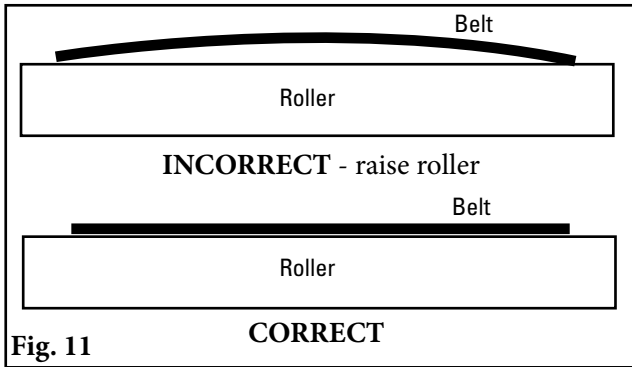

Fig. 11

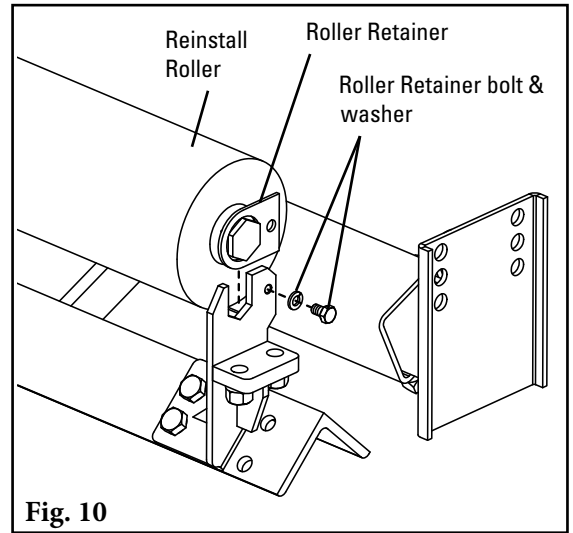

Fig. 10

- 12. Install sensor adjuster assemblies using included bolts. Ensure left and right assemblies are installed on the correct sides. Adjust sensor rolls vertically using the adjustment nuts so the belt is centered on the roller.

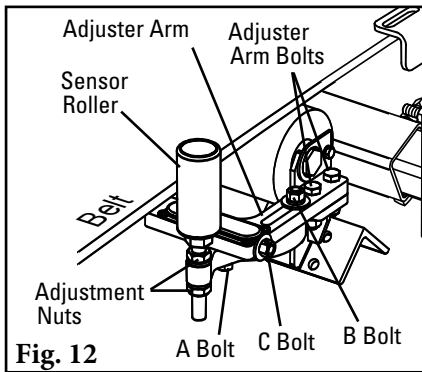

Fig. 12

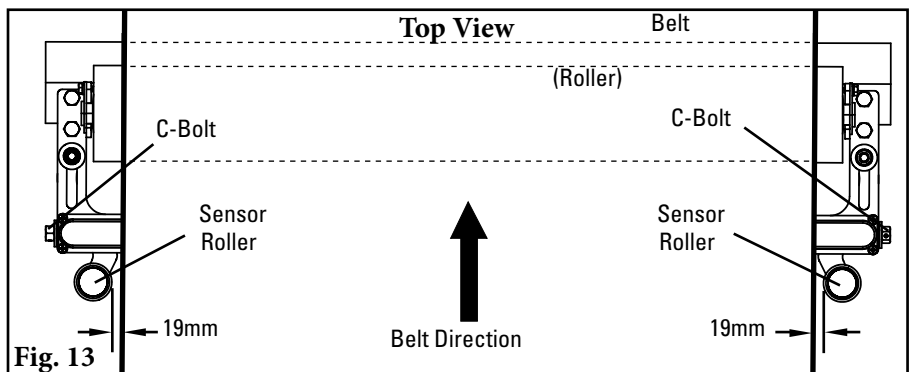

Fig. 13

- 13. Adjust sensor rollers so they are 19mm from the belt on each side. Adjust by loosening "A" and "B" bolts (shown in Fig. 12), then turning the "C" bolts (Fig. 13).
- 14. Pivot the frame 13mm to the side it is mistracking. Bring sensor roller in until it touches the belt. Move opposite sensor roller out to 38mm from the belt (Fig 14).
- 15. Tighten all bolts and proceed to next page for pre-op checklist.

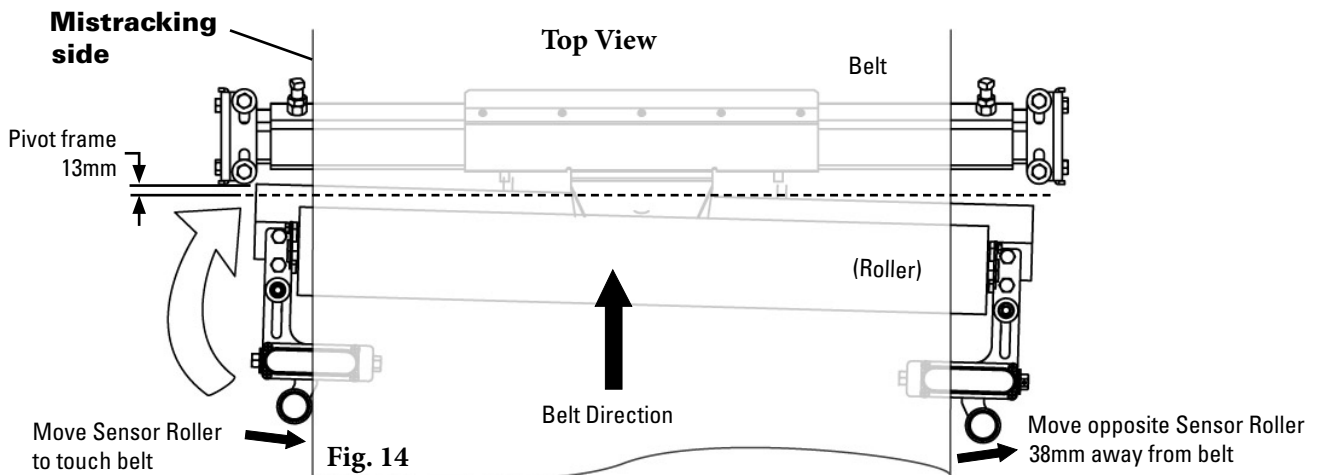

Fig. 14

# Section 5 - Pre-Operation Checklist and Testing

## 5.1 Pre-Op Checklist

- Recheck that all fasteners are tight
- Apply all supplied labels
- Be sure that all installation materials and tools have been removed from the belt and conveyor area

## 5.2 Test Run the Conveyor

- Run the conveyor for at least 15 minutes and confirm the belt is tracking properly.
- If belt is still mistracking too far to one side, bring that sensor roller in toward the centre. Make adjustments of 6mm at a time (Fig. 1). Do not pinch the belt between the rollers; rollers overall should be 38mm wider than the belt (Fig. 2).

**NOTE:** If the conveyor has disc idlers, the belt may not get the full downstream tracking effect.

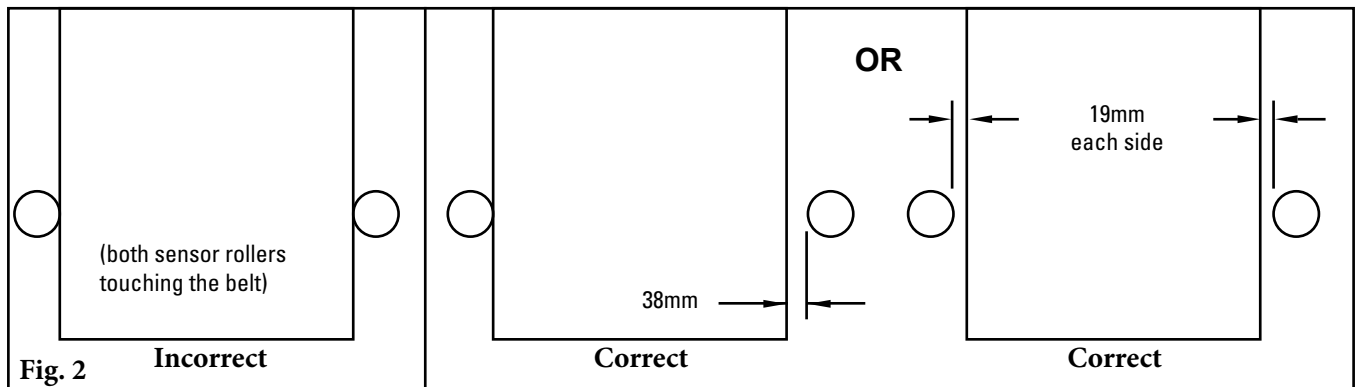
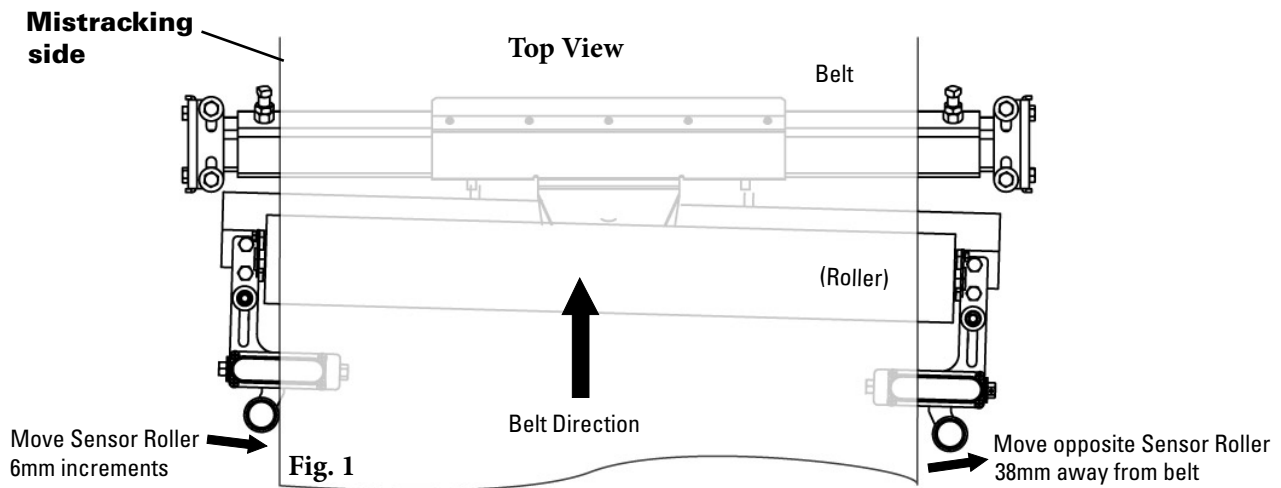

## Section 6 - Maintenance

---

Flexco belt trainers are designed to operate with minimum maintenance. However, to maintain superior performance some service is required. When the trainer is installed a regular maintenance program should be set up. This program will ensure that the trainer operates at optimal efficiency, and problems can be identified and fixed before any damage is done to the belt, the trainer, other conveyor components, or structure.

All safety procedures for inspection of equipment (stationary or operating) must be observed. The PT Smart is in direct contact with the moving belt. Only visual observations can be made while the belt is running. Service tasks can be done only with the conveyor stopped and by observing the correct lockout/tagout procedures.

### 6.1 New Installation Inspection

After the PT Smart™ has run for 15 minutes a visual inspection should be made to ensure the trainer is performing properly. Make adjustments as needed.

### 6.2 Routine Visual Inspection (every 2-4 weeks)

A visual inspection of the PT Smart can determine:

- If the belt is tracking as required
- If the trainer is moving freely
- If the main frame is free of material and rolling properly
- If there is damage to the main frame or other components
- If the sensor rollers are turning freely and without damage

If any of the above conditions exist, a determination should be made on when the conveyor can be stopped for trainer maintenance.

### 6.3 Routine Physical Inspection (every 6-8 weeks)

When the conveyor is not in operation and properly locked and tagged out, a physical inspection of the trainer to perform the following tasks:

- Clean material buildup off the trainer and components.
- Closely inspect both sensor rollers for free movement and wear. Replace if needed.
- Closely inspect main roller for free movement and wear. Replace if needed.
- Pivot unit to ensure full and easy movement.
- Closely inspect complete unit for damage.
- Inspect all fasteners for tightness and wear. Tighten or replace if needed.
- When maintenance tasks are completed, test run the conveyor to ensure the trainer is performing properly.

# Section 6 - Maintenance

## 6.4 Roller Replacement Instructions

**Physically lock out and tag the conveyor at the power source before you begin cleaner installation.**

**CAUTION: Components may be heavy. Use safety-approved lifting procedures.**

- 1. Remove tension from belt.** Use a Flex-Lifter or other appropriate lifting equipment to lift the belt approx. 75mm off the trainer.
- 2. Remove roller** by unbolting Roller Retainers (Fig. 2).

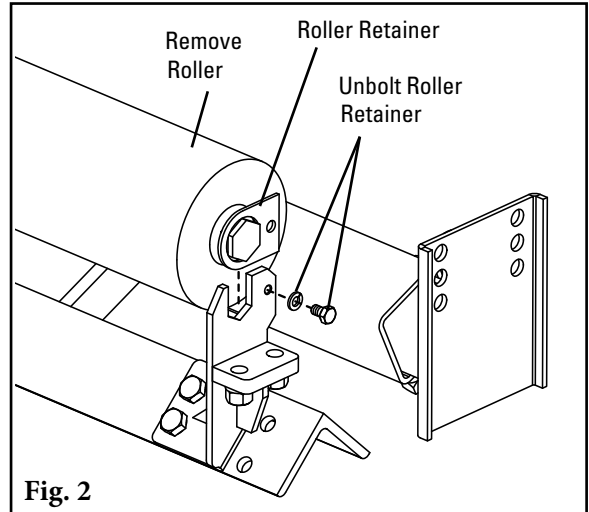

Fig. 2

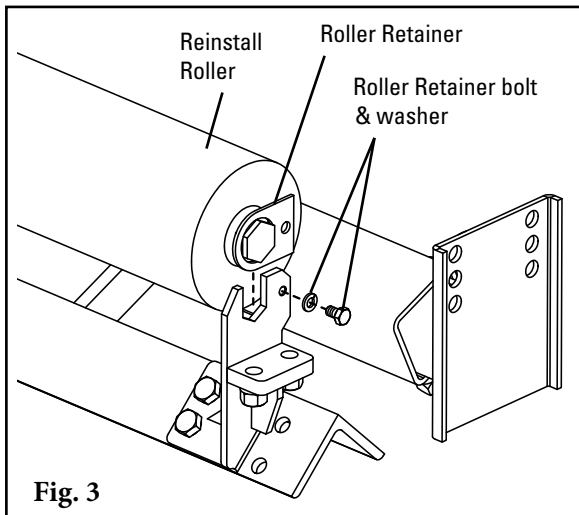

Fig. 3

- 3. Install new roller** and re-bolt roller retainer (Fig. 3). Confirm roller turns smoothly.

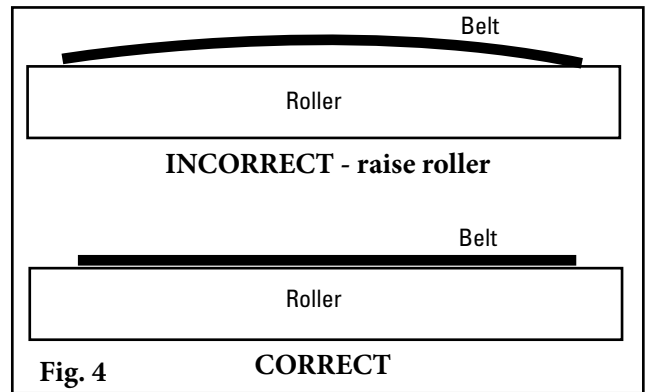

Fig. 4

- 4. Lower the belt.** Ensure belt completely contacts roller. Raise brackets if there is not good contact (Fig. 4). Tighten all bolts.

- 5. Adjust sensor rollers** so they are 19mm from the belt on each side. Adjust by loosening the "A" and "B" bolts, then turning the "C" bolts (Fig. 5a & b).

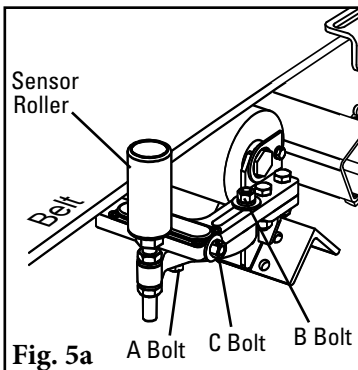

Fig. 5a

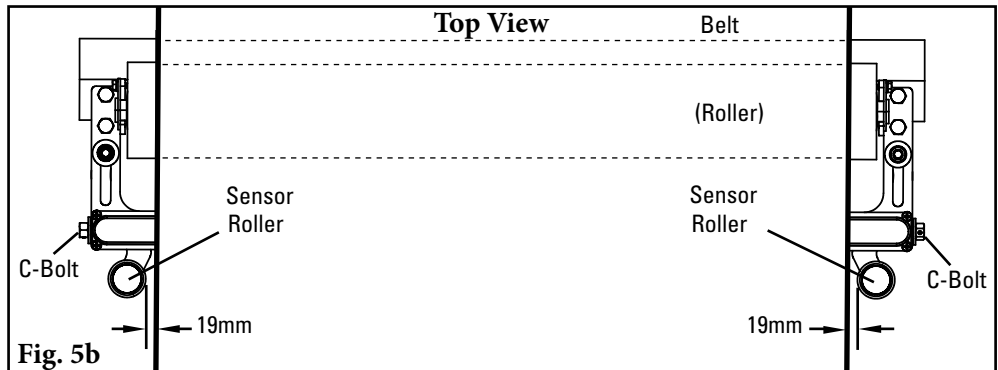
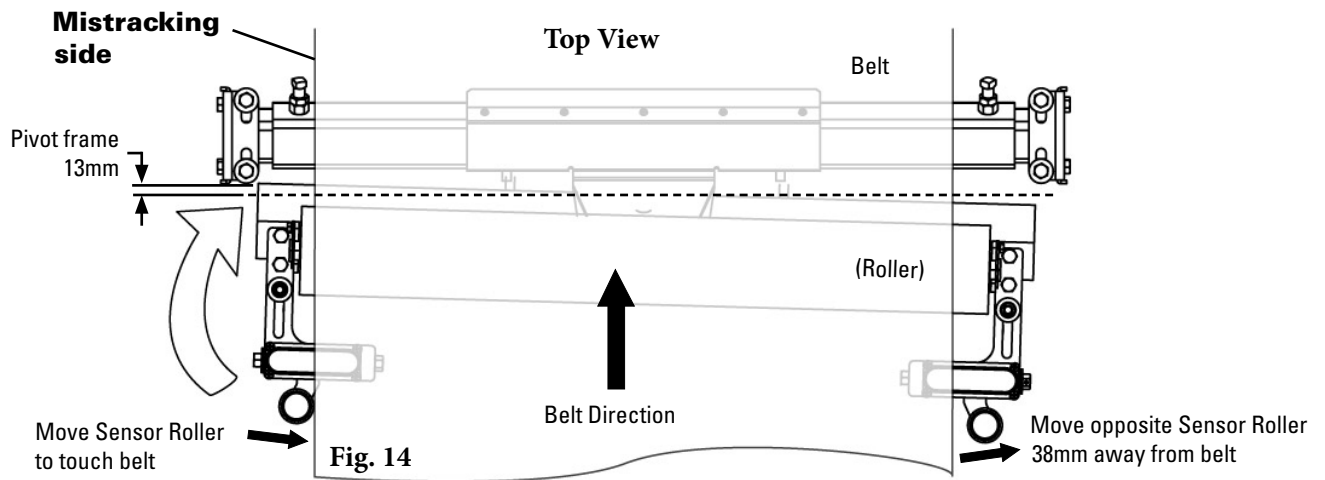

Fig. 5b

## Section 6 - Maintenance

---

- Pivot the frame to the side it is mistracking.** Bring sensor roller in until it touches the belt. Move opposite sensor roller out to 38mm from the belt (Fig 6).



- Tighten all bolts and refer to pre-op checklist (page 10) before running the conveyor.** If belt is still mistracking, refer to Section 5.2 on page 10.

## Section 6 - Maintenance (cont.)

### 6.5 Sensor Roller Replacement Instructions

1. Loosen "A" and "B" bolts, turn "C" bolts to move sensor rollers away from the belt (Fig. 1).
2. Loosen nut at base of sensor roller and remove from adjuster arm (Fig. 2).

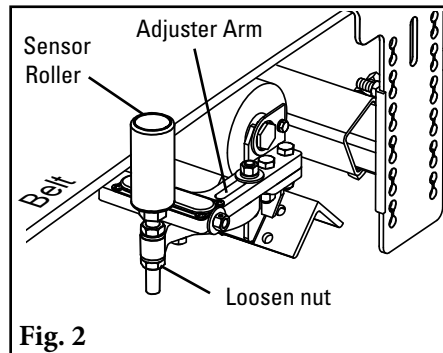
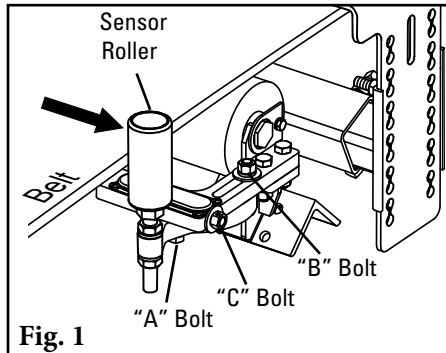

3. Install new sensor roller, reinstall nut, and adjust the sensor roll vertically using the adjustment nuts so the belt aligns with the center of the roller.
4. Adjust sensor rollers so they are 19mm from the belt on each side. Adjust by turning the "C" bolts (Fig. 4).

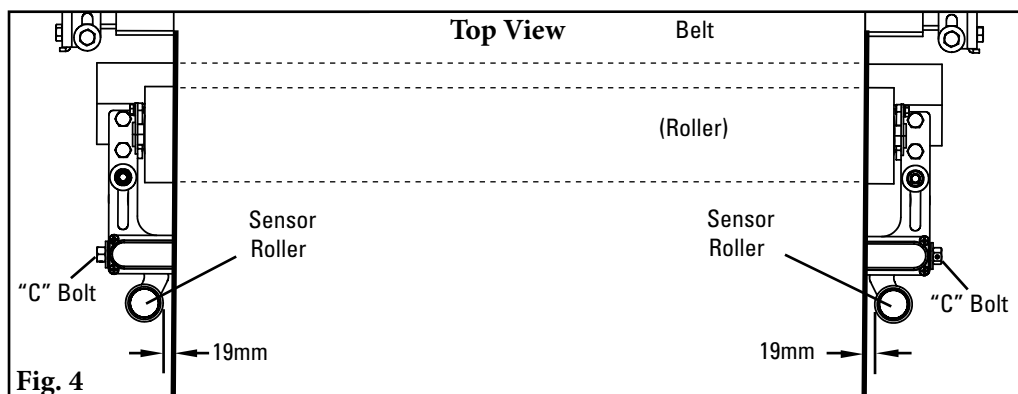

5. Pivot the frame 12mm to the side it is mistracking. Bring sensor roller in until it touches the belt. Move opposite sensor roller out to 38mm from the belt (Fig 5).

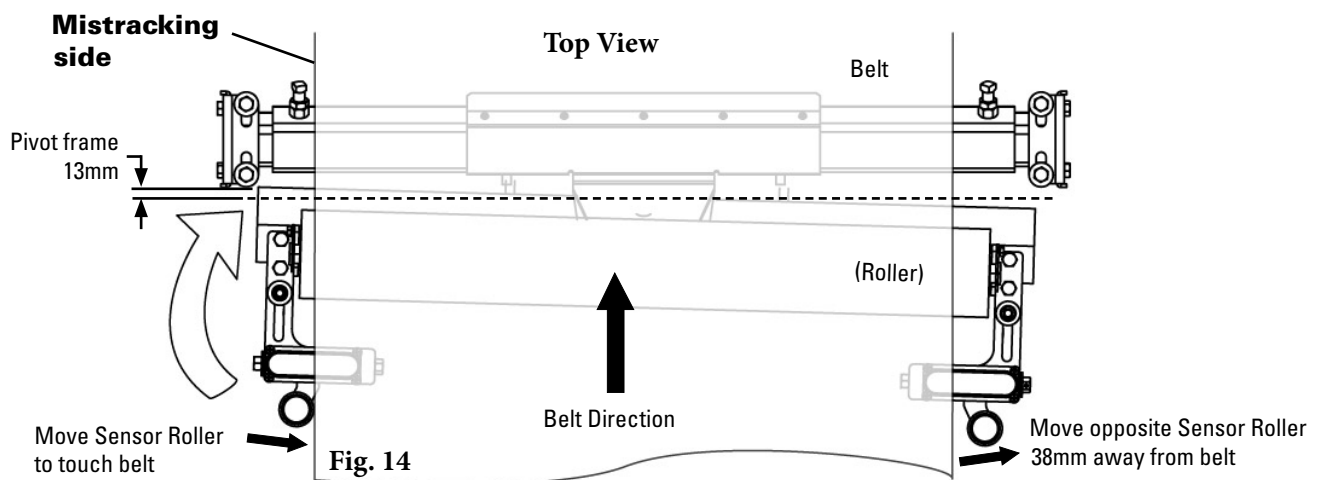

6. Tighten all bolts and refer to pre-op checklist (page 10) before running the conveyor. If belt is still mistracking, refer to Section 5.2 on page 10.



## Section 6 - Maintenance (cont.)

---

### 6.6 Maintenance Log

Conveyor Name/No. \_\_\_\_\_

Date: \_\_\_\_\_ Work done by: \_\_\_\_\_ Service Quote #: \_\_\_\_\_

Activity: \_\_\_\_\_

---

Date: \_\_\_\_\_ Work done by: \_\_\_\_\_ Service Quote #: \_\_\_\_\_

Activity: \_\_\_\_\_

---

Date: \_\_\_\_\_ Work done by: \_\_\_\_\_ Service Quote #: \_\_\_\_\_

Activity: \_\_\_\_\_

---

Date: \_\_\_\_\_ Work done by: \_\_\_\_\_ Service Quote #: \_\_\_\_\_

Activity: \_\_\_\_\_

---

Date: \_\_\_\_\_ Work done by: \_\_\_\_\_ Service Quote #: \_\_\_\_\_

Activity: \_\_\_\_\_

---

Date: \_\_\_\_\_ Work done by: \_\_\_\_\_ Service Quote #: \_\_\_\_\_

Activity: \_\_\_\_\_

---

Date: \_\_\_\_\_ Work done by: \_\_\_\_\_ Service Quote #: \_\_\_\_\_

Activity: \_\_\_\_\_

---

Date: \_\_\_\_\_ Work done by: \_\_\_\_\_ Service Quote #: \_\_\_\_\_

Activity: \_\_\_\_\_

---

# Section 6 - Maintenance

## 6.7 Belt Trainer Maintenance Checklist

Site: \_\_\_\_\_ Inspected by: \_\_\_\_\_ Date: \_\_\_\_\_

PT Smart: \_\_\_\_\_ Serial Number: \_\_\_\_\_

### Beltline Information:

Beltline Number: \_\_\_\_\_ Belt Condition: \_\_\_\_\_

Belt Width:  450mm  600mm  750mm  900mm  1050mm  1200mm  1350mm  1500mm  1800mm

Belt Speed: \_\_\_\_\_ Belt Thickness: \_\_\_\_\_

### Idler Roller Life:

Date Roller Installed: \_\_\_\_\_ Date Roller Inspected: \_\_\_\_\_ Estimated Roller Life: \_\_\_\_\_

Roller Condition: \_\_\_\_\_

### Sensor Roller Life (Right Side):

Date Roller Installed: \_\_\_\_\_ Date Roller Inspected: \_\_\_\_\_ Estimated Roller Life: \_\_\_\_\_

Roller Condition: \_\_\_\_\_

### Sensor Roller Life (Left Side):

Date Roller Installed: \_\_\_\_\_ Date Roller Inspected: \_\_\_\_\_ Estimated Roller Life: \_\_\_\_\_

Roller Condition: \_\_\_\_\_

PT Smart Frame Condition:  Good  Bent  Rusted

Overall PT Smart Performance: ( Rate the following 1 - 5, 1=very poor - 5= very good )

Appearance:  Comments: \_\_\_\_\_

Location:  Comments: \_\_\_\_\_

Maintenance:  Comments: \_\_\_\_\_

Performance:  Comments: \_\_\_\_\_

Other Comments: \_\_\_\_\_

\_\_\_\_\_

\_\_\_\_\_

\_\_\_\_\_

\_\_\_\_\_

\_\_\_\_\_

\_\_\_\_\_

## Section 7 - Troubleshooting

---

Problem	Possible Cause	Possible Solutions
Little to no effect on trouble area of belt	Unit installed in wrong location	Relocate unit 6M after start of problem area of belt
	Incorrect tension on unit	Increase height of unit to provide 13-25mm lift on belt
	Unit mis-adjusted	Adjust sensor roller to provide more activation of unit
	Buildup on main roller	Clean unit
Belt not correcting enough	Unit mis-adjusted	Adjust sensor roll to provide more activation of unit
	Disc idlers on conveyor	Replace one disc idler before and one after the trainer with a standard idler
Belt moving over too much	Unit mis-adjusted	Adjust sensor roll to provide less activation of unit
Belt is jumping sensor roll	Unit located too low in structure	Increase height of unit to provide 13-25mm lift on belt
Belt contacting both side sensors	Unit mis-adjusted	Adjust sensors to provide the 25mm clearance so both sensors do not touch belt
Unit does not pivot	Buildup of material	Clean unit
Main roller not turning	Buildup on main roller	Clean unit
	Main roller bearing bad	Replace main roller

# Section 8 - Specs and CAD Drawings

## 8.1 Specs and Guidelines

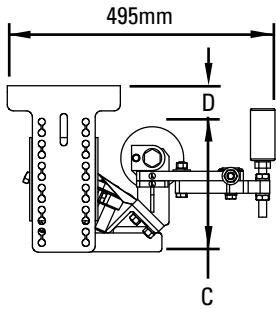
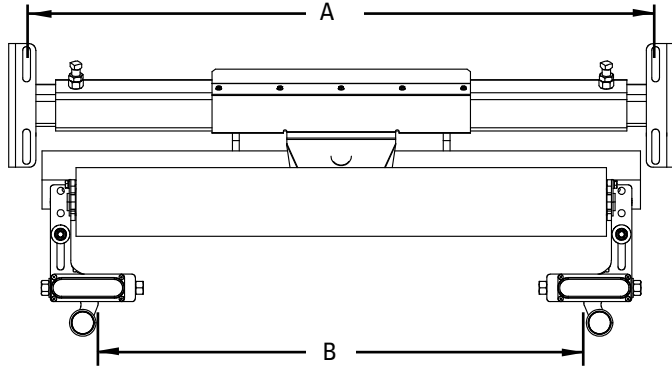

**PT Smart Standard**

Belt Width mm	Item Code	A	B	C	D (vertical adjustment)
450	77664	575-875mm	250-575 mm	250 mm	0-250 mm
600	77665	725-1025mm	400-725 mm		
750	77666	875-1175mm	550-875 mm		
900	77667	1025-1325mm	700-1025 mm		
1050	77668	1175-1475mm	825-1175 mm		
1200	77669	1325-1625mm	1000-1325 mm		
1350	77670	1475-1775mm	1150-1475 mm		
1500	77671	1625-1925mm	1300-1625 mm		
1800	77672	1925-2225mm	1600-1925 mm		

# Section 8 - Specs and CAD Drawings

## 8.2 CAD Drawing - PT Smart Standard

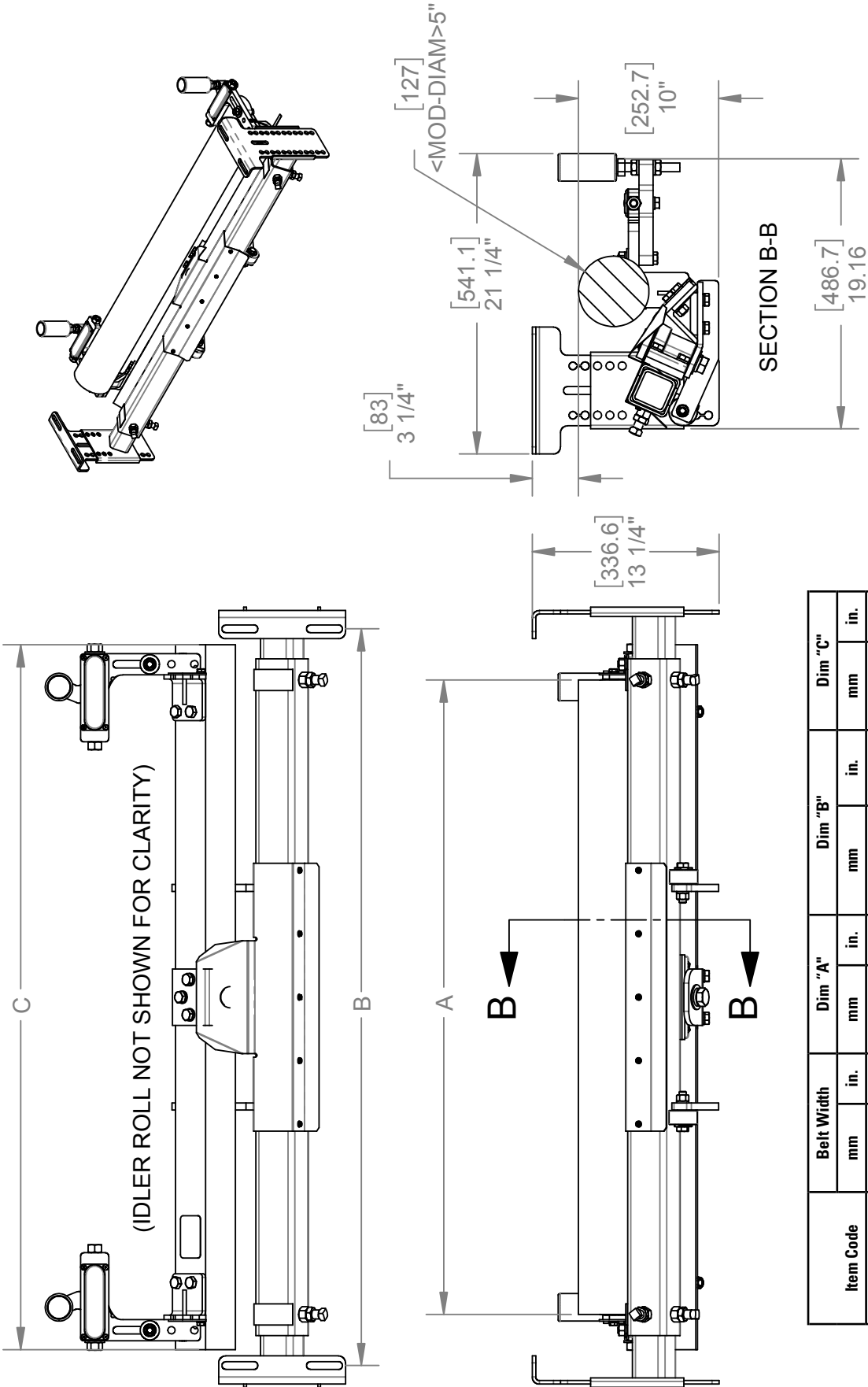

Item Code	Belt Width		Dim "A"		Dim "B"		Dim "C"	
	mm	in.	mm	in.	mm	in.	mm	in.
77664	450 mm	18"	525	21"	575-875 mm	23-35"	650 mm	26"
77665	600 mm	24"	675	27"	725-1025 mm	29-41"	800 mm	32"
77666	750 mm	30"	825	33"	875-1175 mm	35-47"	950 mm	38"
77667	900 mm	36"	975	39"	1025-1325 mm	41-53"	1100 mm	44"
77668	1050 mm	42"	1125	45"	1175-1475 mm	47-59"	1250 mm	50"
77669	1200 mm	48"	1275	51"	1325-1625 mm	53-65"	1400 mm	56"
77670	1350 mm	54"	1425	57"	1475-1775 mm	59-71"	1550 mm	62"
77671	1500 mm	60"	1575	63"	1325-1925 mm	65-77"	1700 mm	68"

# Section 9 - Replacement Parts

## 9.1 Replacement Parts List

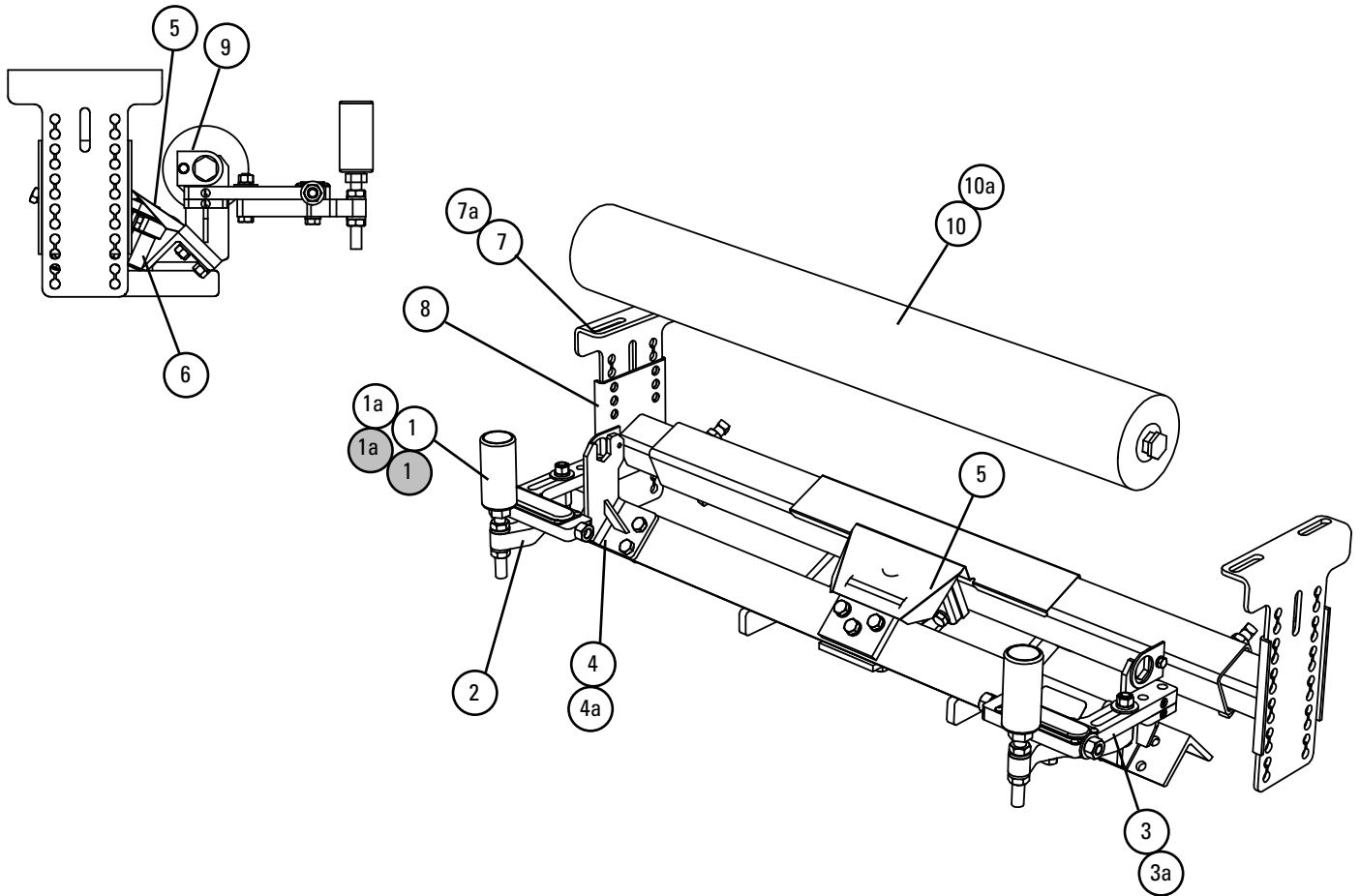

### Replacement Parts

Ref	Description	Ordering Number	Item Code
1	PTS STD Sensor Roller (2")	PTS-ASR	93089
1a	PTS HD Sensor Roller (3")	PTS-AHDSR	93090
2	PTS Sensor Arm Kit (incl. 1 ea.)	PTS-SAK	77694
3	PTS RH Sensor Adjuster Assy	PTS-RHSAA	77755
3a	PTS LH Sensor Adjuster Assy	PTS-LHSAA	77756
4	PTS Idler Bracket Kit (incl. L & R)	PTS-IBK	77696
4a	PTS HD Idler Bracket Kit (incl. L & R)	PTS-HIBK	77697
5	PTS Pivot Shield	PTS-PS	77698
6	PTS Pivot Assy (Axle and housing)	PTS-PA	77699
7	PTS Mounting Bracket Kit	PTS-MBK	77700
7a	PTS Mounting Bracket Kit U/G	PTS-MBKUG	77701
8	PTS Extending Bracket Kit (incl. L & R)	PTS-EBK	77702
9	Roller Retainer Kit	RBPRET	73163

\*Hardware included  
Lead time: 1 working day

### Legacy Replacement Sensor Rollers - For PT Smart Units Shipped Prior to Feb. 24, 2021

Ref	Description	Ordering Number	Item Code
L1	PTS STD Sensor Roller (2")	PTS-SR	77691
L1a	PTS HD Sensor Roller (3")	PTS-HDSR	77692

### Replacement Rollers

Ref	Belt Width mm	Description	Ordering Number	Item Code
10	450	PTS Repl Roller 525mm	PTS-RR21	77680
	600	PTS Repl Roller 675mm	PTS-RR27	77681
	750	PTS Repl Roller 825mm	PTS-RR33	77682
	900	PTS Repl Roller 975mm	PTS-RR39	77683
	1050	PTS Repl Roller 1125mm	PTS-RR45	77684
	1200	PTS Repl Roller 1275mm	PTS-RR51	77685
	1350	PTS Repl Roller 1425mm	PTS-RR57	77686
	1500	PTS Repl Roller 1575mm	PTS-RR63	77687
	1800	PTS Repl Roller 1875mm	PTS-RR75	77689

Lead time: 1 working day

## Section 10 - Other Flexco Conveyor Products

---

Flexco provides many conveyor products that help your conveyors to run more efficiently and safely. These components solve typical conveyor problems and improve productivity. Here is a quick overview on just a few of them:

### EZP1 Precleaner



- Patented ConShear™ blade renews its cleaning edge as it wears
- Visual Tension Check™ for optimal blade tensioning and simple retensioning
- Quick and easy one-pin blade replacement
- Material Path Option™ for optimal cleaning and reduced maintenance

### Flex-Lok™ Skirt Clamps

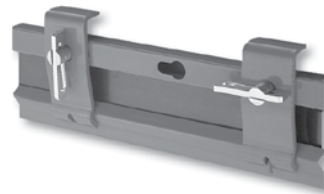

- Eliminates transfer zone spillage
- Interlocking design for easy installation and one-person maintenance
- Unique wedge pin holds rubber securely in place and is easy to adjust
- Available in various models and in stainless steel

### MMP Precleaner



- Extra cleaning power for tough applications
- 250mm TuffShear™ blade provides increased blade-to-belt tension
- A 3-piece telescoping pole is lighter to lift and easier to install
- Dual Quick-Mount Tensioners ensure optimal tension throughout the life of the blade

### PT Max™ Belt Trainer



- Patented “pivot & tilt” design for superior training action
- Dual sensor rollers on each side to minimise belt damage
- Pivot point guaranteed not to freeze up
- Available for topside and return side belts

### MHS Secondary Cleaner with Service Advantage Cartridge



- An easy slide-out cartridge for service
- Cartridge design to speed up blade-change maintenance
- Patented PowerFlex™ Cushions for superior cleaning performance
- Compatible with Flexco mechanical splices

### Belt Ploughs

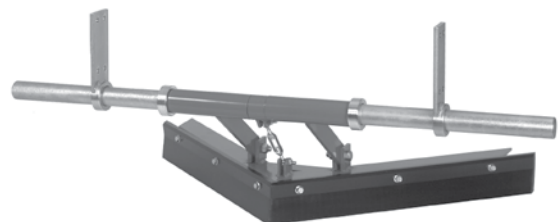

- A belt cleaner for the tail pulley
- Exclusive blade design quickly spirals debris off the belt
- Economical and easy to service
- Available in vee or diagonal models

236 Albert Amon Rd • Meadowdale Ext. 7 • Germiston 1614 • South Africa  
Tel: +27-11-608-4180 • Fax: +27-11-454-5821 • E-mail: flexco@flexco.co.za

Visit [www.flexco.com](http://www.flexco.com) for other Flexco locations and products.

©2021 Flexible Steel Lacing Company. 03/25/21. For reorder: X4784

