

U-Type[®] Secondary Belt Cleaner

Installation, Operation and Maintenance Manual

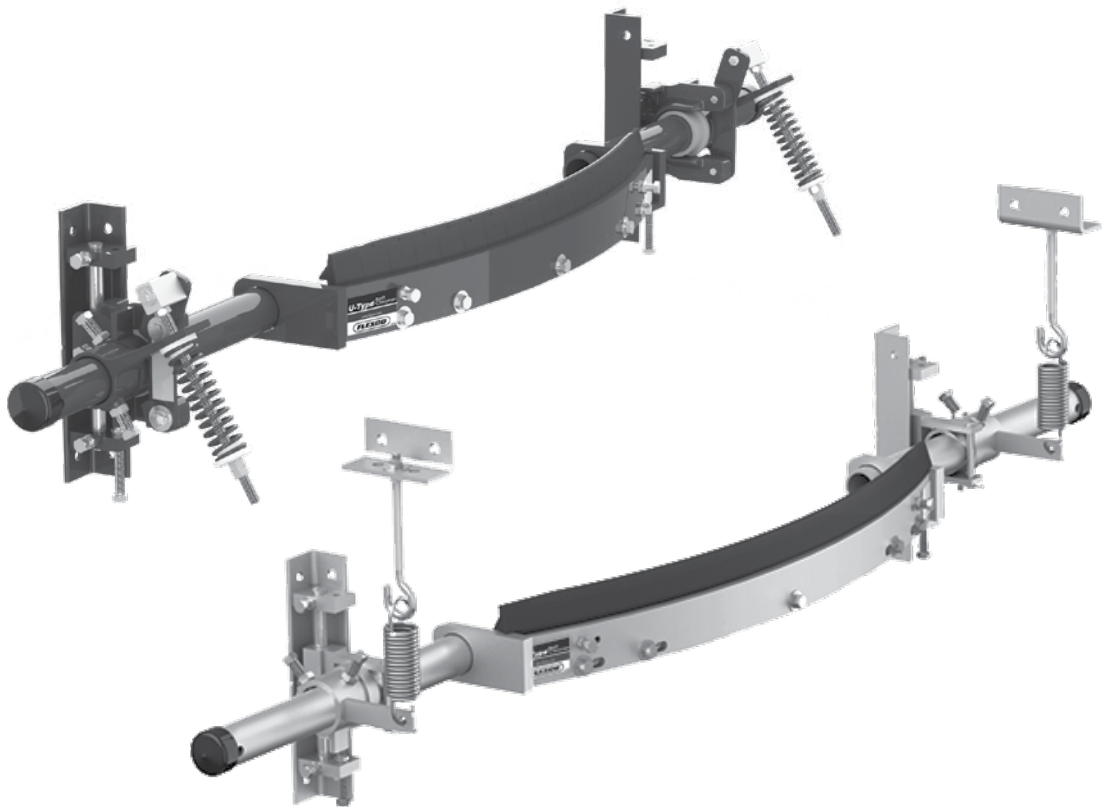

U-Type® Secondary Cleaner

Serial Number: _____

Purchase Date: _____

Purchased From: _____

Installation Date: _____

Serial number information can be found on the Serial Number Label included in the Information Packet shipped in the cleaner carton.

This information will be helpful for any future inquiries or questions about belt cleaner replacement parts, specifications or troubleshooting.

Table of Contents

Section 1 - Important Information	4
1.1 General Introduction.....	4
1.2 User Benefits	4
1.3 Service Option	4
Section 2 - Safety Considerations and Precautions	5
2.1 Stationary Conveyors.....	5
2.2 Operating Conveyors.....	5
Section 3 - Pre-Installation Checks and Options.....	6
3.1 Checklist.....	6
3.2 Optional Installation Accessories.....	6
3.3 Correct Blade Installation and Tensioning	8
Section 4 - Installation Instructions.....	9
Section 5 - Pre-Operation Checklist and Testing.....	14
5.1 Pre-Op Checklist.....	14
5.2 Test Run the Conveyor	14
Section 6 - Maintenance.....	15
6.1 New Installation Inspection.....	15
6.2 Routine Visual Inspection.....	15
6.3 Routine Physical Inspection	15
6.4 Blade Replacement Instructions.....	16
6.5 Maintenance Log.....	18
6.6 Cleaner Maintenance Checklist.....	19
Section 7 - Troubleshooting	20
Section 8 - Specifications and CAD Drawing	21
8.1 Specs and Guidelines	21
8.2 CAD Drawing - Cleaners with UST Tensioners	22
8.3 CAD Drawing - Cleaners with J-Bolt Tensioners	23
Section 9 - Replacement Parts	24
9.1 Replacement Parts and Poles (Mild Steel)	25
9.2 Replacement Parts and Poles (Stainless Steel).....	26
9.3 Replacement Blades	27
Section 10 - Other Flexco Conveyor Products	31

Section 1 - Important Information

1.1 General Introduction

We at Flexco are very pleased that you have selected a U-Type® Secondary Cleaner for your conveyor system.

This manual will help you to understand the operation of this product and assist you in making it work up to its maximum efficiency over its lifetime of service.

It is essential for safe and efficient operation that the information and guidelines presented be properly understood and implemented. This manual will provide safety precautions, installation instructions, maintenance procedures and troubleshooting tips.

If, however, you have any questions or problems that are not covered, please contact your field representative or our Customer Service Department:

Customer Service: 612-8818-2000

Visit www.flexco.com for other Flexco locations and products.

Please read this manual thoroughly and pass it on to any others who will be directly responsible for installation, operation and maintenance of this cleaner. While we have tried to make the installation and service tasks as easy and simple as possible, **it does however require correct installation and regular inspections and adjustments to maintain top working condition.**

1.2 User Benefits

Correct installation and regular maintenance will provide the following benefits for your operation:

- Reduced conveyor downtime
- Reduced man-hour labour
- Lower maintenance budget costs
- Increased service life for the belt cleaner and other conveyor components

1.3 Service Option

The U-Type® Secondary Cleaner is designed to be easily installed and serviced by your on-site personnel. However, if you would prefer complete turn-key factory service, please contact your local Flexco Field Representative.

Section 2 - Safety Considerations and Precautions

Before installing and operating the U-Type® Secondary Cleaner, it is important to review and understand the following safety information.

There are set-up, maintenance and operational activities involving both **stationary** and **operating** conveyors. Each case has a safety protocol.

2.1 Stationary Conveyors

The following activities are performed on stationary conveyors:

- Installation
- Blade replacement
- Repairs
- Tension adjustments
- Cleaning

DANGER

It is imperative that OSHA/MSHA Lockout/Tagout (LOTO) regulations be followed before undertaking the preceding activities. Failure to use LOTO exposes workers to uncontrolled behavior of the belt cleaner caused by movement of the conveyor belt. Severe injury or death can result.

Before working:

- Lockout/Tagout the conveyor power source
- Disengage any takeups
- Clear the conveyor belt or clamp securely in place

WARNING

Use Personal Protective Equipment (PPE):

- Safety eyewear
- Hardhats
- Safety footwear

Close quarters, springs and heavy components create a worksite that compromises a worker's eyes, feet and skull. PPE must be worn to control the foreseeable hazards associated with conveyor belt cleaners. Serious injuries can be avoided.

2.2 Operating Conveyors

There are two routine tasks that must be performed while the conveyor is running:

- Inspection of the cleaning performance
- Dynamic troubleshooting

DANGER

Every belt cleaner is an in-running nip hazard. Never touch or prod an operating cleaner. Cleaner hazards cause instantaneous amputation and entrapment.

WARNING

Belt cleaners can become projectile hazards. Stay as far from the cleaner as practical and use safety eyewear and headgear. Missiles can inflict serious injury.

WARNING

Never adjust anything on an operating cleaner. Unforseeable belt projections and tears can catch on cleaners and cause violent movements of the cleaner structure. Flailing hardware can cause serious injury or death.

Section 3 - Pre-Installation Checks and Options

3.1 Checklist

- Check that the cleaner size is correct for the beltline width
- Check the belt cleaner carton and make sure all the parts are included
- Review the “Tools Needed” list on the top of the installation instructions
- Check the conveyor site:
 - Will the cleaner be installed on a chute
 - Is the install on an open head pulley requiring mounting structure (see 3.2 - Optional Installation Accessories)

3.2 Optional Installation Accessories

Versatile, adjustable brackets that can be mounted on the conveyor structure so the U-Type® cleaner can be quickly and easily bolted into place. Pole extenders are also available for wide, non-standard conveyor structures.

75666
Mounting Bracket Kit
 (includes 1 left and 1 right bracket)

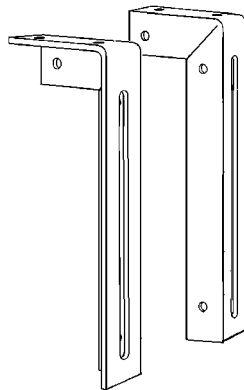

76024
Pole Extender Kit
 (includes 2 pole extenders)

- Use RAPEK for sizes up to 1350mm (54"); use MAPEK for sizes 1500mm (60") and up
- Provides 750mm (30") of extended pole length

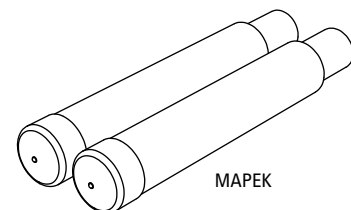
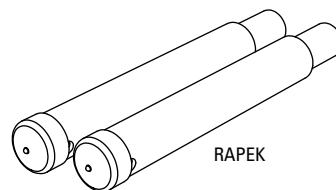

Optional Installation Accessories

Description	Ordering Number	Item Code	Wt. Kg.
Mounting Bracket Kit	EZS2MBK	75666	5.0
60mm (2-3/8") Pole Extender Kit	RAPEK	77423	8.0
72mm (2-7/8") Pole Extender Kit	MAPEK	76024	9.0

Section 3 - Pre-Installation Checks and Options

3.3 Correct Blade Installation and Tensioning

For optimal cleaning efficiency and long wear life, the U-Type® blade must be located and tensioned correctly on the belt. If the cleaner pole is in the wrong location the performance of the new blade may be adversely affected. See “Possible Problems” below. For tensioning, please follow these instructions.

Correct Pole Location:

When the blade contacts the belt (before tensioning) there should be blade-to-belt contact across the entire blade (Fig. 1). If contact is more in the centre with a gap on the outer edges, the pole will need to be raised until full contact is achieved (Fig. 2). If contact is more on the outer edges with a gap in the centre, the pole will need to be lowered until full contact is achieved (Fig. 3).

Possible Problems:

- Pole location too low - The initial cleaning will be concentrated in the centre of the belt, failing to clean the outer edges efficiently.
- Pole location too high - The initial cleaning will be concentrated to the outer edges of the belt, failing to efficiently clean the centre of the belt.
- Tension too low - Without the optimal tension, the cleaning efficiency is reduced and chatter or bouncing of the blade can occur.
- Tension too high - Although the cleaning may appear efficient, accelerated blade wear may occur; and in some cases less efficiency on the outer edges of the belt, which could result in increased belt wear.

Correct Tensioning:

Correct tension is determined and set by blade width. Check the information provided with the tensioner being used or consult the installation instructions.

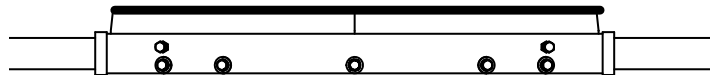

Fig. 1

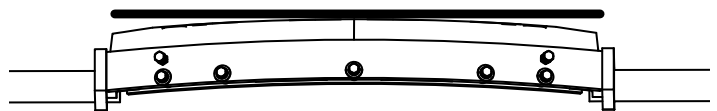

Fig. 2

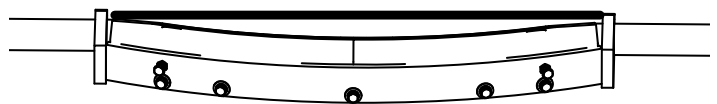
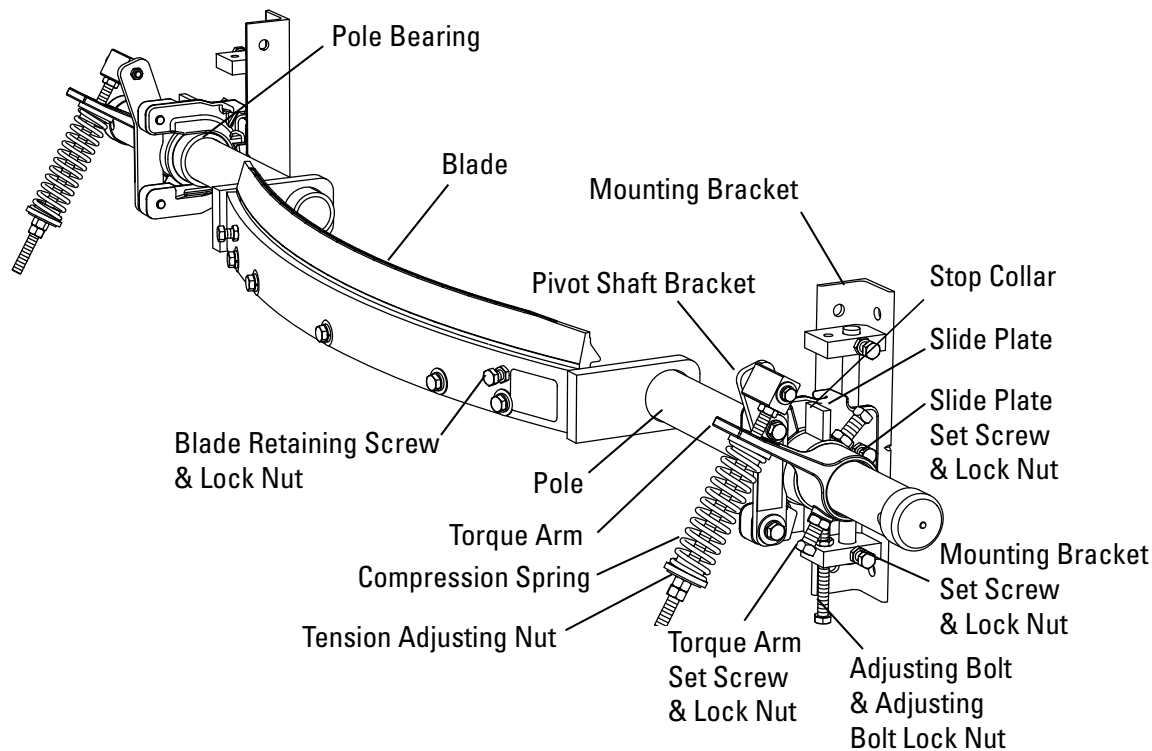

Fig. 3

Section 4 - Installation Instructions

4.1 U-Type® Cleaner



U-Type® with UST Tensioner Parts List

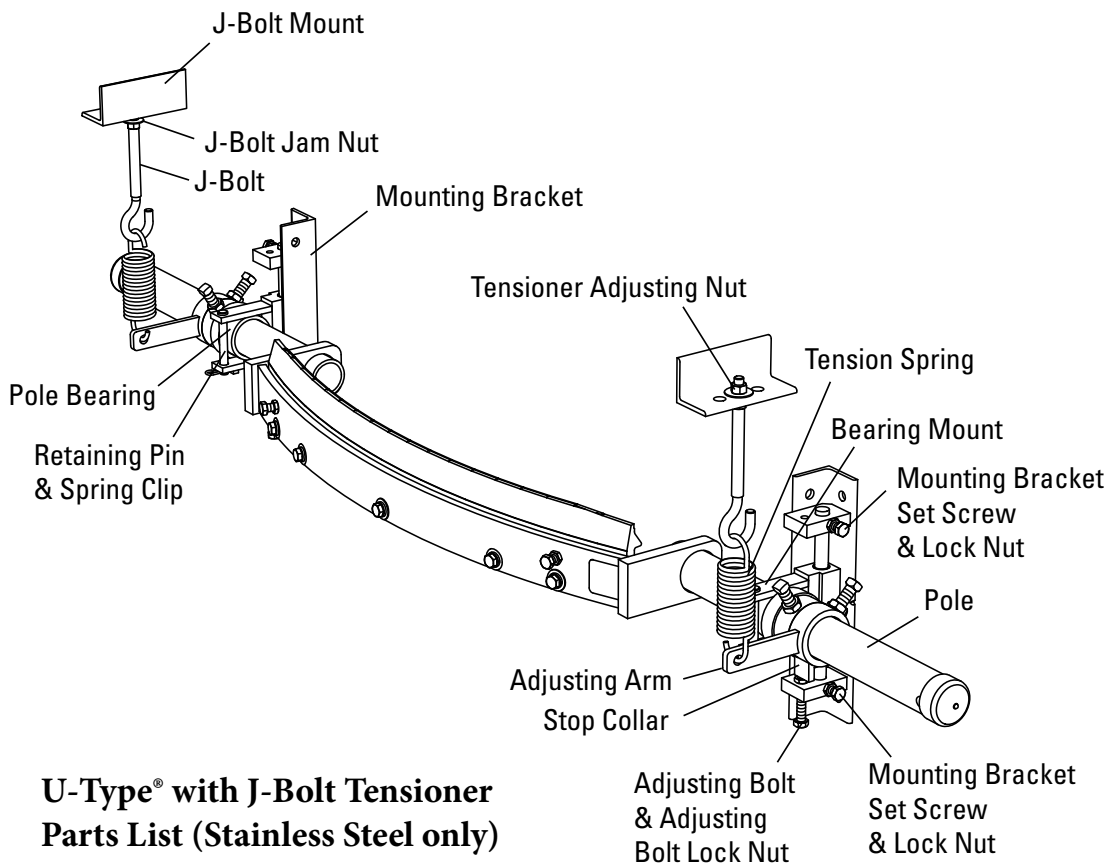

**U-Type® with J-Bolt Tensioner
Parts List (Stainless Steel only)**

Section 4 - Installation Instructions

4.1 U-Type® Cleaner

Physically lock out and tag the conveyor at the power source before you begin cleaner installation.

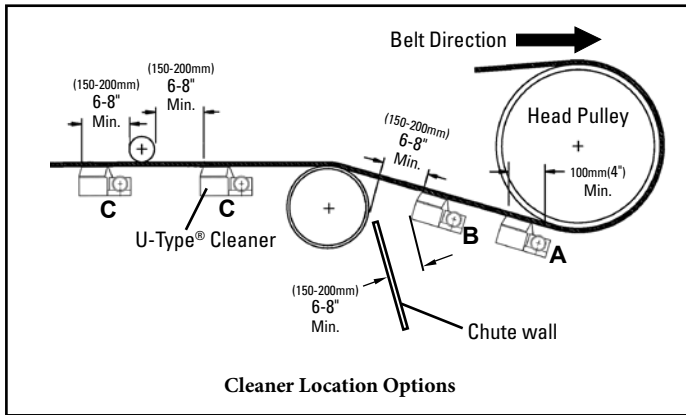

- Tools Needed:**
- Tape measure
 - 19mm (3/4") wrench
 - Ratchet with 19mm (3/4") socket
 - Screwdriver
 - (2) 154mm (6") C-clamps (optional for locating mounting brackets)
 - Level (optional for locating belt height)
 - Permanent marker
 - Cutting torch and/or welder
 - Square (for setting blade parallel to belt)

Before You Begin:

- Double-check the blade type needed for your application:
 F-Blade - for mechanically spliced belts.
 C-Blade - for Flexco Solid Plate mechanically spliced and vulcanized belts.
 V-Blade - for vulcanized belts. Can be used with mechanical splices (solid bolt fasteners) that are recessed (skived) into the belt cover (bolts must be ground on plate fasteners).
- For chute mounting it is necessary to cut an access hole. See access hole dimensions on page 9.
- Follow all safety precautions when using a cutting torch.
- If welding, protect all fastener threads from weld spatter.
- For cleaner clearance requirements see chart below.

Cleaner Clearance Requirements

U Cleaner Size		Clearance	
mm	in.	mm	in.
450	18"	155	6
600	24"	180	7
750	30"	205	8
900	36"	205	8
1050	42"	235	9 1/4
1200	48"	270	10 1/2
1350	54"	275	10 3/4
1500	60"	275	10 3/4
1800	72"	275	10 3/4
2100	84"	275	10 3/4
2400	96"	275	10 3/4

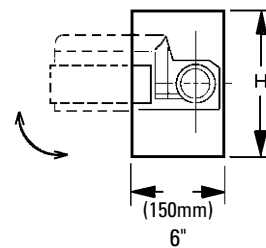
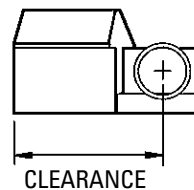

Chute Mounting Access Hole Dimensions

Belt Width	H Dimension
450-1050mm (18" - 42")	200mm (8")
1200-2400mm (48" - 96")	250mm (10")

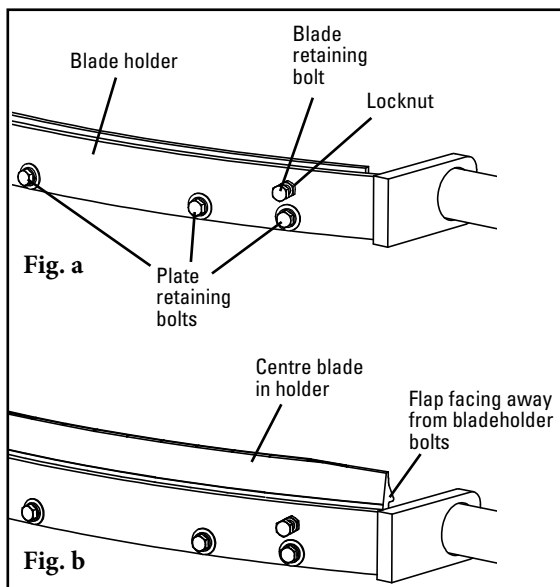

Install the blade in the pole:

- a. Loosen both locknuts on the blade retaining bolts. Turn blade retaining bolts out 8 turns (Fig. a).
- b. Loosen (but do not remove) all plate retaining bolts (Fig. b).
- c. Install the new blade as shown in Fig. b. The flap on the blade should face away from bladeholder screws.
- d. Centre the blade in the holder.
- e. Tighten all plate retaining screws.
- f. Tighten blade retaining screws 8 turns and tighten the blade retaining screw locknuts.

Section 4 - Installation Instructions

4.1 U-Type® Cleaner with UST Tensioner

1. Choose conveyor location where cleaner will be installed.

The U-Type® may be positioned at any spot from where belt leaves head pulley on down the conveyor line (see positions A to B). If a chute area is too small due to a snub pulley, it may be necessary to mount cleaner behind chute (see position C). In chute applications a minimum of 150-200mm (6"-8") is required between cleaner and chute wall to prevent clogging of material.

NOTE: For U-Type® cleaners using UST Tensioners, proceed to steps 2U - 7U.

For U-Types using J-Bolt Tensioners, skip ahead to Steps 2J - 8J.

UST Tensioner Instructions

2U. Install mounting brackets.

- Using a level, lightly raise return side belt (take out cupping or sagging on edges) to find belt's true parallel path to the structure; and mark reference point #1 on structure. Measure down 75mm from reference point #1 and mark reference point #2 (Fig. 2Ua). Make sure brackets are the same distance away from head pulley or a reference point on both sides of the structure. If there is no structure to mount to, install mounting bracket kit first.
- Position mounting brackets so centreline marks on brackets are in line with reference points #2 on the structure (Fig. 2Ub).
- Clamp or weld into position.

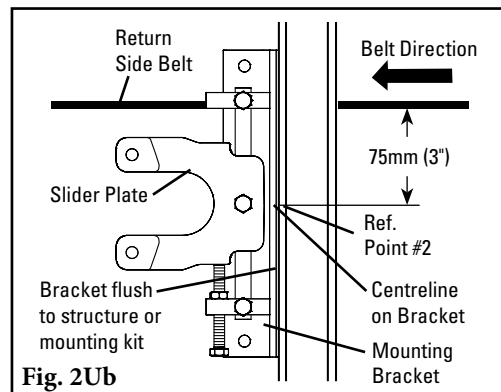
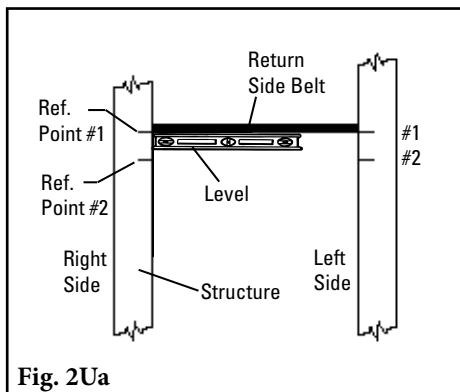

3U. Install the cleaner pole into the slider plates.

- Set pole ends into slider plate on both sides (Fig. 3Ua).
- Slide pole bearings onto both ends of the pole with flange facing away from the belt (Fig. 3Ub).
- Slide stop collar onto both ends of the pole (Fig. 3Ub). Do not tighten at this time.
- Slide torque arms onto both ends of pole and attach both pivot shaft brackets to slider plates (Fig. 3Ub). Blade and torque arm must face either in the direction of belt travel (Fig. 3Uc), or if clearance is an issue, switch to rotated tensioner configuration and assemble as shown (Fig. 3Ud).
- Move slider plate to bottom of bracket to allow blade to rotate up into position in the next steps.

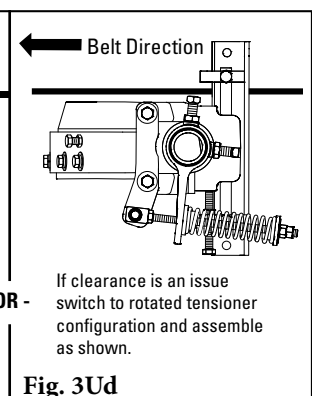
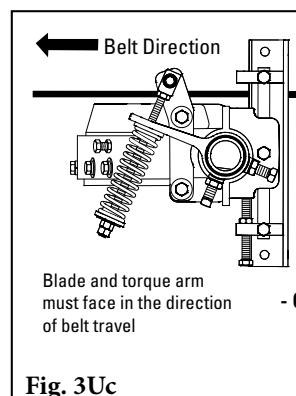
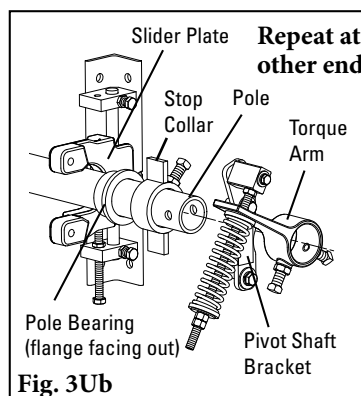
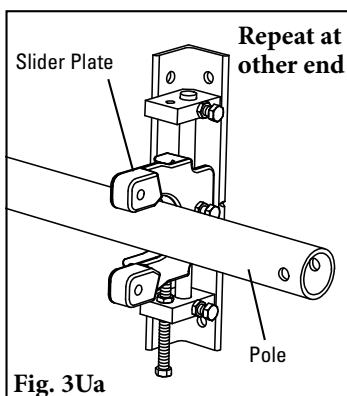

Section 4 - Installation Instructions

4.1 U-Type® Cleaner with UST Tensioner (cont.)

4U. Tighten torque arm set screws.

- Spring tension nuts should be moved near the end of the threaded rod. Insert a screwdriver or small rod through holes on end of cleaner pole. Pushing on screwdriver or rod, rotate cleaner blade into a position with pole parallel to belt (Fig. 4Ua). Blade should not be touching belt at this time. The gap between the torque arm and pivot block should be approximately 50mm (2").
- Centre the blade to the belt and make sure torque arm, stop collar, bearing and slide plate are tight together on both sides. Then tighten stop collar set screw and lock nut with stop collar touching top of bearing mount stop to hold blade parallel to belt, and remove screwdriver or rod.
- Push torque arm down to contact the spring and tighten the torque arm set screws and lock nuts on both sides of the cleaner (Fig. 4Ub).

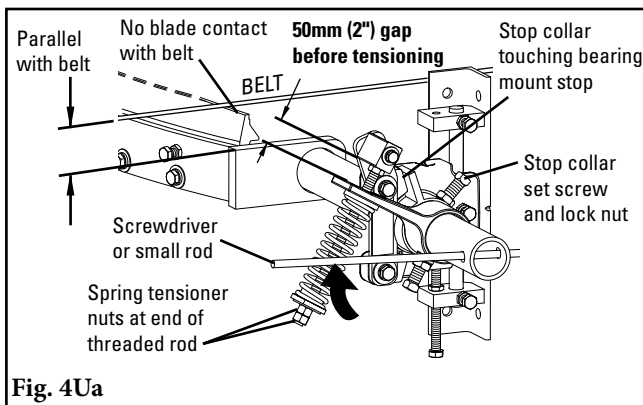

Fig. 4Ua

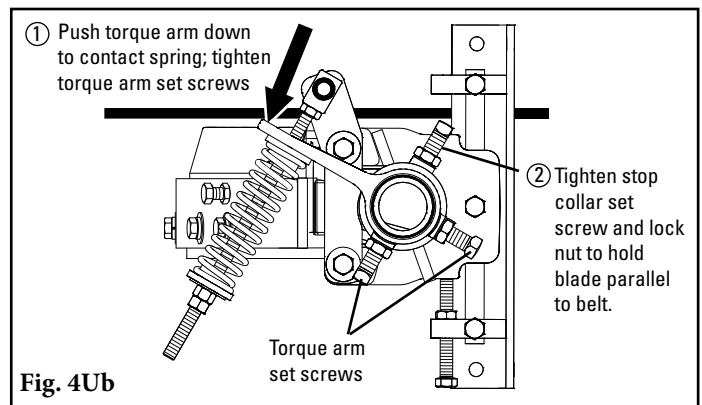

Fig. 4Ub

5U. Adjust the blade to the belt.

- Loosen slide plate set screws and lock nuts. Adjust by turning adjusting bolts either up or down (Fig. 5U).
- Adjust blade either up or down until both blade ends and the centre make full contact with belt. If possible, adjust both sides of the cleaner up to the belt at the same time for even blade contact across belt (reduces chance of overtensioning on one side).

IMPORTANT: In some cases, due to irregular belt wear or cupping, it may be necessary to make final adjustments independently on both sides.

- Tighten lock nuts on adjusting bolts to secure blade in correct position. Also tighten slide plate set screws and lock nuts.

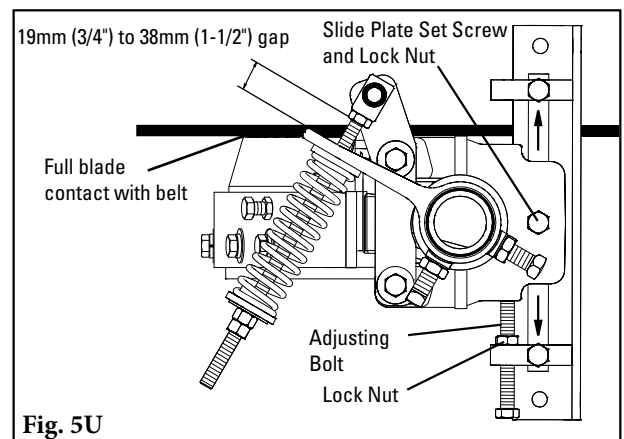

Fig. 5U

Adjusting Nuts
Top of washer to top of torque arm

Spring Length Chart (for Cleaners with UST Tensioners)							
Blade Width		Purple Spring		Silver Spring		White Spring	
mm	in.	mm	in.	mm	in.	mm	in.
450	18	143	5 5/8	—	—	—	—
600	24	133	5 1/4	152	6	—	—
750	30	117	4 5/8	146	5 3/4	156	6 1/8
900	36	108	4 1/4	143	5 5/8	152	6
1050	42	—	—	133	5 1/4	146	5 3/4
1200	48	—	—	124	4 7/8	140	5 1/2
1350	54	—	—	117	4 5/8	137	5 3/8
1500	60	—	—	—	—	133	5 1/4
1800	72	—	—	—	—	124	4 7/8
2100	84	—	—	—	—	117	4 5/8

Fig. 6U

6U. Set the blade tension.

- Set spring length to determined length (Fig. 6U). Tighten spring tension nuts on threaded rod.
IMPORTANT: Always be sure there is uniform contact between blade and belt.
- If blade is not in full contact with belt at edges and centre, either raise or lower pole position of cleaner and reapply tension.
- Please note, when fully tensioned there should be approximately 19mm to 38 mm (3/4" to 1-1/2") of space between the torque arm and pivot block (Fig. 5U).

Section 4 - Installation Instructions

4.1 U-Type® Cleaner with UST Tensioner (cont.)

7U. Set the blade travel stop.

Set both stop collars to a clearance of 6mm (1/4") between stop collar and bottom bearing mount stop for UV and UC cleaners, or 13mm (1/2") for UF cleaners (Fig. 7U). This is to prevent blade from moving into belt. Tighten set screws and lock nuts.

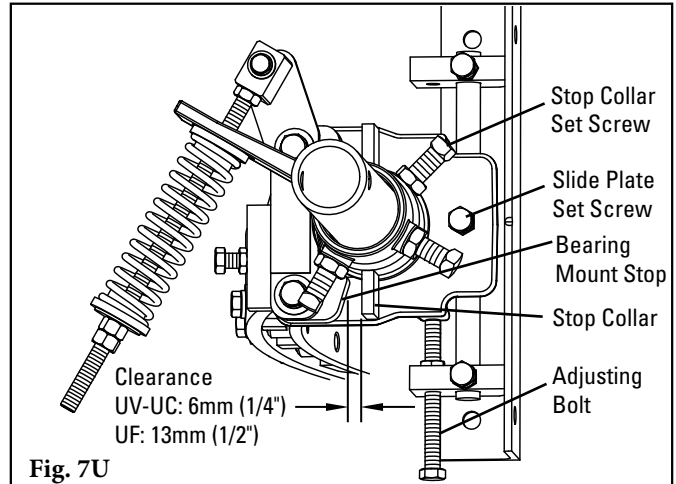

4.2 U-Type SS J-Bolt Cleaner

J-Bolt Tensioner Instructions - For Stainless Steel Cleaners

2J. Install the mounting brackets onto the structure.

- Using a square, lightly raise return side belt (take out cupping or sagging on edges) to find belt's true parallel path to the structure; and mark reference point #1 on the structure on both sides of the conveyor. Measure down 84mm (3-3/8") from reference point #1 on both sides and mark reference point #2 (Fig. 2Ja).
- Position the mounting brackets so the centreline marks on the brackets are in line with reference points #2 on the structure (Fig. 2Jb).
- Clamp or weld into position.

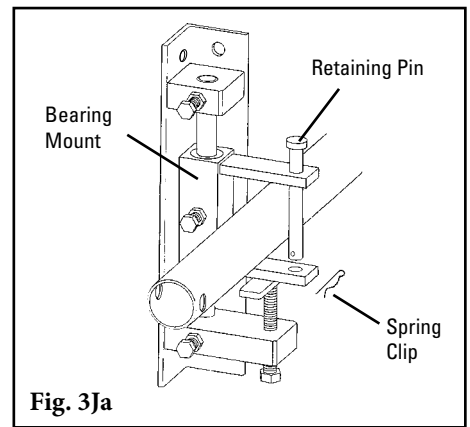
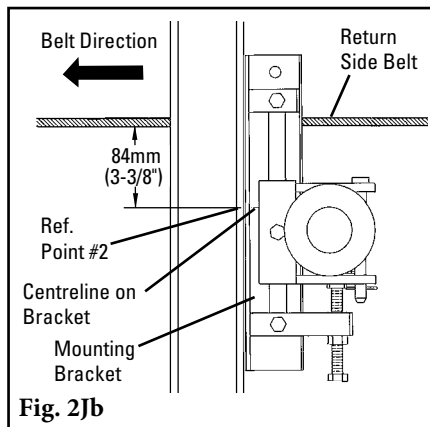
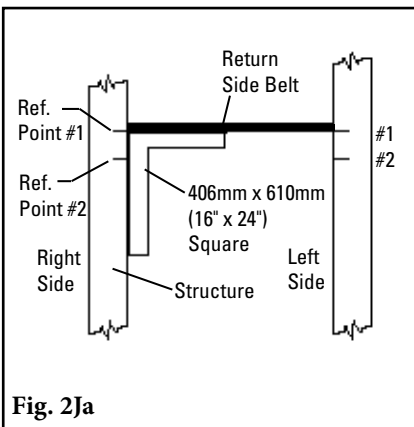

3J. Install cleaner pole into bearing mounts in both mounting brackets.

- Remove nylon bearings from both bearing mounts. Remove spring clip and pull retaining pin out of one bearing mount. Slide cleaner pole into bearing mount on the opposite side and then position it into bearing mount where retaining pin was removed. Reinsert retaining pin and lock into place with spring clip (Fig. 3Ja).
- Slide a nylon bearing onto each pole end with flanged end facing away from belt. Nylon bearing will fit snugly into bearing mount (Fig. 3Jb).
- Position the pole so that blade is centred to belt. With blade centred, draw a line around pole at nylon bearing. This line can be used as a reference point to ensure the pole/blade remains centred to belt while other steps are completed.

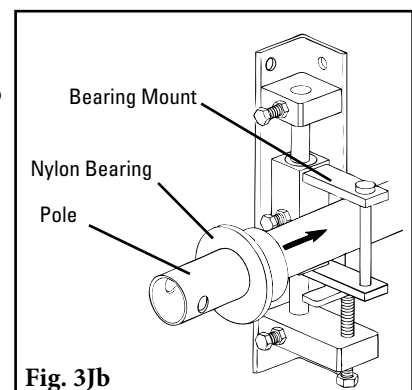

Section 4 - Installation Instructions

4.2 U-Type® SS J-Bolt Cleaner (cont.)

4J. Install the stop collars.

- Slide one stop collar onto the most convenient pole end (Fig. 4Ja).
- Insert a screwdriver or small rod into hole on end of cleaner pole. Pushing on the rod, move blade into a position parallel to belt (Fig. 4Jb). Blade should not be touching belt at this time.
- Tighten stop collar set screw and lock nut to hold blade parallel to belt and remove screwdriver or rod.
- Install second stop collar on other pole end. Do not tighten set screw and lock nut at this time.

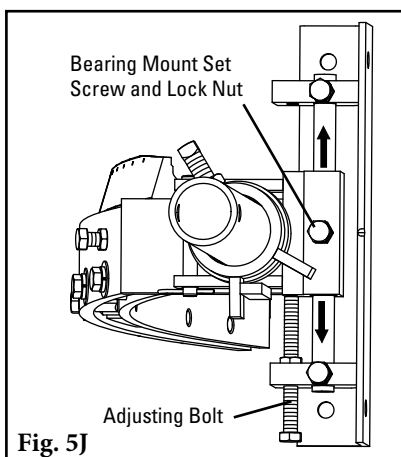
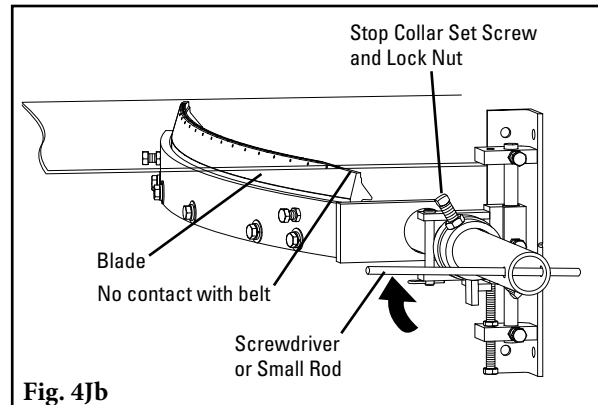
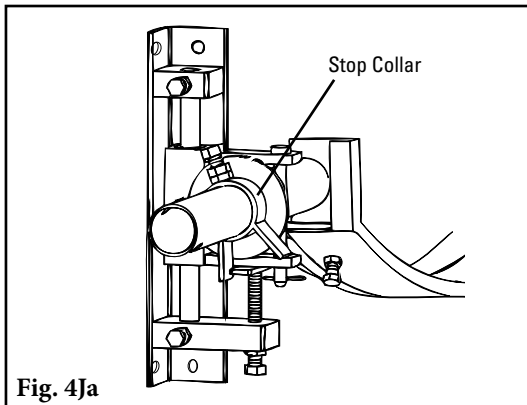

5J. Adjust blade to belt.

- Loosen bearing mount set screws and lock nuts. Adjustments will be made by turning adjusting bolts either up or down (Fig. 5J).
- Adjust blade either up or down until both blade ends and the centre make full contact with belt.
IMPORTANT: In some cases, due to irregular belt wear or cupping, it may be necessary to make final adjustments independently on both sides.
- Tighten lock nuts on adjusting bolts to secure blade in correct position. Also tighten bearing mount set screws and lock nuts.

Section 4 - Installation Instructions

4.2 U-Type® SS J-Bolt Cleaner (cont.)

6J. Mount the tensioning system.

- Slide one adjusting arm onto pole end with stop collar that was not tightened (Fig. 6Ja).
- Assemble tension spring and J-bolt mount to adjusting arm. Locate position for J-bolt mount (Fig. 6Jb).
IMPORTANT: Allow at least 50mm (2") of upward movement for J-bolt end for future adjustment.
- The J-bolt mount can be mounted in any position (360 degrees) around pole. The only requirement is that J-bolt and spring remain perpendicular to adjusting arm (Fig. 6Jc).
- Weld or bolt J-bolt mount into position.
- Tighten adjusting arm set screw and lock nut to secure position on pole.
- Adjust J-bolt to apply light tension on tension spring.

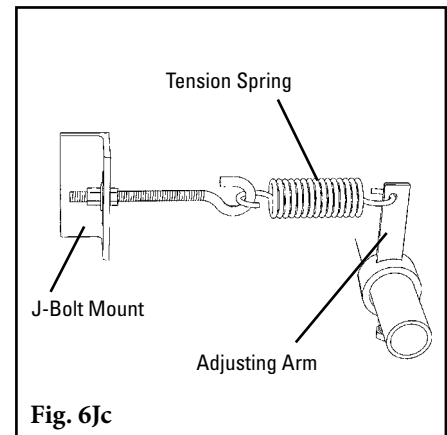
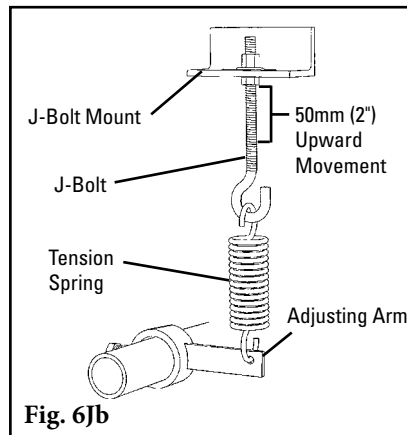
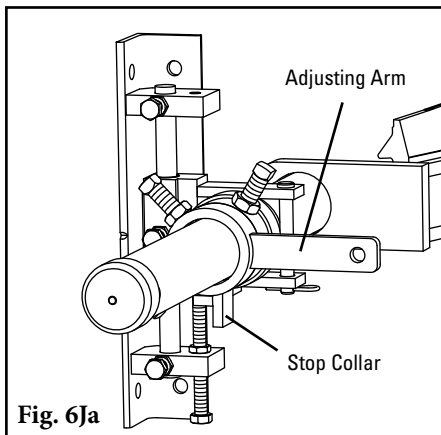

7J. Set up stop collar and assemble opposite tensioning system.

- Loosen stop collar (Fig. 7J).
- Slide the second adjusting arm on pole end; assemble and mount tensioning system.

8J. Set the spring tension.

- Loosen J-bolt jam nuts and turn tensioner adjusting nuts until both springs have a clearance of about .7mm (.030") between all coils (use Spring Tension Gauge included in installation instruction packet.) (Fig. 8J).
IMPORTANT: Always be sure there is uniform contact between blade and belt.
- If blade is not in full contact with belt at edges and centre, either raise or lower pole position of cleaner and reapply tension.

9J. Set the blade travel stop.

Set both stop collars to a clearance of 6mm (1/4") for UV and UC cleaners, or 13mm (1/2") for UF cleaners, from bearing mount stops (Fig. 9J). This is to prevent blade from moving into belt. Tighten set screws and lock nuts.

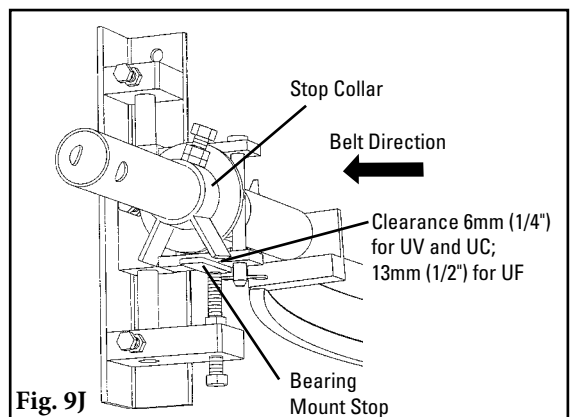
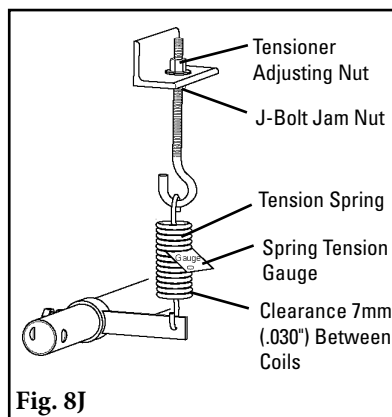
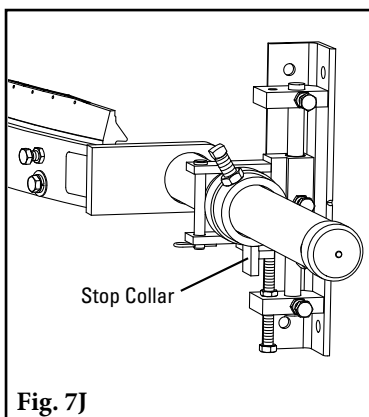

Section 5 - Pre-Operation Checklist and Testing

5.1 Pre-Op Checklist

- Recheck that all fasteners are tightened properly
- Add pole caps
- Apply all supplied labels to the cleaner
- Check the blade location on the belt
- Be sure that all installation materials and tools have been removed from the belt and the conveyor area

5.2 Test Run the Conveyor

- Run the conveyor for at least 15 minutes and inspect the cleaning performance
- Check the tensioner spring for recommended length (proper tensioning)
- Make adjustments as necessary

NOTE: Observing the cleaner when it is running and performing properly will help to detect problems or when adjustments are needed later.

Section 6 - Maintenance

Flexco belt cleaners are designed to operate with minimum maintenance. However, to maintain superior performance some service is required. When the cleaner is installed a regular maintenance program should be set up. This program will ensure that the cleaner operates at optimal efficiency and problems can be identified and fixed before the cleaner stops working.

All safety procedures for inspection of equipment (stationary or operating) must be observed. The U-Type® Belt Cleaner operates at the discharge end of the conveyor and is in direct contact with the moving belt. Only visual observations can be made while the belt is running. Service tasks can be done only with the conveyor stopped and by observing the correct lockout/tagout procedures.

6.1 New Installation Inspection

After the new cleaner has run for a few days a visual inspection should be made to ensure the cleaner is performing properly. Make adjustments as needed.

6.2 Routine Visual Inspection (every 2-4 weeks)

A visual inspection of the cleaner and belt should look for:

- If spring length is the correct length for optimal tensioning
- If spring gap is correct for optimal tensioning (for J-Bolt tensioners)
- If belt looks clean or if there are areas that are dirty
- If blade is worn out and needs to be replaced
- If there is damage to the blade or other cleaner components
- If fugitive material is built up on cleaner or in the transfer area
- If there is cover damage to the belt
- If there is vibration or bouncing of the cleaner on the belt
- If a snub pulley is used, a check should be made for material buildup on the pulley
- Significant signs of carryback

If any of the above conditions exist, a determination should be made on when the conveyor can be stopped for cleaner maintenance.

6.3 Routine Physical Inspection (every 6-8 weeks)

When the conveyor is not in operation and properly locked and tagged out, a physical inspection of the cleaner to perform the following tasks:

- Clean material buildup off of the cleaner blade and pole
- Closely inspect the blade for wear and any damage. Replace if needed.
- Ensure full blade to belt contact
- Inspect the cleaner pole for damage
- Inspect all fasteners for tightness and wear. Tighten or replace as needed.
- Replace any worn or damaged components
- Check the tension of the cleaner blade to the belt. Adjust the tension if necessary using the chart on the cleaner or the one on Page 18. For J-bolt Tensioners, use the spring tension gauge to set a .7mm (.030") gap between spring coils.
- When maintenance tasks are completed, test run the conveyor to ensure the cleaner is performing properly

Section 6 - Maintenance

6.4 Blade Replacement Instructions

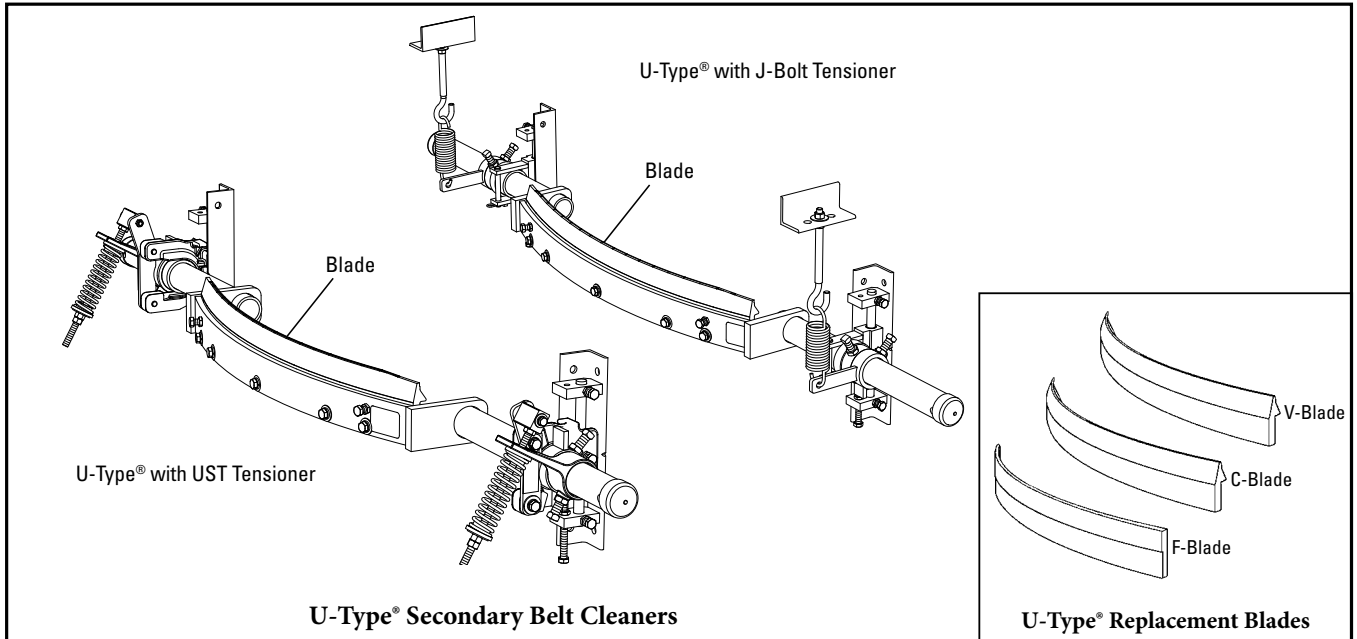

Physically lock out and tag the conveyor at the power source before you begin cleaner installation.

Tools Needed:

- Tape measure
- 19mm (3/4") wrench
- Wire brush

Double check the blade type needed for your application:

F- Blade - for mechanically-spliced belts

C-Blade - for Flexco Solid Plate mechanically spliced and vulcanized belts

V-Blade - for vulcanized belts. Can be used with mechanical splices (solid bolt fasteners) that are recessed (skived) into the belt cover (bolts must be ground on plate fasteners)

1. Release the blade tension.

UST Spring Tensioner: Loosen the tension adjusting nuts on the tensioner pivot rods, allowing the pole to rotate the blade down (Fig. 1a).

J-Bolt Tensioner: Loosen both J-bolt jam nuts and remove the tensioner adjusting nuts and flat washers, allowing the pole to rotate against the stop collar and the blade to rotate down (Fig. 1b).

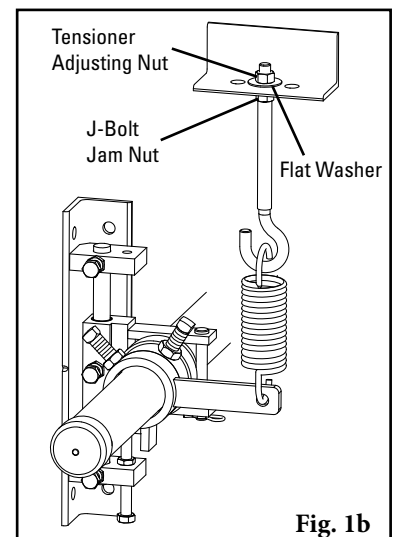
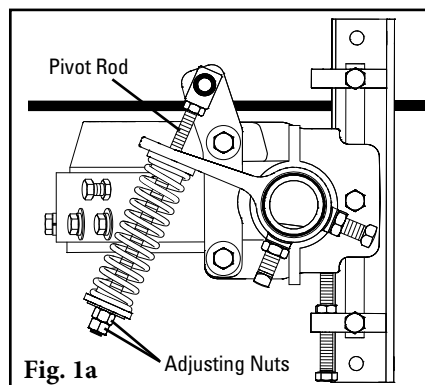

Section 6 - Maintenance

2. Remove the worn blade.

- Loosen both locknuts on the blade retaining screws. Turn blade retaining screws out 8 turns (Fig. 2a).
- Loosen or remove all plate retaining screws.
- From one end, insert a screwdriver under the blade and lightly pry the blade up and out of the blade holder (Fig. 2b). Once the blade breaks free, pull it out by hand.
- Remove the blade from the holder and clean material buildup from holder with a wire brush (Fig. 2c).

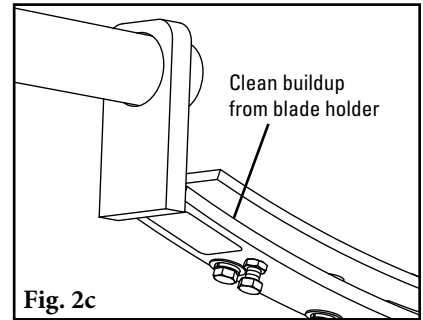
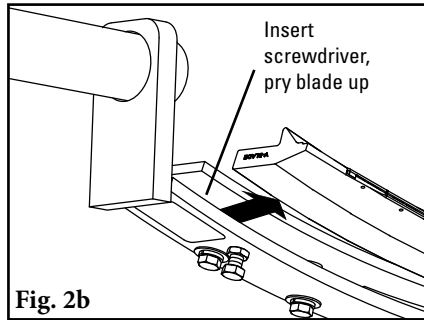
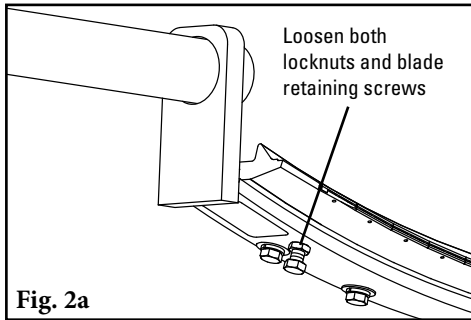

Fig. 2a

Fig. 2b

Fig. 2c

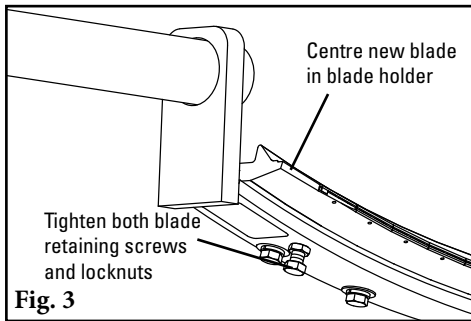

Fig. 3

3. Install the new blade.

- Centre the blade in the holder (Fig. 3).
- Tighten all plate retaining screws.
- Tighten blade retaining screws 8 turns and tighten the blade retaining screw locknuts (Fig 3).

4. Reset the blade tension.

UST Spring Tensioner: Refer to the chart for the spring length required for the belt width. Lightly pull the pivot arm toward the end of the torque arm slot nearest the pole and turn the adjusting nuts until the required spring length is achieved (Fig. 4a). **NOTE:** The chart is also on the cleaner's pivot shaft bracket for future reference for retensioning maintenance. Reference Section 4 (Cleaner Installation Instructions) on page 8.

J-Bolt Tensioner: Rotate the pole and insert the J bolts through the J bolt mount holes and install the flat washers and tensioner adjusting nuts. Turn the tensioner adjusting nuts until a .7mm (.030") gap (use Spring Tension Gauge included with cleaner) appears between all coils of the tension spring (Fig. 4b). Lock both J bolt jam nuts.

Adjusting Nuts

Top of washer to top of torque arm

Blade Width		Purple Spring		Silver Spring		White Spring	
mm	in.	mm	in.	mm	in.	mm	in.
450	18	143	5 5/8	—	—	—	—
600	24	133	5 1/4	152	6	—	—
750	30	117	4 5/8	146	5 3/4	156	6 1/8
900	36	108	4 1/4	143	5 5/8	152	6
1050	42	—	—	133	5 1/4	146	5 3/4
1200	48	—	—	124	4 7/8	140	5 1/2
1350	54	—	—	117	4 5/8	137	5 3/8
1500	60	—	—	—	—	133	5 1/4
1800	72	—	—	—	—	124	4 7/8
2100	84	—	—	—	—	117	4 5/8

Fig. 4a

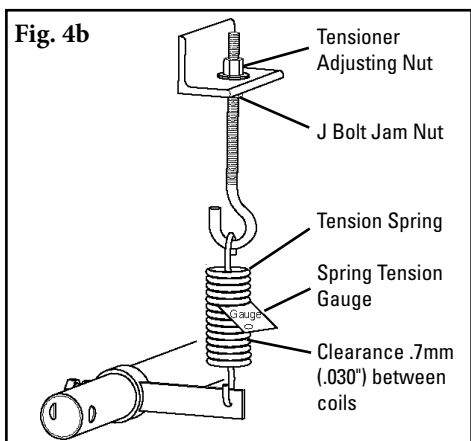

Fig. 4b

- Inspect for full blade contact to the belt.** Important - Always be sure there is uniform contact between the blade and the belt. If the blade is not in full contact with the belt at the edges and centre, raise or lower the pole position of the cleaner and reapply the tension (See Installation Instructions).

Test run the cleaner. Run the conveyor for at least 15 minutes and inspect the cleaning performance. Check the spring length for proper tensioning. Make adjustments as necessary.

Section 6 - Maintenance

6.5 Maintenance Log

Conveyor Name/No. _____

Date: _____ Work done by: _____ Service Quote #: _____

Activity: _____

Date: _____ Work done by: _____ Service Quote #: _____

Activity: _____

Date: _____ Work done by: _____ Service Quote #: _____

Activity: _____

Date: _____ Work done by: _____ Service Quote #: _____

Activity: _____

Date: _____ Work done by: _____ Service Quote #: _____

Activity: _____

Date: _____ Work done by: _____ Service Quote #: _____

Activity: _____

Date: _____ Work done by: _____ Service Quote #: _____

Activity: _____

Date: _____ Work done by: _____ Service Quote #: _____

Activity: _____

Section 6 - Maintenance

6.6 Cleaner Maintenance Checklist

Belt Cleaner: _____ **Serial Number:** _____

Beltline Information:

Beltline Number: _____ Belt Condition: _____

- Belt Width: 450mm (18") 600mm (24") 750mm (30") 900mm (36") 1050mm (42") 1200mm (48") 1350mm (54") 1400mm (56")
- 1500mm (60") 1600mm (64") 1800mm (72") 2000mm (80") 2100mm (84") 2200mm (88") 2400mm (96") 2500mm (98")

Head Pulley Diameter (Belt & Lagging): _____ Belt Speed: _____ fpm Belt Thickness: _____

Belt Splice: _____ Condition of Splice: _____ Number of Splices: _____ Skived Unskived

Material conveyed: _____

Days per week run: _____ Hours per day run: _____

Blade Life:

Date blade installed: _____ Date blade inspected: _____ Estimated blade life: _____

Is blade making complete contact with belt? Yes No

Distance from wear line: Left _____ Middle _____ Right _____

Blade condition: Good Grooved Smiled Not contacting belt Damaged

Measurement of spring: Required _____ Currently _____

Was Cleaner Adjusted: Yes No

Pole Condition: Good Bent Worn

Lagging: Side Lag Ceramic Rubber Other None

Condition of lagging: Good Bad Other _____

Cleaner's Overall Performance: (Rate the following 1 - 5, 1= very poor - 5 = very good)

Appearance: Comments: _____

Location: Comments: _____

Maintenance: Comments: _____

Performance: Comments: _____

Other comments _____

Section 7 - Troubleshooting

Problem	Possible Cause	Possible Solutions
Vibration	Cleaner secure bolts not set	Ensure all locking nuts are tight (Loctite)
	Cleaner not set up correctly	Ensure cleaner set up properly (1°-3° into belt)
	Belt tension too high	Ensure cleaner can conform to belt, or replace with alternate Flexco secondary cleaner
	Belt flap	Introduce hold-down roller to flatten belt
	Cleaner over-tensioned	Ensure cleaner is correctly tensioned
	Cleaner under-tensioned	Ensure cleaner is correctly tensioned
	Nylon bearing worn out or missing	Replace nylon bearing
Material buildup on cleaner	Cleaner not set up correctly	Ensure cleaner set up properly (1°-3° into belt)
	Buildup on chute	Ensure cleaner is not located too close to back of chute, allowing buildup
	Cleaner being overburdened	Introduce Flexco primary cleaner
	Excessive sticky material	Frequently clean unit of buildup
Damaged belt cover	Cleaner over-tensioned	Ensure cleaner is correctly tensioned
	Cleaner blade damage	Check blade for wear, damage and chips, replace where necessary
	Attack angle not correct	Ensure cleaner set up properly (1°-3° into belt)
	Material buildup in chute	Frequently clean unit of buildup
	Stop collar in incorrect position	Check stop collar tabs are not resting against slide plate
Cleaner not conforming to belt	Cleaner not set up correctly	Ensure cleaner set up properly (1°-3° into belt)
	Belt tension too high	Ensure cleaner can conform to belt, or replace with alternate Flexco secondary cleaner
	Belt flap	Introduce hold-down roller to flatten belt
	Cleaner cannot conform	Ensure cleaner can conform to belt, or replace with alternate Flexco secondary cleaner
Material passing cleaner	Cleaner not set up correctly	Ensure cleaner set up properly (1°-3° into belt)
	Cleaner tension too low	Ensure cleaner is correctly tensioned
	Cleaner blade worn/damaged	Check blade for wear, damage and chips, replace where necessary
	Cleaner being overburdened	Introduce Flexco primary cleaner
	Belt flap	Introduce hold-down roller to flatten belt
	Cleaner cannot conform	Ensure cleaner can conform to belt, or replace with alternate Flexco secondary cleaner
	Blade in backwards	Install blade correctly and set correct tension
	Stop collar in incorrect position	Check stop collar tabs are not resting against slide plate
Damage to mechanical fastener	Incorrect cleaner blade selection	Change blade type to accommodate fastener style (UC or UF)
	Belt not skived correctly	Spot and redo splice correctly, lowering the profile flush or below belt surface
	Stop collar in incorrect position	Check stop collar tabs are not resting against slide plate
Missing material in belt centre only	Cleaner pole located too high	Ensure cleaner set up properly (1°-3° into belt)
	Cleaner blade worn/damaged	Check blade for wear, damage and chips, replace where necessary
Missing material on outer edges only	Cleaner pole located too low	Ensure cleaner set up properly (1°-3° into belt)
	Cleaner blade worn/damaged	Check blade for wear, damage and chips, replace where necessary

Section 8 - Specs and CAD Drawings

8.1 Specifications and Guidelines

Pole Length Specifications

Cleaner Size		Pole Length		Maximum Conveyor Span	
mm	in.	mm	in.	mm	in.
450	18	1600	64	1350	54
600	24	1750	70	1500	60
750	30	1900	76	1650	66
900	36	2050	82	1800	72
1050	42	2200	88	1950	78
1200	48	2350	94	2100	84
1350	54	2500	100	2250	90
1500	60	2650	106	2400	96
1800	72	3100	124	2850	114
2100	84	3400	136	3150	126
2400	96	3700	148	3450	138

Pole Diameter - 450mm to 1350mm (18" to 54") cleaners: 60mm (2-3/8")
 Pole Diameter - 1500mm to 2400mm (60") and 96" cleaners: 75mm (2-7/8")

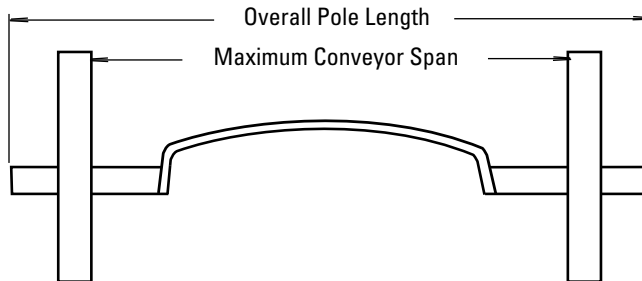

Cleaner Clearance Requirements

U Cleaner Size		Clearance	
mm	in.	mm	in.
450	18"	155	6
600	24"	180	7
750	30"	205	8
900	36"	205	8
1050	42"	235	9 1/4
1200	48"	270	10 1/2
1350	54"	275	10 3/4
1500	60"	275	10 3/4
1800	72"	275	10 3/4
2100	84"	275	10 3/4
2400	96"	275	10 3/4

Spring Length Chart (for Cleaners with UST Tensioners)

Blade Width		Purple Spring		Silver Spring		White Spring	
mm	in.	mm	in.	mm	in.	mm	in.
450	18	143	5 5/8	—	—	—	—
600	24	133	5 1/4	152	6	—	—
750	30	117	4 5/8	146	5 3/4	156	6 1/8
900	36	108	4 1/4	143	5 5/8	152	6
1050	42	—	—	133	5 1/4	146	5 3/4
1200	48	—	—	124	4 7/8	140	5 1/2
1350	54	—	—	117	4 5/8	137	5 3/8
1500	60	—	—	—	—	133	5 1/4
1800	72	—	—	—	—	124	4 7/8
2100	84	—	—	—	—	117	4 5/8

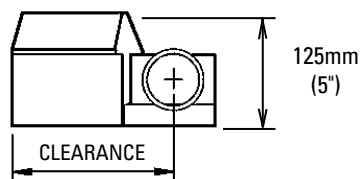
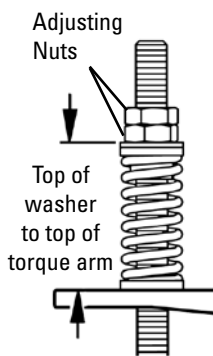

Spring Tensioner Guidelines

(For Stainless Steel Cleaners with J-Bolt Tensioners)

- Spring gap = .7mm (.030")
- *Gauge provided

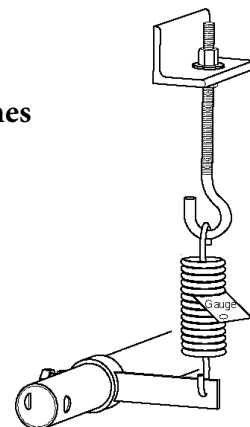

Specifications:

- Maximum Belt Speed..... 6.6m/s (1300 FPM); F-Blade - 5m/s (1000 FPM)
- Temperature Rating..... -35°C to 82°C (-30°F to 180°F)
- Usable Blade Wear Length..... V-Blade and C-Blade - 9mm (3/8"); F-Blade - 44mm (1 3/4")
- Available for Belt Widths..... 450 to 2400mm (18" to 96").
Other sizes available upon request.
- CEMA Class Rating..... Class 5

Section 8 - Specs and CAD Drawings

8.2 CAD Drawing - U-Type® Cleaners with UST Tensioners

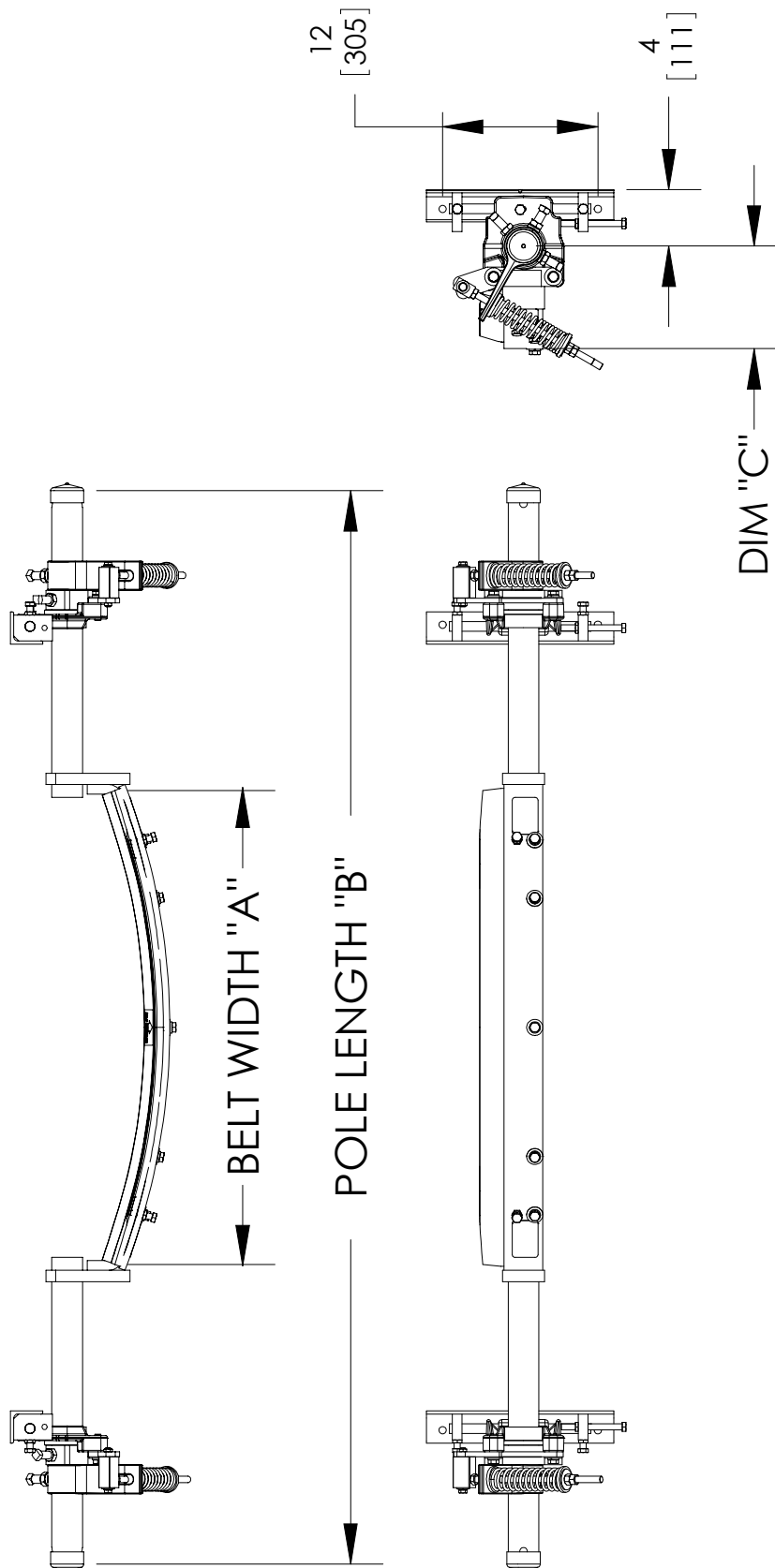

Section 8 - Specs and CAD Drawings

8.2 CAD Drawing - U-Type® Cleaners with J-Bolt Tensioners

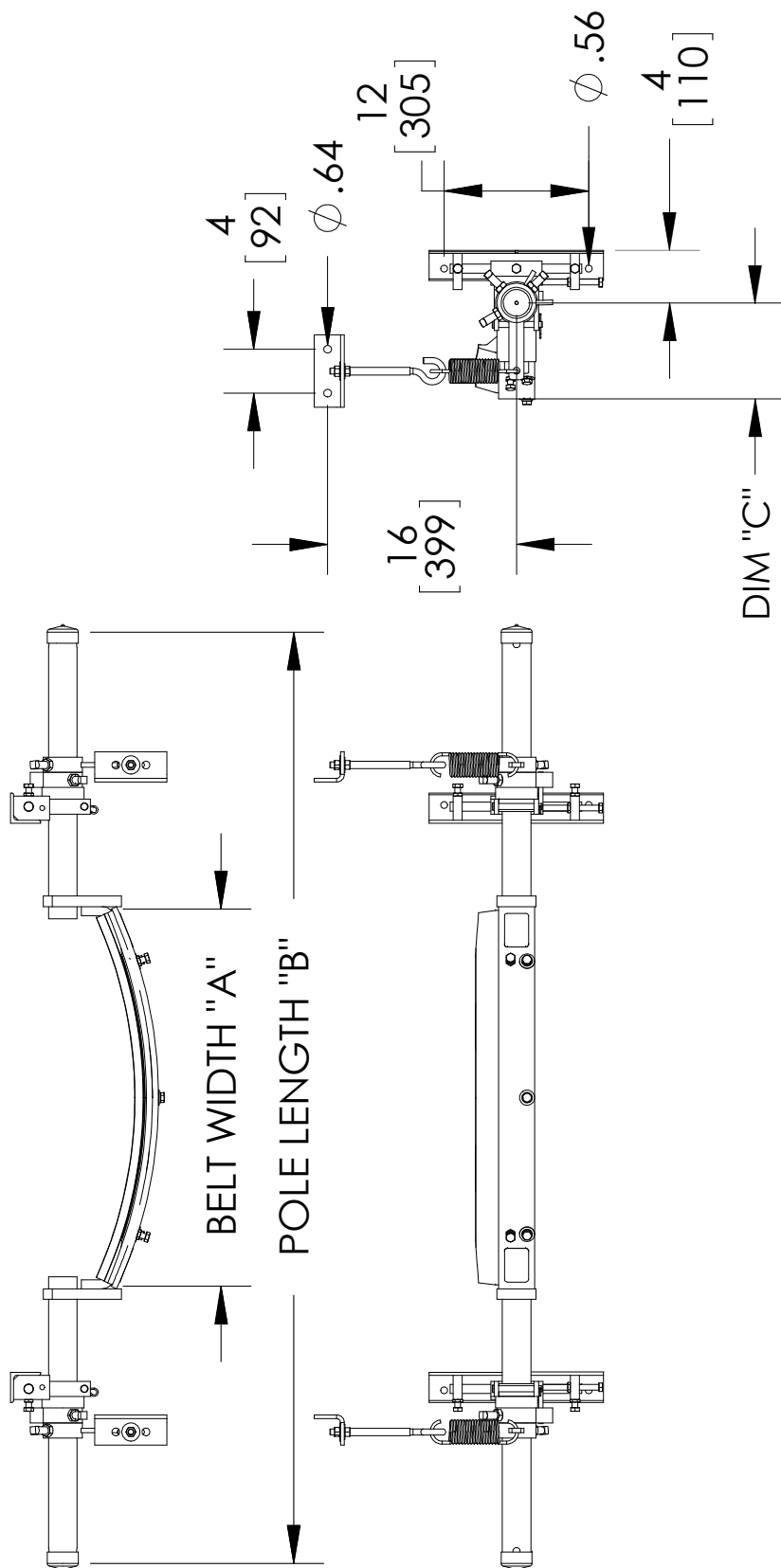

Section 9 - Replacement Parts

9.1 Replacement Parts List - U-Type®

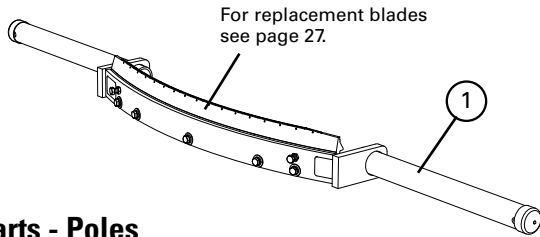

Replacement Parts - Poles

REF	DESCRIPTION	ORDERING NUMBER	ITEM CODE	WT. KG.
1	450mm Pole	USP18/450	82689	18.6
	600mm Pole	USP24/600	82690	20.1
	750mm Pole	USP30/750	82691	21.6
	900mm Pole	USP36/900	82692	23.2
	1050mm Pole	USP42/1050	82693	24.8
	1200mm Pole	USP48/1200	82694	26.3
	1350mm Pole	USP54/1350	82695	27.9
	1400mm Pole	USP56/1400	82696	28.4
	1500mm Pole	USP60/1500	82697	29.5
	1600mm Pole	USP64/1600	82698	30.5
	1800mm Pole	USP72/1800	82699	32.6
	2000mm Pole	USP80/2000	82700	34.6
	2100mm Pole	USP84/2100	82701	35.7
	2200mm Pole	USP88/2200	82702	36.7
	2400mm Pole	USP94/2400	82703	38.3
2500mm Pole	USP98/2500	82704	39.4	

For shaded items please contact Flexco for lead times.

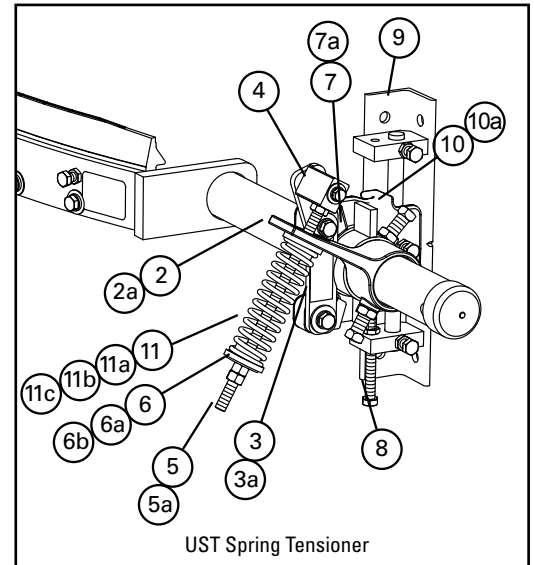

UST Spring Tensioner

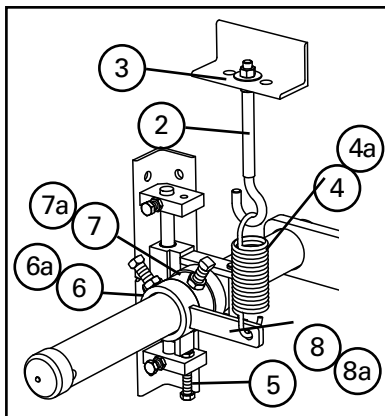

For use in changing UST Spring Tensioner to a J-Bolt Tensioner

Replacement Parts - UST Tensioner

REF	DESCRIPTION	ORDERING NUMBER	ITEM CODE	WT. KG.
2	Torque Arm Kit (1 ea.)	ESTAK	76406	1.6
2A	Torque Arm Kit HD (1 ea.)	C-PSTA	81045	5.2
3	Pivot Shaft Bracket Kit (1 ea.)	MUPSBK	82896	0.8
3A	Pivot Shaft Bracket Kit HD (1 ea.)	QMTPSBK-CN	82182	2.0
4	Pivot Block Kit (1 ea.)	MESPBL	87895	0.5
5	Pivot Rod Kit (1 ea.)	MESPKR	81896	0.5
5A	Pivot Rod Kit HD (1 ea.)	PTPK-MT	82343	2.0
6	EST Bush Kit P&S MET	MESBK-PS	82364	0.05
6A	QMT Bush Kit W&S MET	QMTBK-WS-MT	82175	0.05
6B	QMT Bush Kit G MET	QMTBK-GCN	82174	0.05
7	Standard Pole Bearing (1 ea.)	USPB2	79206	0.05
7A	HD Pole Bearing (1 ea.)	UHPB2	79207	0.1
8	Adjusting Bolt Kit (1 ea. incl. lock nut)	ABU	76788	0.1
9	Mounting Bracket Kit (1 ea. incl. L & R)	UMBK-M	82890	4.4
10	Slide Plate Kit (1 ea.)	USPK	76790	2.1
10A	HD Slide Plate Kit (1 ea.)	UHSPK-M	82887	2.4
11	Tension Spring Purple (1 ea.)	QMTS-P	75845	0.3
11A	Tension Spring Silver (1 ea.)	ESS-S	76412	0.5
11B	Tension Spring White (1 ea.)	PSTS-W	75898	0.8
11C	Tension Spring Gold (1 ea.)	QMT-G	76484	0.8
-	UST Spring Tensioner Mounting Kit* - Purple (Incl. 1 ea. Items 2, 3, 4, 5, 6, 8, 9, 10 & 11)	UST-P-MT	82897	9.5
-	UST Spring Tensioner Mounting Kit* - Silver (Incl. 1 ea. Items 2A, 4, 5A, 6A, 8, 9, 10A & 11A)	UST-S-MT	82898	13.1
-	Heavy-Duty UST Spring Tensioner* - White (Incl. 1 ea. Items 2A, 4, 5A, 6A, 8, 9, 10A & 11B)	UST-W-MT	82899	16.7
-	Heavy-Duty UST Spring Tensioner* - Gold (Incl. 1 ea. Items 2A, 4, 5A, 6A, 8, 9, 10A & 11C)	UST-G-MT	82900	16.7

*Hardware included

Note: For belt widths equal to and larger than 1500mm use heavy-duty components.

Replacement Parts - J-bolt Tensioner

REF	DESCRIPTION	ORDERING NUMBER	ITEM CODE	WT. KG.
2	J-Bolt Kit* (incl. locknut and washer)	STJK-S/S	74417	0.3
3	J-Bolt Mount (1 ea.)	STJM	74775	1.4
4	450-1350mm Tension Spring (1 ea.)	STTS	74419	0.5
4a	1500 mm+ Tension Spring (1 ea.)	HDS	74502	0.7
5	Adjusting Bolt Kit (incl. locknut)	ABU	76788	0.5
6	450-1350 mm UHMW Bearing (1 ea.)	USPB	79206	0.5
6a	1500 mm+ UHMW Bearing (1 ea.)	UHPB	76787	0.5
7	450-1350 mm Stop Collar* (1 ea.)	SCU60	82812	0.9
7a	1500 mm+ Stop Collar* (1 ea.)	SCUHD	82813	0.9
8	450-1350 mm Adjusting Arm* (1 ea.)	HARK	73069	0.9
8a	1500mm+ Adjusting Arm* (1 ea.)	HDARK	77329	0.9
-	450-1350 mm Mounting Kit* (incl. 2 of items 2, 3, 4, 5, 6, 7, 8, 9 & incl. 1 of item 5)	MMKU	77324	18.2
-	1500 mm+ Mounting Kit* (incl. 2 of items 2, 3, 4a, 6, 7a, 8a, 9a & incl 1 of item 5)	MMKUHD	77327	19.6

*Hardware included

Section 9 - Replacement Parts

9.2 Replacement Parts List - Stainless Steel U-Type®

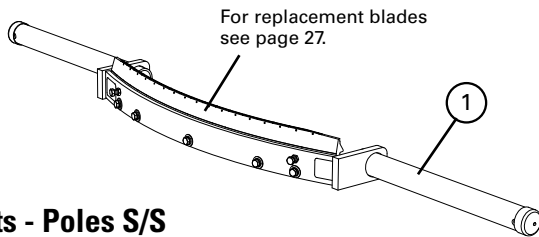

Replacement Parts - Poles S/S

REF	DESCRIPTION	ORDERING NUMBER	ITEM CODE	WT. KG.
1	450mm Pole	USP18/450-S/S	77339	18.6
	600mm Pole	USP24/600-S/S	77340	20.1
	750mm Pole	USP30/750-S/S	77341	21.6
	900mm Pole	USP36/900-S/S	77342	23.2
	1050mm Pole	USP42/1050-S/S	77343	24.8
	1200mm Pole	USP48/1200-S/S	77344	26.3
	1350mm Pole	USP54/1350-S/S	77345	27.9
	1400mm Pole	USP56/1400-S/S	77346	28.4
	1500mm Pole	USP60/1500-S/S	77347	29.5
	1600mm Pole	USP64/1600-S/S	77348	30.5
	1800mm Pole	USP72/1800-S/S	77349	32.6
	2000mm Pole	USP80/2000-S/S	77350	34.6
	2100mm Pole	USP84/2100-S/S	77351	35.7
	2200mm Pole	USP88/2200-S/S	77352	36.7
	2400mm Pole	USP94/2400-S/S	77419	38.3
2500mm Pole	USP98/2500-S/S	77420	39.4	

For shaded items please contact Flexco for lead times.

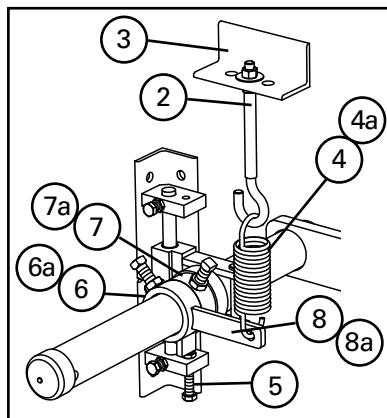

For use in changing UST Spring Tensioner to a J-Bolt Tensioner

Replacement Parts - J-bolt Tensioner S/S

REF	DESCRIPTION	ORDERING NUMBER	ITEM CODE	WT. KG.
2	J-Bolt Kit* (incl. locknut and washer)	STJK-S/S	74417	0.3
3	J-Bolt Mount (1 ea.)	STJM-S/S	77332	1.4
4	450-1350mm Tension Spring (1 ea.)	STTS-S/S	75585	0.5
4a	135500 mm+ Tension Spring (1 ea.)	HDTSS-S/S	75586	0.7
5	Adjusting Bolt Kit (incl. locknut)	ABU	76788	0.5
6	450-1350 mm UHMW Bearing (1 ea.)	USPB	79206	0.5
6a	135500 mm+ UHMW Bearing (1 ea.)	UHPB	76787	0.5
7	450-1350 mm Stop Collar* (1 ea.)	SCU60-S/S	82810	0.9
7a	135500 mm+ Stop Collar* (1 ea.)	SCUHD-S/S	82811	0.9
8	450-1350 mm Adjusting Arm* (1 ea.)	HARK-S/S	77364	0.9
8a	135500mm+ Adjusting Arm* (1 ea.)	HDARK-S/S	77331	0.9
-	450-1350 mm Mounting Kit* (incl. 2 of items 2, 3, 4, 5, 6, 7, 8, 9 & incl. 1 of item 5)	MMKU-SS	77357	18.2
-	135500 mm+ Mounting Kit* (incl. 2 of items 2, 3, 4a, 6, 7a, 8a, 9a & incl 1 of item 5)	MMKUHD-SS	77358	19.6

*Hardware included

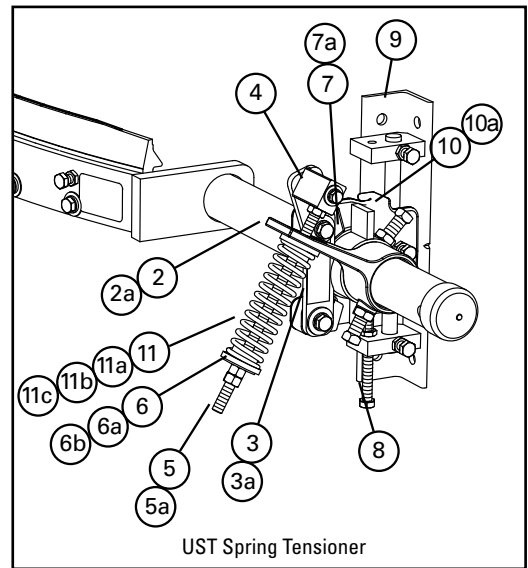

Replacement Parts - UST Tensioner S/S

REF	DESCRIPTION	ORDERING NUMBER	ITEM CODE	WT. KG.
2	Torque Arm Kit (1 ea.)	ESTAK-SS	78849	1.6
2A	Torque Arm Kit HD (1 ea.)	MPSTA-S/S	82289	5.2
3	Pivot Shaft Bracket Kit (1 ea.)	MUPSBK-SS	82893	0.8
3A	Pivot Shaft Bracket Kit HD (1 ea.)	MQMTSBK-SS	82895	2.0
4	Pivot Block Kit (1 ea.)	MESPBL-SS	82892	0.5
5	Pivot Rod Kit (1 ea.)	MESPKR-SS	82894	0.5
5A	Pivot Rod Kit HD (1 ea.)	PTPK-MT-S/S	82342	2.0
6	EST Bush Kit P&S MET	MESBK-PS	82364	0.05
6A	QMT Bush Kit W&S MET	QMTBK-WS-MT	82175	0.05
6B	QMT Bush Kit G MET	QMTBK-GCN	82174	0.05
7	Standard Pole Bearing (1 ea.)	USPB2	79206	0.05
7A	HD Pole Bearing (1 ea.)	UHPB2	79207	0.1
8	Adjusting Bolt Kit (1 ea. incl. lock nut)	ABU	76788	0.1
9	Mounting Bracket Kit (1 ea. incl. L & R)	UMBK-SS-M	82891	4.4
10	Slide Plate Kit (1 ea.)	USPK-SS-M	82888	2.1
10A	HD Slide Plate Kit (1 ea.)	UHSPK-SS-M	82889	2.4
11	Tension Spring Purple (1 ea.)	QMTS-P-SS	77450	0.3
11A	Tension Spring Silver (1 ea.)	ESS-S-S/S	79288	0.5
11B	Tension Spring White (1 ea.)	QMTS-W-SS	77451	0.8
11C	Tension Spring Gold (1 ea.)	QMTS-G-SS	77452	0.8
-	UST Spring Tensioner Mounting Kit* - Purple (Incl. 1 ea. Items 2, 3, 4, 5, 6, 8, 9, 10 & 11)	UST-P-MT-SS	82901	9.5
-	UST Spring Tensioner Mounting Kit* - Silver (Incl. 1 ea. Items 2A, 4, 5A, 6A, 8, 9, 10A & 11A)	UST-S-MT-SS	82902	13.1
-	Heavy-Duty UST Spring Tensioner* - White (Incl. 1 ea. Items 2A, 4, 5A, 6A, 8, 9, 10A & 11B)	UST-W-MT-SS	82903	16.7
-	Heavy-Duty UST Spring Tensioner* - Gold (Incl. 1 ea. Items 2A, 4, 5A, 6A, 8, 9, 10A & 11C)	UST-G-MT-SS	82904	16.7

*Hardware included

Note: For belt widths equal to and larger than 1500mm use heavy-duty components.

Section 9 - Replacement Parts

9.3 Replacement Blades

U-Type® V-Blades (Tungsten Carbide)*

BELT WIDTH mm	ORDERING NUMBER	ITEM CODE	WT. KG.
450	URVB18/450	76736	2.3
600	URVB24/600	76737	3.1
750	URVB30/750	76738	3.8
900	URVB36/900	76739	4.6
1050	URVB42/1050	76740	5.3
1200	URVB48/1200	76741	6.1
1350	URVB54/1350	76742	6.8
1400	URVB56/1400	77314	7.1
1500	URVB60/1500	76743	7.6
1600	URVB64/1600	77315	8.1
1800	URVB72/1800	76744	9.2
2000	URVB80/2000	77320	10.2
2100	URVB84/2100	76745	10.7
2200	URVB88/2200	77316	11.2
2400	URVB94/2400	77421	12.0
2500	URVB98/2500	77422	12.5

*NOTE: V-Blades (Tungsten Carbide) can be used on vulcanised belts. CAUTION: The V-Blade CANNOT be used on belts with mechanical rip repair fasteners. Use the F-Blade. Replacement blades also available in FRAS. Contact Flexco® for more information.

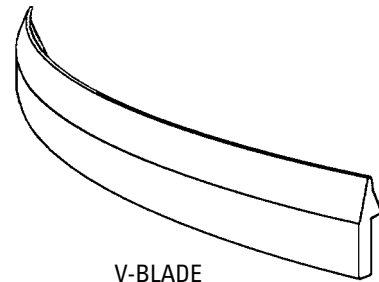

V-BLADE

U-Type® F-Blades (Purple Polyurethane)*

BELT WIDTH mm	ORDERING NUMBER	ITEM CODE	WT. KG.
450	UFB18	74448	1.4
600	UFB24	74449	1.8
750	UFB30	74450	2.3
900	UFB36	74451	2.7
1050	UFB42	74452	3.2
1200	UFB48	74453	3.6
1350	UFB54	74454	4.1
1500	UFB60	74455	4.6
1800	UFB72	74456	5.5
2100	UFB84	74460	6.4

*NOTE: F-Blades (Polyurethane) can be used on mechanically fastened belts and vulcanised belts.

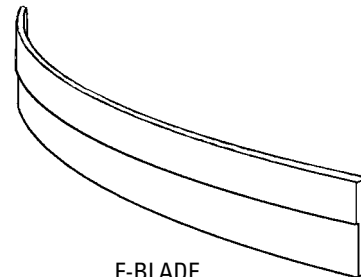

F-BLADE

U-Type® F-Blades FRAS (Blue Polyurethane)*

BELT WIDTH mm	ORDERING NUMBER	ITEM CODE	WT. KG.
450	UFB18-B	67327	1.4
600	UFB24-B	67328	1.8
750	UFB30-B	67329	2.3
900	UFB36-B	67330	2.7
1050	UFB42-B	67331	3.2
1200	UFB48-B	67332	3.6
1350	UFB54-B	67333	4.1
1500	UFB60-B	67334	4.6
1800	UFB72-B	67335	5.5
2100	UFB84-B	67336	6.4

*NOTE: F-Blades (Polyurethane) can be used on mechanically fastened belts and vulcanised belts.

Non-stock items (shaded) please contact Flexco for dispatch options and lead times

Section 10 - Other Flexco Conveyor Products

Flexco provides many conveyor products that help your conveyors to run more efficiently and safely. These components solve typical conveyor problems and improve productivity. Here is a quick overview on just a few of them:

MMP Primary Cleaner



- Extra cleaning power right on the head pulley
- A 250mm (10") TuffShear™ blade provides increased blade tension on the belt to peel off abrasive materials
- The unique Visual Tension Check™ ensures optimal blade tensioning and quick, accurate retensioning
- Easy to install and simple to service

DRX Impact Beds



- Exclusive Velocity Reduction Technology™ to better protect the belt
- Slide-Out Service™ gives direct access to all impact bars for change-out
- Impact bar supports for longer bar life
- 4 models to custom fit to the application

MHS Secondary Cleaner with Service Advantage Cartridge

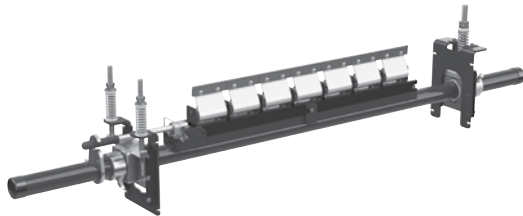

- An easy slide-out cartridge for service
- Cartridge design to speed up blade-change maintenance
- Patented PowerFlex™ Cushions for superior cleaning performance
- Compatible with Flexco mechanical splices

PT Max™ Belt Trainer



- Patented "pivot & tilt" design for superior training action
- Dual sensor rollers on each side to minimise belt damage
- Pivot point guaranteed not to seize or freeze up
- Available for topside and return side belts

Flexco Specialty Belt Cleaners



- "Limited space" cleaners for tight conveyor applications
- High Temp cleaners for severe, high heat applications
- A rubber fingered cleaner for chevron and raised rib belts
- Multiple cleaner styles in stainless steel for corrosive applications

Belt Plows



- A belt cleaner for the tail pulley
- Exclusive blade design quickly spirals debris off the belt
- Economical and easy to service
- Available in vee or diagonal models

236 Albert Amon Rd • Meadowdale Ext. 7 • Germiston 1614 • South Africa
Tel: +27-11-608-4180 • Fax: +27-11-454-5821 • E-mail: flexco@flexco.co.za

Visit www.flexco.com for other Flexco locations and products.

©2019 Flexible Steel Lacing Company. 12/02/20. For reorder: X4675

