

H-TYPE® Precleaner with XF2- or XF-Tips

High Cleaning Efficient Precleaner

The Flexco H-Type® Precleaner with XF2- or XF-Tips is designed to be positioned on the head pulley to remove the bulk of the carryback from the belt. Proven performance over 20 years as the most efficient pre-cleaner in material handling applications such as coal, iron ore, bauxite and hard rock mining.

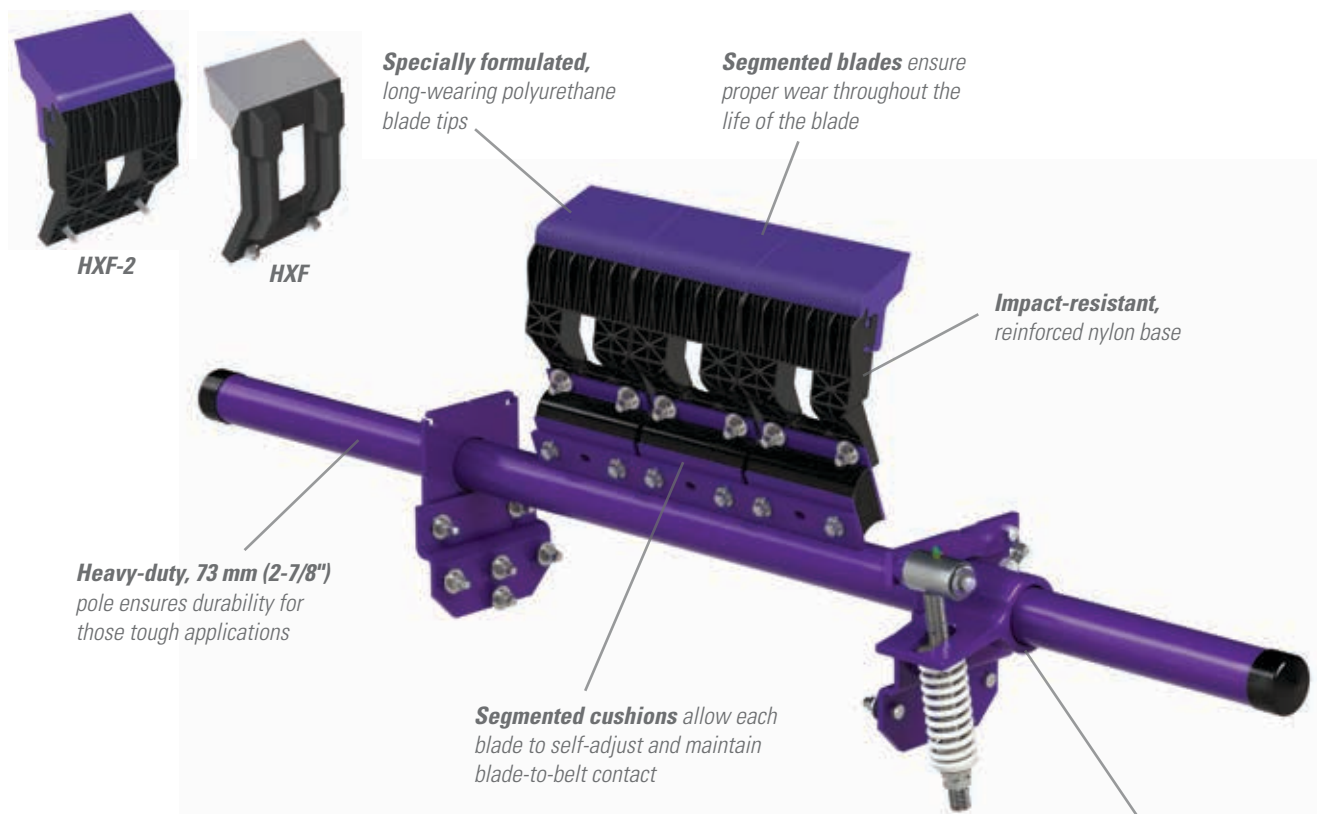

Features and Benefits

- **Works with mechanical fasteners.** The shock-absorbing tensioners and the blade cushion allow mechanical splices, skived or unskived, to pass without damage to the splice or the cleaner and with minimal cleaning disruption.
- **Complete cleaning system.** When teamed with a secondary cleaner, it makes up a system that delivers maximum cleaning power for the most abusive conveyor applications.
- **Made for mining conveyors.** Made from heavy-duty steel with corrosion-resistant powder coating, the H-Type® is available in sizes for belt widths from 450 to 1800mm (18" to 72"). Additional sizes are available upon request.
- **Optimal positioning.** Blade contact on the pulley is 15° below the horizontal centerline. This keeps the blades out of the discharge path and protects them from rocks, large lumps and other debris.



Quick Mount Tensioner (QMT)
allows the blade tension to be visually inspected

H-TYPE® Precleaner XF2- or XF-Tips

Specifications and Guidelines

Maximum Belt Speed

5 m/s 1000 FPM)

Temperature Rating

-35° C to 82° C (-30° F to 180° F)

CEMA Cleaner Rating

Class 4

Minimum Pulley Diameter

250 mm (10")

Usable Blade Wear Length

75 mm (3")

Blade Material

Polyurethane (proprietary blend for abrasion resistance and long wear)

Available for Belt Widths

450 to 1800 mm (18" to 72")

Ordering Information

H-Type® with XF2-Tips				
Belt Width		XF2-Tip Size	Ordering Number	Item Code
mm	in.			
450	18	SS	HXF2-18SS	76138
450	18	S	HXF2-18S	76289
450	18	M	HXF2-18M	76290
600	24	SS	HXF2-24SS	76139
600	24	S	HXF2-24S	76291
600	24	M	HXF2-24M	76292
750	30	SS	HXF2-30SS	76140
750	30	S	HXF2-30S	76293
750	30	M	HXF2-30M	76294
900	36	SS	HXF2-36SS	76141
900	36	S	HXF2-36S	76295
900	36	M	HXF2-36M	76296
900	36	L	HXF2-36L	76297
1050	42	SS	HXF2-42SS	76142
1050	42	S	HXF2-42S	76298
1050	42	M	HXF2-42M	76299
1050	42	L	HXF2-42L	76300
1200	48	SS	HXF2-48SS	76143
1200	48	S	HXF2-48S	76301
1200	48	M	HXF2-48M	76302
1200	48	L	HXF2-48L	76303
1350	54	SS	HXF2-54SS	76144
1350	54	S	HXF2-54S	76304
1350	54	M	HXF2-54M	76305
1350	54	L	HXF2-54L	76306
1500	60	S	HXF2-60S	76145
1500	60	M	HXF2-60M	76307
1500	60	L	HXF2-60L	76308
1800	72	S	HXF2-72S	76146
1800	72	M	HXF2-72M	76309
1800	72	L	HXF2-72L	76310

*NOTE: XF2-Tips must be used on mechanically spliced belts. Can be used on vulcanized belts. XF2-Tip size is determined by head pulley diameter - see chart.

Additional sizes available upon request.

To order a cleaner with XF-Tips, call Customer Service.

Lead time: 1 working day

XF2-Tip & XF-Tip Size		
Head Pulley Diameter + Belt & Lagging		XF2-Tip & XF-Tip Size
mm	in.	
250-475	10 - 19	SS
500-775	20 - 31	S
800-975	32 - 39	M
1000-1175	40 - 47	L

Replacement XF2-Tips		
Size	Ordering Number	Item Code
SS	HXF2-SS	75979
S	HXF2-S	75980
M	HXF2-M	75981
L	HXF2-L	75982

Specially formulated, long-wearing urethane blade tip. Impact-resistant, reinforced nylon base for rigidity and minimal deflection. Lead time: 1 working day

Replacement XF-Tips		
Size	Ordering Number	Item Code
SS	HXF8SS	74307
S	HXF8S	74689
M	HXF8M	74690
L	HXF8L	74691

Lead time: 1 working day

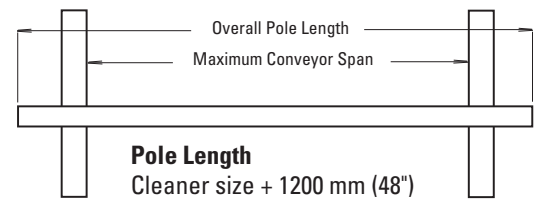

Pole Length

Cleaner size + 1200 mm (48")

Maximum Conveyor Span

Cleaner size + 950 mm (38")

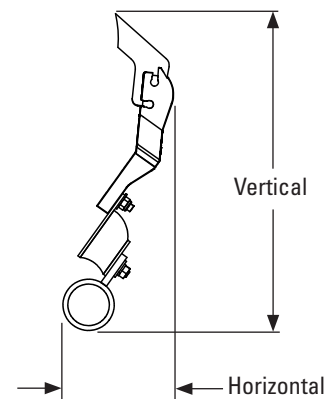
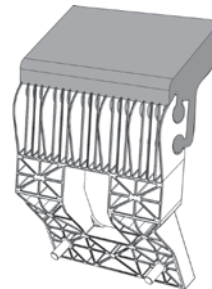

Horizontal Clearance Required

175 mm (7")

Vertical Clearance Required

SS: 325 mm (13")

S: 375 mm (15")

M: 413 mm (16-1/2")

L: 463 mm (18-1/8")

LL: 550 mm (22")

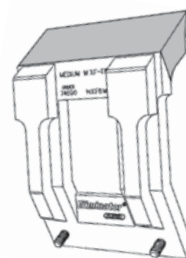

Authorized Distributor:



240 Macpherson Road • #02-01 • Singapore 348574

Tel: +65-6484-1533 • Fax: +65-6484-1531 • E-mail: asiasales@flexco.com

Visit www.flexco.com for other Flexco locations and products.

©2019 Flexible Steel Lacing Company. 07/25/19. For reorder: X4477