

MHS

Heavy-Duty Secondary Belt Cleaner

Superior Cleaning on the Toughest Belts

The MHS Heavy-Duty Secondary Belt Cleaner was designed to deliver and maintain superior cleaning efficiency, even on the most demanding, abusive beltlines. The MHS is the new answer to tough belt cleaning problems. It delivers high-efficiency cleaning, long-lasting performance—and with low maintenance.

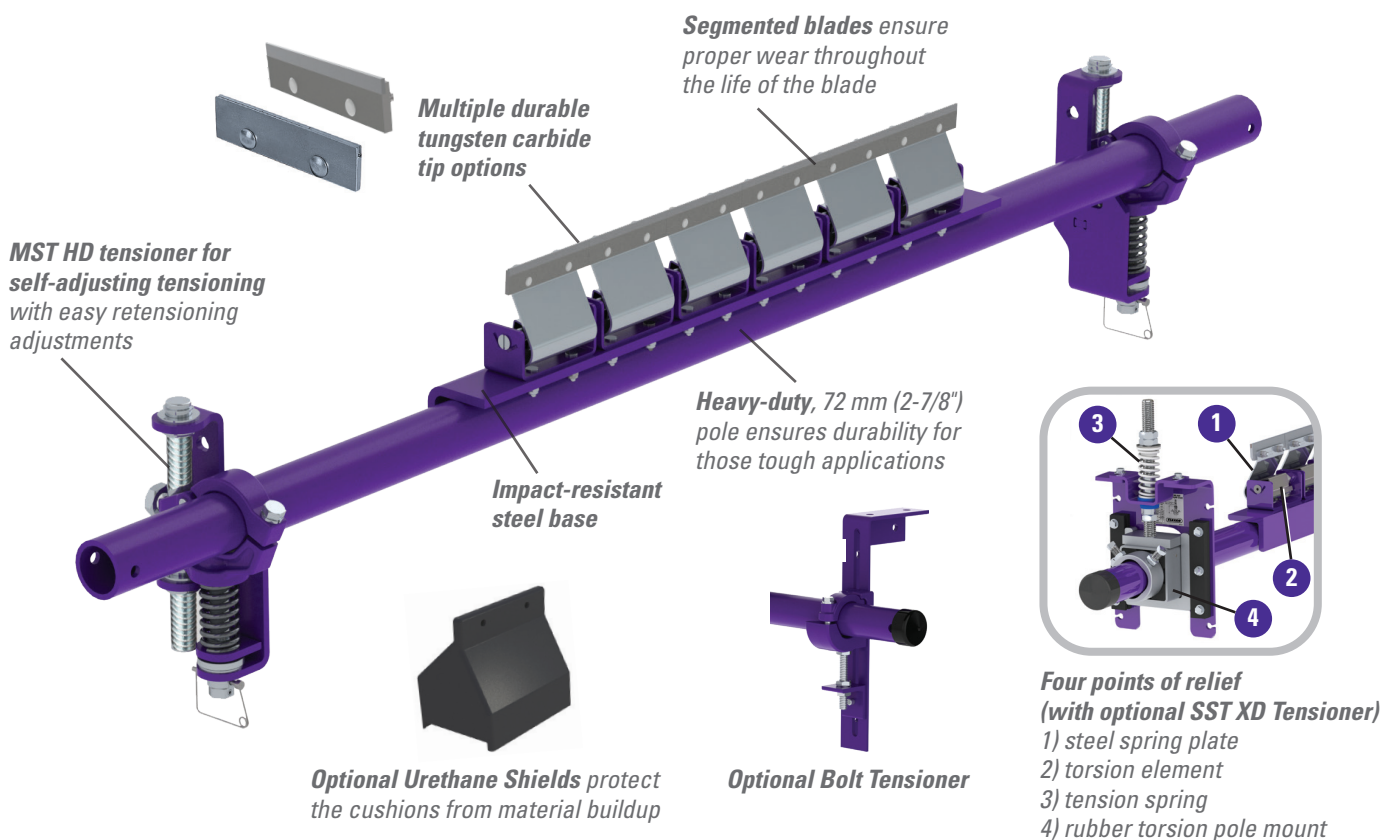

Features and Benefits

- **Cleaning efficiency of metal blades.** The thin, hard edges of the metal blades deliver high cleaning efficiency and long wear life.
- **Works with Flexco mechanical splices.** The C-Tip tungsten carbide blades are impact-resistant, and the spring cushion allows them to move away from a passing splice without damage and with minimal cleaning disruption. V-Tips can be used only on vulcanized belts.
- **A complete cleaning system.** When the MHS is teamed with the MMP precleaner the system provides maximum cleaning power for tough applications.
- **Made for mining conveyors.** Made from heavy-duty, corrosion-resistant steel, the MHS is available in sizes for belt widths from 450 to 2400 mm (18 to 96"). Additional sizes are available upon request.
- **Safe to service.** All service can be performed from a safe position at the side of the conveyor.
- **Also available in stainless steel.**

MHS Heavy-Duty Secondary Belt Cleaner

Specifications and Guidelines

Maximum Belt Speed

5 m/s (1000 FPM) with MST Tensioner
6 m/s (1200 FPM) with SST XD Tensioner

Temperature Rating

-35 to 82°C (-30 to 180°F)

Usable Blade Wear Length

9mm (3/8")

Blade Material

Impact resistant, long-lasting tungsten carbide
(C-Tip for mechanical fasteners, V-Tips for vulcanized belts)

Available for Belt Widths

450 to 1800 mm (18 to 72") with MST Tensioner
450 to 2400 mm (18 to 96") with SST XD Tensioner

CEMA Cleaner Rating

Class 5

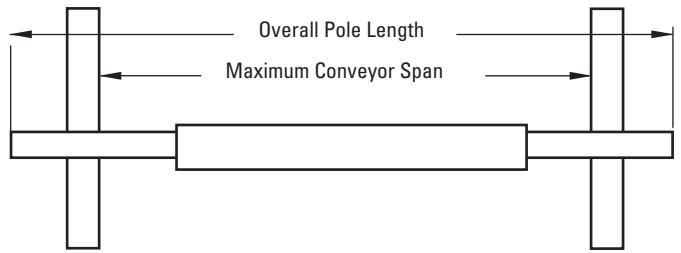

Pole Length Cleaner size +1350 mm (54")

Maximum Conveyor Span Cleaner size + 1100 mm (44")

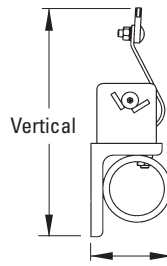

Horizontal Clearance Required
100 mm (4")

Vertical Clearance Required
245 mm (10")

Ordering Information

MHS HD with MST*			
Belt Width		Ordering Number	Item Code
mm	in.		
600	24	MHS-600-MST	64020
750	30	MHS-750-MST	64021
900	36	MHS-900-MST	64022
1050	42	MHS-1050-MST	64023
1200	48	MHS-1200-MST	64024
1350	54	MHS-1350-MST	64025
1500	60	MHS-1500-MST	64026
1800	72	MHS-1800-MST	64027
2100	84	MHS-2100-MST	64028
2400	96	MHS-2400-MST	64029

*Contact Flexco for stainless steel options

MHS HD with MST and V-Tips*			
Belt Width		Ordering Number	Item Code
mm	in.		
450	18	MHS-18V-MST	79442
600	24	MHS-24V-MST	79443
750	30	MHS-30V-MST	79444
900	36	MHS-36V-MST	79445
1050	42	MHS-42V-MST	79446
1200	48	MHS-48V-MST	79447
1350	54	MHS-54V-MST	79448
1500	60	MHS-60V-MST	79449
1800	72	MHS-72V-MST	79450

*V-Tips can be used ONLY on vulcanized belts

MHS HD Reversing with MST and V-Tips*			
Belt Width		Ordering Number	Item Code
mm	in.		
450	18	MHS-18RMV	79624
600	24	MHS-24RMV	79625
750	30	MHS-30RMV	79626
900	36	MHS-36RMV	79627
1050	42	MHS-42RMV	79628
1200	48	MHS-48RMV	79629
1350	54	MHS-54RMV	79630
1500	60	MHS-60RMV	79631
1800	72	MHS-72RMV	79632

*V-Tips can be used ONLY on vulcanized belts

Replacement Tips	
Ordering Number	Item Code
ICT6	74535
RSA150	73628

Urethane Shields	
Ordering Number	Item Code
UPFCC	79320

MHS HD with Bolt Tensioner*			
Belt Width		Ordering Number	Item Code
mm	in.		
600	24	MHS-600BTV	77481
750	30	MHS-750BTV	77482
900	36	MHS-900BTV	77483
1050	42	MHS-1050BTV	77484
1200	48	MHS-1200BTV	77525
1350	54	MHS-1350BTV	77485
1500	60	MHS-1500BTV	77486
1800	72	MHS-1800BTV	77487
2100	84	MHS-2100BTV	77488
2400	96	MHS-2400BTV	77489

*Contact Flexco for stainless steel options

MHS HD with SST XD and V-Tips*			
Belt Width		Ordering Number	Item Code
mm	in.		
600	24	MHS-600FPV	77789
750	30	MHS-750FPV	77790
900	36	MHS-900FPV	77791
1050	42	MHS-1050FPV	77792
1200	48	MHS-1200FPV	77793
1350	54	MHS-1350FPV	77794
1500	60	MHS-1500FPV	77795
1800	72	MHS-1800FPV	77796
2100	84	MHS-2100FPV	77797
2400	96	MHS-2400FPV	77798

*Contact Flexco for Stainless Steel Options

MHS HD Reversing with SST XD and V-Tips*			
Belt Width		Ordering Number	Item Code
mm	in.		
450	18	MHS-18RV	76646
600	24	MHS-24RV	76647
750	30	MHS-30RV	76648
900	36	MHS-36RV	76649
1050	42	MHS-42RV	76650
1200	48	MHS-48RV	76651
1350	54	MHS-54RV	76652
1500	60	MHS-60RV	76653
1800	72	MHS-72RV	76654
2100	84	MHS-84RV	76805
2400	96	MHS-96RV	79046

*V-Tips can be used ONLY on vulcanized belts

Tips Required Per Cleaner Size											
mm	450	600	750	900	1050	1200	1350	1500	1800	2100	2400
in.	18	24	30	36	42	48	54	60	72	84	96
C-Tips or V-Tips Required	3	4	5	6	7	8	9	10	12	14	16

Visit www.flexco.com for other Flexco locations and products, or to find an authorised distributor.

©2021 Flexible Steel Lacing Company. 01-30-24. X4107

