

V-Plow

Installation, Operation and Maintenance Manual



V-Plow

Serial Number: _____

Purchase Date: _____

Purchased From: _____

Installation Date: _____

Serial number information can be found on the Serial Number Label included in the Information Packet found in the cleaner carton.

This information will be helpful for any future inquiries or questions about belt cleaner replacement parts, specifications or troubleshooting.

Table of Contents

Section 1 - Important Information	4
1.1 General Introduction	4
1.2 User Benefits	4
1.3 Service Option	4
Section 2 - Safety Considerations and Precautions	5
2.1 Stationary Conveyors	5
2.2 Operating Conveyors	5
Section 3 - Pre-Installation Checks and Options	6
3.1 Checklist	6
Section 4 - Installation Instructions	7
Section 5 - Pre-Operation Checklist and Testing	9
5.1 Pre-Op Checklist	9
5.2 Test Run the Conveyor	9
Section 6 - Maintenance	10
6.1 New Installation Inspection	10
6.2 Routine Visual Inspection	10
6.3 Routine Physical Inspection	10
6.4 Blade Replacement Instructions	11
6.5 Maintenance Log	12
6.6 Cleaner Maintenance Checklist	13
Section 7 - Troubleshooting	14
Section 8 - Specs and CAD Drawings	15
8.1 Specs and Guidelines	15
8.2 CAD Drawings	16
Section 9 - Replacement Parts	17
9.1 Replacement Parts List	17
Section 10 - Other Flexco Conveyor Products	19

Section 1 - Important Information

1.1 General Introduction

We at Flexco are very pleased that you have selected the V-Plow for your conveyor system.

This manual will help you to understand the operation of this product and assist you in making it work up to its maximum efficiency over its lifetime of service.

It is essential for safe and efficient operation that the information and guidelines presented be properly understood and implemented. This manual will provide safety precautions, installation instructions, maintenance procedures and troubleshooting tips.

If, however, you have any questions or problems that are not covered, please visit our web site or contact our Customer Service Department:

Customer Service: 91-44-6551-7771

Visit www.flexco.com for other Flexco locations and products.

Please read this manual thoroughly and pass it on to any others who will be directly responsible for installation, operation and maintenance of this cleaner. While we have tried to make the installation and service tasks as easy and simple as possible, it does however require correct installation and regular inspections and adjustments to maintain top working condition.

1.2 User Benefits

Correct installation and regular maintenance will provide the following benefits for your operation:

- Reduced conveyor downtime
- Reduced man-hour labor
- Lower maintenance budget costs
- Increased service life for the plow and other conveyor components

1.3 Service Option

The V-Plow is designed to be easily installed and serviced by your on-site personnel. However, if you would prefer complete turn-key factory service, please contact your local Flexco Field Engineer or your Flexco Distributor.

Section 2 - Safety Considerations and Precautions

Before installing and operating the V-Plow, it is important to review and understand the following safety information.

There are set-up, maintenance and operational activities involving both stationary and operating conveyors. Each case has a safety protocol.

2.1 Stationary Conveyors

The following activities are performed on stationary conveyors:

- Installation
- Blade replacement
- Repairs
- Tension adjustments
- Cleaning

DANGER

It is imperative that OSHA/MSHA Lockout/Tagout (LOTO) regulations, 29 CFR 1910.147, be followed before undertaking the preceding activities. Failure to use LOTO exposes workers to uncontrolled behavior of the plow caused by movement of the conveyor belt. Severe injury or death can result.

Before working:

- Lockout/Tagout the conveyor power source
- Disengage any takeups
- Clear the conveyor belt or clamp securely in place

WARNING

Use Personal Protective Equipment (PPE):

- Safety eyewear
- Hardhats
- Safety footwear

Close quarters, springs and heavy components create a worksite that compromises a worker's eyes, feet and skull.

PPE must be worn to control the foreseeable hazards associated with the plows. Serious injuries can be avoided.

2.2 Operating Conveyors

There are two routine tasks that must be performed while the conveyor is running:

- Inspection of the cleaning performance
- Dynamic troubleshooting

DANGER

Every plow is an in-running nip hazard. Never touch or prod an operating plow. Plow hazards cause instantaneous amputation and entrapment.

WARNING

Plows can become projectile hazards. Stay as far from the plow as practical and use safety eyewear and headgear. Missiles can inflict serious injury.

WARNING

Never adjust anything on an operating plow. Unforseeable belt projections and tears can catch on plows and cause violent movements of the plow structure. Flailing hardware can cause serious injury or death.

Section 3 - Pre-installation Checks and Options

3.1 Checklist

- Check that the plow size is correct for the beltline width
- Check the product carton and make sure all the parts are included
- Review the “Tools Needed” list on the top of the installation instructions
- Check the conveyor site:
 - Are there obstructions that may require plow location adjustments
 - Ensure proper clearance is available between top side and return side belts (10”/ 250mm)

Section 4 - Installation Instructions - V-Plow

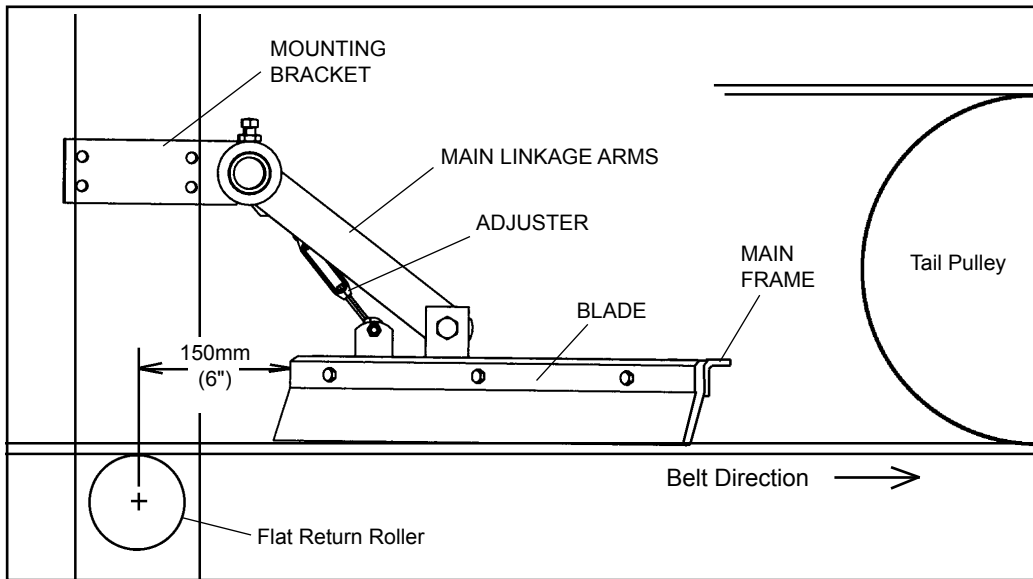

Physically lock out and tag the conveyor at the power source before you begin installation.

Before Installation: Ideally the V-Plow should be positioned in a flat area on the inside of the belt close to the tail pulley. For optimum cleaning performance, the nose of the plow should be located about 6" (150mm) behind a return roller.

Tools Needed:

- 14mm (9/16") wrench
- 13mm (1/2") wrench
- 19mm (3/4") wrench
- 124mm (5/16") wrench

STEP 1. Measure the distance between the top side and return belts. A minimum of 250mm (10") is required (Fig. 1). Place the V-Plow on the belt, positioned as specified above, to check for any clearance or obstruction problems.

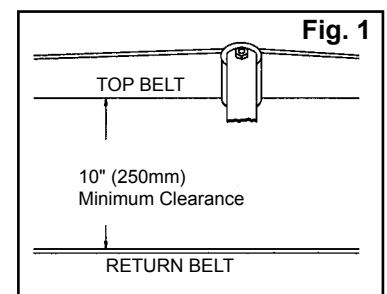

STEP 2. Position the mounting brackets in either a horizontal or vertical position.

The centerline of the pole must be within a range of 200mm to 350mm (8" to 14") above the return belt to insure proper performance (Fig. 2a). **IMPORTANT:** The main linkage arms must be operated in a range between a minimum of 10° and a maximum of 45° (Fig. 2b). This allows the V-Plow to float on the belt.

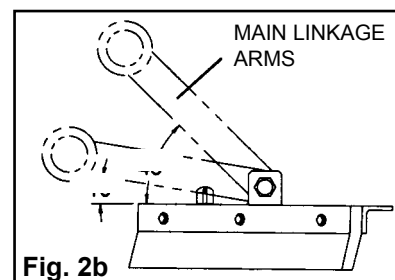
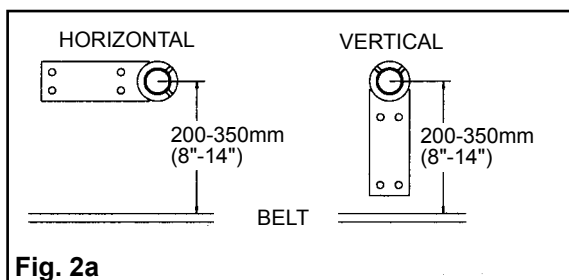

Section 4 – Installation Instructions (cont.)

Fig. 3

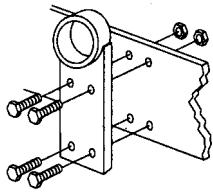

STEP 3. Mark and drill holes for the mounting brackets.

Attach with 13mm" (1/2) bolts and nuts provided (Fig. 3). Welding is optional.

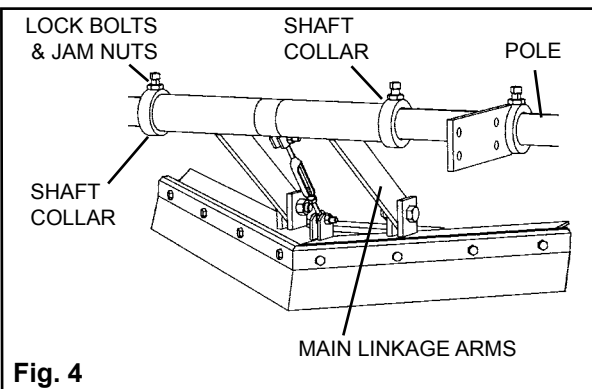

Fig. 4

STEP 4. Center the V-Plow on the belt.

Loosen the jam nuts and lock bolts on both stop collars on the pole. Slide the plow in the direction needed to center it on the belt. Once located, slide stop collars up to main linkage arms and tighten the lock bolts and jam nuts (Fig. 4). NOTE: Do not push stop collars too tightly against the main linkage assemblies so that it restricts easy movement of the linkage.

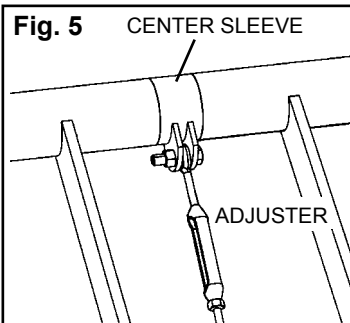

Fig. 5

STEP 5. Attach the adjuster to the center sleeve.

Remove the nut and bolt from the center sleeve, insert the end of the adjuster between the brackets, and reinstall the nut and bolt (Fig. 5).

IMPORTANT: Tighten only until snug; the adjuster should move freely.

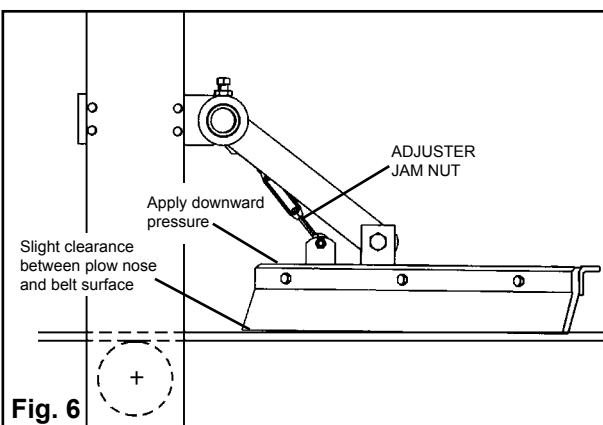

Fig. 6

STEP 6. Position the V-Plow to the belt.

While applying downward pressure to the nose of the plow, turn the adjuster so that the nose just begins to lift off the surface of the belt (about .25 mm/.010"). Tighten the adjuster jam nut (Fig. 6).

STEP 7. Test run and inspect.

Run the belt and check that the V-Plow runs smoothly and has an effective cleaning action. If any vibration occurs, turn the adjuster to raise the nose slightly.

Section 5 - Pre-Operation Checklist and Testing

5.1 Pre-Op Checklist

5.1 Pre-Op Checklist

- Recheck that all fasteners are tightened properly
- Check the blade location on the belt
- Be sure that all installation materials and tools have been removed from the belt and the conveyor area

5.2 Test Run the Conveyor

- Run the conveyor for at least 15 minutes and inspect the performance
- Make adjustments as necessary

NOTE: Observing the plow when it is running and performing properly will help to detect problems or when adjustments are needed later.

Section 6 - Maintenance

Flexco belt plows are designed to operate with minimum maintenance. However, to maintain superior performance some service is required. When the plow is installed a regular maintenance program should be set up. This program will ensure that the plow operates at optimal efficiency and problems can be identified and fixed before the plow stops working.

All safety procedures for inspection of equipment (stationary or operating) must be observed. The V-Plow operates near the tail pulley and is in direct contact with the moving belt. Only visual observations can be made while the belt is running. Service tasks can be done only with the conveyor stopped and by observing the correct lockout/tagout procedures.

6.1 New Installation Inspection

After the new plow has run for a few days a visual inspection should be made to ensure the cleaner is performing properly. Make adjustments as needed.

6.2 Routine Visual Inspection (every 2-4 weeks)

A visual inspection of the plow and belt can determine:

- If the blade has optimal tensioning
- If the belt looks clean or if there are areas that are dirty
- If the blade is worn out and needs to be replaced
- If there is damage to the blade or other belt plow components
- If fugitive material is built up on the plow or in the transfer area
- If there is cover damage to the belt
- If there is vibration or bouncing of the plow on the belt
- Check for build up on the leading return roll

If any of the above conditions exist, a determination should be made on when the conveyor can be stopped for cleaner maintenance.

6.3 Routine Physical Inspection (every 6-8 weeks)

When the conveyor is not in operation and properly locked and tagged out a physical inspection of the belt plow to perform the following tasks:

- Clean material buildup off of the belt plow blade and frame
- Closely inspect the blade for wear and any damage. Replace if needed.
- Ensure full blade to belt frame contact (tip should have slight clearance)
- Inspect the belt plow pole for damage
- Inspect all fasteners for tightness and wear. Tighten or replace as needed.
- Replace any worn or damaged components
- When maintenance tasks are completed, test run the conveyor to ensure the belt plow is performing properly

Section 6 - Maintenance (cont.)

6.4 Blade Replacement Instructions

PHYSICALLY LOCK OUT AND TAG THE CONVEYOR AT THE POWER SOURCE BEFORE YOU BEGIN MAINTENANCE.

Tools Needed:

- 14mm (9/16") wrench
- 13mm (1/2") wrench
- 19mm (3/4") wrench
- 24mm (15/16") wrench

- 1. Loosen adjuster jam nut.** After adjuster jam nut is loose the adjuster can be turned to provide more clearance for the new blade (Fig 1.)

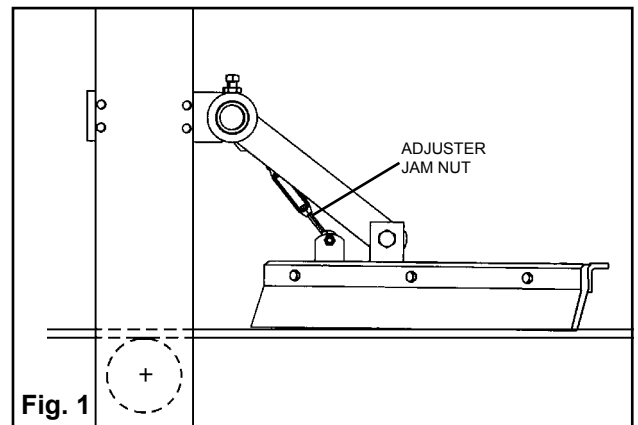

- 2. Remove worn blade.** Unscrew all bolts securing the worn blade to plow main frame. Remove the blade and clean off any remaining material on plow frame (Fig 2.)

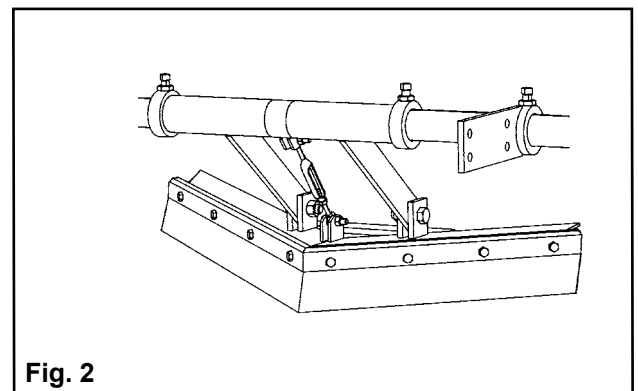

- 3. Install new blade.** Use current bolts to secure new blade to main frame.

- 4. Position the V-Plow to the belt.** While applying downward pressure to the nose of the plow, turn the adjuster so that the nose just begins to lift off the surface of the belt (about .25 mm/.010"). Tighten the adjuster jam nut (Fig. 3).

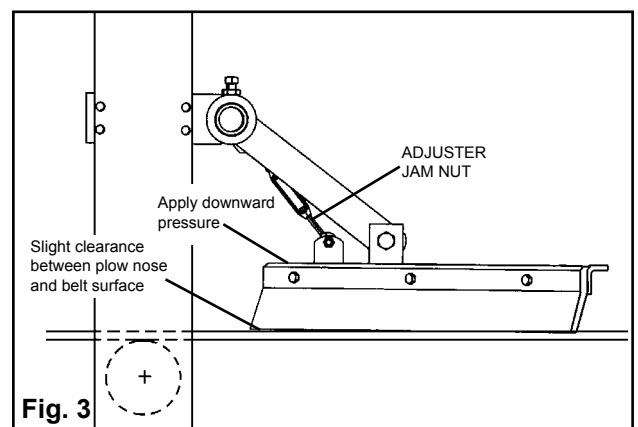

- 5. Test run and inspect.** Run the belt and check that the V-Plow runs smoothly and has an effective cleaning action. If any vibration occurs, turn the adjuster to raise the nose slightly.

Section 6 - Maintenance (cont.)

6.5 Maintenance Log

Conveyor Name/No. _____

Date: _____ Work done by: _____ Service Quote # _____

Activity: _____

Date: _____ Work done by: _____ Service Quote # _____

Activity: _____

Date: _____ Work done by: _____ Service Quote # _____

Activity: _____

Date: _____ Work done by: _____ Service Quote # _____

Activity: _____

Date: _____ Work done by: _____ Service Quote # _____

Activity: _____

Date: _____ Work done by: _____ Service Quote # _____

Activity: _____

Date: _____ Work done by: _____ Service Quote # _____

Activity: _____

Section 6 - Maintenance (cont.)

6.6 Plow Maintenance Checklist

Plow: _____ Serial Number: _____

Beltline Information:

Beltline Number: _____ Belt Condition: _____

Belt Width: 18" 24" 30" 36" 42" 48" 54" 60" 72" 84" 96"
(450mm) (600mm) (750mm) (900mm) (1050mm) (1200mm) (1350mm) (1500mm) (1800mm) (2100mm) (2400mm)

Head Pulley Diameter (Belt & Lagging): _____ Belt Speed: _____ fpm Belt Thickness: _____

Belt Splice _____ Condition of Splice _____ Number of splices _____ Skived Unskived

Material conveyed _____

Days per week run _____ Hours per day run _____

Blade Life:

Date blade installed: _____ Date blade inspected: _____ Estimated blade life: _____

Is blade making complete contact with belt? Yes No

Distance from wear line: LEFT _____ MIDDLE _____ RIGHT _____

Blade condition: Good Grooved Smiled Not contacting belt Damaged

Was Plow Adjusted: Yes No

Frame Condition: Good Bent Worn

Lagging: Slide lag Ceramic Rubber Other None

Condition of lagging: Good Bad Other _____

Plow's Overall Performance:

(Rate the following 1 - 5, 1=very poor - 5= very good)

Appearance: Comments: _____

Location: Comments: _____

Maintenance: Comments: _____

Performance: Comments: _____

Other Comments: _____

Section 7 - Troubleshooting

Problem	Possible Cause	Possible Solutions
Poor cleaning performance	Plow not making proper contact with belt	1. Check location of plow to flat return roller
		2. Check turnbuckle adjustment and check main linkage arm angles
Attaining proper float	Restriction in movement on linkage arms	Shaft/ stop collars may be too tight
Material getting through	Too much space between belt and blade	Check V-Plow nose for proper clearance between nose and belt. Check adjuster arm angles.
	Mechanical splice damaging blade	Repair, skive, or replace splice

Section 8 - Specs and CAD Drawings

8.1 Specs and Guidelines

V-Plow

Belt Width Specifications

SIZE	BELT WIDTH (Min-Max)	
	mm	in.
Extra Small	450-600	18-24
Small	750-900	30-36
Medium	1050-1200	42-48
Large	1350-1500	54-60
72"	1800	72
84"	2100	84
96"	2400	96

Use next larger size for belt widths between ranges.

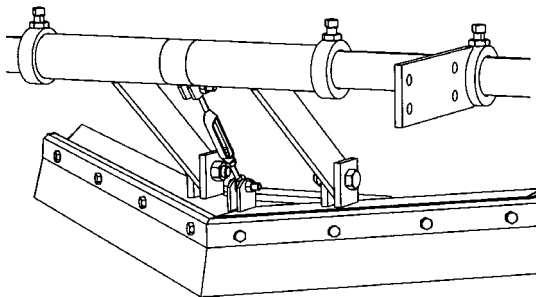

V-Plow

Blade Specifications

Material	UHMWPE
Durometer	67-D
Working Temperature	
°C	-40° to 71°
°F	-40° to 160°
Grease & Chemical Resistance	Excellent
Sticky Material Performance	Excellent

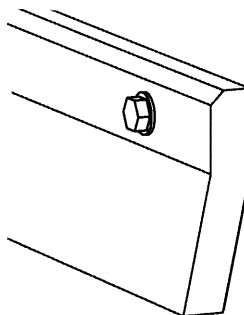

Application Guidelines

- Belt Splice..... Mechanically Fastened/Vulcanized
- Belt Speed..... 1000 FPM (5M/sec) for V-Plow
- Belt Direction..... One Way

Section 8 - Specs and CAD Drawings

8.2 CAD Drawings

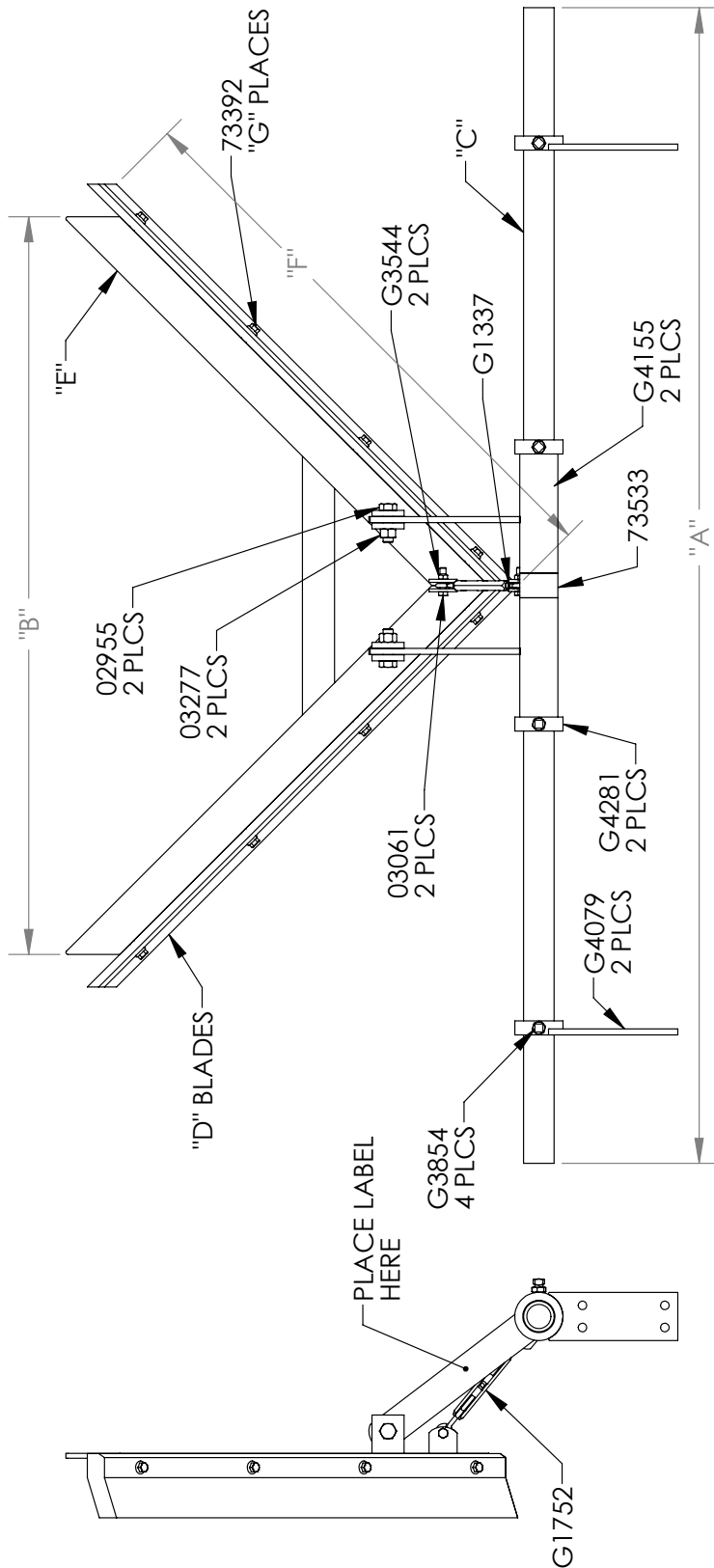

PART NUMBER	BELT WIDTH	"A"	"B"	"C"	"D"	"E"	"F"	"G"
73131	18-24 (457-610)	48 (1219)	22 3/4 (578)	73400	73182 73183	73535	18.38 (467)	4
73132	30-36 (762-914)	60 (1524)	33 1/2 (850)	73408	73184 73185	73549	26.87 (683)	6
73133	42-48 (1067-1219)	72 (1829)	46 (1168)	73409	73186 73187	74037	35.36 (898)	8
73134	54-60 (1372-1524)	85 (2159)	59 1/2 (1511)	73410	73188 73189	74038	43.85 (1114)	10
74389	72 (1800)	97 (2464)	76 (1930)	74395	74442 74443	74398	53.74 (1365)	12
74390	84 (2100)	109 (2769)	88 (2235)	74396	74444 74445	74399	62.23 (1581)	14
74391	96 (2400)	121 (3073)	100 (2540)	74397	74446 74447	74440	70.71 (1796)	16

Section 9 - Replacement Parts

9.1 Replacement Parts List

Replacement Parts - V-Plow

REF	DESCRIPTION	BELT WIDTH (Min-Max)		ORDERING NUMBER	ITEM CODE	WT. LBS.
		mm	in.			
1	V-Plow Pole XS	450-600	18-24	VPXS	73400	13.0
	V-Plow Pole S	750-900	30-36	VPS	73408	15.0
	V-Plow Pole M	1050-1200	42-48	VPM	73409	18.0
	V-Plow Pole L	1350-1500	54-60	VPL	73410	21.0
	V-Plow Pole 72	1800	72	VP72	74395	24.0
	V-Plow Pole 84	2100	84	VP84	74396	27.0
	V-Plow Pole 96	2400	96	VP96	74397	30.0
2	V-Plow Mainframe XS	450-600	18-24	VMFXS	73535	12.0
	V-Plow Mainframe S	750-900	30-36	VMFS	73549	15.0
	V-Plow Mainframe M	1050-1200	42-48	VMFM	74037	22.0
	V-Plow Mainframe L	1350-1500	54-60	VMFL	74038	28.0
	V-Plow Mainframe 72	1800	72	VMF72	74398	35.0
	V-Plow Mainframe 84	2100	84	VMF84	74399	42.0
	V-Plow Mainframe 96	2400	96	VMF96	74440	50.0
3	VP Main Linkage Kit* (1 ea.)			VMLK	74982	5.0
4	VP Center Sleeve			VCS	73533	1.0
5	V-Plow Adjuster Kit*			VAK	76416	0.5
6	VP Stop Collar* (1 ea.)			VSC	74983	1.0
7	VP Mounting Bracket Kit* (1 ea.)			VMBK	73399	5.0
REPLACEMENT BLADE KITS**						
8	Replacement Blade Kit XS	450-600	18-24	VBK-XS	73190	4.5
	Replacement Blade Kit S	750-900	30-36	VBK-S	73191	6.0
	Replacement Blade Kit M	1050-1200	42-48	VBK-M	73192	7.5
	Replacement Blade Kit L	1350-1500	54-60	VBK-L	73193	9.0
	Replacement Blade Kit 72	1800	72	VBK-72	74457	13.0
	Replacement Blade Kit 84	2100	84	VBK-84	74458	15.0
	Replacement Blade Kit 96	2400	96	VBK-96	74459	17.0

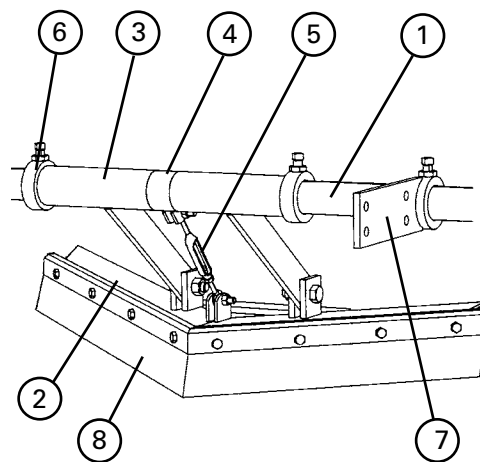

Shaded items are made to order.
Lead time: 10 working days

*Hardware included

**Kit includes blades and replacement blade bolts.

Lead time: 1 working day

Section 10 - Other Flexco Conveyor Products

Flexco provides many conveyor products that help your conveyors to run more efficiently and safely. These components solve typical conveyor problems and improve productivity. Here is a quick overview on just a few of them:

EZP1 Precleaner



- Patented ConShear™ blade renews its cleaning edge as it wears
- Visual Tension Check™ for optimal blade tensioning and simple retensioning
- Quick and easy one-pin blade replacement
- Material Path Option™ for optimal cleaning and reduced maintenance

DRX Impact Beds



- Exclusive Velocity Reduction Technology™ to better protect the belt
- Slide-Out Service™ gives direct access to all impact bars for change-out
- Impact bar supports for longer bar life
- 4 models to custom fit to the application

EZS2 Secondary Cleaner



- Long-wearing tungsten carbide blades for superior cleaning efficiency
- Patented FormFlex™ cushions independently tension each blade to the belt for consistent, constant cleaning power
- Easy to install, simple to service
- Works with Flexco mechanical belt splices

PT Max™ Belt Trainer



- Patented “pivot & tilt” design for superior training action
- Dual sensor rollers on each side to minimize belt damage
- Pivot point guaranteed not to freeze up
- Available for topside and return side belts

Flexco Specialty Belt Cleaners



- “Limited space” cleaners for tight conveyor applications
- High Temp cleaners for severe, high heat applications
- A rubber fingered cleaner for chevron and raised rib belts
- Multiple cleaner styles in stainless steel for corrosive applications

The Flexco Vision

To become the leader in maximising
belt conveyor productivity for our customers worldwide
through superior service and innovation.

New Door No. 51 • Anna Salai, Nagalkeni • Pammal Village • Chennai - 600 044 • Tamil Nadu • India
Tel: +91-44-4856-6762 • E-mail: info.india@flexco.com

Visit www.flexco.com for other Flexco locations and products.

©2015 Flexible Steel Lacing Company. 02-21-19. For reorder: X4019

