

Reliable Cleaning at an Affordable Price

The FMS Secondary Belt Cleaner features carbide blades, self-adjusting spring tensioners and unique cushions that independently tension each blade to the belt. This simple but durable design provides quality cleaning performance at an affordable price.

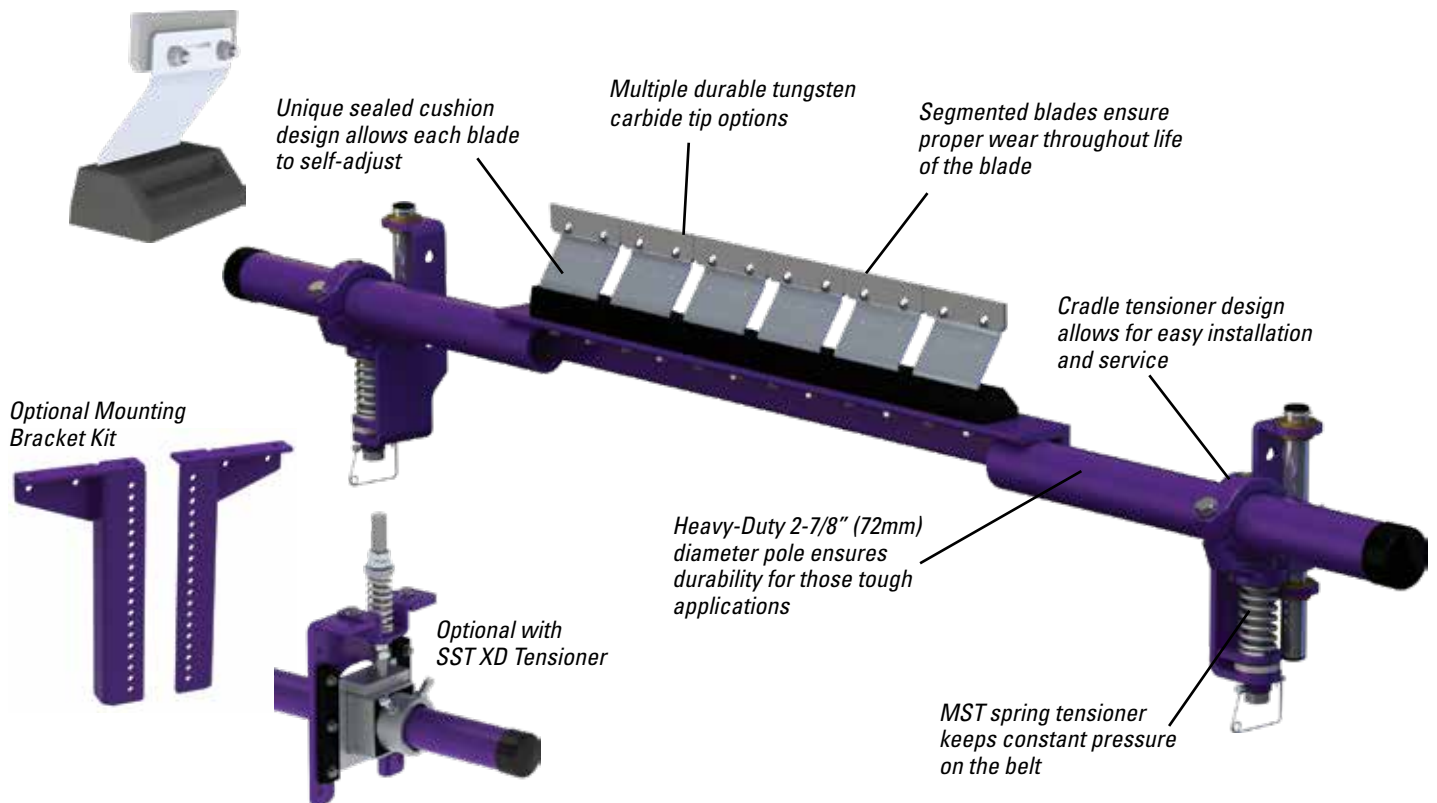

Features and Benefits

- **Made for mining conveyors.** Made from heavy-duty steel with corrosion-resistant powder coating, the FMS is available in sizes for belt widths from 18" to 72" (450 to 1800mm). Additional sizes are available upon request.
- **For belt speeds up to 1000 fpm (5M/s).**
- **Compact spring tensioner.** Utilizes the MST tensioner to maintain constant pressure on the belt.
- **Cleaning efficiency of metal blades.** The thin, hard edges of the 6" (150mm) wide metal blades deliver high cleaning efficiency and long wear life.
- **Works with Flexco mechanical splices.** The C-Tip tungsten carbide blades are impact-resistant, and the spring cushion allows them to move away from a passing splice without damage and with minimal cleaning disruption. V-Tips can be used only on vulcanized belts.
- **A complete cleaning system.** When the FMS is teamed with the MSP or MMP Precleaner the system provides excellent cleaning power for tough applications.

FMS Secondary Cleaner

Specifications and Guidelines

Maximum Belt Speed

1000 FPM (5 m/s)

Temperature Rating

-30F to 300F (-35C to 148C)

Usable Blade Wear Length

3/8" (9 mm)

Available for Belt Widths

18" to 72" (450 to 1800 mm)

Blade Material

Impact resistant, long-lasting tungsten carbide (C-Tips for mechanical fasteners, V-Tips for vulcanized belts)

CEMA Cleaner Rating

Class 4

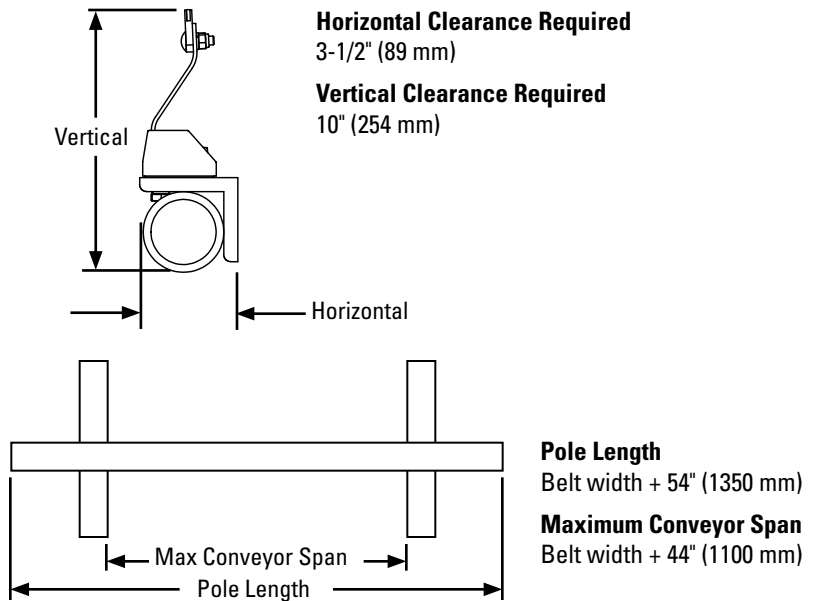

Ordering Information

FMS with MST Secondary with C-Tips

Belt Width		Complete Cleaner	
in.	mm	Ordering Number	Item Code
18	450	FMS-18	79637
24	600	FMS-24	79638
30	750	FMS-30	79639
36	900	FMS-36	79640
42	1050	FMS-42	79641
48	1200	FMS-48	79642
54	1350	FMS-54	79643
60	1500	FMS-60	79644
72	1800	FMS-72	79645

Lead time: 1 working day

FMS with MST Secondary with V-Tips

Belt Width		Complete Cleaner	
in.	mm	Ordering Number	Item Code
18	450	FMS-18V	79646
24	600	FMS-24V	79647
30	750	FMS-30V	79648
36	900	FMS-36V	79649
42	1050	FMS-42V	79650
48	1200	FMS-48V	79651
54	1350	FMS-54V	79652
60	1500	FMS-60V	79653
72	1800	FMS-72V	79654

Lead time: 1 working day

FMS with SST XD Secondary with C-Tips

Belt Width		Complete Cleaner	
in.	mm	Ordering Number	Item Code
18	450	FMS-18-SSTXD	92185
24	600	FMS-24-SSTXD	92186
30	750	FMS-30-SSTXD	92187
36	900	FMS-36-SSTXD	92188
42	1050	FMS-42-SSTXD	92189
48	1200	FMS-48-SSTXD	92190
54	1350	FMS-54-SSTXD	92191
60	1500	FMS-60-SSTXD	92192
72	1800	FMS-72-SSTXD	92193

Lead time: 1 working day

FMS with SST XD Secondary with V-Tips

Belt Width		Complete Cleaner	
in.	mm	Ordering Number	Item Code
18	450	FMS-18V-SSTXD	92194
24	600	FMS-24V-SSTXD	92195
30	750	FMS-30V-SSTXD	92196
36	900	FMS-36V-SSTXD	92197
42	1050	FMS-42V-SSTXD	92198
48	1200	FMS-48V-SSTXD	92199
54	1350	FMS-54V-SSTXD	92200
60	1500	FMS-60V-SSTXD	92201
72	1800	FMS-72V-SSTXD	92202

Lead time: 1 working day

Replacement Tips

Ordering Number	Item Code
ICT6 (C-Tip)	74535
RSA150 (V-Tip)	73628

Replacement Cushion

Ordering Number	Item Code
FMSC	79699

Drop Bracket Kit

Ordering Number	Item Code
MSTDDB	79434
SSTSMB	76071
SSTLMB	76072

Blades Required per Cleaner Size

in.	18	24	30	36	42	48	54	60	72
mm	450	600	750	900	1050	1200	1350	1500	1800
Blades Required	3	4	5	6	7	8	9	10	12



Authorized Distributor:



2525 Wisconsin Avenue • Downers Grove, IL 60515-4200 • USA
Tel: (630) 971-0150 • Fax: (630) 971-1180 • E-mail: info@flexco.com

Visit www.flexco.com for other Flexco locations and products.

©2022 Flexible Steel Lacing Company, 12/01/22. For reorder: X3865

