

# Hitch Guard - with Universal Mounting Bracket Installation Instructions

## Parts Included in Hitch Guard Kit:

- Hitch Guard Support Bar (1)
- Center Segments
- Right End Segment (1)
- Left End Segment (1)
- Mounting Plates (2)
- 1/4-20×1.5" Cap Screws (6)
- 1/4-20 Hex Nuts (6)
- 1/4" Lock Washers (6)
- 1/4" Flat Washers (12)
- Hitch Guard Set-up Gauges (2)

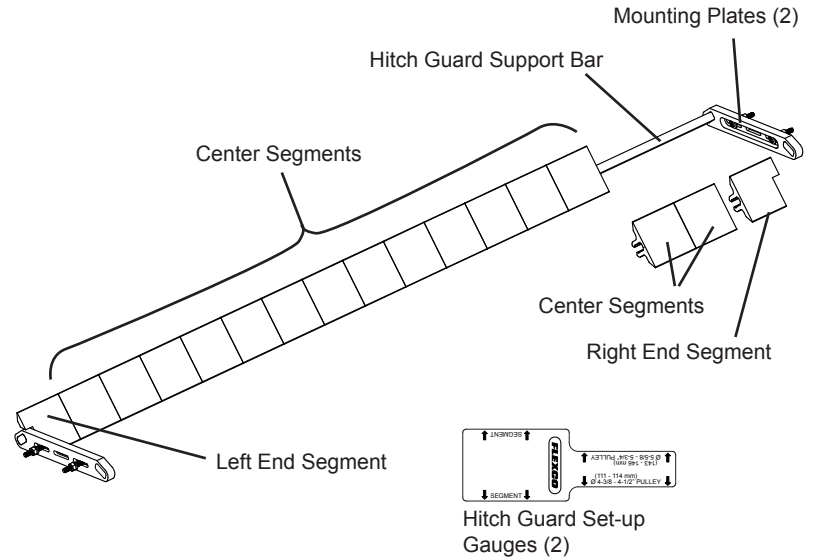

## Tools Required for Installation:

- Drill
- Cutoff Saw
- Table Saw
- 3/32" (2.4 mm) Drill Bit
- 9/32" (7 mm) Drill Bit
- Large Flat Head Screwdriver
- 1/4" (6 mm) Transfer Punch
- Steel Hammer
- Soft Face Mallet
- 7/16" (11 mm) Open End Wrench OR
- 7/16" (11 mm) Socket and Ratchet Drive
- 1/8" (3 mm) Hex Key

1. Measure head pulley diameter at hitch if diameter is not already known.
2. Measure inside-to-inside width of the side panels at hitch within 1/16" (1.5 mm) accuracy (Fig. 1).
3. Cut hitch guard support bar 1/16" to 1/8" (1.5 to 3 mm) shorter than measured dimension from Step 2. Deburr ends of hitch guard support bar if burrs are present.
4. Install all hitch guard segments onto pole, including left end and right end segments, leaving space for the last two center segments (Fig. 2).

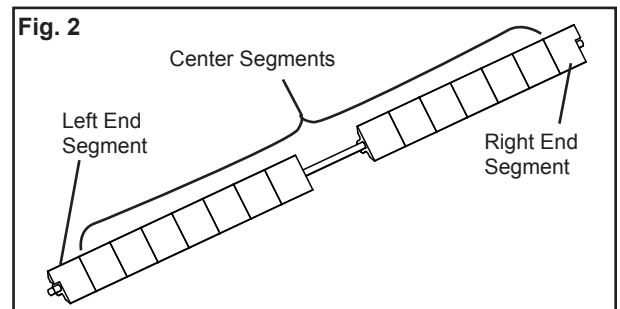
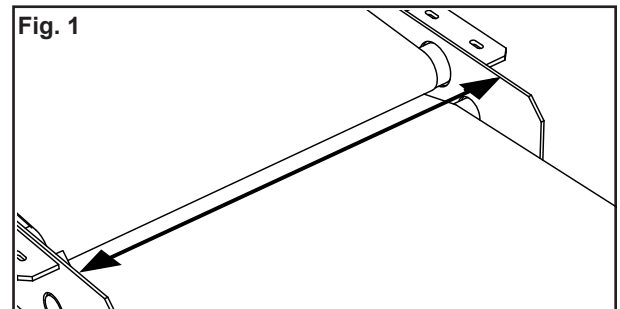

5. Slide steel mounting plates onto each end of support bar as shown, with recessed slotted side facing in towards conveyor belt (Fig. 3).
6. Place assembled hitch guard into position on conveyor belt, filling the gap in the hitch.
7. Using supplied Hitch Guard Set-up Gauges, place the corresponding pulley diameter side against top pulley and the segment indicated side against the flat face of the segment (Fig. 4).
8. Properly position the Hitch Guard by rotating the hitch guard until the segment side of the Set-up Gauge is flush with the flat face of the hitch guard, the pulley side of the gauge is resting against the top pulley/belt, and the lower edge of the hitch guard is making light contact with the lower belt (Fig. 5a & 5b). Fig. 5c illustrates proper finished segment orientation.
9. With hitch guard properly positioned, use transfer-punch and steel hammer or paint marker to transfer drill locations at the center of two of the three slots in the both mounting brackets. It is recommended that the two outermost slot locations be used. If this is not possible, the middle slot may be used as one of the two locations (Fig. 6). **NOTE:** To prevent movement of hitch guard or mounting plate, place knee or heavy object against flat surface of segments or have a helper hold the bar.
10. Remove hitch guard assembly. Using a 3/32" (2.4 mm) drill bit, drill pilot hole. Finish drilling hole with a 9/32" (7 mm) drill bit. Remove burrs.
11. Return hitch guard assembly to mounting position.

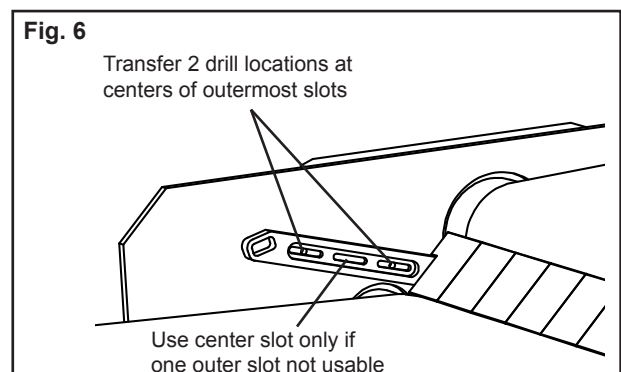
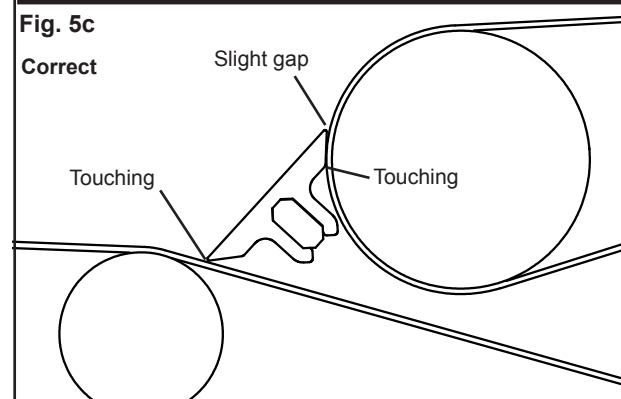
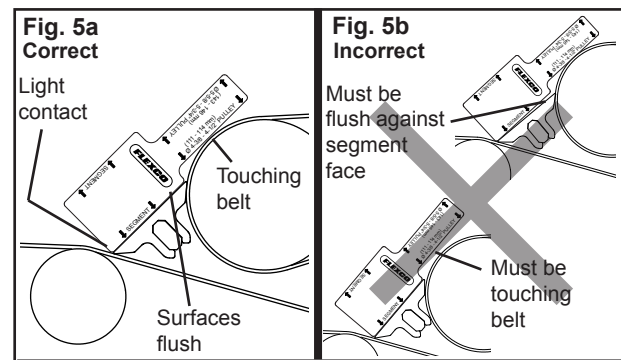
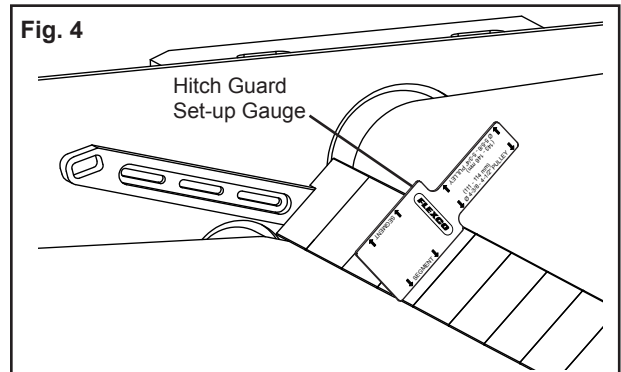
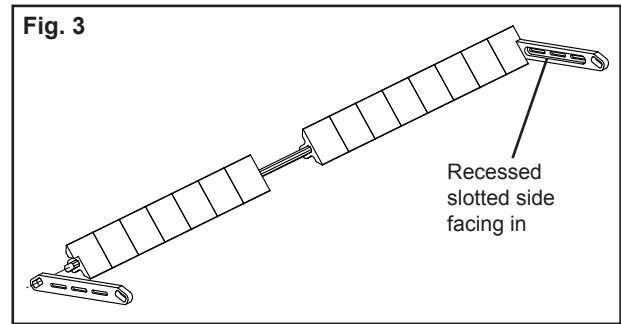

12. Insert 1/4"-20 x 1.5" cap screw with 1/4" flat washer through mounting plate and drilled holes in side panels. On outside surface of side panel, loosely install 1/4" flat washer, 1/4" lock washer, and nut on each cap screw end (Fig. 7). Complete this step for all remaining mounting locations.

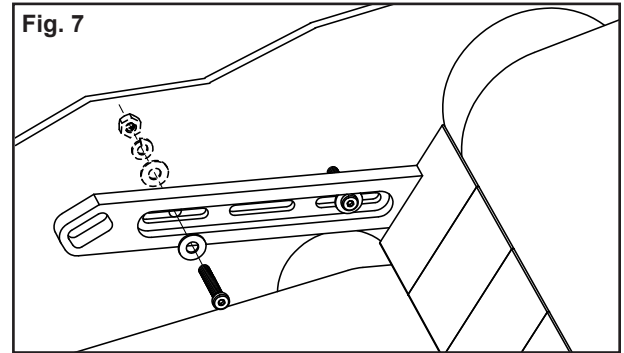

13. Use included set-up gauges to verify position of hitch guard before final tightening of hardware (see Steps 7 & 8).

14. Insert 1/8" (3 mm) hex key in cap screw on inside of conveyor panel (Fig. 8) while tightening 1/4"-20 nut on outside of conveyor panel with 7/16" (11 mm) open end wrench (or socket and ratchet drive).

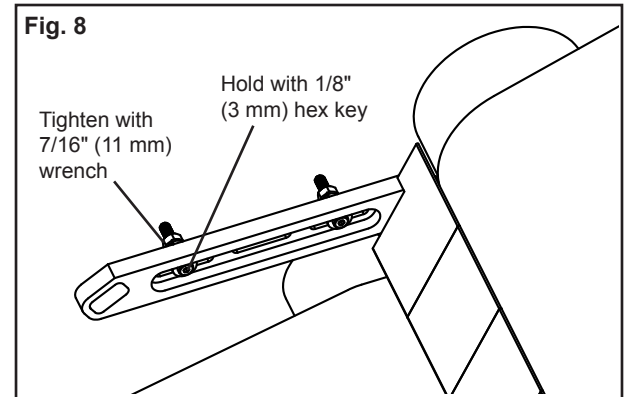

15. With a soft-faced mallet, tap right and left end segments onto support bar with notches nesting around mounting plates. Install remaining center segments.

16. **NOTE:** An exact number of segments may not fill the support bar. At the remaining unfilled segment location tightly push segments in opposite directions. Measure the "Max Width" of the gap (Fig. 9).

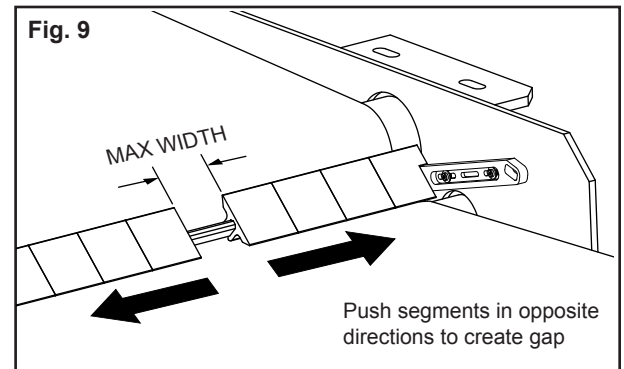

17. If MAX WIDTH is greater than 1.5" (38 mm), use table saw to cut a final segment to 1/16"-1/8" (1.5-3 mm) less than MAX WIDTH.

18. If MAX WIDTH is less than 1.5" (38 mm):

- Remove one additional segment adjacent to gap (Fig. 10).
- Measure MAX WIDTH opening and divide by 2. (X / 2)
- Using table saw, cut two final segments 1/32"-1/16" (1.5-3 mm) less than dimension in Step b above.

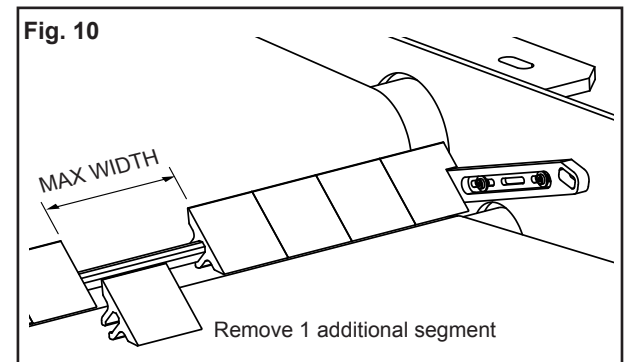

19. Install modified final segment(s), and then move all segments across support bar so they are tightly positioned together with total gap of 1/16"-1/8" (.8-1.5 mm) between one end segment and mounting plate. This will provide clearance for possible thermal expansion of segments.

2525 Wisconsin Avenue • Downers Grove, IL 60515-4200 • USA  
Tel: (800) 541-8028 • Fax: (630) 971-1180 • E-mail: [info@flexco.com](mailto:info@flexco.com)

Visit [www.flexco.com](http://www.flexco.com) for other Flexco locations and products.

©2021 Flexible Steel Lacing Company, 11/17/21. For reorder: X3627

