

MOTORIZED BRUSH CLEANER

Effective Cleaning Solution for Chevron, Cleated and Raised-rib Belts

Chevron, cleated and raised-rib belts present a special problem for efficient cleaning. The Motorized Brush Cleaner is an ideal option for cleaning these belts. It also performs well as the second or third cleaner in a system with worn or pitted belts, as the bristles effectively dislodge trapped material.

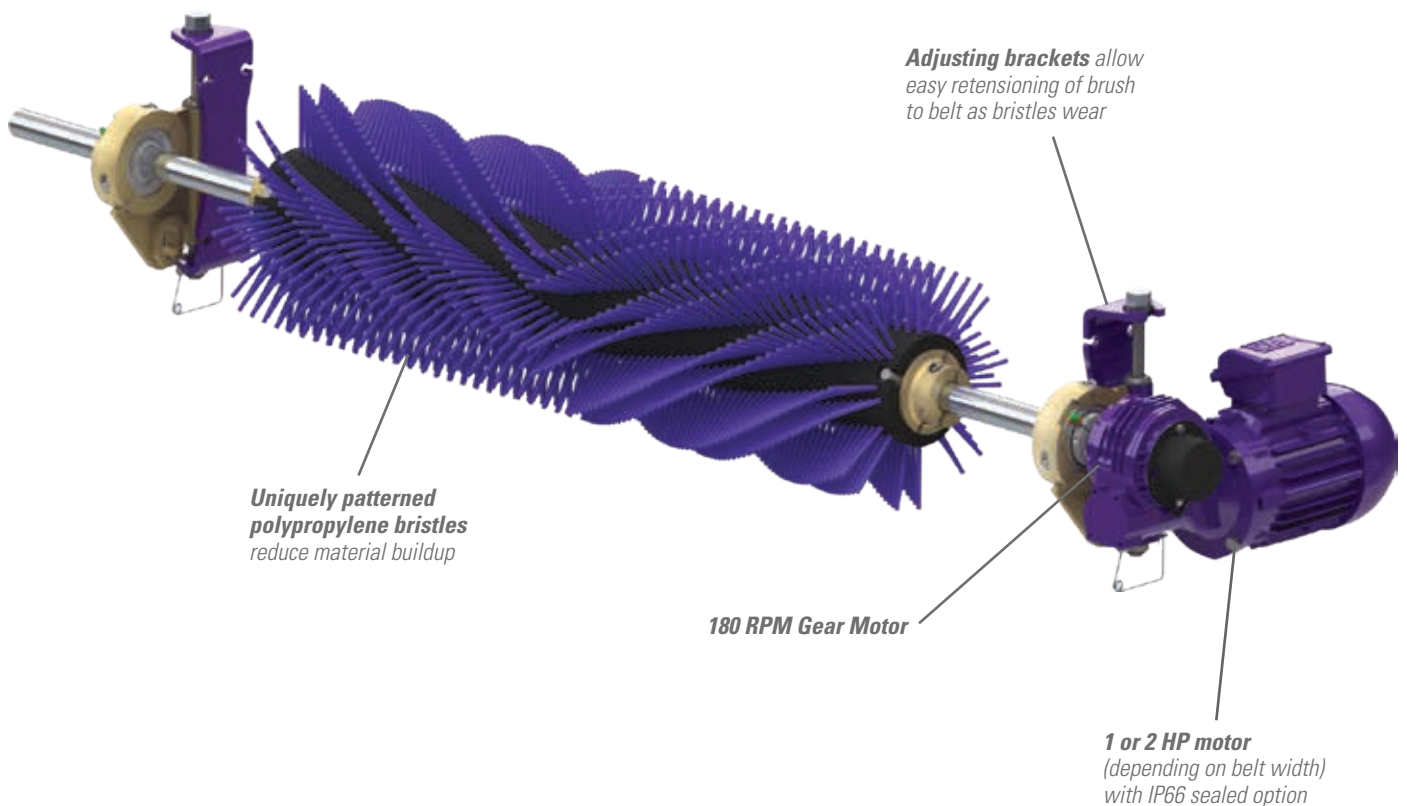

Features and Benefits

- **Maximum Cleaning.** Spins opposite the belt direction for optimal cleaning.
- **Uniquely patterned bristles.** Aids in reducing material buildup and clogging.
- **Adjustable tensioners.** Allows easy brush-to-belt adjustment as the bristles wear.
- **Works on mechanically spliced or vulcanized belts.**

MOTORIZED BRUSH CLEANER

Specifications and Guidelines

- **Maximum Belt Speed**
700 FPM (3.5 m/s)
- **Temperature Rating**
-20°F to 180° F (-30° C to 82° C)
- **CEMA Cleaner Rating**
Class 4
- **Overall Brush Diameter**
12" (305mm)
- **Bristle Material**
Polypropylene
- **Bristle Length**
3-1/4" (83mm)
- **Brush RPM**
180
- **Shaft Diameter**
1-7/16" (36.5mm)
- **Shaft Length**
Belt Width + 42" (1067mm)
- **Maximum Chevron or Cleat Height**
1/2" (13mm)
- **Motor Voltage and HP**
208-230/460VAC 3 Phase*
1HP (Cleaners 18-42" (450-1050mm))
2HP (Cleaners 48-84" (1200-2100mm))
575V 3 Phase*
1HP (Cleaners 18-36" (450-900mm))
2HP (Cleaners 42-84" (1050-2100mm))
*other motors available upon request
- **Motor Ingress Protection**
IP55 or IP66
- **Available for Belt Widths**
18" to 84" (450 to 2100mm)
- **Horizontal Clearance Required**
12" (305mm)
- **Vertical Clearance Required**
12" (305mm)

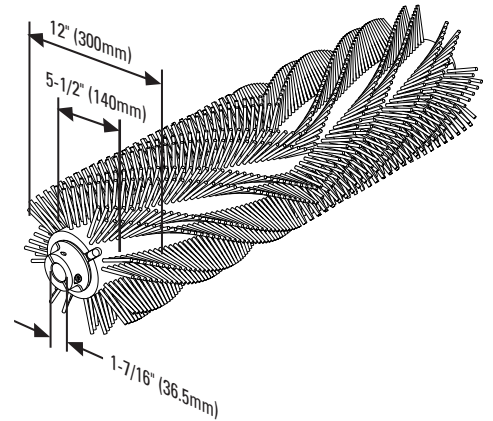
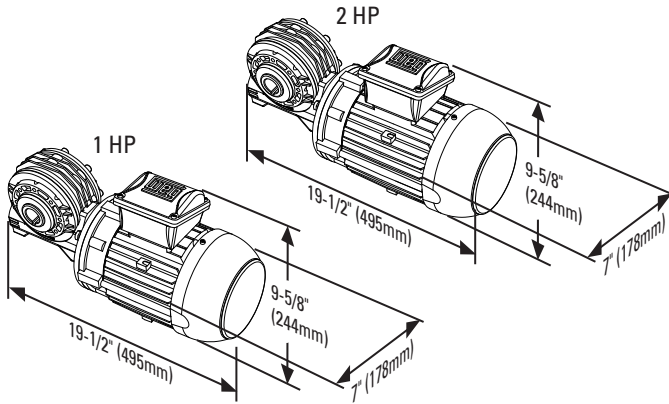

Shaft Measurements

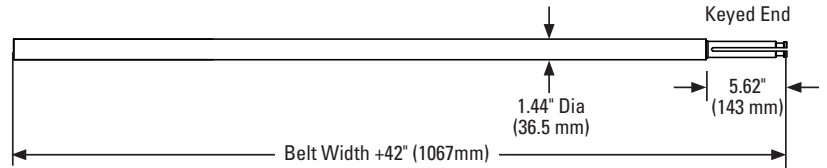

Ordering Information

Motorized Brush Cleaner 208-230/460 VAC 3-Phase Motor					
Belt Width		Brush Coverage		Ordering Number	Item Code
in.	mm	in.	mm		
				IP55	
				IP66	
18	450	18	450	MBC-18	79494
24	600	24	600	MBC-24	79495
30	750	30	750	MBC-30	79496
36	900	36	900	MBC-36	79497
42	1050	42	1050	MBC-42	79498
48	1200	48	1200	MBC-48	79499
54	1350	54	1350	MBC-54	79500
60	1500	60	1500	MBC-60	79501
72	1800	72	1800	MBC-72	79502
84	2100	84	2100	MBC-84	79503
				MBC-18-S	91571
				MBC-24-S	91572
				MBC-30-S	91573
				MBC-36-S	91574
				MBC-42-S	91575
				MBC-48-S	91576
				MBC-54-S	91577
				MBC-60-S	91578
				MBC-72-S	91579
				MBC-84-S	91580

Motorized Brush Cleaner 575V 3-Phase Motor					
Belt Width		Brush Coverage		Ordering Number	Item Code
in.	mm	in.	mm		
				IP55	
				IP66	
18	450	18	450	MBC-18-575V	79914
24	600	24	600	MBC-24-575V	79915
30	750	30	750	MBC-30-575V	79916
36	900	36	900	MBC-36-575V	79917
42	1050	42	1050	MBC-42-575V	79918
48	1200	48	1200	MBC-48-575V	79919
54	1350	54	1350	MBC-54-575V	79920
60	1500	60	1500	MBC-60-575V	79921
72	1800	72	1800	MBC-72-575V	79922
84	2100	84	2100	MBC-84-575V	79923
				MBC-18-575V-S	91581
				MBC-24-575V-S	91582
				MBC-30-575V-S	91583
				MBC-36-575V-S	91584
				MBC-42-575V-S	91585
				MBC-48-575V-S	91586
				MBC-54-575V-S	91587
				MBC-60-575V-S	91588
				MBC-72-575V-S	91589
				MBC-84-575V-S	91590

Replacement Brushes	
Ordering Number	Item Code
MBRD-18	79514
MBRD-24	79515
MBRD-30	79516
MBRD-36	79517
MBRD-42	79518
MBRD-48	79519
MBRD-54	79520
MBRD-60	79521
MBRD-72	79522
MBRD-84	79523

Lead time: 1 working day

Authorized Distributor:



2525 Wisconsin Avenue • Downers Grove, IL 60515-4200 • USA
Tel: (630) 971-0150 • Fax: (630) 971-1180 • E-mail: info@flexco.com

Visit www.flexco.com for other Flexco locations and products.

©2020 Flexible Steel Lacing Company, 11/19/20. For reorder: X3594

