

MHS HD Secondary Belt Cleaner

Installation, Operation and Maintenance Manual

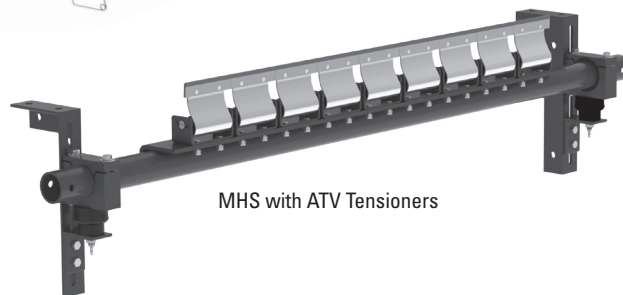
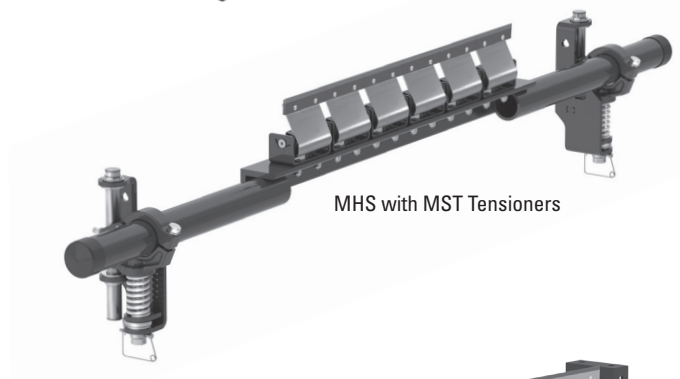
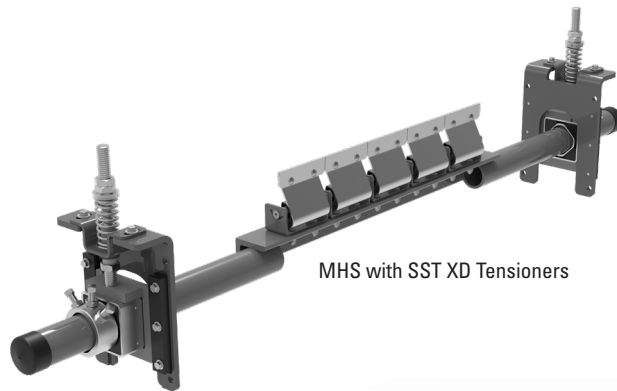

MHS HD Secondary Cleaner

Purchase Date: _____

Purchased From: _____

Installation Date: _____

This information will be helpful for any future inquiries or questions about belt cleaner replacement parts, specifications or troubleshooting.

Table of Contents

Section 1 - Important Information	4
1.1 General Introduction.....	4
1.2 User Benefits	4
1.3 Service Option.....	4
Section 2 - Safety Considerations and Precautions	5
2.1 Stationary Conveyors.....	5
2.2 Operating Conveyors.....	5
Section 3 - Pre-Installation Checks and Options.....	6
3.1 Checklist.....	6
3.2 Optional Installation Accessories.....	7
Section 4 - Installation Instructions.....	8
4.1 MHS HD - SST XD Tensioner.....	8
4.2 MHS HD - SST XD Push-Up Tensioning.....	11
4.3 MHS HD - MST Tensioner	12
4.4 MHS HD - ATV Tensioner	15
Section 5 - Pre-Operation Checklist and Testing.....	18
5.1 Pre-Op Checklist.....	18
5.2 Test Run the Conveyor	18
Section 6 - Maintenance.....	19
6.1 New Installation Inspection	19
6.2 Routine Visual Inspection.....	19
6.3 Routine Physical Inspection	19
6.4 Maintenance Log.....	20
6.5 Cleaner Maintenance Checklist.....	21
Section 7 - Troubleshooting	22
Section 8 - Specs and CAD Drawing	23
8.1 Specs and Guidelines	23
8.2 CAD Drawing - MHS HD - SST XD.....	24
8.3 CAD Drawing - MHS HD - MST	25
8.4 CAD Drawing - MHS HD - ATV	26
Section 9 - Replacement Parts	27
9.1 Replacement Parts - MHS HD	27
9.1 Replacement Parts - Optional MST and ATV Tensioners.....	28
9.2 Replacement Blades - MHS Stainless Steel	29
Section 10 - Other Flexco Conveyor Products.....	31

Section 1 - Important Information

1.1 General Introduction

We at Flexco are very pleased that you have selected an MHS HD Secondary Cleaner for your conveyor system.

This manual will help you to understand the operation of this product and assist you in making it work up to its maximum efficiency over its lifetime of service.

It is essential for safe and efficient operation that the information and guidelines presented be properly understood and implemented. This manual will provide safety precautions, installation instructions, maintenance procedures and troubleshooting tips.

If, however, you have any questions or problems that are not covered, please contact your field representative or our Customer Service Department.

Visit www.flexco.com for other Flexco locations and products.

Please read this manual thoroughly and pass it on to any others who will be directly responsible for installation, operation and maintenance of this cleaner. While we have tried to make the installation and service tasks as easy and simple as possible, **it does however require correct installation and regular inspections and adjustments to maintain top working condition.**

1.2 User Benefits

Correct installation and regular maintenance will provide the following benefits for your operation:

- Reduced conveyor downtime
- Reduced man-hour labour
- Lower maintenance budget costs
- Increased service life for the belt cleaner and other conveyor components

1.3 Service Option

The MHS HD Secondary Cleaner is designed to be easily installed and serviced by your on-site personnel. However, if you would prefer complete turn-key factory service, please contact your local Flexco Field Representative.

Section 2 - Safety Considerations and Precautions

Before installing and operating the MHS HD Secondary Cleaner, it is important to review and understand the following safety information.

There are set-up, maintenance and operational activities involving both **stationary** and **operating** conveyors. Each case has a safety protocol.

2.1 Stationary Conveyors

The following activities are performed on stationary conveyors:

- Installation
- Blade replacement
- Repairs
- Tension adjustments
- Cleaning

DANGER

It is imperative that Lockout/Tagout (LOTO) regulations, be followed before undertaking the preceding activities. Failure to use LOTO exposes workers to uncontrolled behaviour of the belt cleaner caused by movement of the conveyor belt. Severe injury or death can result.

Before working:

- Lockout/Tagout the conveyor power source.
- Disengage any takeups.
- Clear the conveyor belt or clamp securely in place.

WARNING

Use Personal Protective Equipment (PPE):

- Safety eyewear
- Hardhats
- Safety footwear

Close quarters, springs and heavy components create a worksite that compromises a worker's eyes, feet and skull. PPE must be worn to control the foreseeable hazards associated with conveyor belt cleaners. Serious injuries can be avoided.

2.2 Operating Conveyors

There are two routine tasks that must be performed while the conveyor is running:

- Inspection of the cleaning performance.
- Dynamic troubleshooting.

DANGER

Every belt cleaner is an in-running nip hazard. Never touch or prod an operating cleaner. Cleaner hazards may cause instantaneous amputation and entrapment.

WARNING

Belt cleaners can become projectile hazards. Stay as far from the cleaner as practical and use safety eyewear and headgear. Missiles can inflict serious injury.

WARNING

Never adjust anything on an operating cleaner. Unforeseeable belt projections and tears can catch on cleaners and cause violent movements of the cleaner structure. Flailing hardware can cause serious injury or death.

Section 3 - Pre-installation Checks and Options

3.1 Checklist

- Check that the cleaner size is correct for the beltline width.
- Check the belt cleaner carton and make sure all the parts are included.
- Review the “Tools Needed” list on the top of the installation instructions.
- Check the conveyor site:
 - Will the cleaner be installed on a chute?
 - Is the install on an open head pulley requiring mounting structure?
(see 3.2 - Optional Installation Accessories)

Section 3 - Pre-installation Checks and Options

3.2 Optional Installation Accessories

Versatile, adjustable brackets that can be mounted on the conveyor structure so the MHS HD Secondary Cleaner can be quickly and easily bolted into place. Pole extenders are also available for wide, non-standard conveyor structures.

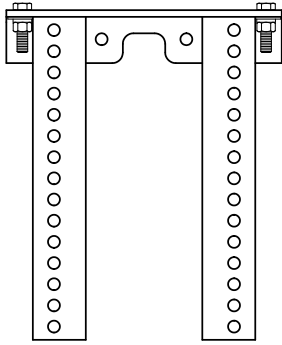

SST Standard Mounting Bracket Kit (for SST XD Tensioner)
(Item Code: 76071)

- For most secondary cleaner installs.
- 325 x 388 mm (13 x 15-1/2")

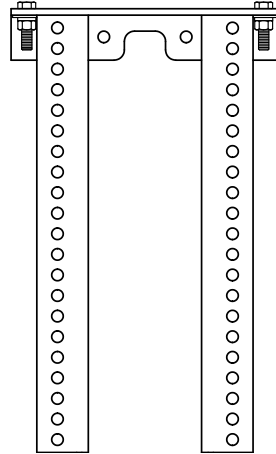

SST Long Mounting Bracket Kit (for SST XD Tensioner)
(Item Code: 76072)

- For installations that require extra length legs.
- 325 x 538 mm (13 x 21-1/2")

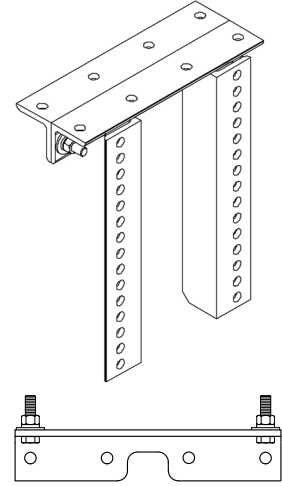

SST Optional Top Angle Kit (for SST XD Tensioner)
(Item Code: 76073)

- Used with both standard and long mounting bracket kits for additional mounting options.
- 325 mm (13")

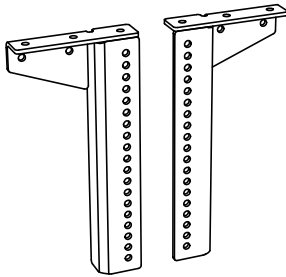

MST Drop Bracket Kit (for MST Tensioner Only)
(incl. 2 brackets)
(Item Code: 79434)

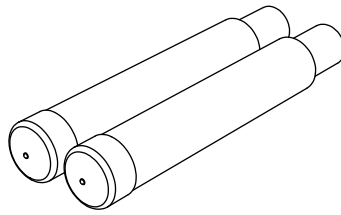

Pole Extender Kit (incl. 2 pole extenders)
(Item Code: 76024)

- For cleaner sizes 1800 mm (72") and larger
- Provides 750 mm (30") of extended pole length

Optional Mounting Kits (includes 2 brackets/bars)

DESCRIPTION	ORDERING NUMBER	ITEM CODE	WT. KG
Standard Mounting Bracket Kit *	SSTSMB	76071	15.6
Long Mounting Bracket Kit *	SSTLMB	76072	19.7
Optional Top Angle Kit *	SSTOTA	76073	4.8
Pole Extender Kit	MAPEK	76024	9.9
MST Drop Bracket Kit	MSTDDB	79434	12.6

*Hardware Included
Lead time: 1 working day

Section 4 - Installation Instructions

4.1 MHS HD - SST XD Tensioner

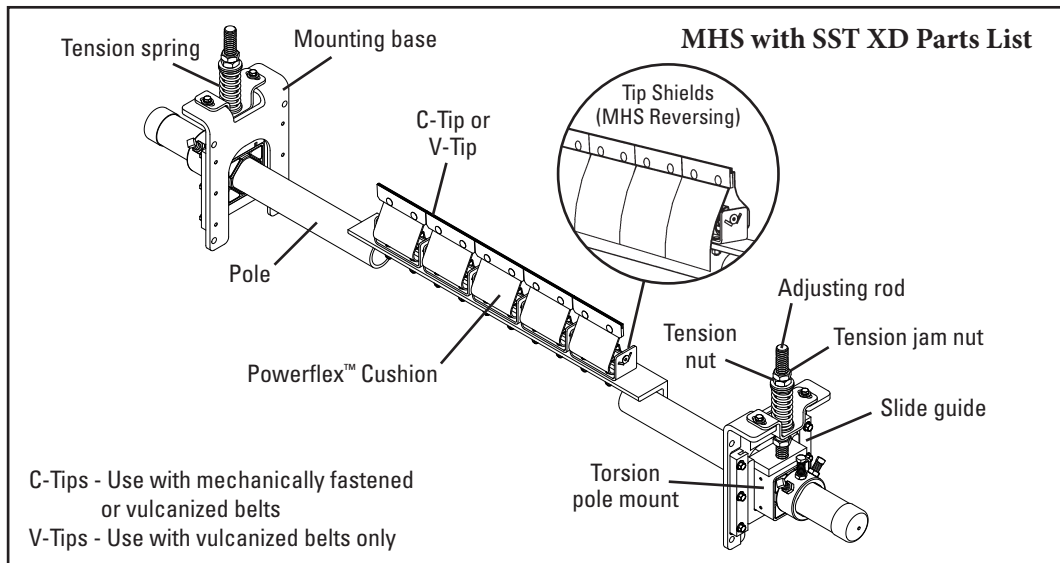

Physically lock out and tag the conveyor at the power source before you begin cleaner installation.

Tools Needed:

- 14 mm (9/16") Wrench
- 19 mm (3/4") Wrench
- 22 mm (7/8") Wrench
- 35 mm (1-3/8") Wrench
- OR Large Adjustable/
Crescent Wrenches (x2)
- Clamps (x2)
- Torch (as needed)
- Welder (as needed)
- Tape Measure
- Level
- Marking Pen or Soapstone

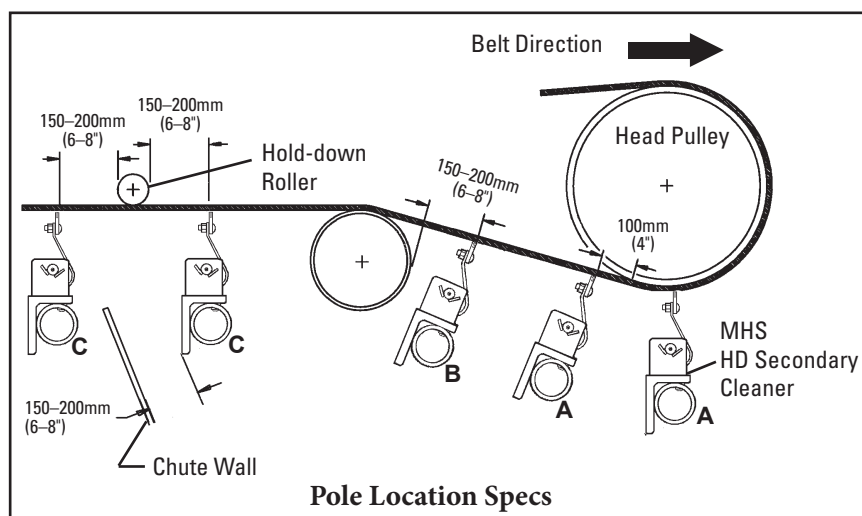

Section 4 - Installation Instructions

4.1 MHS HD - SST XD Tensioner

1. Install the spring tensioner mounting bases.

(For push-up tensioning refer to additional instructions on Page 10.) Clamp the mounting base into position so the top flange of the base is aligned with the belt line (Fig. 1a). Bolt or weld the mounting base in place. Locate and install the mounting base on the opposite side. Adjust the tension nuts on each side so the center of the torsion pole mount is 225 mm (9") below the belt line.

NOTE: For chute mounting, a belt location line must be drawn on the chute wall so the mounting base can be aligned with the belt (Fig. 1b). Cut access holes as needed (Fig. 1c).

2. Install the pole.

Slide the pole into one torsion pole mount as far as needed and locate the other end into the opposite mount (Fig. 2a). If there is not enough space, remove one of the torsion pole mounts from the mounting base, slide the pole through the mounting base and reassemble (Fig. 2b).

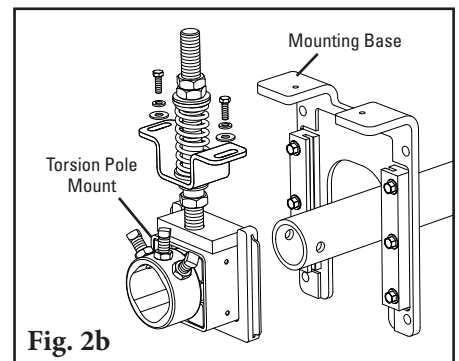
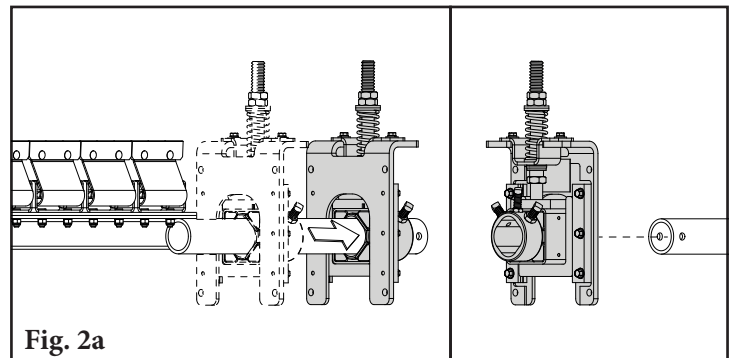
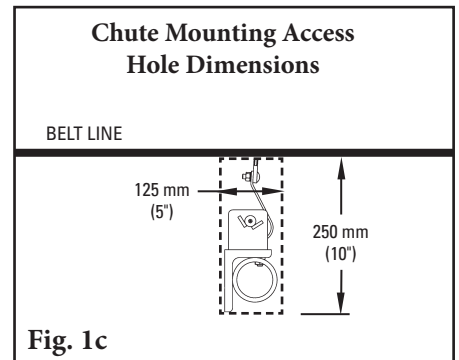
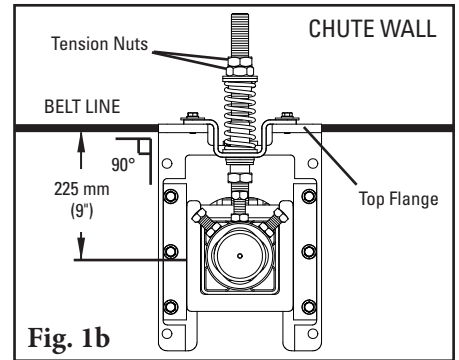
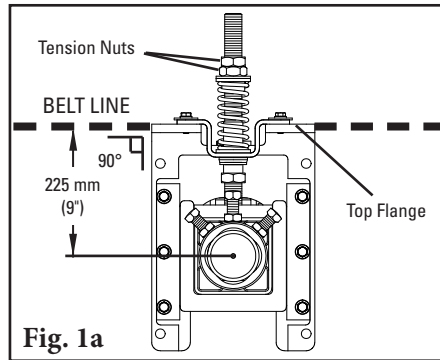

Section 4 - Installation Instructions

4.1 MHS HD - SST XD Tensioner

3. **Set the blade angle.** Center the pole/blades on the belt.

For MHS Standard: Rotate the pole until the tips align with the white “MHS Standard” side of the tip setup gauge provided (Fig. 3a).

For MHS Reversing: Rotate the pole until the tips are perpendicular to the belt, using the black “MHS Reversing” side of the tip setup gauge provided (Fig. 3b).

Tighten the three locking bolts on each torsion pole mount to lock the pole in place (Fig. 3c). Best practice is to tighten the middle bolt before tightening the outer bolts to ensure everything is secure. There should be no blade-to-belt contact while locking the pole in the correct position. If contact occurs, double check the dimension from Step 1.

- 4. **Set the blade tension.** Loosen the top tension jam nuts on both sides. Turn the tension nuts until the correct spring compression is reached. Spring compression is determined by spring length. See the chart at right for the correct spring length for your belt width.
- 5. **Set adjusting rod sleeve.** After setting the blade tension, screw the adjusting rod sleeve into the UHMW bushing until 38 mm (1-1/2") is showing (Fig. 4). Tighten the adjusting rod sleeve jam nut.
- 6. **Test run the cleaner and inspect the cleaning performance.** If vibration occurs or more cleaning efficiency is desired, increase the blade tension by making 3 mm (1/8") compression adjustments on the tension springs.

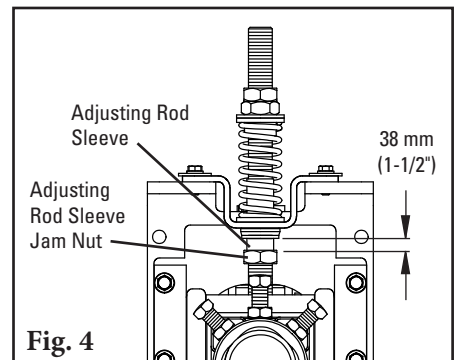
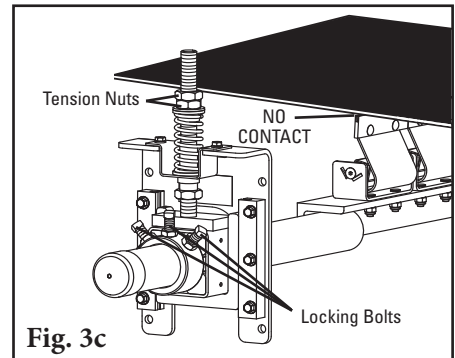
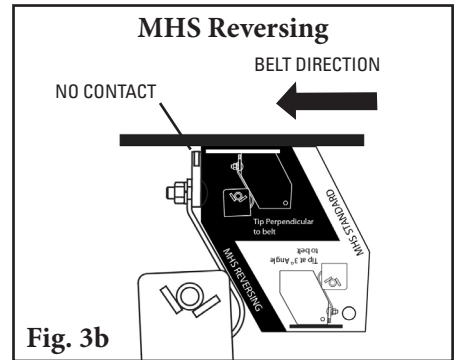
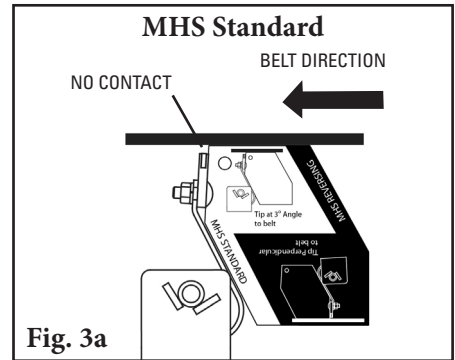

SST XD Spring Length Chart

Belt Width		White Springs		Silver Springs		Black Springs		Gold Springs	
mm	in.	mm	in.	mm	in.	mm	in.	mm	in.
450	18	86	3 3/8	102	4	N/A	N/A	N/A	N/A
600	24	79	3 1/8	98	3 7/8	N/A	N/A	N/A	N/A
750	30	73	2 7/8	95	3 3/4	N/A	N/A	N/A	N/A
900	36	N/A	N/A	95	3 3/4	98	3 7/8	N/A	N/A
1050	42	N/A	N/A	92	3 5/8	95	3 3/4	N/A	N/A
1200	48	N/A	N/A	89	3 1/2	92	3 5/8	N/A	N/A
1350	54	N/A	N/A	86	3 3/8	92	3 5/8	95	3 3/4
1500	60	N/A	N/A	83	3 1/4	89	3 1/2	95	3 3/4
1800	72	N/A	N/A	N/A	N/A	86	3 3/8	92	3 5/8
2100	84	N/A	N/A	N/A	N/A	79	3 1/8	89	3 1/2
2400	96	N/A	N/A	N/A	N/A	N/A	N/A	86	3 3/8

Shading indicates preferred spring option.

Section 4 - Installation Instructions

4.2 MHS HD - SST XD Push-Up Tensioning

1. **Reconfigure the standard pull-up tensioner to the push-up style.** Remove the 3 tension nuts, the flat washer, 2 bushings, the spring, the sleeve and the hat bracket; reassemble (Fig. 1) with 2 tension nuts, the flat washer, 2 bushings, the spring and the hat bracket on the upper end of the adjusting rod. Add washer (from instruction packet) and 3rd tension nut to bottom of the adjusting rod.
2. **Install the tensioner mounting bases.** Mount the bases to the structure or chute so that the tops of the base legs are 83 mm (3-1/4") below the belt (Fig. 1).
3. **Install the cleaner pole and set the blade angle.** Follow the installation steps from the cleaner instructions on Page 8.

Note: be sure the lock bolts on the torsion pole mount have been securely tightened to lock the pole in place before moving to Step 4. Best practice is to first tighten the middle bolt before tightening the outer bolts to ensure everything is secure.

4. **Set the blade tension.** Remove the bottom tension nut and washer from the adjusting rod. Turn the two upper tension nuts until the spring is compressed to the length shown on the Spring Length Chart below. Tighten the two tension nuts together to prevent loosening.
5. **Replace the sleeve.** Position the sleeve over the adjusting rod and turn it until it is in the middle of the bushing. Replace the bottom tension nut and tighten until it locks the sleeve in place (Fig. 2).

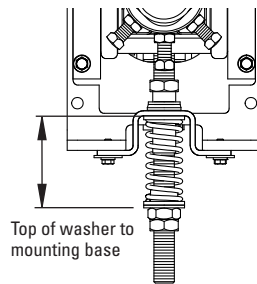
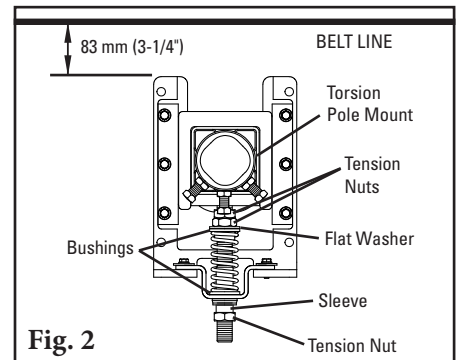
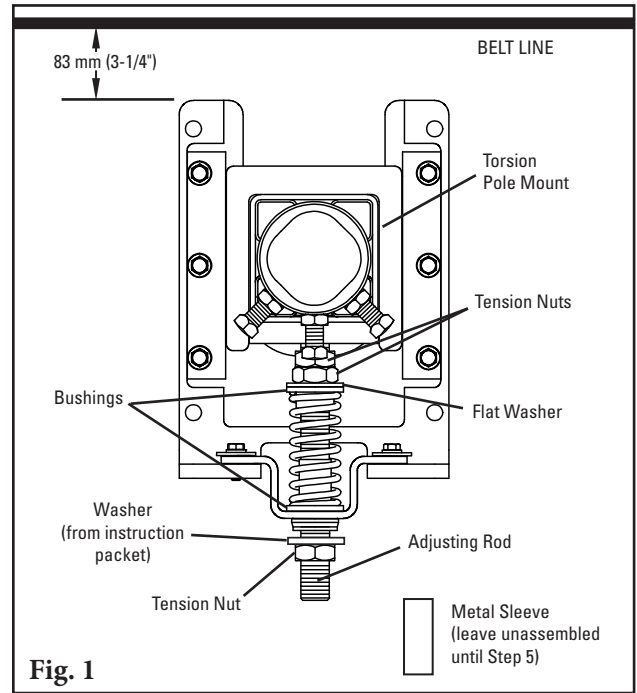

SST XD Spring Length Chart

Belt Width		White Springs		Silver Springs		Black Springs		Gold Springs	
mm	in.	mm	in.	mm	in.	mm	in.	mm	in.
450	18	86	3 3/8	102	4	N/A	N/A	N/A	N/A
600	24	79	3 1/8	98	3 7/8	N/A	N/A	N/A	N/A
750	30	73	2 7/8	95	3 3/4	N/A	N/A	N/A	N/A
900	36	N/A	N/A	95	3 3/4	98	3 7/8	N/A	N/A
1050	42	N/A	N/A	92	3 5/8	95	3 3/4	N/A	N/A
1200	48	N/A	N/A	89	3 1/2	92	3 5/8	N/A	N/A
1350	54	N/A	N/A	86	3 3/8	92	3 5/8	95	3 3/4
1500	60	N/A	N/A	83	3 1/4	89	3 1/2	95	3 3/4
1800	72	N/A	N/A	N/A	N/A	86	3 3/8	92	3 5/8
2100	84	N/A	N/A	N/A	N/A	79	3 1/8	89	3 1/2
2400	96	N/A	N/A	N/A	N/A	N/A	N/A	86	3 3/8

Shading indicates preferred spring option.

Section 4 - Installation Instructions

4.3 MHS HD - MST Tensioner (for belts 450–1800 mm (18–72"))

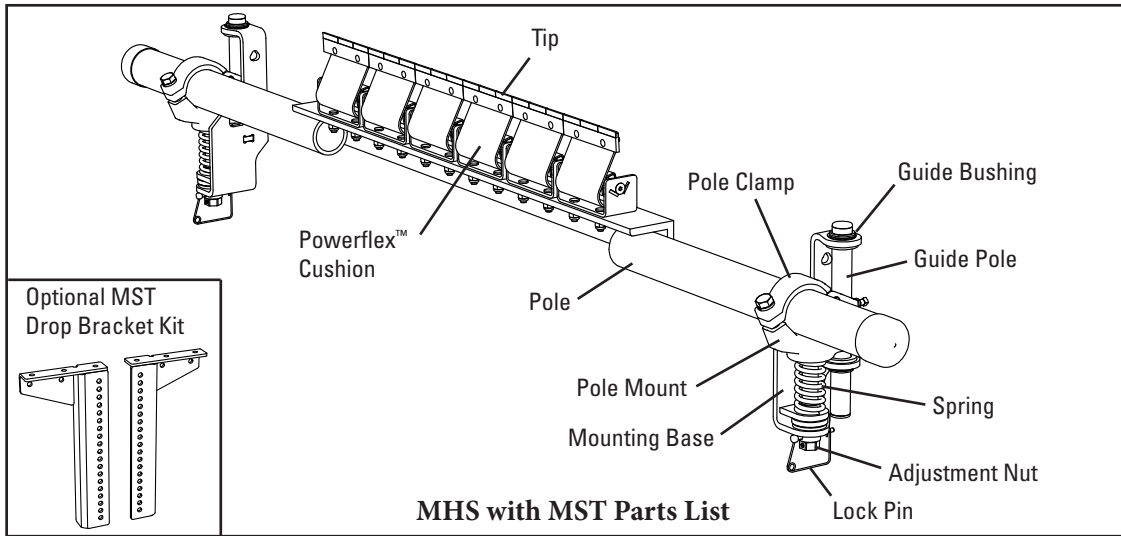

Physically lock out and tag the conveyor at the power source before you begin cleaner installation.

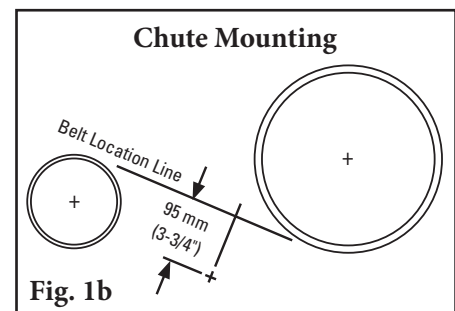
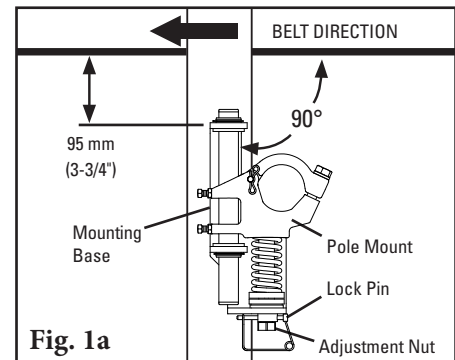
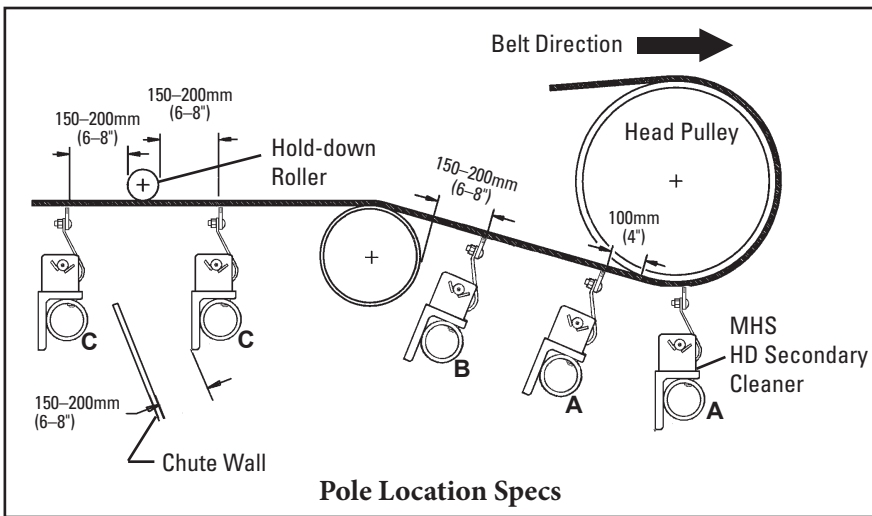

- 1. Install the spring tensioner mounting bases.** The preferred mounting orientation relative to belt direction is shown in Fig. 1a; if necessary the tensioners may be mounted with the opposite belt direction. Clamp the mounting base into position so the top flange is 95 mm (3-3/4") below the bottom of the belt. Bolt or weld the mounting base in place. Locate and install the mounting base on the opposite side. Remove the tensioner lock pins and turn the adjustment nuts to fully lower the pole mount.

Note: For chute mounting, a belt location line must be drawn on the chute wall so the mounting base can be aligned 95 mm (3-3/4") below the belt (Fig. 1b). Cut access holes as needed (Fig. 1c).

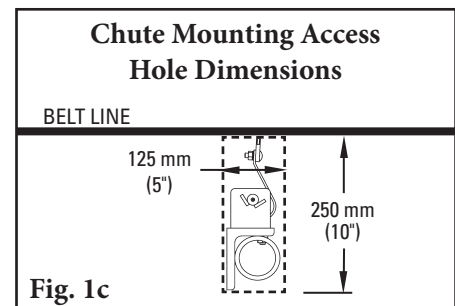

Section 4 - Installation Instructions

4.3 MHS HD - MST Tensioner (for belts 450–1800 mm (18–72"))

- Install the pole.** Remove pole clamp bolt and lift or remove top half of pole clamp from the tensioner on the near side of the conveyor, and loosen pole clamp bolt on the opposite side. Slide the pole across the conveyor and through the loosened pole clamp, then place the near end of pole in remaining pole clamp (Fig. 2). Replace top half of pole clamp, reinstall the bolt and tighten both bolts finger tight.
- Set the blade angle.** Center the pole/blades on the belt.

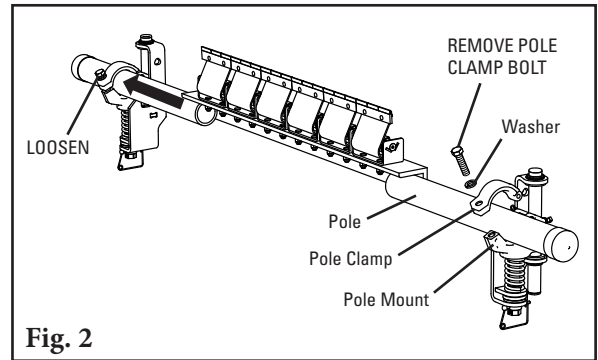

Fig. 2

For MHS Standard:

Rotate the pole until the tips align with the white “MHS Standard” side of the tip setup gauge provided (Fig. 3a).

For MHS Reversing:

Rotate the pole until the tips are perpendicular to the belt, using the black “MHS Reversing” side of the tip setup gauge provided (Fig. 3b).

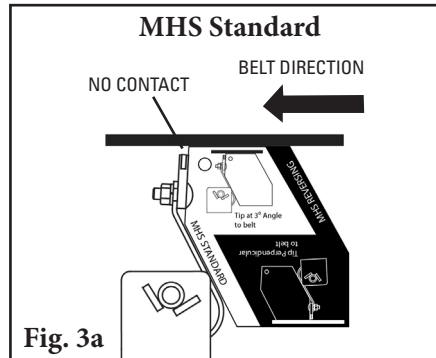

Fig. 3a

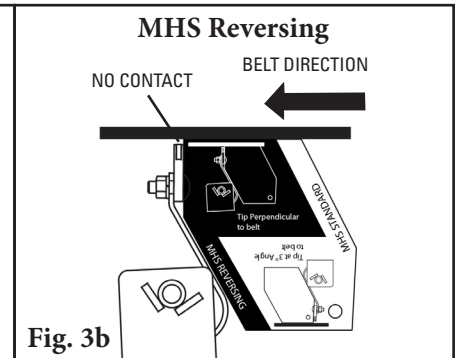

Fig. 3b

Tighten the pole clamp bolt on each pole mount to lock the pole in place. There should be no blade-to-belt contact while locking the pole in the correct position. If contact occurs, double check the dimension from Step 1.

- Ensure the tensioner travels freely.** Pull up and push down on each pole end to ensure the pole mount travels freely on the guide pole. If there is any sign of binding, loosen the bolts on the mounting base and pivot until the tensioner moves freely (Fig. 4). Retighten bolts.

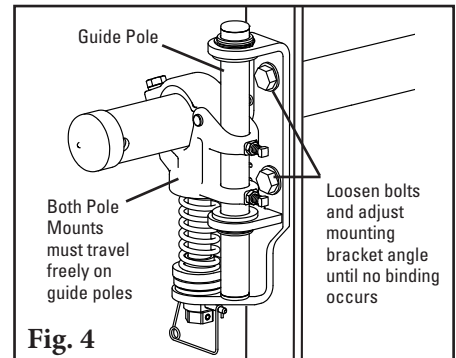

Fig. 4

- Set the blade tension.**

Turn the adjustment nut until the correct spring compression is reached (Fig. 5). Spring compression is determined by the spring length. See the chart below for the correct spring length for your belt width. Replace the locking pins.

MST Spring Length Chart

Belt Width		White Springs		Silver Springs		Black Springs	
mm	in.	mm	in.	mm	in.	mm	in.
450	18	73	2 7/8	86	3 3/8	89	3 1/2
600	24	67	2 5/8	86	3 3/8	86	3 3/8
750	30	60	2 3/8	83	3 1/4	86	3 3/8
900	36	54	2 1/8	79	3 1/8	83	3 1/4
1050	42	48	1 7/8	76	3	79	3 1/8
1200	48	N/A	N/A	73	2 7/8	79	3 1/8
1350	54	N/A	N/A	73	2 7/8	76	3
1500	60	N/A	N/A	70	2 3/4	73	2 7/8
1800	72	N/A	N/A	64	2 1/2	70	2 3/4

Shading indicates preferred spring option.

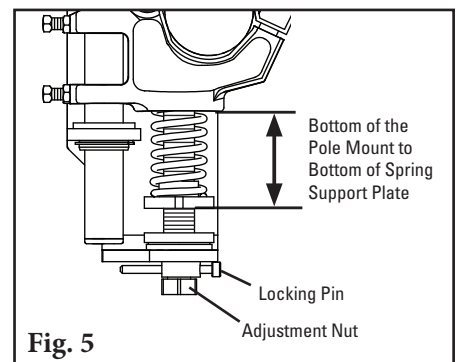
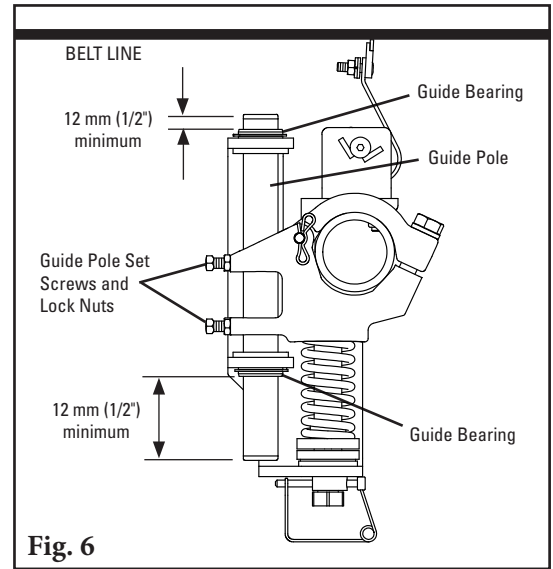

Fig. 5

Section 4 - Installation Instructions

4.3 MHS HD - MST Tensioner (for belts 450–1800 mm (18–72"))

6. **Secure guide poles.** Ensure the ends of the guide pole extend at least 12 mm (1/2") outside top and bottom guide bearings. If adjustment is necessary, loosen guide pole set screws and lock nuts, then tap guide pole up or down. Tighten guide pole set screws and lock nuts (Fig. 6).
7. **Check movement of each tensioner** to ensure they do not bind up. If there are binding concerns, refer to Step 4.
8. **Test run the cleaner and inspect the cleaning performance.** If vibration occurs or more cleaning efficiency is desired, increase the blade tension by making 3 mm (1/8") compression adjustments on the tension springs.



Section 4 - Installation Instructions

4.4 MHS HD - ATV Tensioner

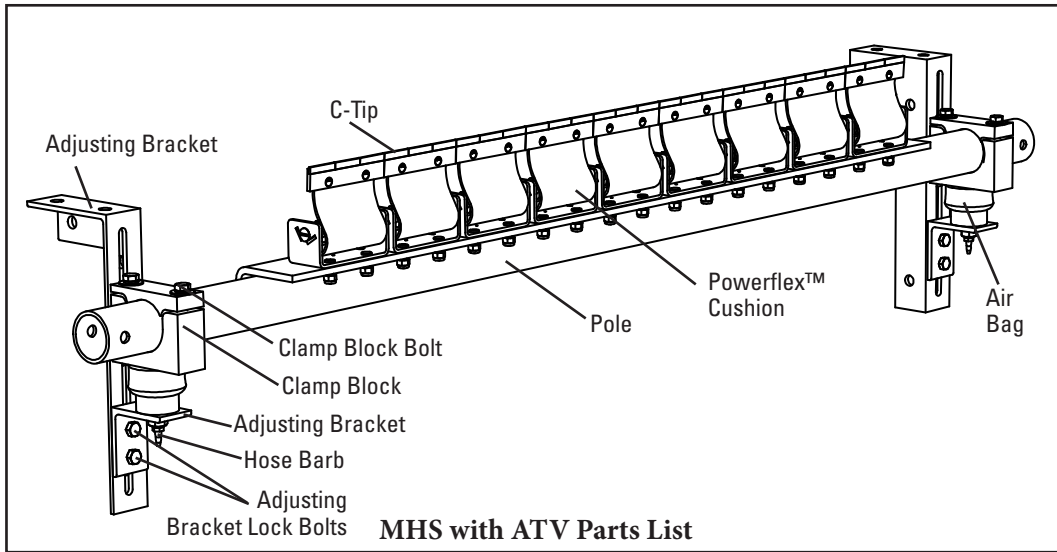

Physically lock out and tag the conveyor at the power source before you begin cleaner installation.

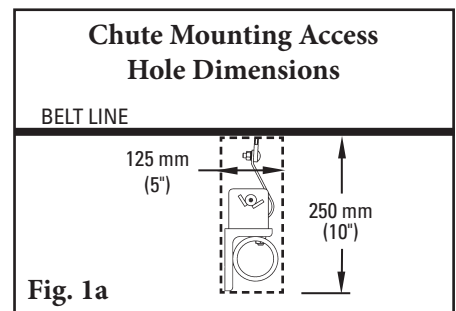
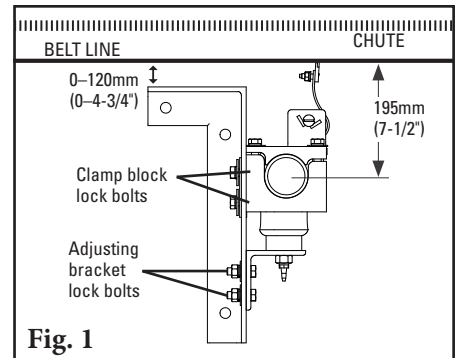
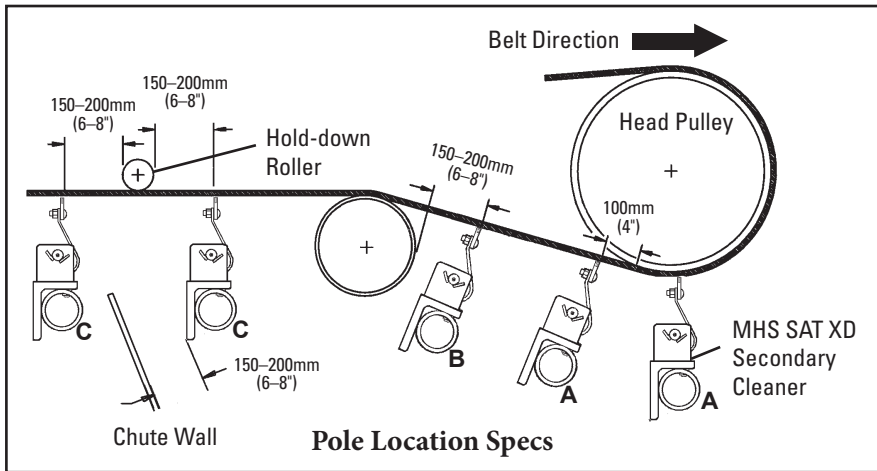

- 1. Install mounting brackets. For chute mounting:** For a chute installation a belt location line must first be established. Draw a line on the chute replicating this location. If head pulley and snub pulley are close, it may be necessary to assume an approximate belt line between the two. In the determined location draw a line perpendicular to the belt line.

Locate top of mounting bracket at 0–120 mm (0–4-3/4") from the belt line (Fig. 1). To move the clamp blocks, if necessary, loosen the clamp block lock bolts and the adjusting bracket lock bolt and move the clamp block to a position where the centre of the pole is 195 mm (5") below the bottom of the belt. Bolt or weld in place. Repeat this step on the opposite side. On one side an access hole may be required (Fig. 1a).

NOTE: The brackets must be aligned perpendicular to the belt.

Section 4 - Installation Instructions

4.4 MHS HD - ATV Tensioner

For structure mounting: In most applications the standard mounting brackets will have adequate room to fit on the structure with no cutting. Clamp the mounting bracket into position (use 150 mm (6") clamps). Move the clamp block to align the centre of the block with a point 195 mm (5") below the belt (Fig. 1b). To move the clamp blocks, if necessary, loosen the clamp block lock bolts and the adjusting bracket lock bolt and move the clamp block to a position where the centre of the hole is 195 mm (5") below the bottom of the belt. The bracket can now be bolted or welded in place. Locate and install bracket on the opposite side of belt in alignment with the first bracket.

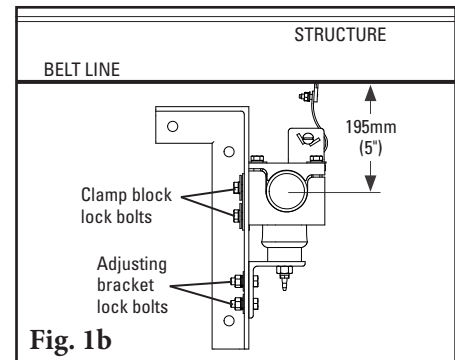

NOTE: The brackets must be aligned perpendicular to the belt.

- 2. Install the pole.** Remove the clamp block bolt from the access side clamp block and remove the upper half of the clamp block. On the opposite side clamp block, loosen the clamp block bolt enough to allow the pole to slide freely through (Fig. 2). Slide the pole across the belt, through the loosened clamp block, and locate into the cradle clamp block. Position the upper clamp block half over the pole and reinstall the clamp block bolt. Do not fully tighten.
- 3. Set the blade angle.** Centre the pole/blades on the belt. Rotate the pole until the tips are perpendicular to the belt (Fig. 3). Tighten the two locking bolts on each torsion pole mount to lock the pole in place (Fig. 3a). There should be no blade-to-belt contact while locking the pole in the correct position. If contact occurs, double-check the dimension from Step 1.

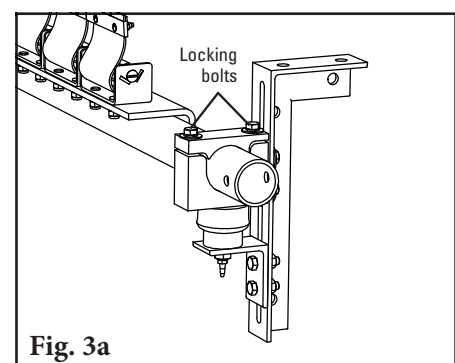
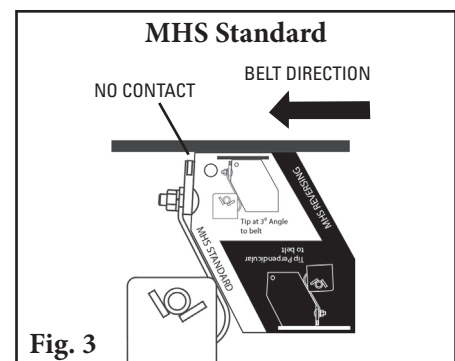
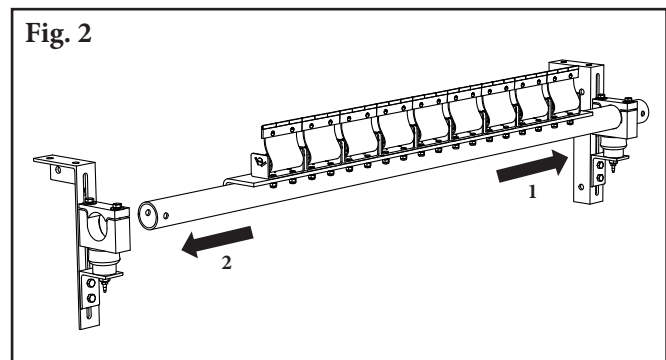

Section 4 - Installation Instructions

4.4 MHS HD - ATV Tensioner

4. **Connect the supply lines and set tension pressure.** With the parts supplied, attach a line to each air bag and run the lines to the outlet side of the control box (Fig. 4).

NOTE: Be sure lines are safely away from the belt. Connect the line from the inlet side of the box to the site's supply or air tank. Test the connections for leaks and set the pressure per the chart to the right. Pressure may be reduced to suit application.

5. **Test run the cleaner and inspect the cleaning performance.** If vibration occurs, increase tip layback by a small amount (approx. 3 degrees).

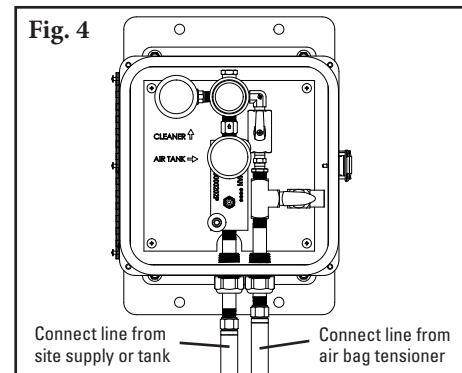

ATV Pressure Chart

Belt Width		Pressure	
mm	in.	kPa	psi
600	24	270	39
750	30	284	41
900	36	298	43
1050	42	311	45
1200	48	325	47
1350	54	339	49
1500	60	353	51
1800	72	380	55
2100	84	409	59
2400	96	438	63

Section 5 - Pre-Operation Checklist and Testing

5.1 Pre-Op Checklist

- Recheck that all fasteners are tightened properly.
- Add pole caps.
- Apply all supplied labels to the cleaner.
- Check the blade location on the belt.
- Be sure that all installation materials and tools have been removed from the belt and the conveyor area.

5.2 Test Run the Conveyor

- Run the conveyor for at least 15 minutes and inspect the cleaning performance.
- Check the tensioner spring for recommended length (proper tensioning).
- Make adjustments as necessary.

NOTE: Observing the cleaner when it is running and performing properly will help to detect problems or when adjustments are needed later.

Section 6 - Maintenance

Flexco belt cleaners are designed to operate with minimum maintenance. However, to maintain superior performance some service is required. When the cleaner is installed a regular maintenance program should be set up. This program will ensure that the cleaner operates at optimal efficiency and problems can be identified and fixed before the cleaner stops working.

All safety procedures for inspection of equipment (stationary or operating) must be observed. The MHS Belt Cleaner operates at the discharge end of the conveyor and is in direct contact with the moving belt. Only visual observations can be made while the belt is running. Service tasks can be done only with the conveyor stopped and by observing the correct lockout/tagout procedures.

6.1 New Installation Inspection

After the new cleaner has run for a few days a visual inspection should be made to ensure the cleaner is performing properly. Make adjustments as needed.

6.2 Routine Visual Inspection (every 2-4 weeks)

A visual inspection of the cleaner and belt should look for:

- If spring length is the correct length for optimal tensioning
- If belt looks clean or if there are areas that are dirty
- If blade is worn out and needs to be replaced
- If there is damage to the blade or other cleaner components
- If fugitive material is built up on cleaner or in the transfer area
- If there is cover damage to the belt
- If there is vibration or bouncing of the cleaner on the belt
- If a snub pulley is used, a check should be made for material buildup on the pulley
- Significant signs of carryback

If any of the above conditions exist, a determination should be made on when the conveyor can be stopped for cleaner maintenance.

6.3 Routine Physical Inspection (every 6-8 weeks)

When the conveyor is not in operation and properly locked and tagged out, a physical inspection of the cleaner to perform the following tasks:

- Clean material buildup off of the cleaner blade and pole
- Closely inspect the blade for wear and any damage. Replace if needed.
- Ensure full blade to belt contact
- Inspect the cleaner pole for damage
- Inspect all fasteners for tightness and wear. Tighten or replace as needed.
- Replace any worn or damaged components
- Check the tension of the cleaner blade to the belt. Adjust the tension if necessary using the chart on the cleaner or the one on Page 10 (SST XD spring tensioner), Page 13 (MST spring tensioner or Page 17 (ATV air tensioner).
- When maintenance tasks are completed, test run the conveyor to ensure the cleaner is performing properly

Section 6 - Maintenance

6.4 Maintenance Log

Conveyor Name/No. _____

Date: _____ Work done by: _____ Service Quote #: _____

Activity: _____

Date: _____ Work done by: _____ Service Quote #: _____

Activity: _____

Date: _____ Work done by: _____ Service Quote #: _____

Activity: _____

Date: _____ Work done by: _____ Service Quote #: _____

Activity: _____

Date: _____ Work done by: _____ Service Quote #: _____

Activity: _____

Date: _____ Work done by: _____ Service Quote #: _____

Activity: _____

Date: _____ Work done by: _____ Service Quote #: _____

Activity: _____

Date: _____ Work done by: _____ Service Quote #: _____

Activity: _____

Section 6 - Maintenance

6.5 Cleaner Maintenance Checklist

Site: _____ Inspected by: _____ Date: _____

Belt Cleaner: _____ Serial Number: _____

Beltline Information:

Beltline Number: _____ Belt Condition: _____

Belt Width: 450mm (18") 600mm (24") 750mm (30") 900mm (36") 1050mm (42") 1200mm (48") 1350mm (54") 1500mm (60") 1800mm (72") 2100mm (84") 2400mm (96")

Belt Speed: _____ m/s Belt Thickness: _____

Belt Splice: _____ Condition of Splice: _____ Number of splices: _____ Skived Unskived

Material conveyed: _____

Days per week run: _____ Hours per day run: _____

Blade Life::

Date blade installed: _____ Date blade inspected: _____ Estimated blade life: _____

Is blade making complete contact with belt? Yes No

Blade wear: Left _____ Middle _____ Right _____

Blade condition: Good Grooved Smiled Not contacting belt Damaged

Measurement of Spring: Required _____ Currently _____

For AVT Tensioner Only: Air/Nitrogen Pressure Required _____ Currently _____

Inspect Air Bags and Lines

Was Cleaner Adjusted: Yes No

Pole Condition: Good Bent Worn

Lagging: Slide lag Ceramic Rubber Other None

Condition of lagging: Good Bad Other _____

Cleaner's Overall Performance: (Rate the following 1 - 5, 1=very poor - 5= very good)

Appearance: Comments: _____

Location: Comments: _____

Maintenance: Comments: _____

Performance: Comments: _____

Other Comments: _____



Section 7 - Troubleshooting

Problem	Possible Cause	Possible Solutions
Vibration	Cleaner secure bolts not set	Ensure all locking nuts are tight (Loctite)
	Cleaner not set up correctly	Ensure cleaner set up properly (check tip angle with gauge) MHS Standard 1°-3° into belt; MHS Reversing and AVT perpendicular
	Belt tension too high	Ensure cleaner can conform to belt, or replace with alternate Flexco secondary cleaner
	Belt flap	Introduce hold-down roller to flatten belt
	Cleaner over-tensioned	Ensure cleaner is correctly tensioned
	Cleaner under-tensioned	Ensure cleaner is correctly tensioned
	Nylon bearing worn out or missing	Replace nylon bearing
Material buildup on cleaner	Cleaner not set up correctly	Ensure cleaner set up properly (1°-3° into belt)
	Buildup on chute	Ensure cleaner is not located too close to back of chute, allowing buildup
	Cleaner being overburdened	Introduce Flexco primary cleaner
	Excessive sticky material	Frequently clean unit of buildup
Damaged belt cover	Cleaner over-tensioned	Ensure cleaner is correctly tensioned
	Cleaner blade damage	Check blade for wear, damage and chips, replace where necessary
	Attack angle not correct	Ensure cleaner set up properly (check tip angle with gauge) MHS Standard 1°-3° into belt; MHS Reversing and AVT perpendicular
	Material buildup in chute	Frequently clean unit of buildup
Cleaner not conforming to belt	Cleaner not set up correctly	Ensure cleaner set up properly (check tip angle with gauge) MHS Standard 1°-3° into belt; MHS Reversing and AVT perpendicular
	Belt tension too high	Ensure cleaner can conform to belt (introduce hold-down roller), or replace with alternate Flexco secondary cleaner
	Belt flap	Introduce hold-down roller to flatten belt
	Cleaner cannot conform	Ensure cleaner can conform to belt (introduce hold-down roller), or replace with alternate Flexco secondary cleaner
Material passing cleaner	Cleaner not set up correctly	Ensure cleaner set up properly (check tip angle with gauge) MHS Standard 1°-3° into belt; MHS Reversing and AVT perpendicular
	Cleaner tension too low	Ensure cleaner is correctly tensioned
	Cleaner blade worn/damaged	Check blade for wear, damage and chips, replace where necessary
	Cleaner being overburdened	Introduce Flexco primary cleaner
	Belt flap	Introduce hold-down roller to flatten belt
	Belt worn or grooved	Introduce water spray pole
	Cleaner cannot conform	Ensure cleaner can conform to belt (introduce hold-down roller), or replace with alternate Flexco secondary cleaner
	Blade in backwards	Install blade correctly and set correct tension
Damage to mechanical fastener	Incorrect cleaner blade selection	Change blade type to accommodate fastener style (UC or UF)
	Belt not skived correctly	Spot and redo splice correctly, lowering the profile flush or below belt surface
	Blade angle incorrect	Reset with gauge
Missing material in belt centre only	Cupped Belt	Install hold-down roller and reset blade angle with gauge
	Cleaner blade worn/damaged	Check blade for wear, damage and chips, replace where necessary
Missing material on outer edges only	Cupped Belt	Install hold-down roller and reset blade angle with gauge
	Cleaner blade worn/damaged	Check blade for wear, damage and chips, replace where necessary
MST Tensioners binding	Tensioners not aligned properly	Adjust mounting bases until tensioners travel without binding
	Material buildup on tensioner guide pole	Clean off guide pole

Section 8 - Specs and CAD Drawings

8.1 Specs and Guidelines

Pole Length Specifications*

CLEANER SIZE		BLADE WIDTH		POLE LENGTH		MAXIMUM CONVEYOR SPAN	
mm	in.	mm	in.	mm	in.	mm	in.
600	24	600	24	1200	48	950	38
750	30	750	30	1350	54	1100	44
900	36	900	36	1500	60	1250	50
1050	42	1050	42	1650	66	1400	56
1200	48	1200	48	1800	72	1550	62
1350	54	1350	54	1950	78	1700	68
1500	60	1500	60	2200	80	1950	78
1800	72	1800	72	2350	86	2100	84
2100	84	2100	84	2650	98	2400	96
2400	96	2400	96	2950	110	2700	108

*For special extra long pole length requirements a Pole Extender Kit (#76024) is available that provides 750 mm (30") of extended pole length. See Page 7. Pole Diameter - 73 mm (2-7/8")

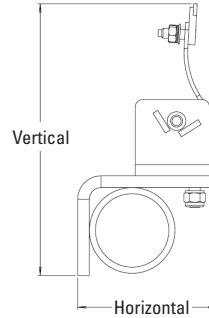
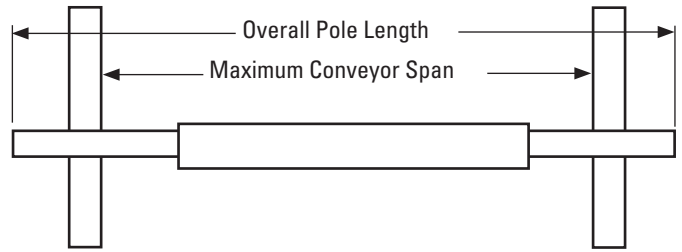

Clearance Guidelines for Installation

HORIZONTAL CLEARANCE REQUIRED		VERTICAL CLEARANCE REQUIRED	
mm	in.	mm	in.
127	5	254	10

SST XD Spring Length Chart

Belt Width		White Springs		Silver Springs		Black Springs		Gold Springs	
mm	in.	mm	in.	mm	in.	mm	in.	mm	in.
450	18	86	3 3/8	102	4	N/A	N/A	N/A	N/A
600	24	79	3 1/8	98	3 7/8	N/A	N/A	N/A	N/A
750	30	73	2 7/8	95	3 3/4	N/A	N/A	N/A	N/A
900	36	N/A	N/A	95	3 3/4	98	3 7/8	N/A	N/A
1050	42	N/A	N/A	92	3 5/8	95	3 3/4	N/A	N/A
1200	48	N/A	N/A	89	3 1/2	92	3 5/8	N/A	N/A
1350	54	N/A	N/A	86	3 3/8	92	3 5/8	95	3 3/4
1500	60	N/A	N/A	83	3 1/4	89	3 1/2	95	3 3/4
1800	72	N/A	N/A	N/A	N/A	86	3 3/8	92	3 5/8
2100	84	N/A	N/A	N/A	N/A	79	3 1/8	89	3 1/2
2400	96	N/A	N/A	N/A	N/A	N/A	N/A	86	3 3/8

Shading indicates preferred spring option.

SST XD

Top of Washer to Mounting Base

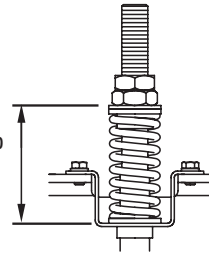

MST Spring Length Chart

Belt Width		White Springs		Silver Springs		Black Springs	
mm	in.	mm	in.	mm	in.	mm	in.
450	18	73	2 7/8	86	3 3/8	89	3 1/2
600	24	67	2 5/8	86	3 3/8	86	3 3/8
750	30	60	2 3/8	83	3 1/4	86	3 3/8
900	36	54	2 1/8	79	3 1/8	83	3 1/4
1050	42	48	1 7/8	76	3	79	3 1/8
1200	48	N/A	N/A	73	2 7/8	79	3 1/8
1350	54	N/A	N/A	73	2 7/8	76	3
1500	60	N/A	N/A	70	2 3/4	73	2 7/8
1800	72	N/A	N/A	64	2 1/2	70	2 3/4

Shading indicates preferred spring option.

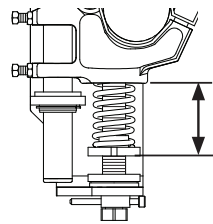

MST

Bottom of Pole Mount to Bottom of Spring Support Plate

ATV Pressure Chart

Belt Width		Pressure	
mm	in.	kPa	psi
600	24	270	39
750	30	284	41
900	36	298	43
1050	42	311	45
1200	48	325	47
1350	54	339	49
1500	60	353	51
1800	72	380	55
2100	84	409	59
2400	96	438	63

Specifications:

- Maximum Belt Speed **SST XD/ATV Tensioners:** 6 m/s (1200 FPM). **MST Tensioner:** 5 m/s (1000 FPM)
- Temperature Rating -35 to 82°C (-30 to 180°F)
- Usable Blade Wear Length 9 mm (3/8")
- Blade Materials **C-Tip:** Impact Resistant Tungsten Carbide (works with mechanical fasteners)
V-Tip: Long Life Tungsten Carbide (for vulcanized belts only)
- Available for Belt Widths **SST XD Tensioner:** 450 to 2400 mm (18 to 96"). Other sizes available upon request.
MST Tensioner: 450 to 1800mm (18 to 72"). Other sizes available upon request
ATV Tensioner: 600 to 2400mm (24 to 96"). Other sizes available upon request.
- CEMA Cleaner Rating Class 5

Section 8 - Specs and CAD Drawings

8.2 CAD Drawing - MHS HD - SST XD

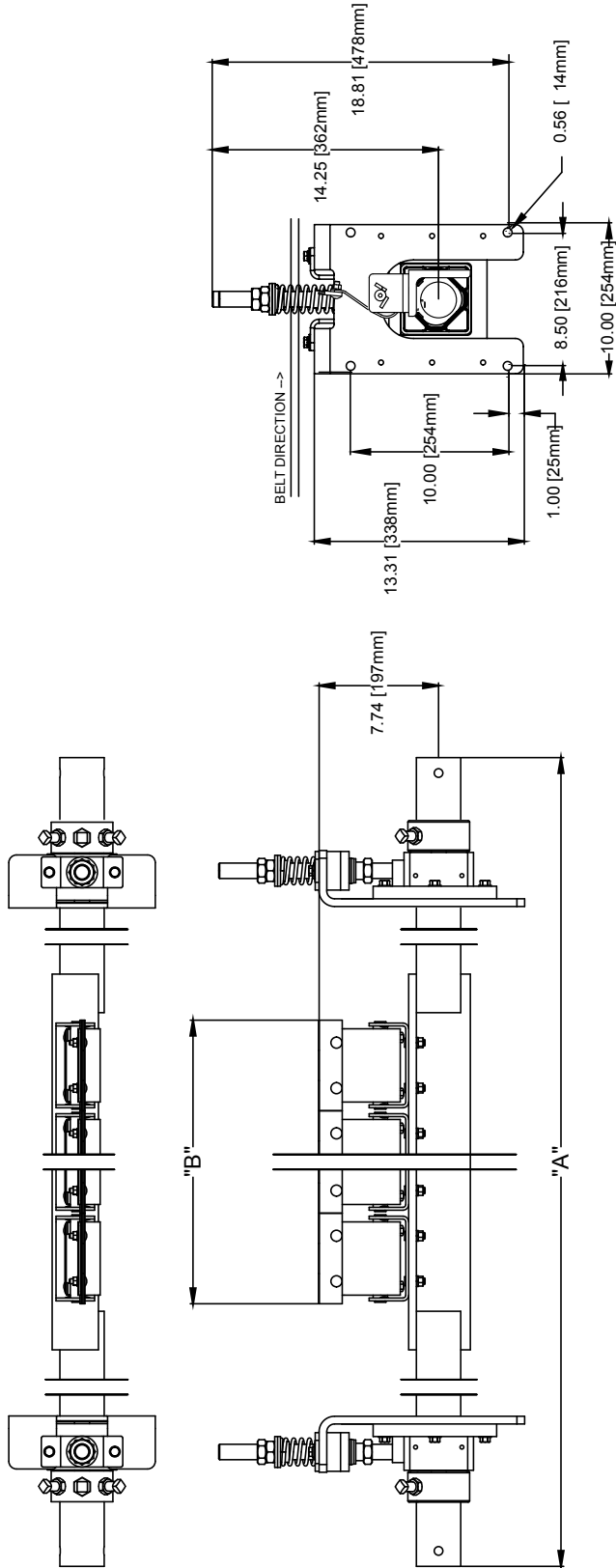

PART NO.	75910	75911	75912	75913
BELT WIDTH	24" [600mm]	30" [750mm]	36" [900mm]	42" [1050mm]
LENGTH "A"	66.48" [1689mm]	72.36" [1838mm]	78.24" [1987mm]	84.12" [2137mm]
LENGTH "B"	23-5/8" [600mm]	29-1/2" [751mm]	35-1/2" [902mm]	41-3/8" [1051mm]
NO. OF BLADES	4	5	6	7

PART NO.	75914	75915	75916	75917	76803
BELT WIDTH	48" [1219mm]	54" [1372mm]	60" [1524mm]	72" [1829mm]	84" [2134mm]
LENGTH "A"	90" [2286mm]	95.88" [2435mm]	101.76" [2585mm]	113.52" [2883mm]	125.28" [3182mm]

PART NO.	75914	75915	75916	75917	76803
BELT WIDTH	48" [1219mm]	54" [1372mm]	60" [1524mm]	72" [1829mm]	84" [2134mm]
LENGTH "A"	90" [2286mm]	95.88" [2435mm]	101.76" [2585mm]	113.52" [2882mm]	125.28" [3182mm]
LENGTH "B"	47-1/4" [1200mm]	53-1/4" [1353mm]	59-1/8" [1500mm]	70-7/8" [1800mm]	82-5/8" [2100mm]
NO. OF BLADES	8	9	10	12	14
					16

Section 8 - Specs and CAD Drawings

8.3 CAD Drawing - MHS HD - MST

BELT WIDTH	MILD STEEL		STAINLESS STEEL	
	ORDER NO.	ITEM CODE	ORDER NO.	ITEM CODE
600	MHS-600-MST	64020	MHS-600-MST-S/S	64030
750	MHS-750-MST	64021	MHS-750-MST-S/S	64031
900	MHS-900-MST	64022	MHS-900-MST-S/S	64032
1050	MHS-1050-MST	64023	MHS-1050-MST-S/S	64033
1200	MHS-1200-MST	64024	MHS-1200-MST-S/S	64034
1350	MHS-1350-MST	64025	MHS-1350-MST-S/S	64035
1500	MHS-1500-MST	64026	MHS-1500-MST-S/S	64036
1800	MHS-1800-MST	64027	MHS-1800-MST-S/S	64037
2100	MHS-2100-MST	64028	MHS-2100-MST-S/S	64038
2400	MHS-2400-MST	64029	MHS-2400-MST-S/S	64039

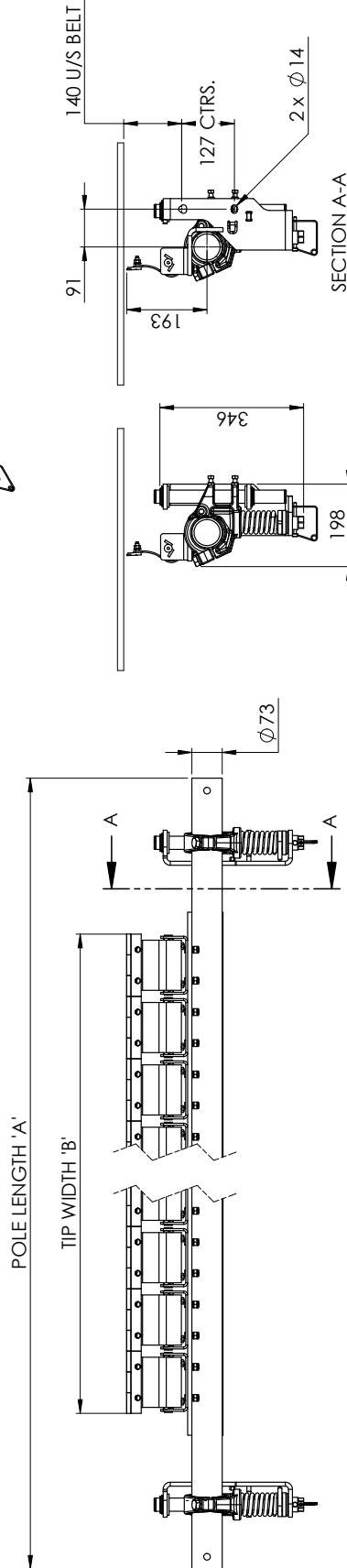
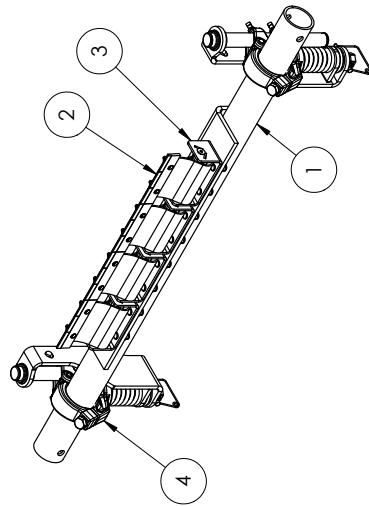

Section 8 - Specs and CAD Drawings

8.4 CAD Drawing - MHS HD - ATV

BELT WIDTH	STAINLESS STEEL		PRESSURE kPa (psi)
	ORDER NO.	ITEM CODE	
600	MHS-600-ATV-S/S	CONTACT FLEXCO	270 (39)
750	MHS-750-ATV-S/S	CONTACT FLEXCO	284 (41)
900	MHS-900-ATV-S/S	CONTACT FLEXCO	298 (43)
1050	MHS-1050-ATV-S/S	CONTACT FLEXCO	311 (45)
1200	MHS-1200-ATV-S/S	CONTACT FLEXCO	325 (47)
1350	MHS-1350-ATV-S/S	CONTACT FLEXCO	339 (49)
1500	MHS-1500-ATV-S/S	CONTACT FLEXCO	353 (51)
1800	MHS-1800-ATV-S/S	CONTACT FLEXCO	380 (55)
2100	MHS-2100-ATV-S/S	CONTACT FLEXCO	409 (59)
2400	MHS-2400-ATV-S/S	CONTACT FLEXCO	438 (63)

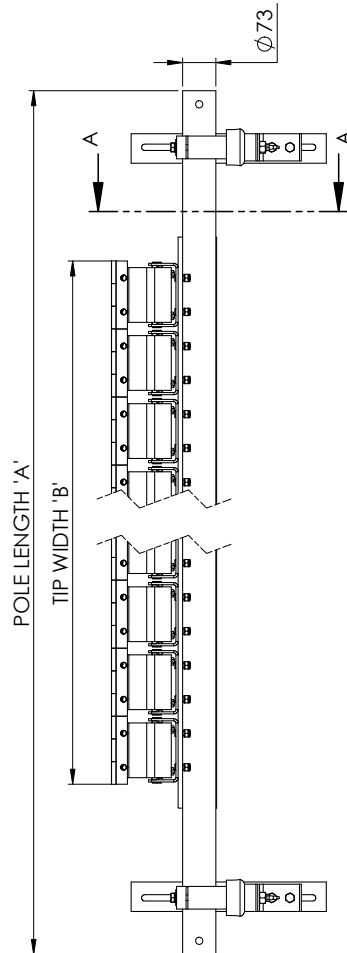
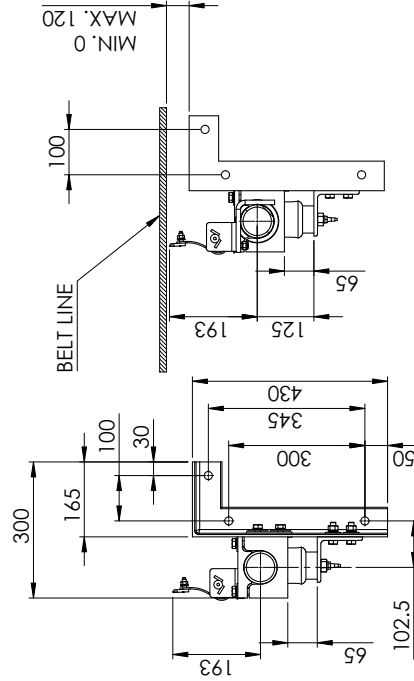
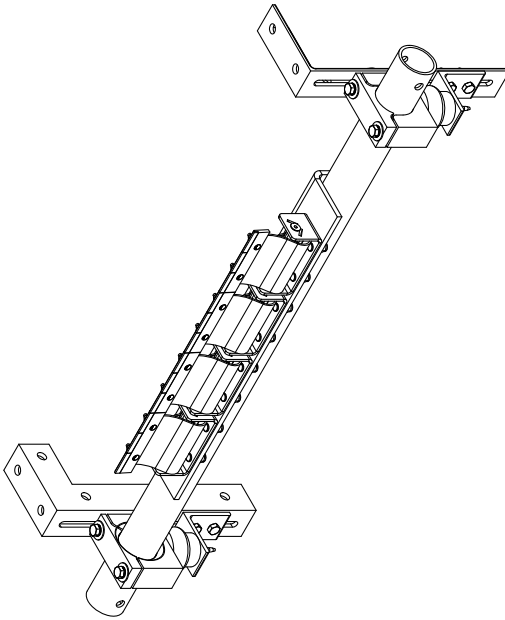

Section 9 - Replacement Parts

9.1 Replacement Parts List - MHS HD

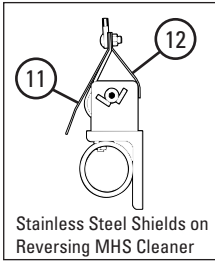

Stainless Steel Shields on Reversing MHS Cleaner

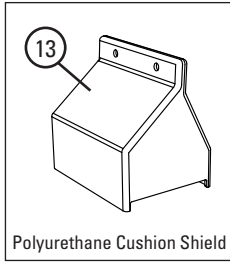

Polyurethane Cushion Shield

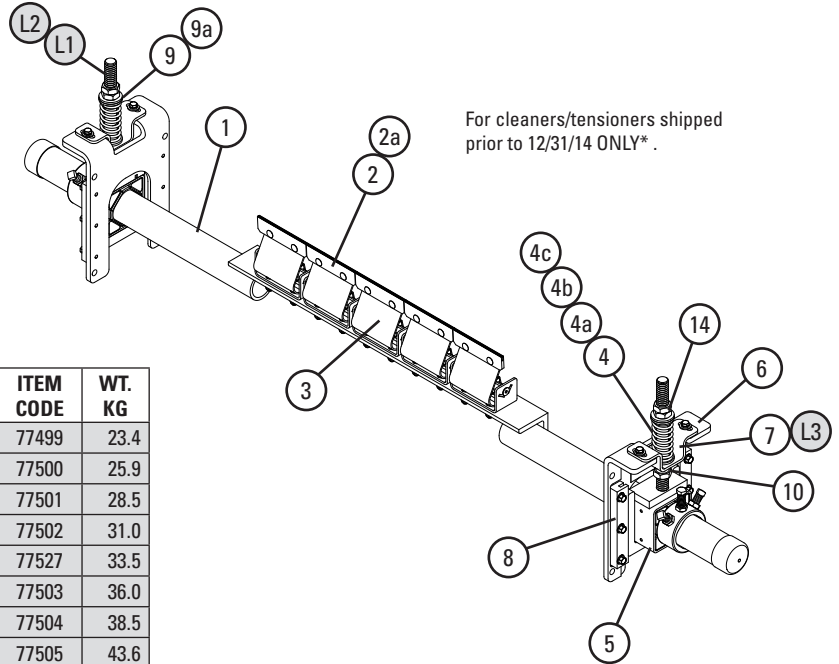

Replacement Parts

REF	DESCRIPTION	ORDERING NUMBER	ITEM CODE	WT. KG
	600 mm (24") Pole	MHS-P600	77499	23.4
	750 mm (30") Pole	MHS-P750	77500	25.9
	900 mm (36") Pole	MHS-P900	77501	28.5
	1050 mm (42") Pole	MHS-P1050	77502	31.0
	1200 mm (48") Pole	MHS-P1200	77527	33.5
	1350 mm (54") Pole	MHS-P1350	77503	36.0
	1500 mm (60") Pole	MHS-P1500	77504	38.5
	1800 mm (72") Pole	MHS-P1800	77505	43.6
	2100 mm (84") Pole	MHS-P2100	77506	50.8
	2400 mm (96") Pole	MHS-P2400	77507	58.1
2	C-Tip*	ICT6	74535	0.3
2a	V-Tip* (for vulcanized belts only)	RSA150	73628	0.6
3	PowerFlex™ Cushion* (complete)	PFC	75927	1.9
4	Tension Spring - White (1 ea.) for belts 450–750 mm (18–30")	STS-W	75846	0.2
4a	Tension Spring - Silver (1 ea.) for belts 900–1200 mm (36–48")	STS-S	75843	0.4
4b	Tension Spring - Black (1 ea.) for belts 1350–2100 mm (54–84")	STS-B	75844	0.5
4c	Tension Spring - Gold (1 ea.) for belts 2400 mm (96")	STS-G	78142	0.6
5	HD Torsion Pole Mount* (1 ea.) (includes HD adjusting rod, nuts & sleeve) (See 9 & 9a for bushings)	SSTHDP	77868	6.8
6	SST XD Mounting Base Kit* (includes 1 mtg base, 2 slide guides, top hat bracket & bottom bushing)	SSTXDMK	91412	4.6
7	SST Hat Bracket (pair)	SSTHB	79582	1.4
8	Slide Guide Kit* (incl. 2 slide guides)	STGK2	77867	0.5
9	SST Bushing Kit - White/Silver (includes 2 bushings)	SSTBK-W	76636	0.0
9a	SST Bushing Kit - Black/Gold (includes 2 bushings)	SSTBK-B	76637	0.0
10	SST Lower Bushing Kit (pair)	SSTLBK	79493	0.1
11	P Stainless Steel Shield	PSSS	74773	0.2
12	PowerFlex™ Reverse Shield	PFRS	76622	0.2
13	Polyurethane Cushion Shield	UPFCC	79320	0.1
14	Jam Nut Kit SST	JNK-C	79893	0.1
–	SST XD Spring Tensioner* - White (includes 2 each items 4, 5, 6, & 9) for belts 450–750 mm (18–30")	SSTXD-W	91408	27.5
–	SST XD Spring Tensioner* - Silver (includes 2 each items 4a, 5, 6, & 9a) for belts 900–1200 mm (36–48")	SSTXD-S	91409	27.8
–	SST XD Spring Tensioner* - Black (includes 2 each items 4b, 5, 6, & 9a) for belts 1350–2100 mm (54–84")	SSTXD-B	91410	28.1
–	SST XD Spring Tensioner* - Gold (includes 2 each items 4c, 5, 6, & 9a) for belts 2400 mm (96")	SSTXD-G	91411	28.4

*Hardware Included
Lead time: 1 working day

Legacy Replacement Parts for Tensioners shipped prior to Dec. 31, 2014*

L1	Adjusting Rod Kit (includes 1 rod, 2 nuts, 1 bushing, 1 washer) for belts 600–1500 mm (24–60")	STAK	75847	1.3
L2	HD Adjusting Rod Kit (includes 1 rod, 2 nuts, 1 HD bushing, 1 washer) for belts 1800–2100 mm (72–84")	STAKHD	75892	1.4
L3	Legacy SST Hat Channel Kit	SSTHK	79070	0.7
–	SAT2 Adjusting Rod Kit (2 ea.)	SAT2AK	78733	2.3
–	SST Tensioner Bushing Update Kit (includes 2 lower bushings, 2 sleeves, 2 nuts)	SST-BUK	76943	0.1

*Verify if legacy parts are needed by looking at threaded rod. If it has standard threads, use legacy parts. If it has flat/acme threads, choose from regular replacement parts.



Standard thread profile



Acme/trapezoidal thread profile

Spring Tensioner Selection Chart

CLEANER SIZE	91408 SSTXD-W	91409 SSTXD-S	91410 SSTXD-B	91411 SSTXD-G
MHS 450–750 mm (18–30")	X			
MHS 900–1200 mm (36–48")		X		
MHS 1350–2100 mm (54–84")			X	
MHS 2400 mm (96")				X

Shaded items are made to order.
Lead time: 3 weeks

Section 9 - Replacement Parts

9.2 Replacement Parts List - MST and ATV Tensioners

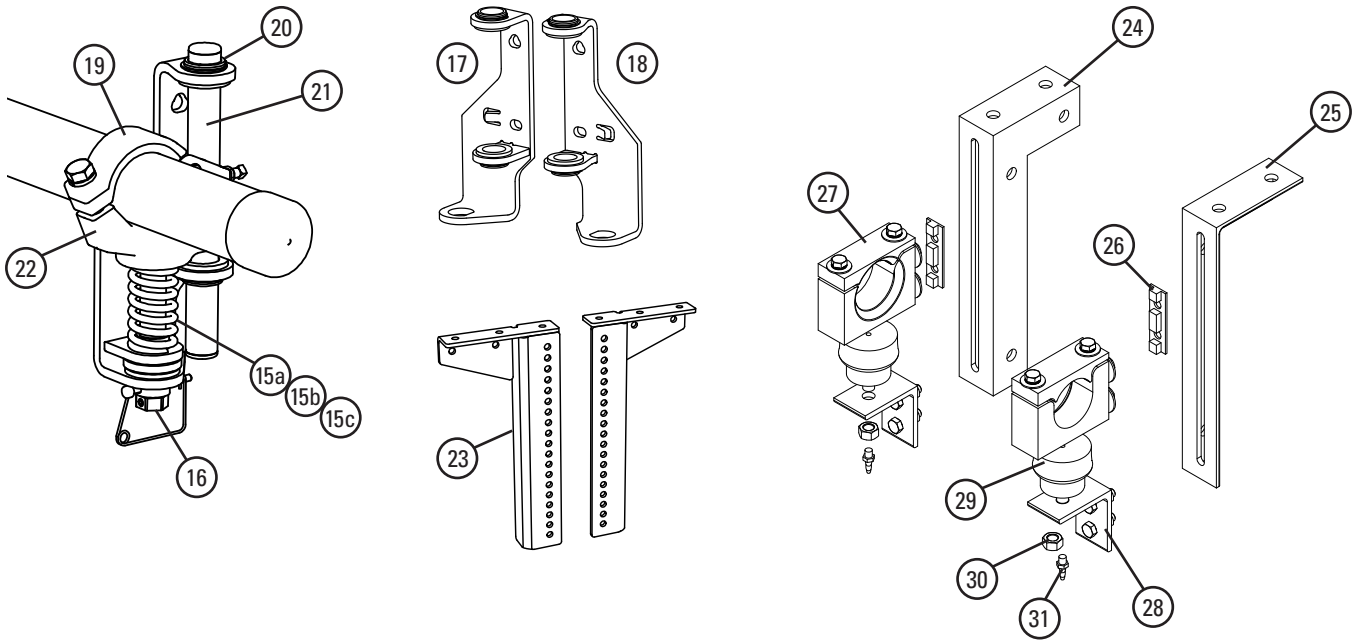

Replacement Parts - MST Tensioner

REF	DESCRIPTION	ORDERING NUMBER	ITEM CODE	WT. KG
15a	Tension Spring - White (1 ea.) for belts 450-750 mm (18-30')	STS-W	75846	0.2
15b	Tension Spring - Silver (1 ea.) for belts 900-1350 mm (36-54')	STS-S	75843	0.4
15c	Tension Spring - Black (1 ea.) for belts 1500-1800 mm (60-72')	STS-B	75844	0.5
16	MST Adjusting Mechanism	MSTAM	79435	1.3
17	MST Mounting Bracket LH (incl. bushings)	MST-MBL	79436	2.6
18	MST Mounting Bracket RH (incl. bushings)	MST-MBR	79437	2.6
19	MST HD Clamp*	MSTCHD	79439	1.1
20	MST Bushing Kit (incl. 4 bushings)	MSTBK	79440	0.1
21	MST Guide Pole	MSTGT	79441	0.7
22	MST HD Pole Mount*	MSTPMHD	79451	3.3
23	MST Drop Brackets (2)	MSTDB	79434	12.6
-	MST HD Tensioner w/White Spring (incl. 1 ea. items 17 & 18; 2 ea. items 15a, 16, 19, 21, 22)	MSTHD-W	79431	16.7
-	MST HD Tensioner w/Silver Spring (incl. 1 ea. items 17 & 18; 2 ea. items 15b, 16, 19, 21, 22)	MSTHD-S	79432	17.0
-	MST HD Tensioner w/Black Spring (incl. 1 ea. items 17 & 18; 2 ea. items 15c, 16, 19, 21, 22)	MSTHD-B	79433	17.3

*Hardware included
Lead time: 1 working day

ATV Replacement Parts

REF	DESCRIPTION	ORDERING NUMBER	ITEM CODE	WT. KG.
24	Mounting Bracket LH	PMBL-S/S	75518	3.8
25	Mounting Bracket RH	PMBR-S/S	75521	3.8
26	Air Tensioner Slider	ATV-SLIDE	62425	0.2
27	Air Tension Cradle Blocks 73 mm Kit	ATV-MOUNT	63073	2.4
28	Air Tension Adjusting Angle	ATV-ANGLE	62426	1.0
29	Air Bag	ATV-BAG	62036	0.2
30	5/8" Hex Nut S/S	-	G1211	0.1
31	Air Line Adaptor	ATV-NIP	62037	0.1

Shaded items are made to order. Lead time 3 weeks.

Shaded items are made to order.
Lead time: 3 weeks

MST Spring Tensioner Selection Chart

CLEANER SIZE	79431 MSTHD-W	79432 MSTHD-S	79433 MSTHD-B
MHS 450-750 mm (18-30")	X		
MHS 900-1350 mm (36-54")		X	
MHS 1500-1800 mm (60-72")			X

Section 9 - Replacement Parts

9.3 Replacement Parts List - MHS -Stainless Steel

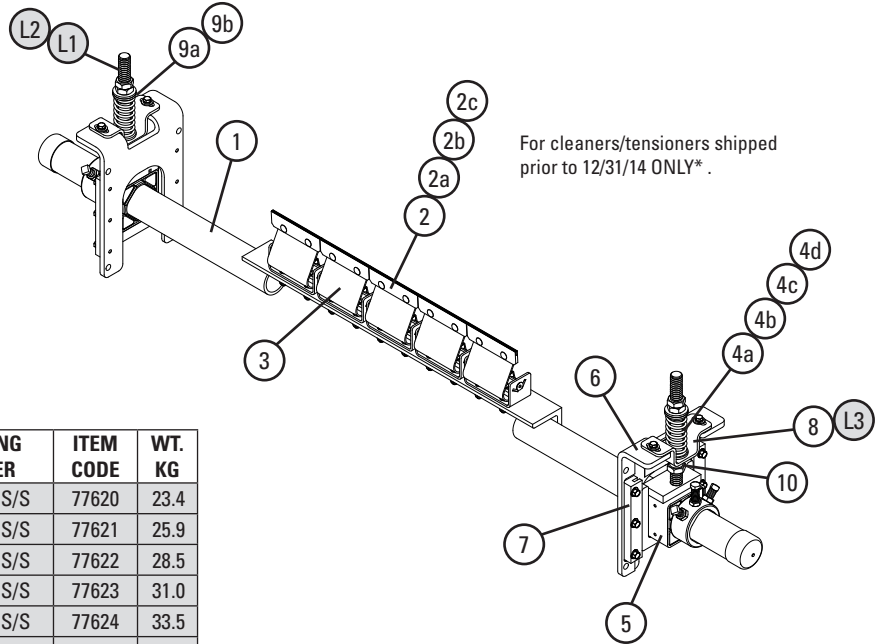
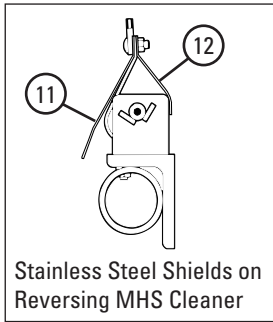

For cleaners/tensioners shipped prior to 12/31/14 ONLY*.

Replacement Parts

REF	DESCRIPTION	ORDERING NUMBER	ITEM CODE	WT. KG
1	600mm (24") SS Pole	MHSP24-S/S	77620	23.4
	750mm (30") SS Pole	MHSP30-S/S	77621	25.9
	900mm (36") SS Pole	MHSP36-S/S	77622	28.5
	1050mm (42") SS Pole	MHSP42-S/S	77623	31.0
	1200mm (48") SS Pole	MHSP48-S/S	77624	33.5
	1350mm (54") SS Pole	MHSP54-S/S	77625	36.0
	1500mm (60") SS Pole	MHSP60-S/S	77626	38.5
	1800mm (72") SS Pole	MHSP72-S/S	77627	43.6
	2100mm (84") SS Pole	MHSP84-S/S	77628	50.8
2400mm (96") SS Pole	MHSP96-S/S	79053	58.1	
2	C-Tip*	ICT6	74535	0.3
2a	SS C-Tip	ICT6-S/S	78700	0.3
2b	V-Tip* (for vulcanized belts only)	RSA150	73628	0.6
2c	S/S V-Tip* (for vulcanized belts only)	RVT6-S/S	76205	0.6
3	PowerFlex Cushion* SS (complete)	PFC-SS	76560	1.9
4a	Tension Spring-White (1 ea.) for belts 450-750mm (18-30")	STS-W-S/S	77630	0.2
4b	Tension Spring-Silver (1 ea.) for belts 900-1200mm (36-48")	STS-S-S/S	77631	0.4
4c	Tension Spring-Black (1 ea.) for belts 1350-2100mm (54-84")	STS-B-S/S	77632	0.5
4d	Tension Spring-Gold (1 ea.) for belts 2400mm (96")	STS-G-S/S	79057	0.6
5	SS HD Torsion Mounting Kit* (1 ea.) (includes adjusting rod, 3 nuts & sleeve) (See 9 & 9a for bushings)	STHDPM2-S/S	77633	6.8
6	SS Mounting Base Kit* (includes 1 mounting base, 2 slide guides, top hat bracket & bottom bushing)	STHDMK2-S/S	77634	4.6
7	SS Base Mounting Kit* (includes 2 slide guides)	STGK2-S/S	77635	-
8	SST Hat Bracket S/S (pair)	SSTHB-S/S	79586	1.4
9a	SST Bushing Kit-White/Silver (includes 2 bushings)	SSTBK-W	76636	0.0
9b	SST Bushing Kit-Black/Gold (includes 2 bushings)	SSTBK-B	76637	0.0
10	SST Lower Bushing Kit (pair)	SSTLBK	79493	0.1
11	P Stainless Steel Shield	PSSS	74773	0.2
12	PowerFlex™ Reverse Shield	PFRS	76622	0.2
-	SS Spring Tensioner*-White (includes 2 each items 4, 5, 6 & 9) for belts 450-750mm (18-30")	SST2HD-W-S/S	77637	27.5
-	SS Spring Tensioner*-Silver (includes 2 each items 4a, 5, 6 & 9) for belts 900-1200mm (36-48")	SST2HD-S-S/S	77638	27.8
-	SS Spring Tensioner*-Black (includes 2 each items 4b, 5, 6 & 9a) for belts 1350-2100mm (54-84")	SST2HD-B-S/S	77639	28.1
-	SS Spring Tensioner*-Gold (includes 2 each items 4c, 5, 6 & 9a) for belts 2400mm (96")	SST2HD-G-S/S	79042	28.4

*Hardware Included
Lead time: 1 working day

Legacy Replacement Parts for Tensioners shipped prior to changeover Dec. 31, 2014*

L1	Adjusting Rod Kit* (includes 1 rod, 2 nuts, 1 bushing, 1 washer) for belts 450-1500mm (18-60")	STAK	75847	1.3
L2	HD Adjusting Rod Kit* (includes 1 rod, 2 nuts, 1 HD bushing, 1 washer) for belts 1800-2400mm (72-96")	STAKHD	75892	1.4
L3	SST Hat Channel Kit S/S	SSTHK-S/S	79071	0.7
-	SS Bushing Update Kit (includes 2 ea. lower bushings, sleeves, nuts)	SST-BUK-S/S	77636	0.1

*Verify if legacy parts are needed by looking at threaded rod. If it has standard threads, use legacy parts. If it has flat/acme threads, choose from regular replacement parts.



Standard thread profile



Acme/trapezoidal thread profile

Spring Tensioner Selection Chart

CLEANER SIZE	77637 SSTDH-W-S/S	77638 SSTDH-S-S/S	77639 SSTDH-B-S/S	79042 SSTDH-G-S/S
MHS S/S 450-750mm (18-30")	X			
MHS S/S 900-1200mm (36-48")		X		
MHS S/S 1350-2100mm (54-84")			X	
MHS S/S 2400 mm (96")				X

Shaded items are made to order.
Lead time: 3 weeks

Section 10 - Other Flexco Conveyor Products

Flexco provides many conveyor products that help your conveyors to run more efficiently and safely. These components solve typical conveyor problems and improve productivity. Here is a quick overview on just a few of them:

MMP Precleaner



- Extra cleaning power right on the head pulley
- A 250 mm (10") TuffShear™ blade provides increased blade tension on the belt to peel off abrasive materials
- The unique Visual Tension Check™ ensures optimal blade tensioning and quick, accurate retensioning
- Easy to install and simple to service

DRX Impact Beds



- Exclusive Velocity Reduction Technology™ in order to better protect the belt
- Slide-Out Service™ gives direct access to all impact bars for change-out
- Impact bar supports for longer bar life
- 4 models to custom fit to the application

MDWS DryWipe Secondary Cleaner



- Wipes the belt dry as final cleaner in system
- Automatic blade tensioning to the belt
- Easy, visual blade tension check
- Simple, one-pin blade replacement

PT Max™ Belt Trainer



- Patented “pivot & tilt” design for superior training action
- Dual sensor rollers on each side to minimize belt damage
- Pivot point guaranteed not to freeze up
- Available for topside and return side belts

Flexco Specialty Belt Cleaners



- “Limited space” cleaners for tight conveyor applications
- High Temp cleaners for severe, high heat applications
- A rubber fingered cleaner for chevron and raised rib belts
- Multiple cleaner styles in stainless steel for corrosive applications

Belt Plows

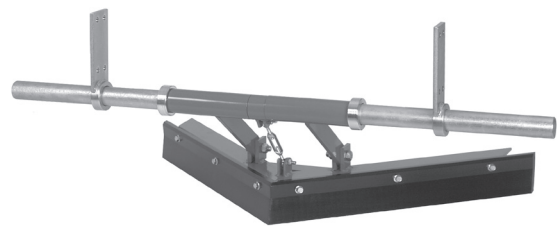

- A belt cleaner for the tail pulley
- Exclusive blade design quickly spirals debris off the belt
- Economical and easy to service
- Available in vee or diagonal models

Visit www.flexco.com for other Flexco locations and products, or to find an authorised distributor.

©2023 Flexible Steel Lacing Company. 01-22-24. X3032

