



Pneumatic Single Rivet Driver

Ordering Number: pneudrive1



Safety, Operation, and Maintenance Manual

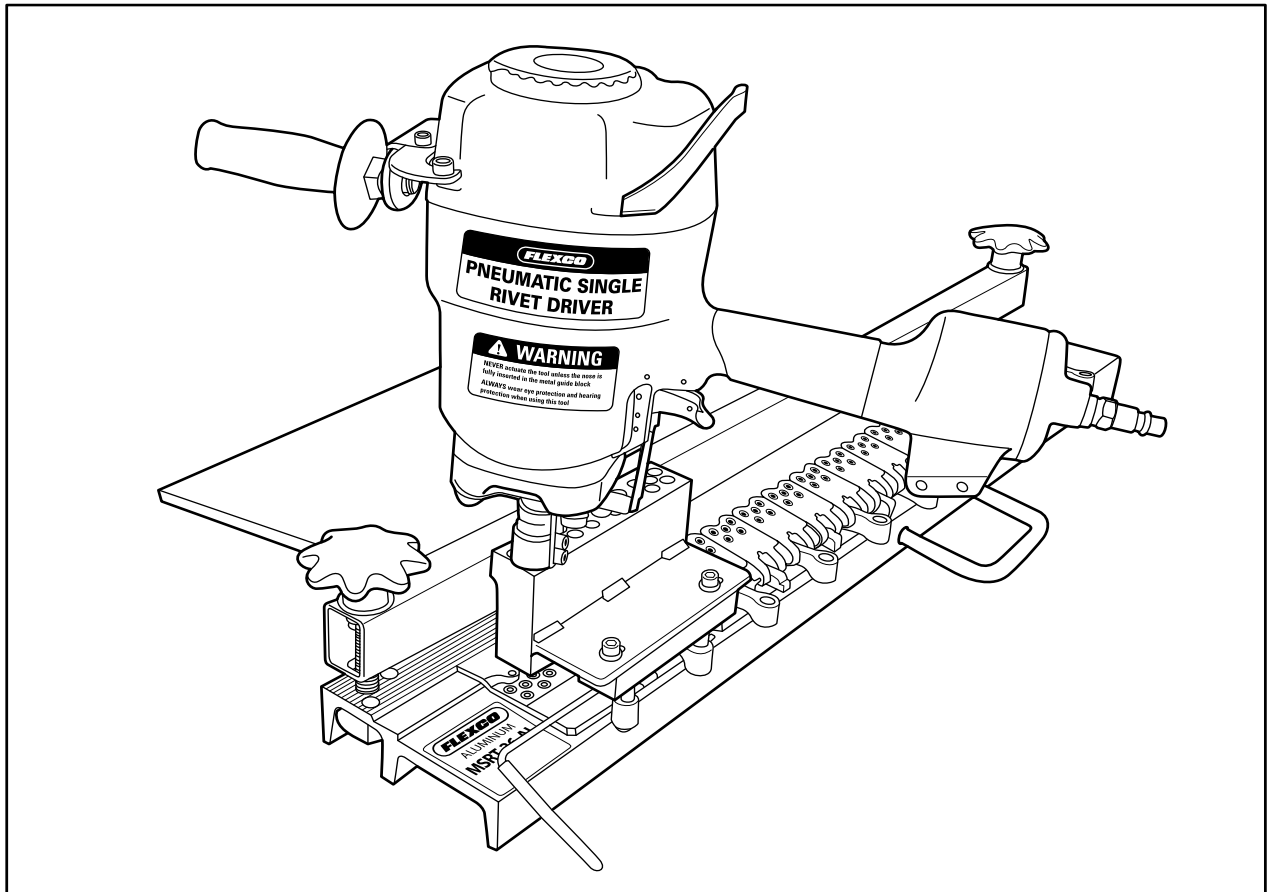

WARNING

Improper use of this tool can result in serious bodily injury! This manual contains important information about product function and safety. Please read and understand this manual BEFORE operating the tool. Please keep this manual available for other users and owners before they use the tool. This manual should be stored in a safe place.

Table of Contents

Main Components.....pg. 3

System Components pgs. 4-5

Introduction.....pg. 6

Tool Specifications.....pg. 6

General Safety Rules..... pgs. 7-10

Operational Instructions pgs. 11-12

Set-Up Procedurepg. 13

Fastener Installation..... pgs. 14-16

Maintenance Instructionspg. 17

Trouble Shooting Guidepg. 18

Exploding Parts Diagrampg. 19

Limited Warranty

Flexco warrants to the original purchaser that this product is free from defects in material and workmanship, and agrees to repair or replace, at Flexco's option, any defective product within 1 year from the date of purchase. This warranty is not transferable. It only covers damage resulting from defects in material or workmanship, and it does not cover conditions or malfunctions resulting from normal wear, neglect, abuse, accident or repairs attempted or made by other than our regional repair centre or authorized warranty service centre. Driver blades, drive rods, bumpers, and o-rings are considered normally wearing parts.

To obtain warranty service, return the product at your expense together with proof of purchase to Flexco or a Flexco authorized distributor.

Pneumatic Single Rivet Driver

Main Components

1. Handle
2. Safety
3. Trigger
4. Male plug 3/8" NPT
5. Warning Labels (U8294)
6. Return Spring

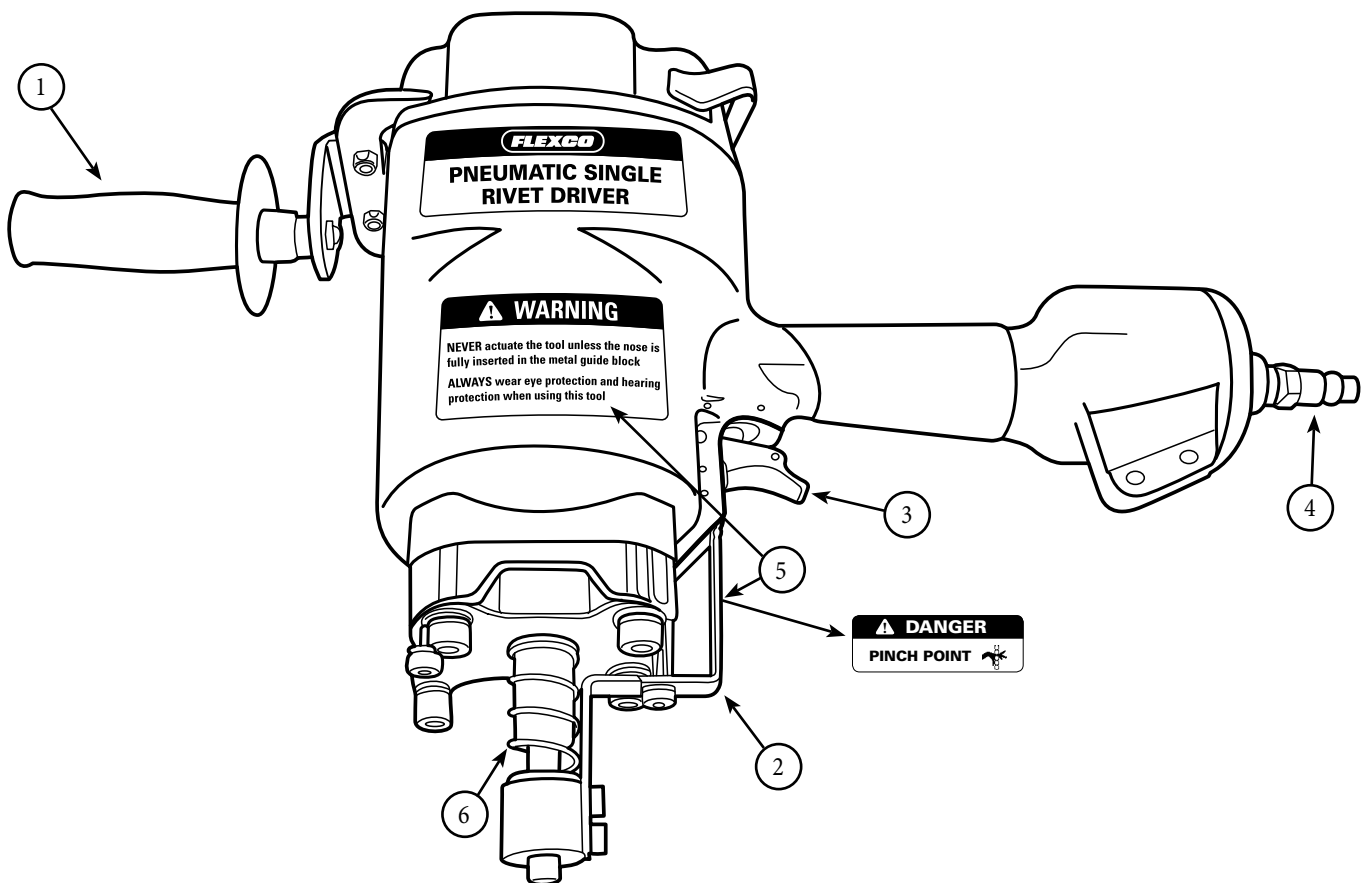

Pneumatic Single Rivet Driver

System Components

Pneudrive 1

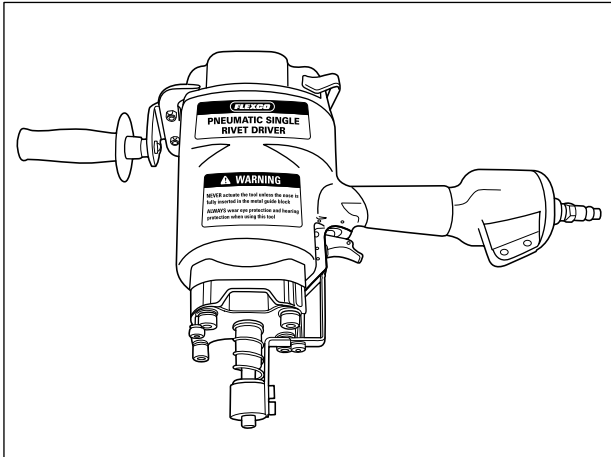

Pneumatic Single Rivet Driver

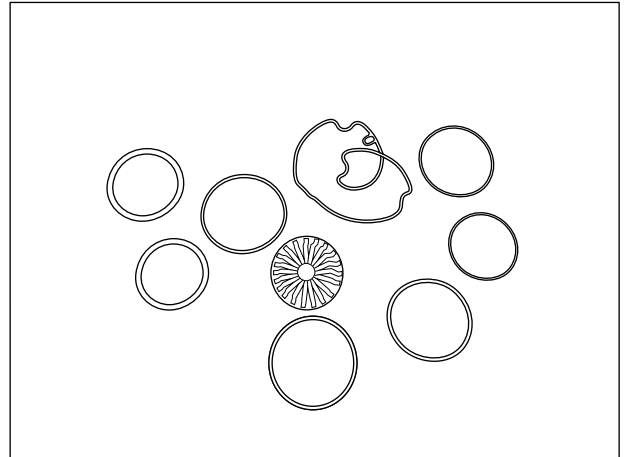

O-Ring

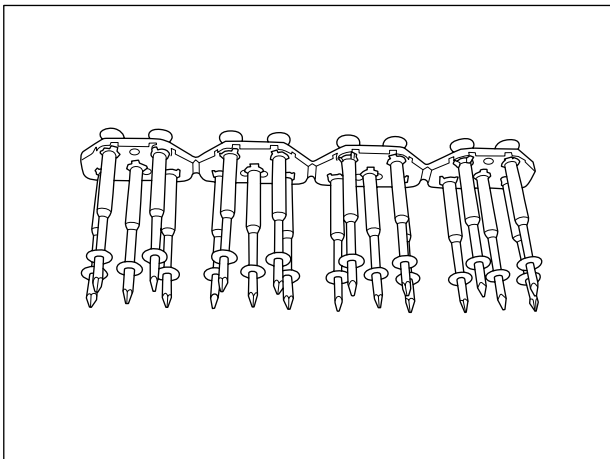

Rivets with washers

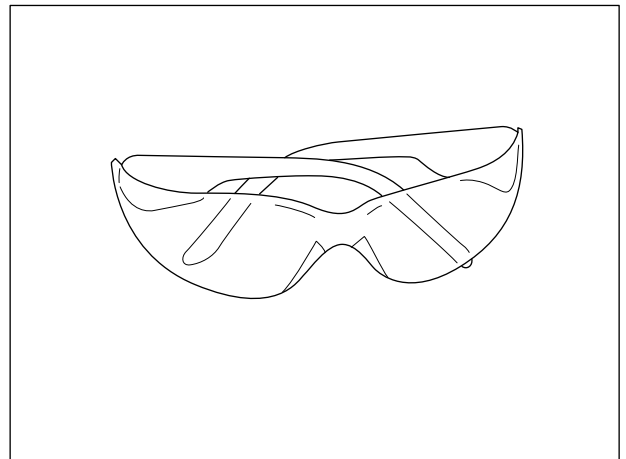

Safety glasses

Pneumatic Single Rivet Driver

System Components

Pneudrive 1 (Standard Equipment)

Regulator kit

1. Air pressure cap
2. Oil flow cap
3. Parker No. 24-5 BP
couples 3/8": Push-lok hose
4. Oiler
5. Filter
6. Parker No. H2E 3/8"
male nipple

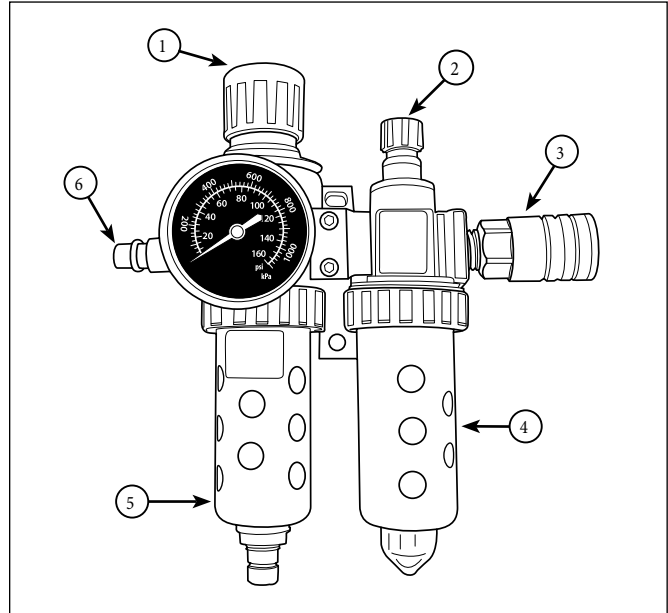

Fastening System

1. Installation tool
2. Steel guide block
3. Mechanical belt fastener

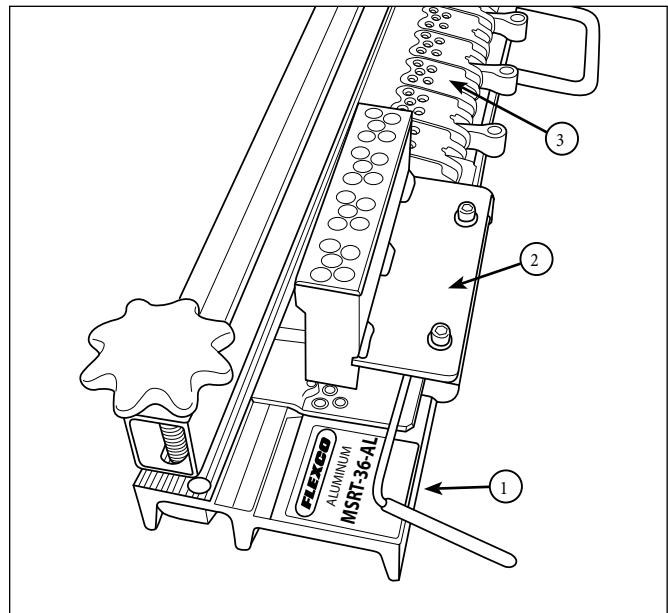

Pneumatic Single Rivet Driver

Introduction

Role of Rivet Driver

The Pneumatic Single Rivet Driver is designed to be used with Flexco® SR™ Rivet Hinged Fasteners as well as Flexco® BR™ Rivet Solid Plate Fastener. This tool also requires the use of steel guide blocks, the 5 rivet pattern SR: item code 42000 (35RD-GB5-4) or the 8 rivet pattern SR: item code 41998 (35RD-GB8-4). In addition, the use of Rapid Loader™ rivets with washers is required.

Precision Built

FLEXCO tools are precision-built tools designed for precise, high volume rivet driving. These tools will deliver efficient, dependable service when used correctly and with care. As with any fine power tool, for best performance, the manufacturer's instructions must be followed. Please study this manual before operating the tool and understand the safety warnings and cautions. The instructions on installation, operation, and maintenance should be read carefully, and the manual kept for reference.

Tool Specifications

Metric Screws and Nuts

Tool Air Fitting

Tool uses a 3/8" N.P.T. male plug. The airflow diameter should be .275" (7 mm) or larger. The fitting must be capable of discharging tool air pressure when disconnected from the air supply.

Operating Pressure

45 to 95 p.s.i./3-6.5 bar

Select the operating pressure within this range for best fastener performance.

DO NOT EXCEED THIS RECOMMENDED OPERATING PRESSURE.

Air Consumption

Tool requires 6.9 cubic feet minimum per minute (194 liters per minute) of free air to operate at the rate of 50 nails per minute, at 80 p.s.i. (5.6 kg/cm²).

Weight

Total package – 27 lbs/12.25 kg

Tool only – 12.75 lbs/5.55 kg

Pneumatic Single Rivet Driver

General Safety Rules

—Save These Instructions—

Signal words

“DANGER” indicates an imminently hazardous situation which, if not avoided, will result in death or serious injury. The signal word is limited to the most extreme situations.

“WARNING” indicates a potentially hazardous situation which, if not avoided, could result in death or serious injury.

“CAUTION” indicates a potentially hazardous situation which, if not avoided, may result in minor or moderate injury. It may also be used to alert against unsafe practices.

International Safety Symbol



This international safety symbol is used to identify and call attention to specific safety matters.

Safety Information

To Avoid Severe Personal Injury or Property Damage, read carefully and understand the following Safety Precautions.

1. WORK AREA SAFETY

DANGER

Do not allow bystander, visitor, or children in work area during tool operation.

CAUTION

Keep work area clean and well lit. Clutter and dark areas invite accidents.

WARNING

Store tools outside the reach of children and untrained persons. Tools are dangerous in the hands of unskilled users.

2. PERSONAL PROTECTIVE EQUIPMENT

WARNING

EYE PROTECTION which conforms to ANSI specifications and provides protection against flying particles both from the FRONT and SIDE should ALWAYS be worn by the operator and others in the work area when connecting to air supply, loading, operating or servicing this tool. Eye protection is required to guard against flying fasteners and debris, which could cause severe eye injury.

The employer and/or user must ensure that proper eye protection is worn and provide both frontal and side protection. **NOTE:** Non-side shielded spectacles and face shields alone do not provide adequate protection.

CAUTION

HEARING PROTECTION will be required in some environments. For example, the working area may include exposure to noise level which can lead to hearing damage. The employer and user must ensure that any necessary hearing protection is provided and used by the operator and others in the work area.

FLEXCO

Pneumatic Single Rivet Driver

General Safety Rules

⚠ CAUTION

HEAD PROTECTION – Some environments will require the use of head protection equipment.

⚠ CAUTION

FOOT PROTECTION – Safety footwear should always be worn. Operators must be protected against falling tools, stepping on nails and rivets, and slippery conditions.

3. PERSONAL SAFETY

⚠ WARNING

Stay alert, watch what you are doing and use common sense when operating a power tool. Do not use tool while tired or under the influence of drugs, alcohol, or medication. A moment of inattention while operating power tools may result in serious personal injury.

⚠ WARNING

Do not overreach. Keep proper footing and balance at all times to enable better control of the tool in unexpected situations.

⚠ WARNING

Never alter or remove safety devices.

⚠ WARNING

Do not pull trigger or depress safety arm while connected to the air supply as the tool may cycle, possibly causing injury.

⚠ WARNING

Do not use in explosive environments.

⚠ WARNING

Always disconnect air supply: 1.) Before making adjustments; 2.) When servicing the tool; 3.) When clearing a jam; 4.) When tool is not in use; 5.) When moving to a different work area, as accidental actuation may occur, possibly causing injury.

⚠ WARNING

1.) Never place a hand or any part of body in discharge area of tool; 2.) Never point tool at anyone; 3.) Do not pull the trigger or depress the trip as accidental actuation may occur, possibly causing injury.

⚠ WARNING

Always handle the tool with care: 1.) Never engage in horseplay; 2.) Never pull the trigger unless nose is in contact with the guide block; 3.) Keep others a safe distance from the tool while tool is in operation as accidental actuation may occur, possibly causing injury.

4. PNEUMATIC SAFETY

⚠ DANGER

AIR SUPPLY SOURCE: Use only clean regulated compressed air as a power source for this tool. **NEVER USE OXYGEN, COMBUSTIBLE GASES, OR BOTTLED GASES, AS A POWER SOURCE FOR THIS TOOL AS TOOL MAY EXPLODE.**

⚠ DANGER

FITTINGS: Install a male plug on the tool which is free flowing and which will release air pressure from the tool when disconnected from the supply source.

Pneumatic Single Rivet Driver

General Safety Rules

⚠ DANGER

HOSES: Air hoses should have a minimum of 150 p.s.i. (10.6 kg/cm²) working pressure rating or 150 percent of the maximum pressure that could be produced in the air system. The supply hose should contain a fitting that will provide “quick disconnecting” from the male plug on the tool.

⚠ DANGER

REGULATOR: A pressure regulator with an operating pressure of 0 – 125 p.s.i. (0 – 8.79 kg/cm²) is required to control the operating pressure for safe operation of this tool. Do not connect this tool to air pressure which can potentially exceed 200 p.s.i. (14 kg/cm²) as tool may fracture or burst, possibly causing injury.

⚠ CAUTION

Do not store tools in a cold weather environment to prevent frost or ice formation on the tools operating valves and mechanisms that could cause tool failure.

NOTE: Some commercial air line drying liquids are harmful to “O”-rings and seals – do not use these low temperature air dryers without checking compatibility.

⚠ WARNING

Use the Flexco pneumatic tool only for the purpose for which it was designed.

5. OPERATIONAL SAFETY

⚠ WARNING

At the beginning of each shift, check the operation of the rivet driver’s safety controls.

TOOL OPERATION CHECK:

CAUTION: Remove all fasteners from tool before performing tool operation check.

SEQUENTIAL TRIP OPERATION:

- A. Press the tool nose into guide block without touching the trigger. **THE TOOL MUST NOT CYCLE.**
- B. Hold the tool off the guide block and pull the trigger. **THE TOOL MUST NOT CYCLE.** Release the trigger. The trigger must return to the trigger stop on the frame.
- C. Pull the trigger and press the tool nose into guide block. **THE TOOL MUST NOT CYCLE.**
- D. With finger off the trigger, press the tool nose into guide block. Pull the trigger. **THE TOOL MUST CYCLE.**

⚠ WARNING

Do not use supply sources which can potentially exceed 200 p.s.i.g. as tool may burst, possibly causing injury.

⚠ WARNING

Do not drive rivets on top of other rivets.

⚠ WARNING

Always use tool with steel guide blocks.

⚠ WARNING

Never use this tool in a manner that could cause a fastener to be directed toward the user or others in the work area.



Pneumatic Single Rivet Driver

General Safety Rules

⚠️ WARNING

Do not use the tool as a hammer.

⚠️ CAUTION

Always carry the tool by the handle. Never carry the tool by the air hose.

⚠️ CAUTION

Do not alter or modify this tool from the original design or function without approval from FLEXCO.

⚠️ CAUTION

Always be aware that misuse and improper handling of this tool can cause injury to yourself and others.

⚠️ DANGER

Never clamp or tape the trigger or contact trip in an actuated position.

⚠️ WARNING

Never leave a tool unattended with the air hose attached.

⚠️ DANGER

Do not operate rivet driver unless it is engaged inside of steel guide block.

6. MAINTENANCE SAFETY

⚠️ WARNING

Check operation of the safety trip mechanism frequently. Do not use the tool if the trip is not working correctly as accidental driving of a fastener may result.

⚠️ CAUTION

Do not operate this tool if it does not contain legible WARNING LABELS.

⚠️ DANGER

Always disconnect air supply when servicing the tool or before making adjustments.

⚠️ CAUTION

REPLACEMENT PARTS: FLEXCO replacement parts are recommended. Do not use modified parts or parts which will not give equivalent performance to the original equipment.

Pneumatic Single Rivet Driver

Operational Instructions

Set-Up Information

Operating Pressure:

45 to 95 p.s.i./3-6.5 bar

Select the operating pressure within this range for best fastener performance. **DO NOT EXCEED THIS RECOMMENDED OPERATING PRESSURE.**

Air Supply-Pressure and Volume:

Air volume is as important as air pressure. The air volume supplied to the tool may be inadequate because of undersize fittings and hoses, or from the effects of dirt and water in the system. Restricted air flow will prevent the tool from receiving an adequate volume of air, even though the pressure reading is high. The results will be slow operation, misfeeds or reduced driving power. Before evaluating tool problems for these symptoms, trace the air supply from the tool to the supply source for restrictive connectors, swivel fittings, low points containing water and anything else that would prevent full volume flow of air to the tool.

Air Consumption:

Tool requires 6.9 cubic feet per minute (194 liters per minute) of free air to operate at the rate of 50 nails per minute, at 80 p.s.i. (5.6 kg/cm²).

Filter:

Dirt and water in the air supply are major causes of wear in pneumatic tools. A filter will help to get the best performance and minimum wear from the tool. The filter must have adequate flow capacity for the specific installation. The filter has to be kept clean to be effective in providing clean compressed air to the tool. Consult the manufacturer's instructions on proper maintenance of your filter. A dirty and clogged filter will cause a pressure drop which will reduce the tool's performance.

Lubrication:

Frequent, but not excessive, lubrication is required for best performance. Use Air Tool Lubricant, Mobil Velocite #10, or equivalent. Do not use detergent oil or additives as these lubricants will cause accelerated wear to the seals and bumpers in the tool, resulting in poor tool performance and frequent tool maintenance. Only a few drops of oil at a time is necessary. Too much oil will only collect inside the tool and will be noticeable in the exhaust cycle.

Cold Weather Operation:

For cold weather operation, near and below freezing, the moisture in the air line may freeze and prevent tool operation. We recommend the use of winter formula air tool lubricant or permanent antifreeze (ethylene glycol) as a cold weather lubricant. **CAUTION: Do not store tools in a cold weather environment to prevent frost or ice formation on the tools operating valves and mechanisms that could cause tool failure. NOTE: Some commercial air line drying liquids are harmful to "O"-rings and seals – do not use these low temperature air dryers without checking compatibility.**

Directional Exhaust Deflector:

The adjustable exhaust deflector can be rotated into any desired position by hand without the use of any tools.

Hoses:

Air hoses should have a minimum of 150 p.s.i. (10.6 kg/cm²) working pressure rating or 150 percent of the maximum pressure that could be produced in the air system. The supply hose should contain a fitting that will provide "quick disconnecting" from the male plug on the tool.

Supply Source:

Use only clean regulated compressed air as a power source for this tool. **NEVER USE OXYGEN, COMBUSTIBLE GASES, OR BOTTLED GASES, AS A POWER SOURCE FOR THIS TOOL AS TOOL MAY EXPLODE.**



Pneumatic Single Rivet Driver

Operational Instructions

Pneumatic Integrity:

Do not use a tool that leaks air or does not function properly. Notify your nearest FLEXCO representative if your tool continues to experience functional problems.

Operational Controls

Sequential Trip Operation:

The Sequential Trip gets its name from the “sequence” required to drive a rivet. To drive a rivet, the operator must first depress the “trip” FULLY into steel guide block and then pull the trigger. To drive a second rivet, the operator must lift the tool from the guide block, release the trigger and then repeat the above sequence. The Sequential Trip offers a positive safety advantage since it will not accidentally drive a rivet if the tool is bumped against any surface or anybody while the operator is holding the tools with the trigger pulled.

Tool Operation Check:

CAUTION: Remove all fasteners from tool before performing tool operation check.

SEQUENTIAL TRIP CHECKLIST:

- A. Press the tool nose into guide block without touching the trigger. **THE TOOL MUST NOT CYCLE.**
- B. Hold the tool off the guide block and pull the trigger. **THE TOOL MUST NOT CYCLE.** Release the trigger. The trigger must return to the trigger stop on the frame.
- C. Pull the trigger and press the tool nose into guide block. **THE TOOL MUST NOT CYCLE.**
- D. With finger off the trigger, press the tool nose into guide block. Pull the trigger. **THE TOOL MUST CYCLE.**

Pneumatic Single Rivet Driver

Set-Up Procedure

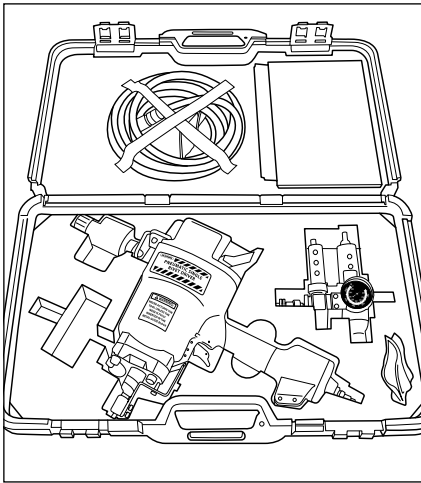

1. Pneumatic Tool Set

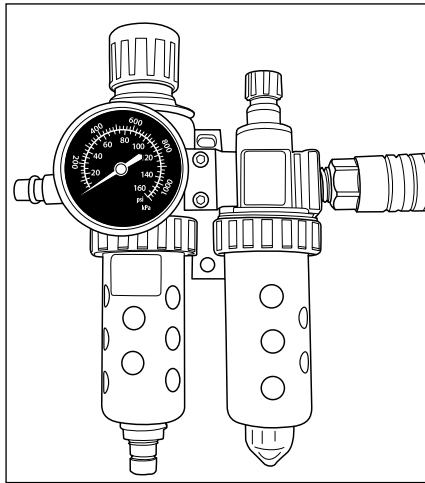

2. Mount Air Control Assembly in upright position. The air control assembly kit must remain level during tool operation. Fill oiler with Parker F442 oil or equivalent.

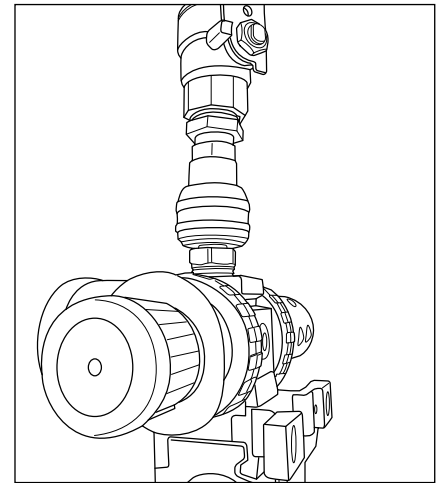

3. Connect your air compressor to the Parker No. H2E3/8" Male Nipple on the regulator kit. Use compressed air directly from an air compressor. **WARNING: Do not use any bottled gasses, including oxygen, to operate this tool. An explosion can occur.**

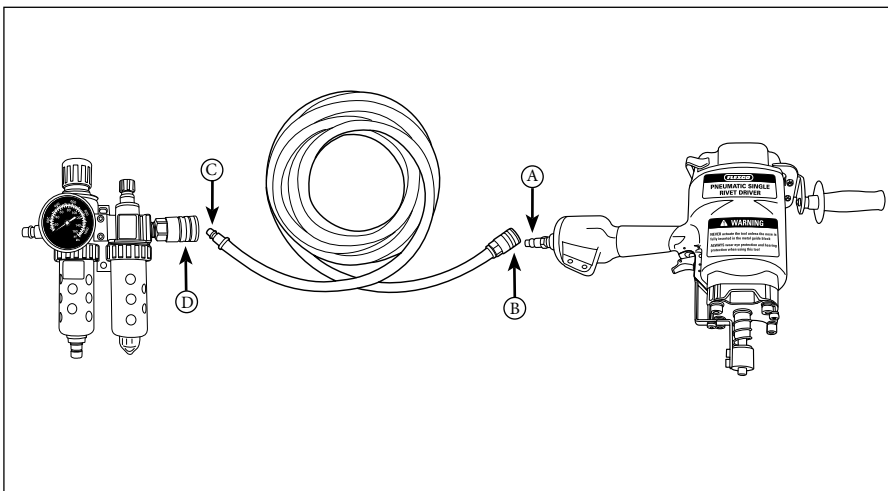

4. Continue connecting your pneumatic fittings as shown.

- a. Connect A to B
- b. Connect C to D

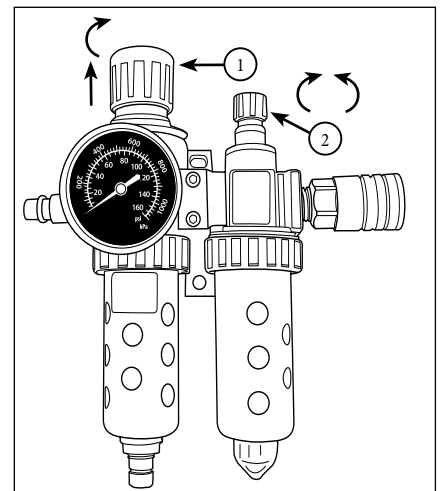

5. To adjust air pressure pull cap "1" up and turn clockwise. After desired air pressure is set, snap cap down into locked position. For optimal results operate the driver at 85-90 PSI (approximately 6 bar). Do not exceed 120 PSI (8 bar).

To adjust oil flow turn cap "2" clockwise, until tight, then turn cap counterclockwise 1 turn for proper adjustment.



Pneumatic Single Rivet Driver

Fastener Installation

NOTE: The following instructions are for SR™ installation. For steps specific to BR™ installation, please follow instructions included with BR fastener strips.

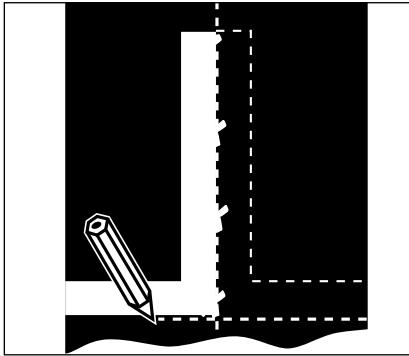

1. Square belt using centreline method. Cut belt at least 4" (100 mm) behind old splice using Flexco 900 Cutter or Electric Belt Cutter. We also recommend skiving the belt with an FSK2 Skiver.

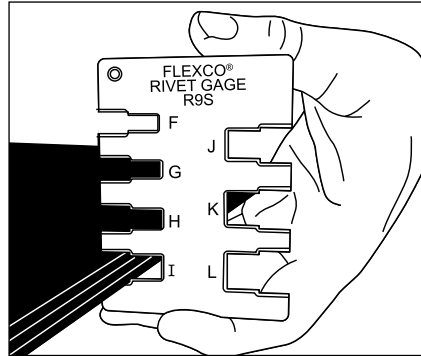

2. Measure belt thickness from cut edge using gauge or tape measure. Measure belt thickness after skiving. Use the rivet selection guide to the right to select the correct size SR/BR rivets *with washers* for your belt thickness.

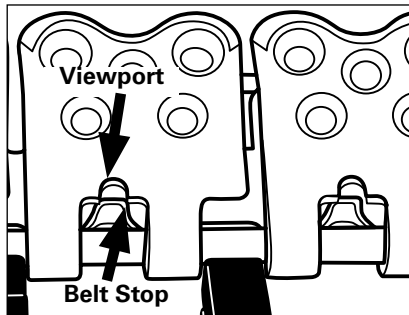

3. Insert belt end into fastener strip; centre belt in strip. Look through viewports; belt ends should be tight against belt stops. Tighten clamp bar to secure belt. Set all fastener top plates hitting one fastener at a time on the front scalloped edge portion of fastener. Repeat to ensure fasteners are set firmly against top of belt.

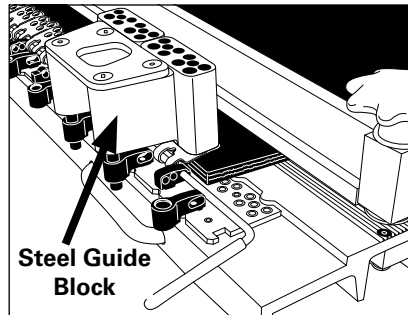

4. Use the steel guide blocks designed for use with this tool.

SR 5 rivet pattern: 42000 (35RD-GB5-4)

SR 8 rivet pattern: 41998 (35RD-GB8-4)

| RIVET SELECTION CHART | | | |
|------------------------------|----------------------|-------------|------------|
| FASTENER SIZE | BELT THICKNESS RANGE | | RIVET SIZE |
| | mm | in. | |
| SR™ RIVET HINGED | | | |
| R5 | 6-8 | 7/32-5/16 | SRA |
| | 7-10 | 9/32-3/8 | SRB |
| | 9-11 | 11/32-7/16 | SRC |
| | 10.5-11 | 13/32-7/16 | SRC/D |
| R5-1/2 & R6LP | 8-9 | 5/16-11/32 | SRB |
| | 8-10.5 | 5/16-13/32 | SRC |
| | 10-12 | 3/8-15/32 | SRC/D |
| | 11-13.5 | 7/16-17/32 | SRD |
| | 13-15 | 1/2-19/32 | SRE |
| | 14-16.5 | 9/16-21/32 | SRF* |
| | 16-18 | 5/8-23/32 | SRG* |
| R6 | 9-11 | 13/32-7/16 | SRC/D |
| | 10.5-13 | 13/32-1/2 | SRD |
| | 12-14 | 15/32-9/16 | SRE |
| | 13.5-16 | 17/32-5/8 | SRF |
| | 15-17 | 19/32-11/16 | SRG |
| R8 | 10.5-11 | 13/32-7/16 | SRC/D |
| | 10.5-13 | 13/32-1/2 | SRD |
| | 12-14 | 15/32-9/16 | SRE |
| | 13.5-16 | 17/32-5/8 | SRF |
| | 15-17 | 19/32-11/16 | SRG |
| R9 | 16-17 | 19/32-11/16 | SRG |
| | 16.5-19 | 21/32-3/4 | SRH |
| | 18-21 | 23/32-13/16 | SRI |
| | 20-22 | 25/32-7/8 | SRJ** |
| | 21-24 | 27/32-15/16 | SRK** |
| BR™ RIVET SOLID PLATE | | | |
| BR10 | 6-8 | 7/32-5/16 | SRA |
| | 7-9.5 | 9/32-3/8 | SRB |
| | 9-11 | 11/32-7/16 | SRC |
| | 10-13 | 13/32-1/2 | SRC/D |
| | 12-14 | 15/32-9/16 | SRD |
| | 13.5-16 | 17/32-5/8 | SRE |
| | 15-17 | 19/32-11/16 | SRF |

* Applies to RAR6LP only.

** Use with 3/4" diameter hinge pin.

Pneumatic Single Rivet Driver

Fastener Installation

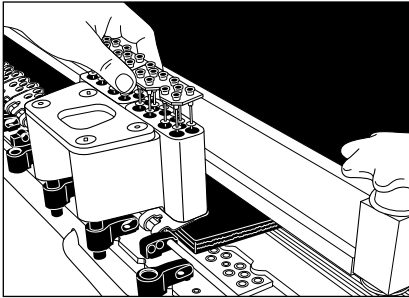

5. Load guide blocks with Rapid Loader™ Collated Rivets *with washers*. **WARNING: Without washers, misfires will occur.** If a shorter strip is needed, break off extra rivets by bending strip at checkpoint.

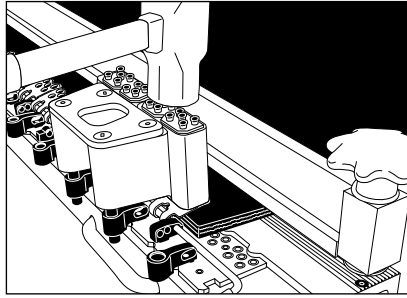

6. Using a hammer, hit the Rapid Loader™ Collated Rivets to release all rivets from plastic. Remove plastic from guide block and discard.

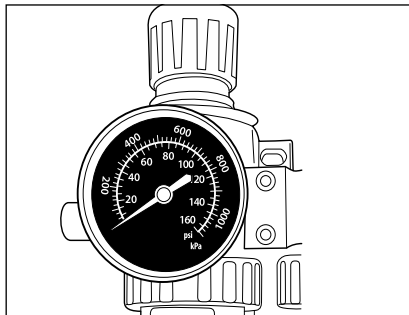

7. Adjust air settings according to the Power Setting Selection Chart (pictured at far right).

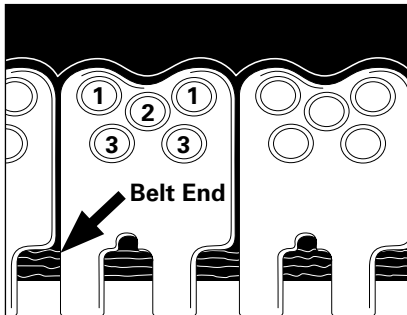

8. Drive rivets in the sequence below:

- a. Drive the row closest to the edge of the fastener
- b. Drive the middle row
- c. Drive the rivets closest to the belt end

NOTE: These values are approximate and may change based on belt construction, temperature and environmental variables. Use a pressure that best meets your specific situation.

| POWER SETTING SELECTION CHART | | |
|-------------------------------|---------------------------|---------|
| RIVET SIZE | Pressure Setting (p.s.i.) | |
| | P.S.I. | Bar |
| A | 40-45 | 2.8-3.1 |
| B | 45-50 | 3.1-3.4 |
| C | 45-55 | 3-4 |
| C/D | 50-60 | 3.5-4.5 |
| D | 55-65 | 3.5-4.5 |
| E | 60-70 | 4-5 |
| F | 65-75 | 4.5-5.5 |
| G | 70-80 | 4.5-5.5 |
| H | 75-85 | 5-6 |
| I | 75-85 | 5-6 |
| J | 80-90 | 5.5-6.5 |
| K | 80-90 | 5.5-6.5 |
| L | 85-95 | 5.5-6.5 |



Pneumatic Single Rivet Driver

Fastener Installation

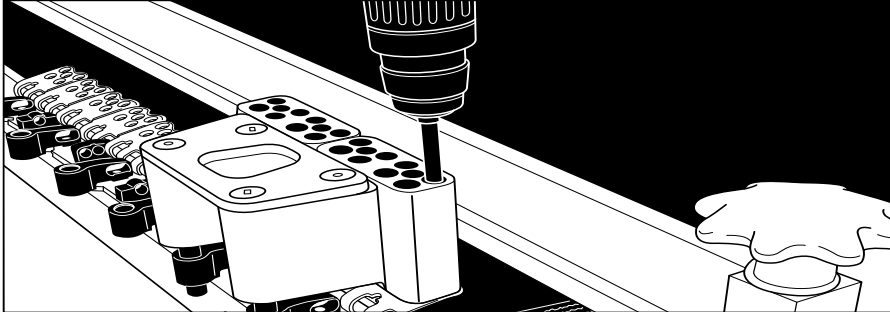

9. Drive one full block on both ends of fastener strip. Drive one full block in the centre of the fastener strip. On both sides, split the difference between the middle and end and drive one full block. Drive remaining rivets.

10. Insert the driver nose directly into the counter bore of the guide block. Press the tool firmly and completely into the guide block. Pull the trigger to drive the rivet.

Start with the specified pressure. If rivet is not fully driven into fastener, use hammer to fully drive rivets. Increase pressure and repeat until the rivet is properly driven into fastener.

If fastener plate is distorted, reduce pressure until rivet is properly driven into fastener.

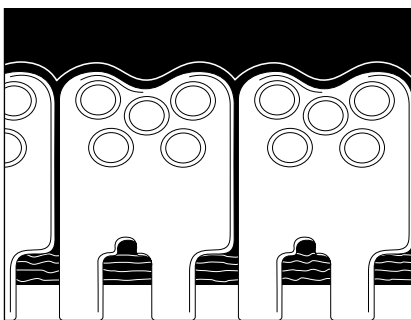

11. Remove guide block(s) and make sure rivets are completely set. Hammer any loose rivets into fasteners to properly set rivets. Hammer scalloped edges of fasteners to set edges into belt.

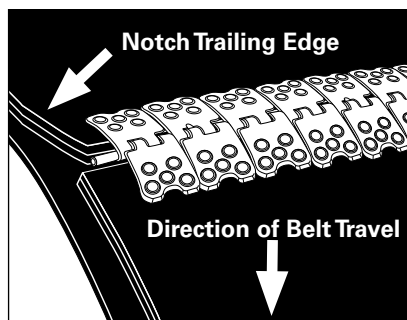

12. Repeat steps 1-11 on other belt end. Bring belt ends together and insert hinge pin. Notch trailing edge of belt only. Splice is complete.

Pneumatic Single Rivet Driver

Maintenance Instructions

Replacement Parts:

FLEXCO replacement parts are recommended. Do not use modified parts or parts which will not give equivalent performance to the original equipment.

Assembly Procedure For Seals:

When repairing a tool, make sure the internal parts are clean and lubricated. Use Parker "O"-LUBE or equivalent on all "O"-rings. Coat each "O"-ring with "O"-LUBE before assembling. Use a small amount of oil on all moving surfaces and pivots. After reassembly add a few drops of Air Tool Lubricant through the air line fitting before testing.

Air Supply-Pressure And Volume:

Air volume is as important as air pressure. The air volume supplied to the tool may be inadequate because of undersize fittings and hoses, or from the effects of dirt and water in the system. Restricted air flow will prevent the tool from receiving an adequate volume of air, even though the pressure reading is high. The results will be slow operation, misfeeds or reduced driving power. Before evaluating tool problems for these symptoms, trace the air supply from the tool to the supply source for restrictive connectors, swivel fittings, low points containing water and anything else that would prevent full volume flow of air to the tool.

Tool Air Fitting:

Tool uses a 3/8" N.P.T. male plug. The inside diameter should be .275" (7mm) or larger. The fitting must be capable of discharging tool air pressure when disconnected from the air supply.

Operating Pressure:

45 to 95 p.s.i./3-6.5 bar

Select the operating pressure within this range for best fastener performance. **DO NOT EXCEED THIS RECOMMENDED OPERATING PRESSURE.** Do not exceed recommended maximum operating pressure as tool wear will be greatly increased. The air supply must be capable of maintaining the operating pressure at the tool. Pressure drops in the air supply can reduce the tool's driving power. Refer to "TOOL SPECIFICATIONS" for setting the correct operating pressure for the tool.

Filter:

Dirt and water in the air supply are major causes of wear in pneumatic tools. A filter will help to get the best performance and minimum wear from the tool. The filter must have adequate flow capacity for the specific installation. The filter has to be kept clean to be effective in providing clean compressed air to the tool. Consult the manufacturer's instructions on proper maintenance of your filter. A dirty and clogged filter will cause a pressure drop which will reduce the tool's performance.

Lubrication:

Frequent, but not excessive, lubrication is required for best performance. Use Air Tool Lubricant, Mobil Velocite #10, or equivalent. Do not use detergent oil or additives as these lubricants will cause accelerated wear to the seals and bumpers in the tool, resulting in poor tool performance and frequent tool maintenance. Only a few drops of oil at a time is necessary. Too much oil will only collect inside the tool and will be noticeable in the exhaust cycle.

Tool Specifications:

All screws and nuts are metric.

Alteration:

Do not alter or modify this tool from the original design or function without approval from FLEXCO.

Disconnect Air Supply:

Always disconnect air supply when servicing the tool or before making adjustments.



Pneumatic Single Rivet Driver

Trouble Shooting

| Problem | Cause | Correction |
|---------------------------------|-------------------------------------------------------------------------------------------------------------------------------------------------------------------------------------------------------------------------------------------------------------------------------|-----------------------------------------------------------------------------------------------------------------------------------------------------------------------------------------------------------------------------------------------------------------------------|
| Trigger valve housing leaks air | O-ring cut or cracked | Replace O-ring |
| Trigger valve stem leaks air | O-ring/seals cut or cracked | Replace trigger valve assembly |
| Frame/nose leaks air | Loose nose screws O-ring or Gasket is cut or cracked Bumper cracked/worn | Tighten and recheck Replace O-ring Replace bumper |
| Frame/cap leaks air | Damaged gasket or seal Cracked/worn head valve bumper Loose cap screws | Replace O-rings Replace bumper Tighten and recheck |
| Failure to cycle | Air supply restriction Tool dry, lack of lubrication Worn head valve O-rings Broken cylinder cap spring Head valve stuck in cap | Check air supply equipment Use BOSTITCH Air Tool Lubricant Replace O-rings Replace cylinder cap spring Disassemble/Check/Lubricate |
| Lack of power; slow to cycle | Tool dry, lacks lubrication Broken cylinder cap spring O-rings/seals cut or cracked Exhaust blocked Trigger assembly worn/leaks Dirt/tar build up on driver Cylinder sleeve not seated correctly on bottom bumper Head valve dry Air pressure too low | Use BOSTITCH Air Tool Lubricant Replace cap spring Replace O-rings/seals Check bumper, head valve spring, muffler Replace trigger assembly Disassemble nose/driver to clean Disassemble to correct Disassemble/lubricate Check air supply equipment |

Pneumatic Single Rivet Driver

Exploding Parts Diagram

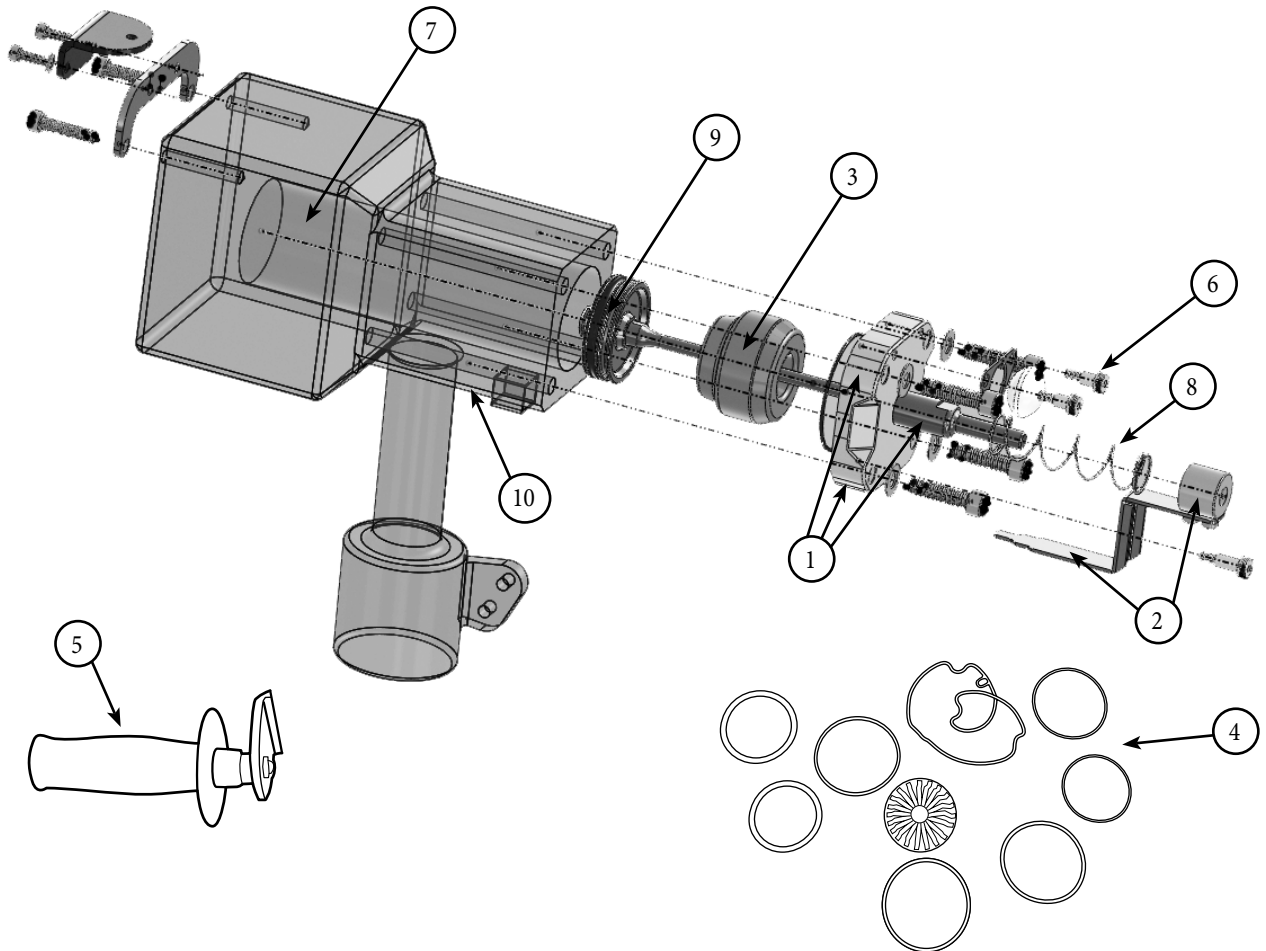

| Call out | Item ID | Description |
|----------|---------|-----------------------------|
| 1 | 41999 | PDNP NOSE PIECE |
| 2 | 42036 | PDNPS NOSE PIECE SAFETY |
| 3 | 42037 | PDBUMP TOOL BUMPER |
| 4 | 42038 | PDORING O-RING REBUILD KIT |
| 5 | 42039 | PDHANDLE HANDLE REPLACEMENT |
| 6 | 42040 | PDHK HARDWARE KIT – SCREWS |
| 7 | 42041 | PDCYL CYLINDER REPLACEMENT |
| 8 | 42042 | PDNSS NOSE SPRING SAFETY |
| 9 | 42043 | PDPR PISTON ROD |
| 10 | 42044 | PDTV TRIGGER VALVE ASSEMBLY |



Flexco (Aust.) Pty. Ltd • 10 Solent Circuit • Baulkham Hills NSW 2153 • Australia
Tel: 612-8818-2000 • Fax: 612-8824-6333 • E-mail: sales@flexco.com.au

Visit www.flexco.com for other Flexco locations and products.

©2012 Flexible Steel Lacing Company. 12-13. For reorder: X3023

