

H-TYPE® Precleaner with V- or VP-Tips

High Efficiency Tungsten-Carbide Precleaner

The Flexco H-Type® Precleaner with V- or Protected V-Tips is designed to be positioned on the head pulley and to remove the bulk of the carryback from the belt. Proven performance over 20 years as the most efficient pre-cleaner in material handling applications such as coal, iron ore, bauxite and hard rock mining with vulcanized belts.

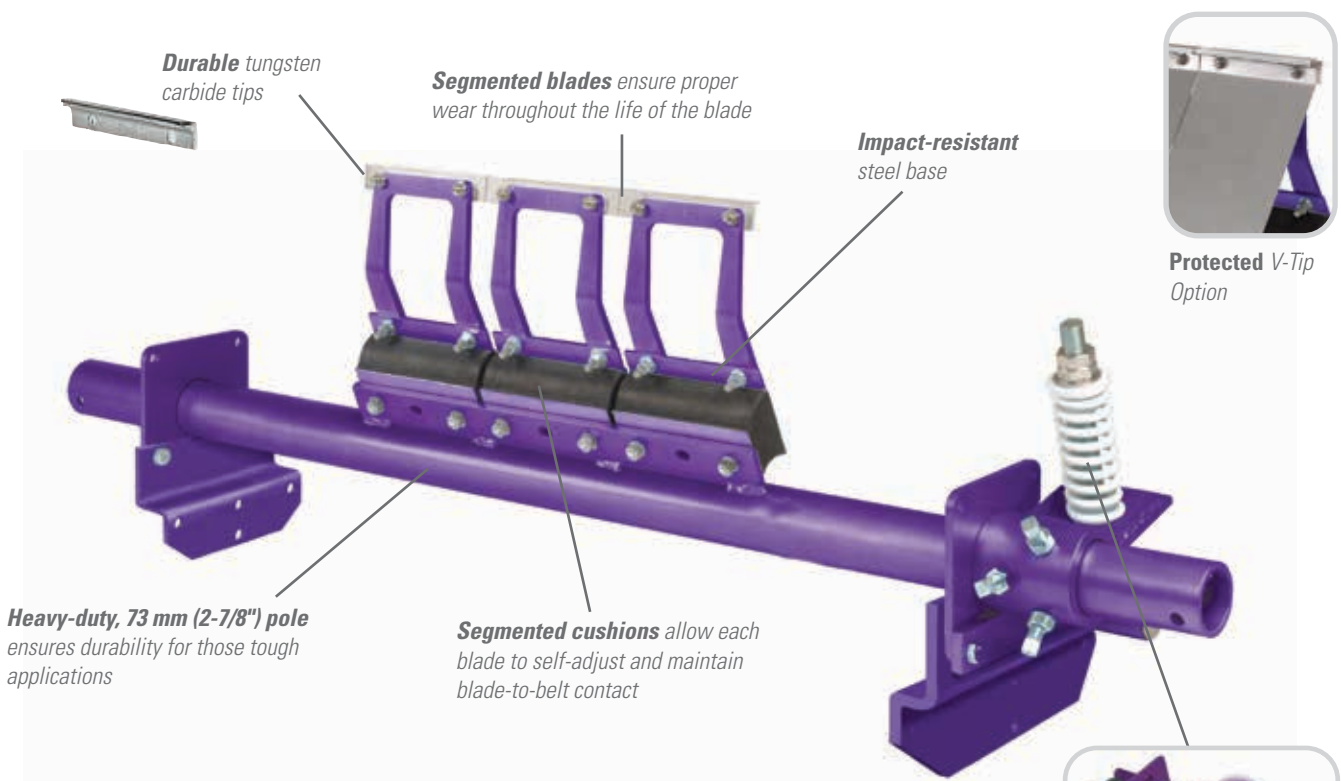

Features and Benefits

- **Works with vulcanized belts.** The tungsten carbide tips allow for maximum cleaning efficiency and superior wear characteristics. Also available with protected tips for abrasive applications.
- **Complete cleaning system.** When teamed with a secondary cleaner, it makes up a system that delivers maximum cleaning power for the most abusive conveyor applications.
- **Made for mining conveyors.** Made from heavy-duty steel with corrosion-resistant powder coating, the H-Type is available in sizes for belt widths from 450 to 1800mm (18" to 72"). Additional sizes are available upon request.
- **Optimal positioning.** Blade contact on the pulley is 15° below the horizontal centerline. This keeps the blades out of the discharge path and protects them from rocks, large lumps and other debris.



Quick Mount Tensioner (QMT)
allows the blade tension to be visually inspected

H-TYPE® Precleaner with V- or VP-Tips

Specifications and Guidelines

Maximum Belt Speed

5 m/s (1000 FPM)

Temperature Rating

-35° C to 82° C (-30° F to 180° F)

Minimum Pulley Diameter

250mm (10")

CEMA Cleaner Rating

Class 4

Usable Blade Wear Length

9mm (3/8")

Blade Material

Tungsten carbide (for vulcanized belts only)

Available for Belt Widths

450 to 1800mm (18" to 72")

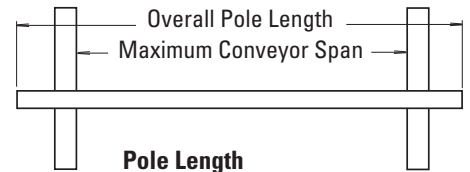

Pole Length

Cleaner size + 1200mm (48")

Maximum Conveyor Span

Cleaner size + 950mm (38")

Ordering Information

H-Type® with V-Tips*

Belt Width	Suspension Arm Size	Ordering Number	Item Code
in.	mm		
18	450	SS	HV-18SS 76101
18	450	S	HV-18S 76190
18	450	M	HV-18M 76191
24	600	SS	HV-24SS 76102
24	600	S	HV-24S 76192
24	600	M	HV-24M 76193
30	750	SS	HV-30SS 76103
30	750	S	HV-30S 76194
30	750	M	HV-30M 76195
36	900	SS	HV-36SS 76104
36	900	S	HV-36S 76196
36	900	M	HV-36M 76197
36	900	L	HV-36L 76198
42	1050	SS	HV-42SS 76105
42	1050	S	HV-42S 76199
42	1050	M	HV-42M 76251
42	1050	L	HV-42L 76252
42	1050	LL	HV-42LL 76253
48	1200	SS	HV-48SS 76106
48	1200	S	HV-48S 76254
48	1200	M	HV-48M 76255
48	1200	L	HV-48L 76256
48	1200	LL	HV-48LL 76257
54	1350	S	HV-54S 76107
54	1350	M	HV-54M 76258
54	1350	L	HV-54L 76259
54	1350	LL	HV-54LL 76260
60	1500	S	HV-60S 76108
60	1500	M	HV-60M 76261
60	1500	L	HV-60L 76262
60	1500	LL	HV-60LL 76263
72	1800	S	HV-72S 76109
72	1800	M	HV-72M 76264
72	1800	L	HV-72L 76265
72	1800	LL	HV-72LL 76266

*NOTE: V-Tips can be used ONLY on vulcanized belts. Suspension arm size is determined by head pulley diameter - see chart. Additional sizes available upon request. Lead time: 1 working day

H-Type with Protected V-Tips*

For abusive applications where materials being cleaned off the belt wear the back sides of the cleaner's V-Tips.

Belt Width	Suspension Arm Size	Ordering Number	Item Code
in.	mm		
18	450	S	HVP-18S 76124
18	450	M	HVP-18M 76267
18	450	L	HVP-18L 76268
24	600	S	HVP-24S 76125
24	600	M	HVP-24M 76269
24	600	L	HVP-24L 76270
30	750	S	HVP-30S 76126
30	750	M	HVP-30M 76271
30	750	L	HVP-30L 76272
36	900	S	HVP-36S 76127
36	900	M	HVP-36M 76273
36	900	L	HVP-36L 76274
42	1050	S	HVP-42S 76128
42	1050	M	HVP-42M 76275
42	1050	L	HVP-42L 76276
48	1200	S	HVP-48S 76129
48	1200	M	HVP-48M 76277
48	1200	L	HVP-48L 76278
48	1200	LL	HVP-48LL 76279
54	1350	S	HVP-54S 76130
54	1350	M	HVP-54M 76280
54	1350	L	HVP-54L 76281
54	1350	LL	HVP-54LL 76282
60	1500	S	HVP-60S 76131
60	1500	M	HVP-60M 76283
60	1500	L	HVP-60L 76284
60	1500	LL	HVP-60LL 76285
72	1800	S	HVP-72S 76132
72	1800	M	HVP-72M 76286
72	1800	L	HVP-72L 76287
72	1800	LL	HVP-72LL 76288

*NOTE: Protected V-Tips can be used ONLY on vulcanized belts. Suspension arm size is determined by head pulley diameter - see chart. Cleaners come standard with Stainless Steel Tip Shields. Additional sizes available upon request. Lead time: 1 working day

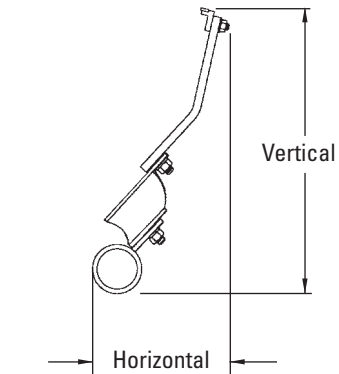

Horizontal Clearance Required
175mm (7")

Vertical Clearance Required

SS: 325mm (13")

S: 375mm (15")

M: 413mm (16-1/2")

L: 463mm (18-1/2")

LL: 550mm (22")

Suspension Arm Size

Head Pulley Diameter + Belt & Lagging		Suspension Arm Size
mm	in.	
250-475	10 - 19	SS
500-775	20 - 31	S
800-975	32 - 39	M
1000-1175	40 - 47	L
1200-1675	48 - 67	LL

Replacement V-Tips

Ordering Number	Item Code
HVT8-S/S	75419

Lead time: 1 working day

Replacement Protected V-Tips

Ordering Number	Item Code
HVPT	73631

Lead time: 1 working day

Authorized Distributor:

New Door No. 51 • Anna Salai, Nagalkeni • Pammal Village • Chennai - 600 044 • Tamil Nadu • India
Tel: +91-44-4856-6762 • E-mail: info.india@flexco.com

Visit www.flexco.com for other Flexco locations and products.

©2020 Flexible Steel Lacing Company. 02/05/20. For reorder: X2967

