

MHS Stainless Heavy-Duty Secondary Belt Cleaner

Superior Cleaning on the Toughest Belts

The MHS Heavy-Duty Stainless Steel Secondary Belt Cleaner was designed to deliver and maintain superior cleaning efficiency, even on the most demanding, abusive beltlines. The MHS SS is the new answer to tough belt cleaning problems. It delivers high-efficiency cleaning and long-lasting performance, with low maintenance.

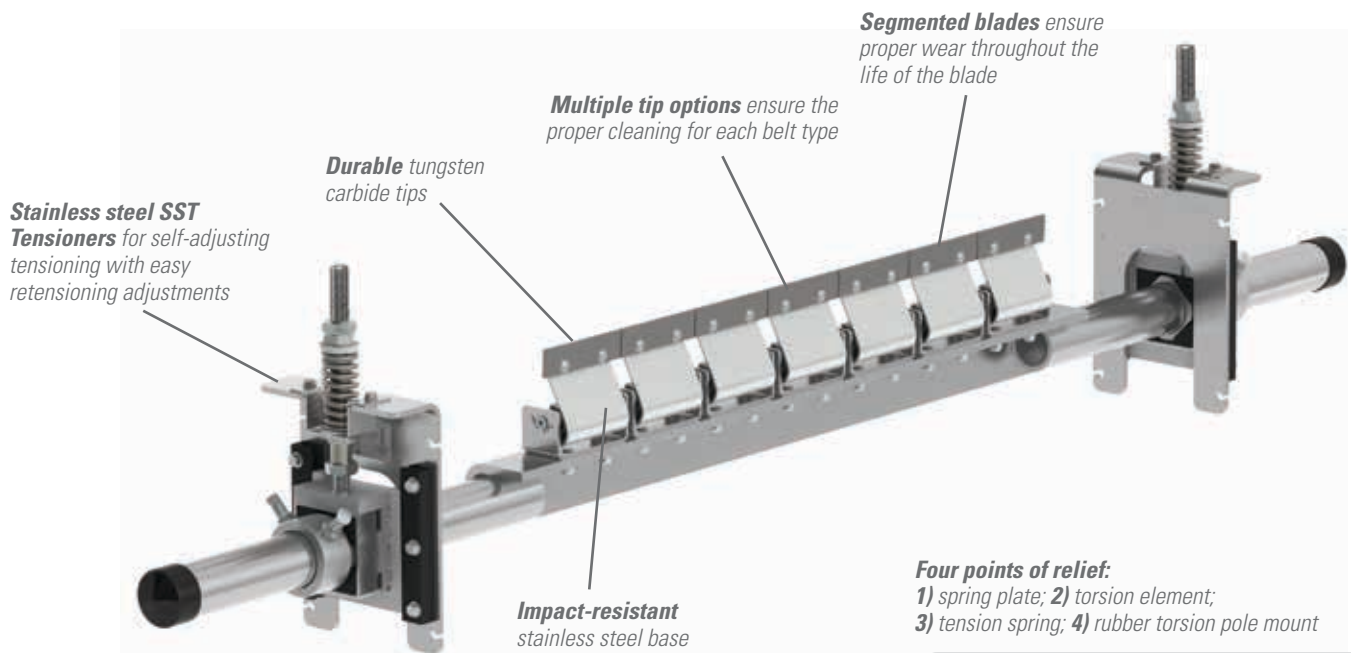

Features and Benefits

- **Stainless steel.** Corrosive environments wear on any component, but stainless steel can protect against that.
- **Cleaning efficiency of metal blades.** The thin, hard edges of the metal blades deliver high cleaning efficiency and long wear life.
- **Works with Flexco and other mechanical splices.** The C-Tip tungsten carbide blades are impact resistant, and the spring cushion allows them to move away from a passing splice without damage and with minimal cleaning disruption. The V-Tip can be used on vulcanized belts.
- **Made for mining conveyors.** Made from heavy-duty, corrosion-resistant stainless steel, the MHS is available for belt widths from 600 to 2400mm (24" to 96"). Additional sizes are available upon request.
- **Complete cleaning system.** When the MHS is teamed with the MMP Precleaner, the system provides maximum cleaning power for tough applications.
- **Safe to service.** All service can be performed from a safe position at the side of the conveyor.

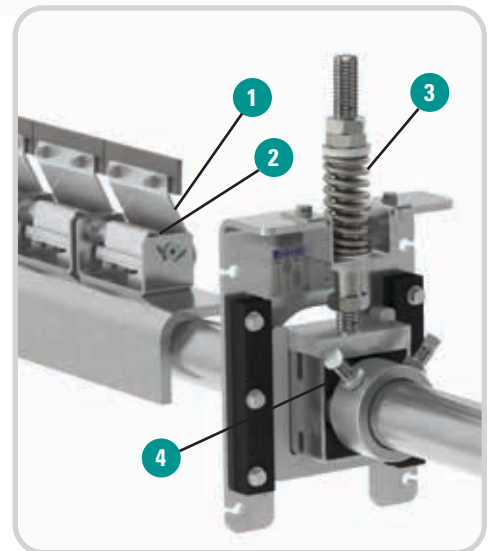

MHS Stainless

Heavy-Duty Secondary Belt Cleaner

Specifications and Guidelines

- Maximum Belt Speed**
 6 m/s (1200 FPM)
- Temperature Rating**
 -35°C to 82°C (-30°F to 180°F)
- Useable Blade Wear Length**
 9 mm (3/8")
- Blade Material**
 Impact resistant, long-lasting tungsten carbide (C-Tip for mechanical fasteners, V-Tip for vulcanized belts)
- Available for Belt Widths**
 450 to 2400mm (24" to 96")
- Horizontal Clearance Required**
 100mm (4")
- Vertical Clearance Required**
 238mm (9-1/2")
- Pole Length**
 Cleaner size + 1350mm (54")
- Maximum Conveyor Span**
 Cleaner size + 1100mm (44")

Clearance Requirement Specs

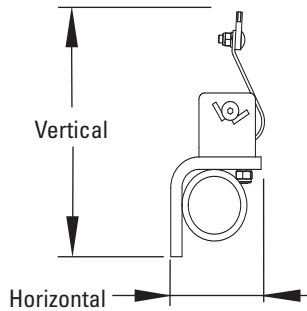

Pole Length and Conveyor Span Specs

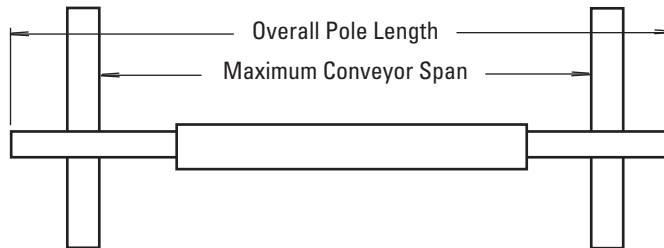

Ordering Information

MHS SS Secondary Cleaners with C-Tips				
Belt Width		Ordering Number	Item Code	
mm	in.			
600	24	MHS-24-S/S	77601	
750	30	MHS-30-S/S	77602	
900	36	MHS-36-S/S	77603	
1050	42	MHS-42-S/S	77604	
1200	48	MHS-48-S/S	77605	
1350	54	MHS-54-S/S	77606	
1500	60	MHS-60-S/S	77607	
1800	72	MHS-72-S/S	77608	
2100	84	MHS-84-S/S	77609	
2400	96	MHS-96-S/S	79048	

MHS SS Secondary Cleaners with V-Tips				
Belt Width		Ordering Number	Item Code	
mm	in.			
600	24	MHS-24V-S/S	77610	
750	30	MHS-30V-S/S	77611	
900	36	MHS-36V-S/S	77612	
1050	42	MHS-42V-S/S	77613	
1200	48	MHS-48V-S/S	77614	
1350	54	MHS-54V-S/S	77615	
1500	60	MHS-60V-S/S	77616	
1800	72	MHS-72V-S/S	77617	
2100	84	MHS-84V-S/S	77618	
2400	96	HS-96V-S/S	79049	

MHS SS Reversing Secondary Cleaners with C-Tips				
Belt Width		Ordering Number	Item Code	
mm	in.			
600	24	MHS-24R-S/S	77640	
750	30	MHS-30R-S/S	77641	
900	36	MHS-36R-S/S	77642	
1050	42	MHS-42R-S/S	77643	
1200	48	MHS-48R-S/S	77644	
1350	54	MHS-54R-S/S	77645	
1500	60	MHS-60R-S/S	77646	
1800	72	MHS-72R-S/S	77647	
2100	84	MHS-84R-S/S	77648	
2400	96	MHS-96R-S/S	79050	

MHS SS Reversing Secondary Cleaners with V-Tips				
Belt Width		Ordering Number	Item Code	
mm	in.			
600	24	MHS-24RV-S/S	77649	
750	30	MHS-30RV-S/S	77650	
900	36	MHS-36RV-S/S	77651	
1050	42	MHS-42RV-S/S	77652	
1200	48	MHS-48RV-S/S	77653	
1350	54	MHS-54RV-S/S	77654	
1500	60	MHS-60RV-S/S	77655	
1800	72	MHS-72RV-S/S	77656	
2100	84	MHS-84RV-S/S	77657	
2400	96	MHS-96RV-S/S	79051	

Lead time: 1 working day

Shaded items are made to order.
Lead time: 3 weeks

Replacement Tips	
Ordering Number	Item Code
ICT6	74535
RSA150	73628

Lead time: 1 working day

Tips Required Per Cleaner Size												
mm	450	600	750	900	1050	1200	1350	1500	1800	2100	2400	
in.	18	24	30	36	42	48	54	60	72	84	96	
C-Tips or V-Tips Required	3	4	5	6	7	8	9	10	12	14	16	

Authorized Distributor:

New Door No. 51 • Anna Salai, Nagalkeni • Pammal Village • Chennai - 600 044 • Tamil Nadu • India
Tel: +91-44-4856-6762 • E-mail: info.india@flexco.com

Visit www.flexco.com for other Flexco locations and products.

©2020 Flexible Steel Lacing Company. 01/15/20. For reorder: X2961

