

MSP Stainless Standard-Duty Precleaner

Economical and Effective

The MSP Standard-Duty Precleaner is not your average solid-blade belt cleaner that mounts on the head pulley. It is a mine-tough design that combines simple, do-it-yourself installation, quick maintenance and effective cleaning results with an affordable price tag.

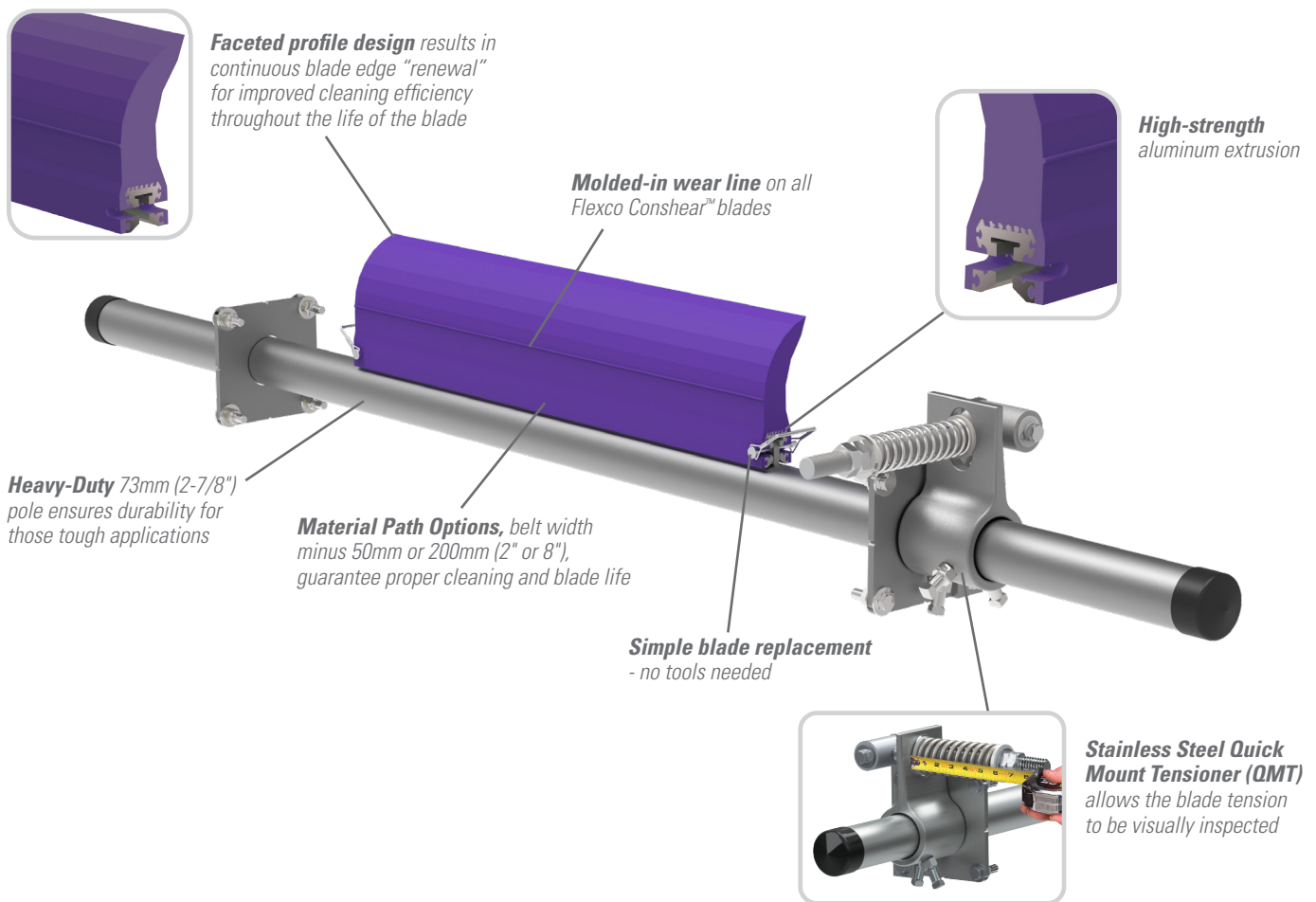

Features and Benefits

- **Stainless steel.** Corrosive environments wear on any component, but stainless steel can protect against that.
- **Quick-change blade.** No tools are needed. Just pull one pin, remove the old blade, slide in the new one and replace the pin.
- **Works with Flexco and other mechanical splices.** The spring tensioner quickly moves the blade away from the belt when a splice passes. The polyurethane blade easily glides over the splice without damage and with minimal cleaning disruption.
- **Easy to service.** All maintenance work is done from the easy-access side of the beltline. Blade retensioning and change-out are quick and easy.
- **Fits most conveyor structures.** Available for belt widths from 300 to 2100mm (12 to 84"). The MSP SS poles are extra long (belt width plus 1350mm (54")) to accommodate varying structure widths.

MSP Stainless

Standard-Duty Precleaner

Specifications and Guidelines

- **Maximum Belt Speed**
3.5 m/s (700 FPM)
- **Temperature Rating**
-35 to 82°C (-30 to 180°F)
- **Minimum Pulley Diameter**
400mm (16")
- **Blade Height**
185mm (7-1/4")
- **Usable Blade Wear Length**
100mm (4")
- **Blade Material**
Urethane 83 durometer
(proprietary blend for abrasion resistance and long wear)
- **Available for Belt Widths**
600 to 2100mm (24 to 84")
- **Horizontal Clearance Required**
100mm (4")
- **Vertical Clearance Required**
254mm (10")
- **Pole Length**
Cleaner size + 1350mm (54")
- **Maximum Conveyor Span**
Cleaner size + 1100mm (44")

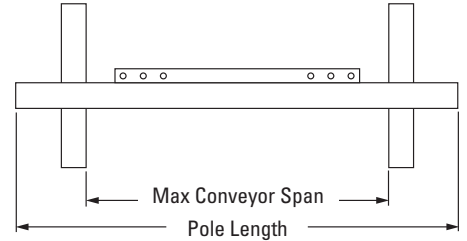
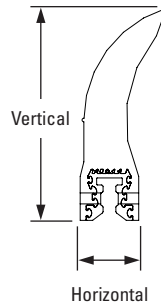

Ordering Information

MSP Stainless Steel Precleaner Belt Width Minus 50mm (2")					
Belt Width		Blade Width		Ordering Number	Item Code
mm	in.	mm	in.		
600	24	550	22	MSP-224-S/S	77453
750	30	700	28	MSP-230-S/S	77454
900	36	850	34	MSP-236-S/S	77455
1050	42	1000	40	MSP-242-S/S	77456
1200	48	1150	46	MSP-248-S/S	77457
1350	54	1300	52	MSP-254-S/S	77458
1500	60	1450	58	MSP-260-S/S	77459
1800	72	1750	70	MSP-272-S/S	77460
2100	84	2050	82	MSP-284-S/S	77461

Belt Width Minus 200mm (8")					
Belt Width		Blade Width		Ordering Number	Item Code
mm	in.	mm	in.		
600	24	400	16	MSP-824-S/S	77462
750	30	550	22	MSP-830-S/S	77463
900	36	700	28	MSP-836-S/S	77464
1050	42	850	34	MSP-842-S/S	77465
1200	48	1000	40	MSP-848-S/S	77466
1350	54	1150	46	MSP-854-S/S	77467
1500	60	1300	52	MSP-860-S/S	77468
1800	72	1600	64	MSP-872-S/S	77470
2100	84	1900	76	MSP-884-S/S	77471

Lead time: 3 weeks

Replacement ConShear™ Blades			
Blade Width		Ordering Number	Item Code
mm	in.		
250	10	CRB 250	76582
400	16	CRB 400	76583
550	22	CRB 550	76584
700	28	CRB 700	76585
850	34	CRB 850	76586
1000	40	CRB 1000	76587
1150	46	CRB 1150	76588
1300	52	CRB 1300	76589
1450	58	CRB 1450	76590
1600	64	CRB 1600	76591

Other blade sizes available upon request.

Pole Location Specs

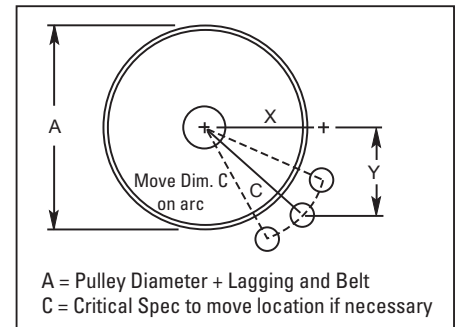

Pole Location Chart

A		X		Y		C	
mm	in.	mm	in.	mm	in.	mm	in.
250	10	68	2 5/8	230	9	240	9 4/8
275	11	88	3 4/8	230	9	246	9 6/8
300	12	102	4	230	9	252	9 7/8
325	13	130	5 1/8	230	9	264	10 3/8
350	14	142	5 5/8	230	9	270	10 5/8
375	15	164	6 4/8	230	9	282	11 1/8
400	16	176	7 1/8	230	9	290	11 1/2
425	17	196	7 7/8	230	9	302	12
450	18	204	8 1/4	230	9	308	12 1/4
475	19	222	9	230	9	320	12 3/4
500	20	232	9 3/8	230	9	326	13
525	21	248	10	230	9	338	13 1/2
550	22	266	10 3/4	230	9	352	14
575	23	282	11 3/8	230	9	364	14 1/2
600	24	298	12	230	9	376	15
625	25	312	12 5/8	230	9	388	15 1/2
650	26	330	13 1/4	230	9	402	16
675	27	344	13 7/8	230	9	414	16 1/2
700	28	358	14 3/8	230	9	426	17
725	29	372	15	230	9	438	17 1/2
750	30	390	15 5/8	230	9	452	18
775	31	402	16 1/8	230	9	464	18 1/2
800	32	416	16 3/4	230	9	476	19
825	33	430	17 1/4	230	9	488	19 1/2
850	34	446	17 7/8	230	9	502	20
875	35	460	18 3/8	230	9	514	20 1/2
900	36	474	19	230	9	526	21
925	37	486	19 1/2	230	9	538	21 1/2
950	38	502	20	230	9	552	22
975	39	514	20 5/8	230	9	564	22 1/2
1000	40	528	21 1/8	230	9	576	23
1025	41	542	21 3/4	230	9	588	23 1/2
1050	42	556	22 1/4	230	9	602	24

Visit www.flexco.com for other Flexco locations and products, or to find an authorised distributor.

©2020 Flexible Steel Lacing Company. 08-05-24. X2958

