

MSP Stainless Standard-Duty Precleaner

Effective for Corrosive Environments

The MSP Stainless Steel Standard-Duty Precleaner is not your average solid-blade belt cleaner that mounts on the head pulley. It is a mine-tough design that combines simple, do-it-yourself installation, quick maintenance and effective cleaning results with the added advantage of corrosion resistant stainless steel components.

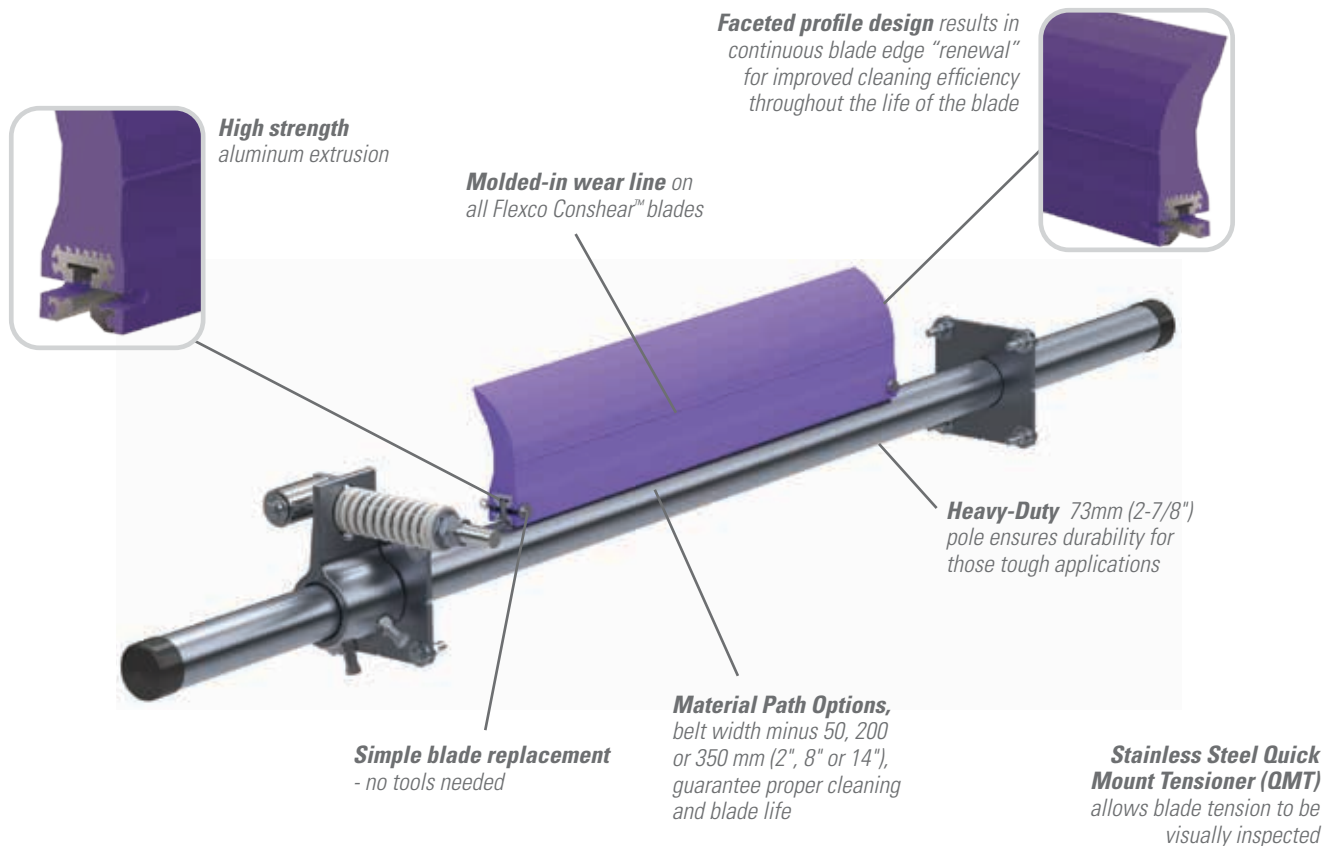

Features and Benefits

- **Stainless steel.** Corrosive environments wear on any component, but stainless steel can protect against that.
- **Quick-change blade.** No tools are needed. Just pull one pin, remove the old blade, slide in the new one and replace the pin.
- **Works with Flexco and other mechanical splices.** The spring tensioner quickly moves the blade away from the belt when a splice passes. The polyurethane blade easily glides over the splice without damage and with minimal cleaning disruption.
- **Easy to service.** All maintenance work is done from the easy-access side of the beltline. Blade retensioning and change-out are quick and easy.
- **Fits most conveyor structures.** Available for belt widths from 300-2100 mm (12" to 84"). The MSP SS poles are extra long (belt width plus 1350mm/54") to accommodate varying structure widths.



MSP Stainless

Standard-Duty Precleaner

Specifications and Guidelines

- **Maximum Belt Speed**
3.5 m/s (700 FPM)
- **Temperature Rating**
-35°C to 82°C (-30°F to 180°F)
- **Minimum Pulley Diameter**
400mm (16")
- **Blade Height**
185mm (7-1/4")
- **Useable Blade Wear Length**
100mm (4")
- **Blade Material**
Urethane 83 durometer (proprietary blend for abrasion resistance and long wear)
- **Available for Belt Widths**
600 to 2100mm (24" to 84")
- **Horizontal Clearance Required**
100mm (4")
- **Vertical Clearance Required**
250mm (10")
- **Pole Length**
Cleaner size + 54" (1350mm)
- **Maximum Conveyor Span**
Cleaner size + 44" (1100mm)

Pole Location Specs

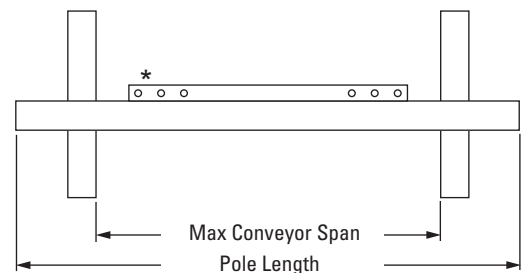
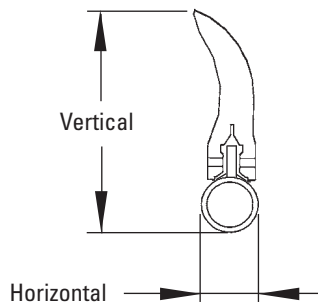
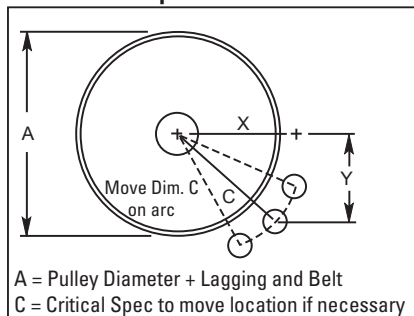

Pole Location Chart

A	X	Y	C	A	X	Y	C	A	X	Y	C
400	179	230	291	625	314	230	390	850	446	230	501
425	195	230	301	650	330	230	402	875	460	230	514
450	207	230	309	675	346	230	415	900	474	230	526
475	223	230	320	700	360	230	427	925	488	230	539
500	235	230	329	725	374	230	439	950	502	230	552
525	249	230	339	775	389	230	452	975	516	230	565
550	266	230	352	775	403	230	464	1000	529	230	576
575	283	230	365	825	417	230	477	1025	542	230	589
600	299	230	377	825	432	230	489	1050	557	230	602

Ordering Information

MSP SS Precleaners - Belt Width Minus 50 mm (2")					
Belt Width		Blade Coverage		Ordering Number	Item Code
mm	in.	mm	in.		
600	24	550	22	MSP-224-S/S	77453
750	30	700	28	MSP-230-S/S	77454
900	36	850	34	MSP-236-S/S	77455
1050	42	1000	40	MSP-242-S/S	77456
1200	48	1150	46	MSP-248-S/S	77457
1350	54	1300	52	MSP-254-S/S	77458
1500	60	1450	58	MSP-260-S/S	77459
1800	72	1750	70	MSP-272-S/S	77460
2100	84	2050	82	MSP-284-S/S	77461

MSP SS Precleaners - Belt Width Minus 200 mm (8")					
Belt Width		Blade Coverage		Ordering Number	Item Code
mm	in.	mm	in.		
600	24	400	16	MSP-824-S/S	77462
750	30	550	22	MSP-830-S/S	77463
900	36	700	28	MSP-836-S/S	77464
1050	42	850	34	MSP-842-S/S	77465
1200	48	1000	40	MSP-848-S/S	77466
1350	54	1150	46	MSP-854-S/S	77467
1500	60	1300	52	MSP-860-S/S	77468
1800	72	1600	64	MSP-872-S/S	77470
2100	84	1900	76	MSP-884-S/S	77471

ConShear™ Replacement Blades			
Blade Width		Ordering Number	Item Code
mm	in.		
400	16	CRB16	75629
550	22	CRB22	75630
700	28	CRB28	75631
850	34	CRB34	75632
1000	40	CRB40	75633
1150	46	CRB46	75634
1300	52	CRB52	75635
1450	58	CRB58	75636
1600	64	CRB64	75775
1750	70	CRB70	75773
1900	76	CRB76	76940
2050	82	CRB82	76941

Lead time: 1 working day

Shaded items are made to order.
Lead time: 3 weeks

Authorized Distributor:

New Door No. 51 • Anna Salai, Nagalkeni • Pammal Village • Chennai - 600 044 • Tamil Nadu • India
Tel: +91-44-4856-6762 • E-mail: info.india@flexco.com

Visit www.flexco.com for other Flexco locations and products.

©2020 Flexible Steel Lacing Company. 01/15/20. For reorder: X2958

