

P-TYPE[®] LS

Limited Space Secondary Belt Cleaner

Reliable Secondary Belt Cleaner

The Flexco P-Type[®] LS Secondary Belt Cleaner is compact and designed to be positioned just off the head pulley to remove carryback from the belt. Stand alone, or when used in conjunction with a precleaner, the P-Type LS cleaner is a reliable choice for maintaining a highly efficient cleaning system.

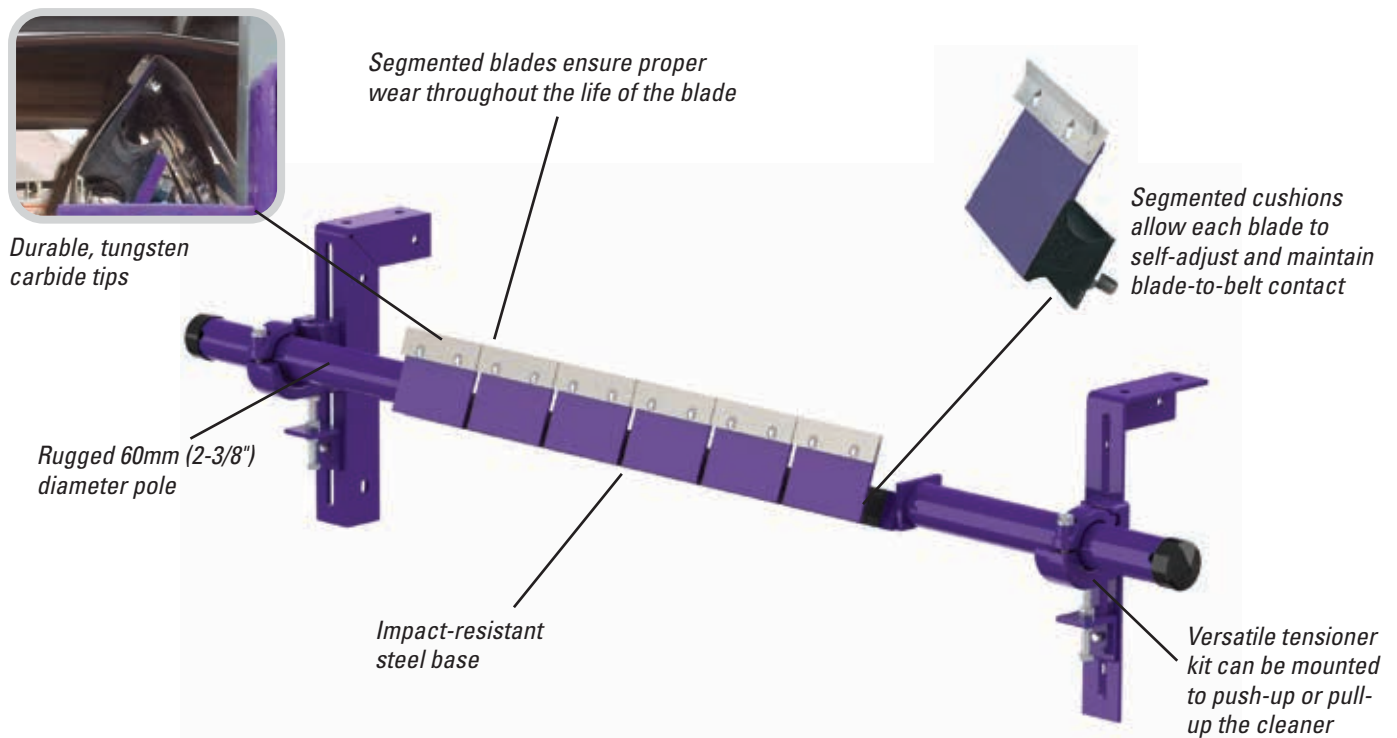

Features and Benefits

- **Cleaning efficiency of metal blades.** The thin, hard edges of the metal blades deliver high cleaning efficiency and long wear life.
- **Works with Flexco mechanical splices.** The C-Tip tungsten carbide blades are impact-resistant, and the spring cushion allows them to move away from a passing splice without damage and with minimal cleaning disruption.
- **A complete cleaning system.** When the P-Type LS is teamed with a primary cleaner the system provides maximum cleaning power for tough applications.
- **Fits most conveyor structures.** Available for belt widths from 450 mm to 1350 mm (18" to 54").

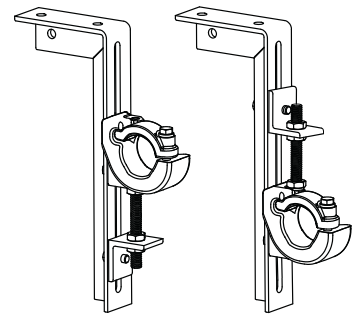

P-TYPE® LS Secondary Belt Cleaner

Specifications and Guidelines

Maximum Belt Speed

5 m/s (1000 FPM)

Temperature Rating

-35° C to 82° C (-30° F to 180° F)

Usable Blade Wear Length

9 mm (3/8")

Blade Material

Impact resistant, long-lasting tungsten carbide

Available for Belt Widths

450 to 1350mm (18" to 54")

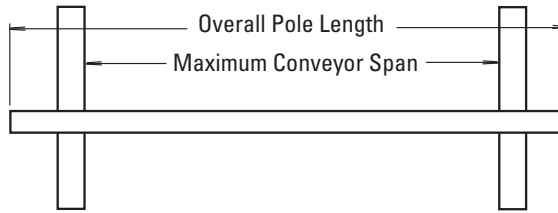

Pole Length

Cleaner size up to 1200mm (48") + 750mm (30")/Cleaner size 1350mm (54") and up + 850mm (34")

Maximum Conveyor Span

Cleaner size up to 1200mm (48") + 625mm (25")/Cleaner size 1350mm (54") and up + 725mm (29")

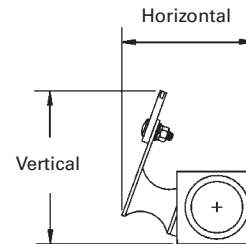

Horizontal Clearance Required

125mm (5")

Vertical Clearance Required

138mm (5-1/2")

The PLS Cleaner fits on telescoping, stacking and portable conveyors.

Ordering Information

P-Type® LS Secondary with C-Tips*			
Belt Width		Ordering Number	Item Code
mm	in.		
450	18	PLSC18	75588
600	24	PLSC24	75589
750	30	PLSC30	75590
900	36	PLSC36	75591
1050	42	PLSC42	75592
1200	48	PLSC48	75593
1350	54	PLSC54	75594

*NOTE: C-Tips can be used on mechanically spliced and vulcanized belts. P-Type LS cleaners come standard with Select Set™ Tensioners.

Replacement Tips	
Ordering Number	Item Code
ICT6	74535

Lead time: 1 working day

Tips Required per Cleaner Size							
mm	450	600	750	900	1050	1200	1350
in.	18	24	30	36	42	48	54
C-Tips Required	3	4	5	6	7	8	9

Additional Information

For standard applications, see the P-Type Sell Sheet X2397.



Authorized Distributor:

New Door No. 51 • Anna Salai, Nagalkeni • Pammal Village • Chennai - 600 044 • Tamil Nadu • India
Tel: +91-44-4856-6762 • E-mail: info.india@flexco.com

Visit www.flexco.com for other Flexco locations and products.

©2021 Flexible Steel Lacing Company. 05/27/21. For reorder: Xxxxx

