

# Hitch Guard - for Scanner Eye Application Installation Instructions

## Parts Included in Hitch Guard Kit:

- Hitch Guard Support Bar (1)
- Center Segments
- Right End Segment (1)
- Left End Segment (1)
- Mounting Plates (2)
- 1/4-20 x 1.5" Flush Head Cap Screws (4)
- 1/4" Flat Washers (4)
- 1/4-20 Nylok Nuts (4)
- Hitch Guard Set-up Gauges (2)

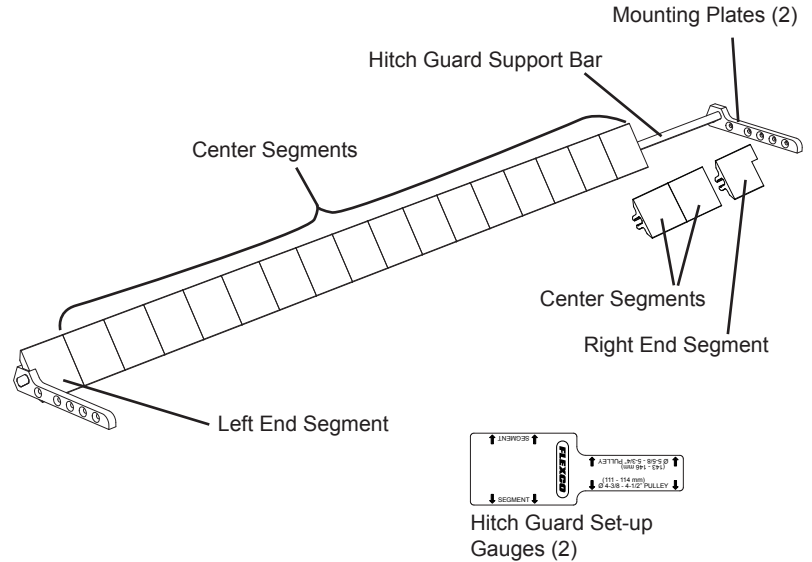

## Tools Required for Installation:

- |                               |                                        |
|-------------------------------|----------------------------------------|
| - Drill                       | - 1/4" (6 mm) Transfer Punch           |
| - Cutoff Saw                  | - Steel Hammer                         |
| - Table Saw                   | - Soft Face Mallet                     |
| - 3/32" (2.4 mm) Drill Bit    | - 7/16" (11 mm) Open End Wrench OR     |
| - 9/32" (7 mm) Drill Bit      | 7/16" (11 mm) Socket and Ratchet Drive |
| - Large Flat Head Screwdriver | - 5/32" (4 mm) Hex Key                 |

1. Measure head pulley diameter at hitch if diameter is not already known.
2. Measure inside-to-inside width of the side panels at hitch within 1/16" (1.5 mm) accuracy (Fig. 1).
3. Cut hitch guard support bar 1/16" to 1/8" (1.5 to 3 mm) shorter than measured dimension from Step 2. Deburr ends of hitch guard support bar if burrs are present.
4. Install all hitch guard segments onto pole, including left end and right end segments, leaving space for the last two center segments (Fig. 2).

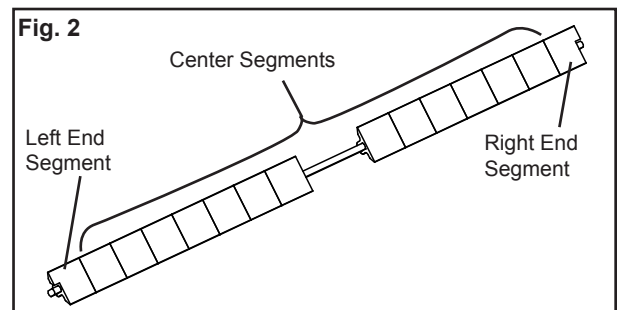
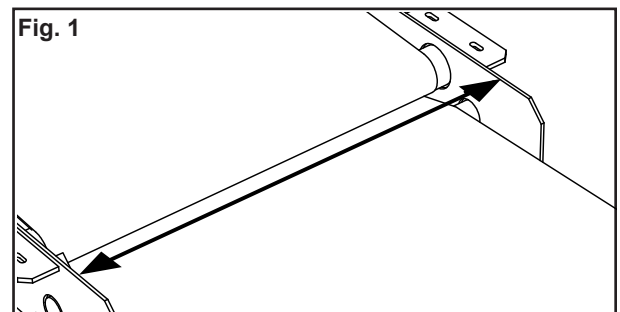

5. Slide steel mounting plates onto each end of support bar as shown, with “step” facing upward (Fig. 3).

6. Place assembled hitch guard into position on conveyor belt, filling the gap in the hitch.

7. Using supplied Hitch Guard Set-up Gauges, place the corresponding pulley diameter side against top pulley and the segment indicated side against the flat face of the segment (Fig. 4).

8. Properly position the Hitch Guard by rotating the hitch guard until the segment side of the Set-up Gauge is flush with the flat face of the hitch guard, the pulley side of the gauge is resting against the top pulley/belt, and the lower edge of the hitch guard is making light contact with the lower belt (Fig. 5a & 5b). Fig. 5c illustrates proper finished segment orientation.

9. With hitch guard properly positioned, use transfer punch and steel hammer or paint marker to transfer two mounting plate holes to inside walls of side panels. First transfer hole should be closest to support bar. Second transfer hole should be the farthest away that the structure will allow. **DO NOT USE TWO ADJACENT HOLES.** **NOTE:** To prevent movement of hitch guard or mounting plate, have someone hold the bar or place knee or heavy object against installed segment.

10. Remove hitch guard. Using a 3/32" (2.4 mm) drill bit, drill pilot hole. Finish drilling hole with a 9/32" (7 mm) drill bit. Remove burrs and debris.

11. Return hitch guard assembly to mounting position.

12. Insert 1/4-20 x 1.5" flush head cap screws through mounting plate and drilled holes in side panels. On outside surface of side panel, loosely install 1/4" flat washer and 1/4-20 Nylok nut on each 1/4-20 x 1.5" flush head cap screw (Fig. 6). Complete this step for remaining three mounting locations.

13. Use included set-up gauges to verify position of hitch guard before final tightening of hardware (see Steps 7 & 8).

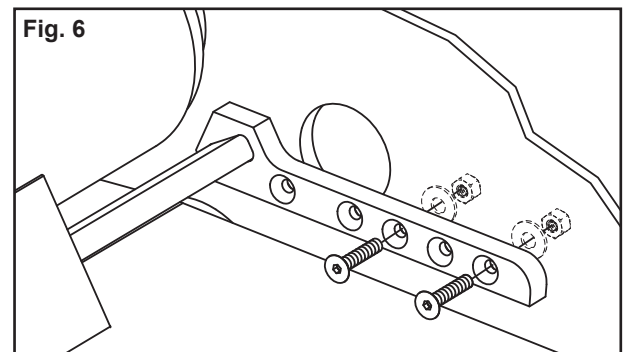
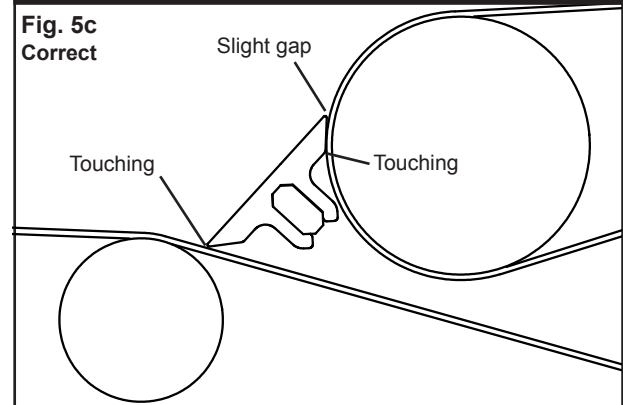
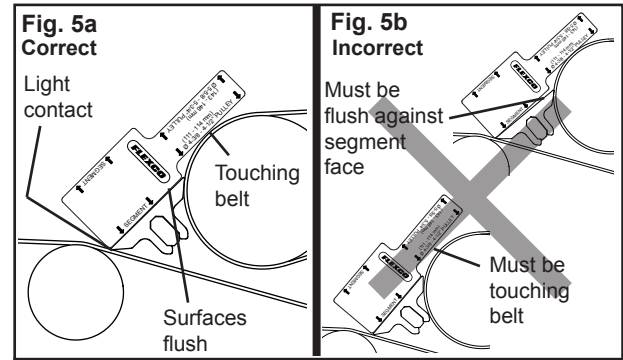
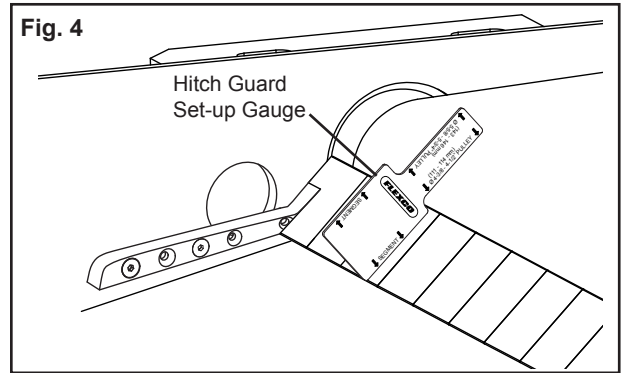
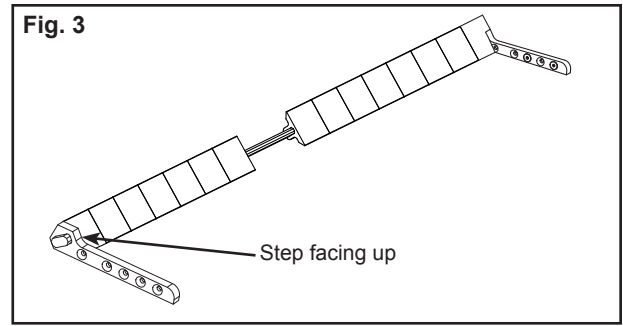

14. Insert 5/32" hex key in cap screw on inside of conveyor panel (Fig. 7a) while tightening 1/4-20 Nylok nut on outside of conveyor panel with 7/16" open-end wrench (or socket and ratchet drive) (Fig 7b).

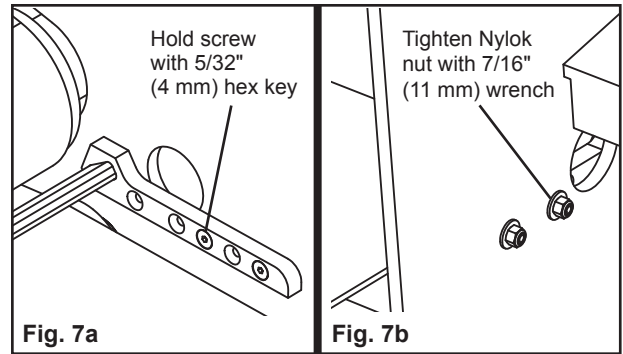

15. With a soft-faced mallet, tap right and left end segments onto support bar with notches nesting around mounting plate steps (Fig. 8). Install remaining center segments.

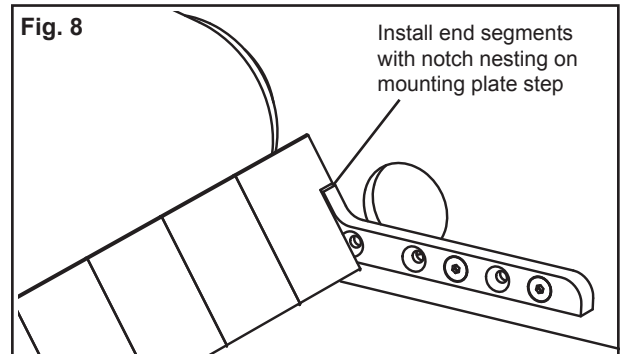

16. **NOTE:** An exact number of segments may not fill the support bar. At the remaining unfilled segment location tightly push segments in opposite directions. Measure the "Max Width" of the gap (Fig. 9).

17. If MAX WIDTH is greater than 1.5" (38 mm), use table saw to cut a final segment to 1/16"-1/8" (1.5-3 mm) less than MAX WIDTH.

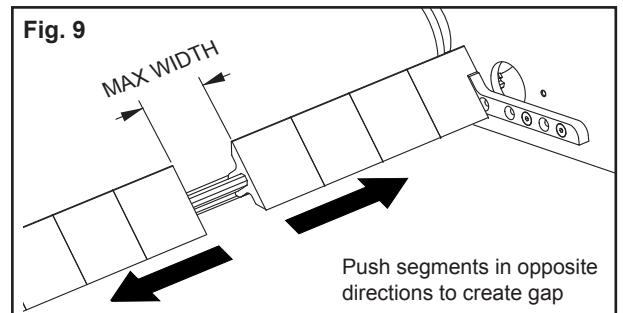

18. If MAX WIDTH is less than 1.5" (38 mm):

- Remove one additional segment adjacent to gap (Fig. 10).
- Measure MAX WIDTH opening and divide by 2. ( $X / 2$ )
- Using table saw, cut two final segments 1/32" - 1/16" (.8 - 1.5 mm) less than dimension in Step b above.

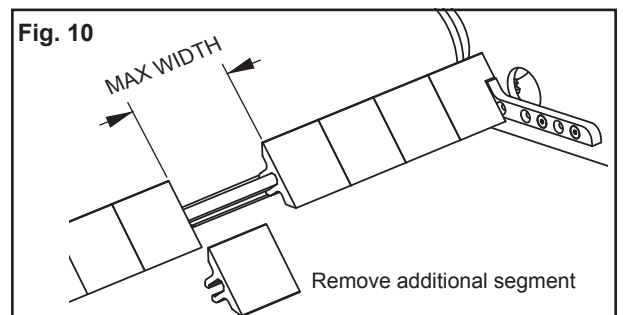

19. Install modified final segment(s), and then move all segments across support bar so they are tightly positioned together with total gap of 1/16"-1/8" (1.5-3 mm) between one end segment and mounting plate. This will provide clearance for possible thermal expansion of segments (Fig.11).

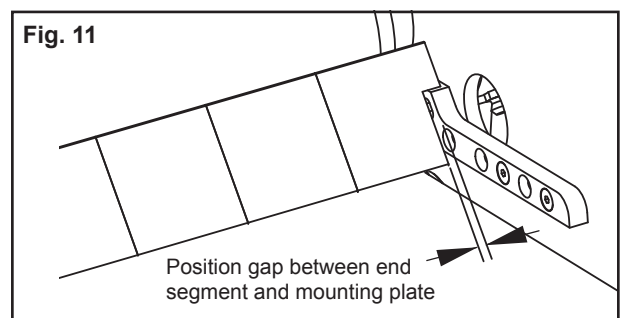

2525 Wisconsin Avenue • Downers Grove, IL 60515-4200 • USA  
Tel: (630) 971-0150 • Fax: (630) 971-1180 • E-mail: [info@flexco.com](mailto:info@flexco.com)

Visit [www.flexco.com](http://www.flexco.com) for other Flexco locations and products.

©2021 Flexible Steel Lacing Company, 11/17/21. For reorder: X2927

