

P-Type® Secondary Cleaner

Installation, Operation and Maintenance Manual

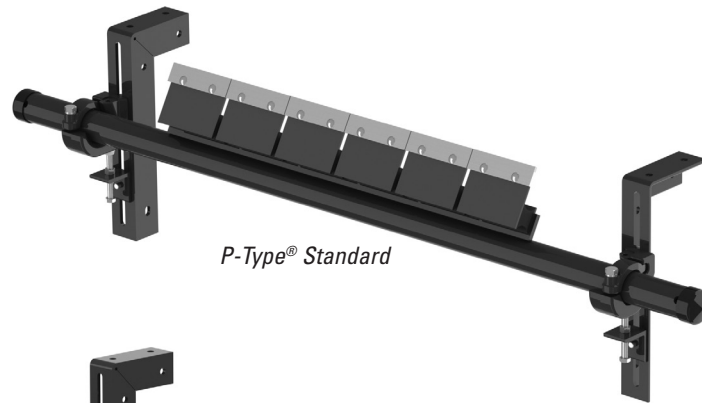

P-Type® Standard

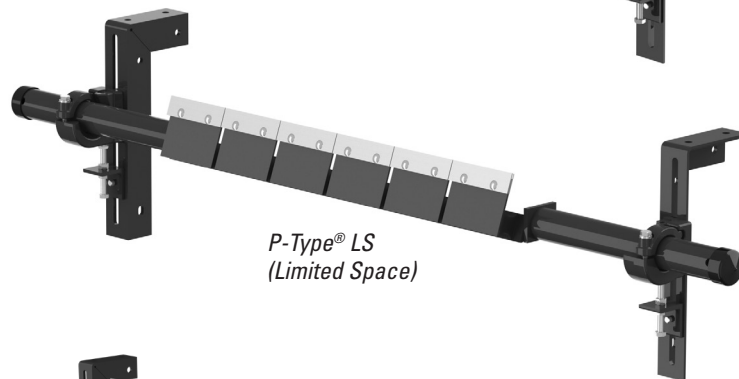

*P-Type® LS
(Limited Space)*

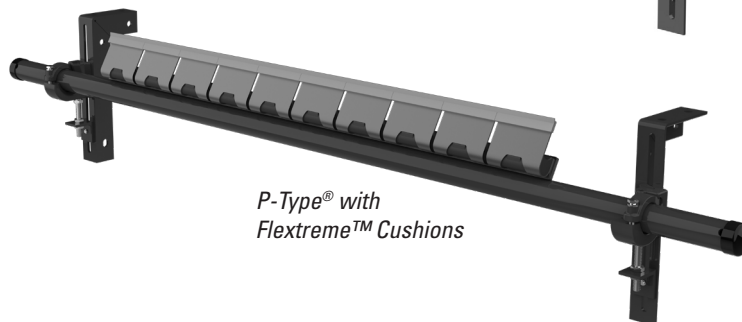

*P-Type® with
Flextreme™ Cushions*

P-Type® Secondary Cleaner

Serial Number: _____
Purchase Date: _____
Purchased From: _____
Installation Date: _____

Serial number information can be found on the Serial Number Label included in the Information Packet found in the cleaner carton.

This information will be helpful for any future inquiries or questions about belt cleaner replacement parts, specifications or troubleshooting.

Table of Contents

Section 1 - Important Information	4
1.1 General Introduction	4
1.2 User Benefits	4
Section 2 - Safety Considerations and Precautions	5
2.1 Stationary Conveyors.....	5
2.2 Operating Conveyors.....	5
Section 3 - Pre-Installation Checks and Options	6
3.1 Checklist	6
3.2 Optional Installation Accessories.....	6
Section 4 - Installation Instructions	7
4.1 P-Type®/ P-Type®LS.....	7
Section 5 - Pre-Operation Checklist and Testing	10
5.1 Pre-Op Checklist	10
5.2 Test Run the Conveyor	10
Section 6 - Maintenance	11
6.1 New Installation Inspection	11
6.2 Routine Visual Inspection.....	11
6.3 Routine Physical Inspection	11
6.4 Blade Replacement Instructions.....	12
6.5 Maintenance Log	14
6.6 Cleaner Maintenance Checklist.....	15
Section 7 - Troubleshooting	16
Section 8 - Specs and CAD Drawings	17
8.1 Specs and Guidelines	17
8.2 P-Type® with C-Tips.....	18
8.3 P-Type® LS with C-Tips	19
Section 9 - Replacement Parts	20
Section 10 - Other Flexco Conveyor Products	21

Section 1 – Important Information

1.1 General Introduction

We at Flexco are very pleased that you have selected a P-Type® Secondary Cleaner for your conveyor system.

This manual will help you to understand the operation of this product and assist you in making it work up to its maximum efficiency over its lifetime of service.

It is essential for safe and efficient operation that the information and guidelines presented be properly understood and implemented. This manual will provide safety precautions, installation instructions, maintenance procedures and troubleshooting tips.

If, however, you have any questions or problems that are not covered, please visit our web site or contact our Customer Service Department.

Visit www.flexco.com for other Flexco locations and products.

Please read this manual thoroughly and pass it on to any others who will be directly responsible for installation, operation and maintenance of this product. While we have tried to make the installation and service tasks as easy and simple as possible, **it does however require correct installation and regular inspections and adjustments to maintain top working condition.**

1.2 User Benefits

Correct installation and regular maintenance will provide the following benefits for your operation:

- Reduced conveyor downtime
- Reduced man-hour labour
- Lower maintenance budget costs
- Increased service life for the belt cleaner and other conveyor components

Section 2 – Safety Considerations and Precautions

Before installing and operating the P-Type® Secondary Cleaner, it is important to review and understand the following safety information.

There are set-up, maintenance and operational activities involving both **stationary** and **operating** conveyors. Each case has a safety protocol.

2.1 Stationary Conveyors

The following activities are performed on stationary conveyors:

- Installation
- Blade replacement
- Repairs
- Tension adjustments
- Cleaning

DANGER

It is imperative that local Lockout/Tagout (LOTO) regulations be followed before undertaking the preceding activities. Failure to use LOTO exposes workers to uncontrolled behaviour of the belt cleaner caused by movement of the conveyor belt. Severe injury or death can result.

Before working:

- Lockout/Tagout the conveyor power source
- Disengage any takeups
- Clear the conveyor belt or clamp securely in place

WARNING

Use Personal Protective Equipment (PPE):

- Safety eyewear
- Hardhats
- Safety footwear

Close quarters, springs and heavy components create a worksite that compromises a worker's eyes, feet and skull.

PPE must be worn to control the foreseeable hazards associated with conveyor belt cleaners. Serious injuries can be avoided.

2.2 Operating Conveyors

There are two routine tasks that must be performed while the conveyor is running:

- Inspection of the cleaning performance
- Dynamic troubleshooting

DANGER

Every belt cleaner is an in-running nip hazard. Never touch or prod an operating cleaner. Cleaner hazards may cause instantaneous amputation and entrapment.

WARNING

Belt cleaners can become projectile hazards. Stay as far from the cleaner as practical and use safety eyewear and headgear. Missiles can inflict serious injury.

WARNING

Never adjust anything on an operating cleaner. Unforeseeable belt projections and tears can catch on cleaners and cause violent movements of the cleaner structure. Flailing hardware can cause serious injury or death.

Section 3 – Pre-installation Checks and Options

3.1 Checklist

- Check that the cleaner size is correct for the beltline width.
- Check the belt cleaner carton and make sure all the parts are included.
- Review the “Tools Needed” list on the top of the installation instructions.
- Check the conveyor site:
 - Will the cleaner be installed on a chute?
 - Is the install on an open head pulley requiring mounting structure? (see 3.2 - Optional Installation Accessories)

3.2 Optional Installation Accessories

Pole extenders are also available for wide, non-standard conveyor structures.

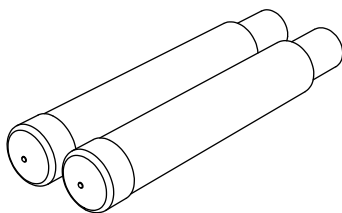

Pole Extender Kit (incl. 2 pole extenders) (Item Code: 76024)

- For cleaner sizes 1800 mm (72") and larger
- Provides 750 mm (30") of extended pole length

Optional Mounting Kits (includes 2 brackets/bars)

DESCRIPTION	ORDERING NUMBER	ITEM CODE	WT. KG
Pole Extender Kit	MAPEK	76024	9.9

*Hardware Included
Lead time: 1 working day

Section 4 – Installation Instructions

4.1 P-Type®/P-Type® LS

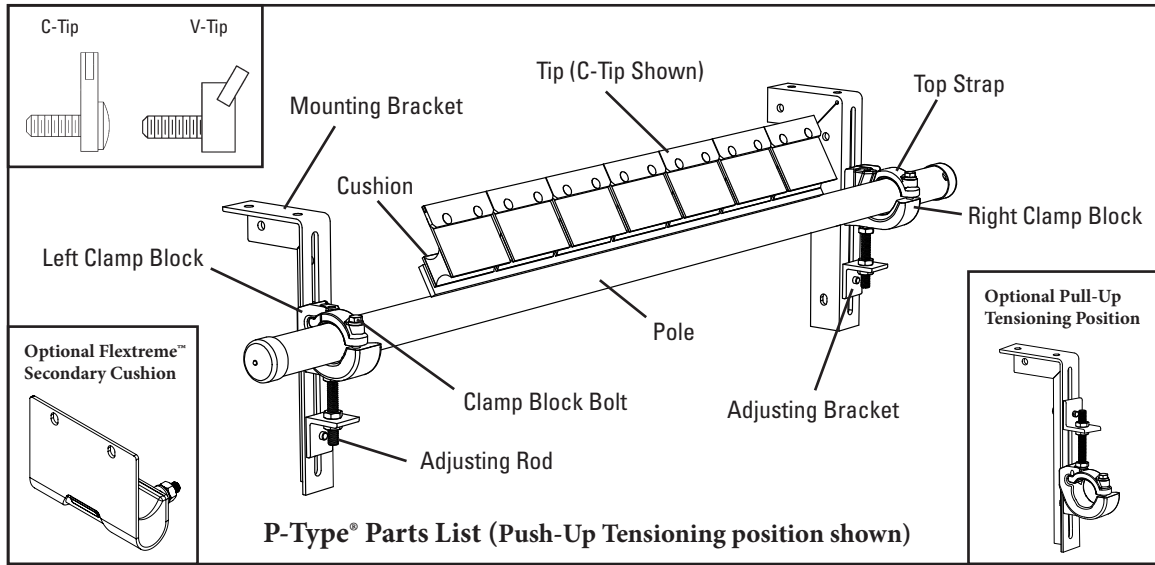

Physically lock out and tag the conveyor at the power source before you begin cleaner installation.

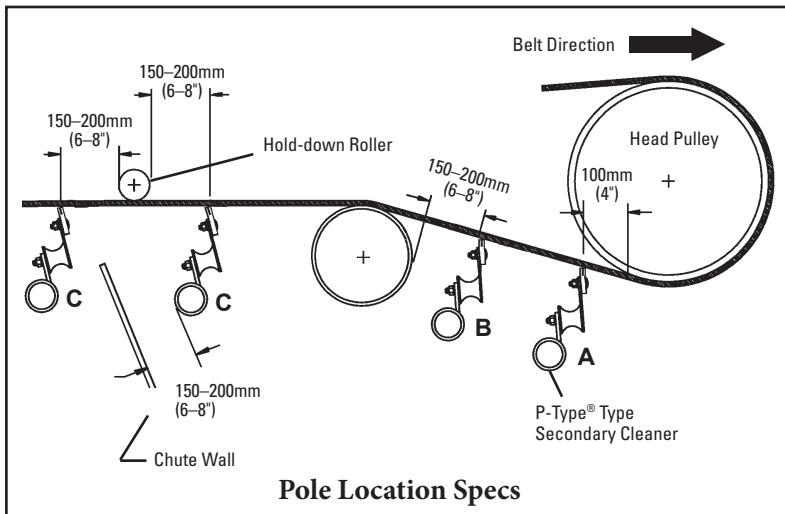

- Tools Needed:**
- 19 mm (3/4") Wrench
 - Ratchet with 19 mm (3/4") Socket
 - 150 mm (6") C-Clamps (x2)
 - Torch (as needed)
 - Welder (as needed)
 - Tape Measure
 - Marking Pen or Soapstone

Before You Begin:

- Double check the tip style needed for your application:
 C-Tip - for mechanically spliced and vulcanized belts.
 V-Tip - for vulcanized belts only.
- For chute mounting it may be necessary to cut an access hole to allow for installation and inspections. (See dimensions in step 2.)
- Follow all safety precautions when using a cutting torch.
- If welding, protect all fastener threads from weld spatter.

Clearance Requirements for Installation

Cleaner	Vertical	Horizontal
P-Type Cleaner	240 mm (10")	100 mm (4")
P-Type LS Cleaner	155 mm (6")	135 mm (5-1/2")

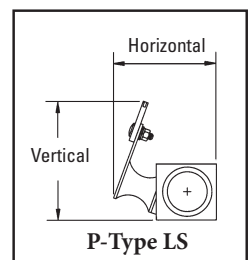
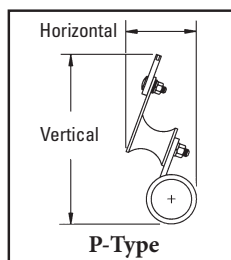

Section 4 – Installation Instructions

4.1 P-Type®/P-Type® LS

1. Install mounting brackets.

Determine the correct clamp block (left or right) and bracket needed for each side of the conveyor (Fig. 1 & 1a). The top strap should be offset away from the belt (you should be able to see the notch for the top strap from the outside of the conveyor).

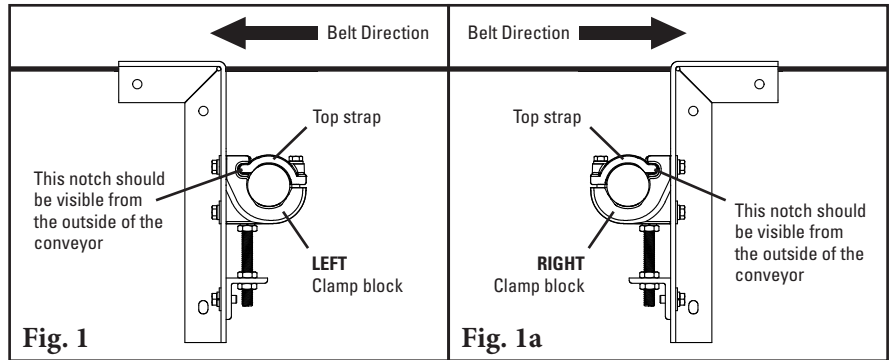

For chute mounting: For a chute installation a belt location line must first be established. Draw a line on the chute replicating this location. If head pulley and snub pulley are close, it may be necessary to assume an approximate belt line between the two. In the determined location draw a line perpendicular to the belt line. Make a mark on this line 175 mm (7") (138 mm (5-1/2") for PLS) below belt location line (Fig. 1b).

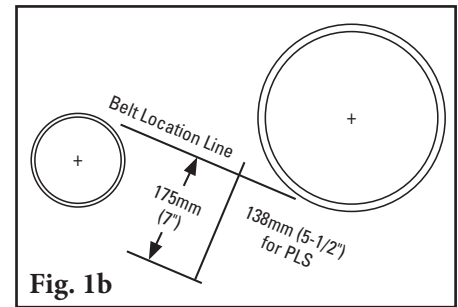

Locate a mounting bracket along the belt location line (Fig. 1b), allowing the centreline of the clamp block to align with the 175 mm (7") (138 mm (5-1/2") for PLS) mark (Fig. 1c). To move the clamp blocks, if necessary, loosen the clamp block lock bolts and the adjusting bracket lock bolt and move the clamp block to a position where the centre of the hole is 175mm (7") (138 mm (5-1/2") for PLS) below the bottom of the belt. Bolt or weld in place. Repeat this step on the opposite side. On one side an access hole may be required (Fig. 1d).

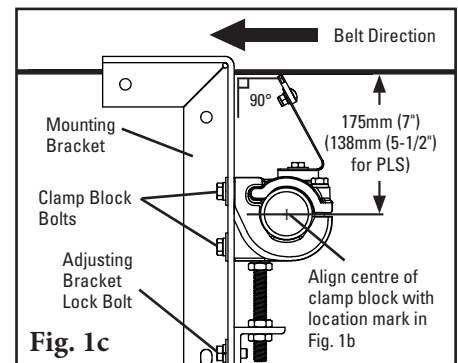

NOTE: The mounting brackets must be aligned perpendicular to the belt.

For structure mounting: In most applications the standard mounting brackets will have adequate room to fit on the structure with no cutting. Clamp the mounting bracket into position (use 150 mm (6") clamps). Move the clamp block to align the centre of the block with a point 175 mm (7") (138 mm (5-1/2") for PLS) below the belt (Fig. 1e). To move the clamp blocks, if necessary, loosen the clamp block lock bolts and the adjusting bracket lock bolt and turn the adjusting bolt jam nuts. The bracket can now be bolted or welded in place. Locate and install bracket on the opposite side of belt in alignment with the first bracket.

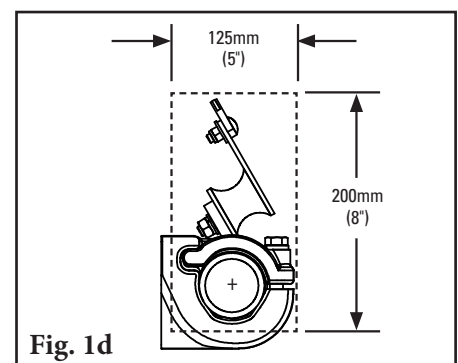

NOTE: The brackets must be aligned perpendicular to the belt.

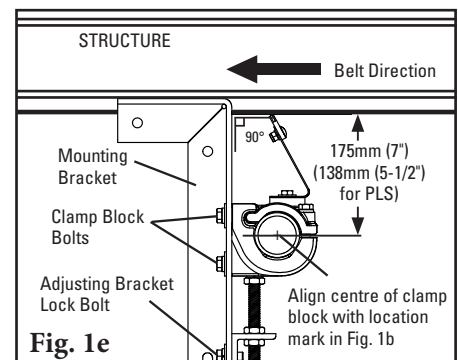

Section 4 – Installation Instructions

4.1 P-Type®/P-Type® LS

- 2. Choose the tensioner position.** The tensioner is shipped mounted in the push-up position. Depending upon the space constraints of the installation, the tensioner can be optionally mounted in a pull-up position. To do this, loosen the threaded rod lock nut, unscrew the threaded rod and remove adjusting bracket lock bolt. Then move the adjusting bracket and threaded rod to the top of the clamp blocks (Fig. 2) and tighten threaded rod lock nut.
- 3. Install the pole.** Remove the clamp block top strap on the access side of the conveyor, and on the opposite side loosen the clamp block bolt. Slide the pole across and into the loosened clamp block, place near end of pole in bottom section of clamp block (Fig. 3). Replace the top strap on the clamp block, centre the blades on the belt and tighten both clamp block bolts finger tight.
- 4. Set the tip angle.** With angle gauge provided, rotate the tips to the preset angle (Fig. 4) and lock the pole in place by tightening the clamp block bolts equally.

NOTE: Make sure there is NO tip-to-belt contact while making this alignment. If contact occurs, lower the pole by loosening the clamp block lock bolts and raising the top adjusting bolt jam nut (Fig. 4). When the tips are not touching the belt, repeat this step.

- 5. Set the tip tension.** With all of the clamp block lock bolts slightly loosened, back down the bottom adjusting bolt jam nut 4–5 turns on both sides (Fig. 5). Turn the top adjusting bolt jam nuts down until light contact is made between the tips and belt across the entire width of the cleaner. Give an additional 1 turn (6 flats) to both of the top adjusting bolt jam nuts and tighten both of the bottom adjusting bolt jam nuts. Tighten all clamp block lock bolts. Double check that all bolts and nuts on the cleaner are tight.

NOTE: Add (or reduce) tension by making 1/4-turns (3 flats) adjustments on the adjustment bolt until the correct tip contact is obtained.

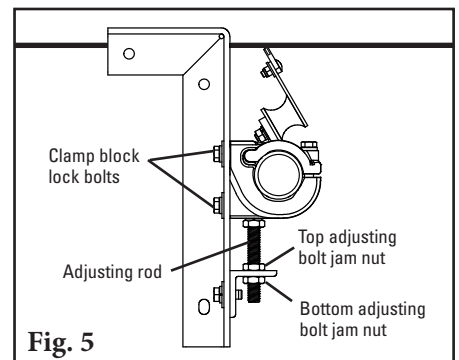
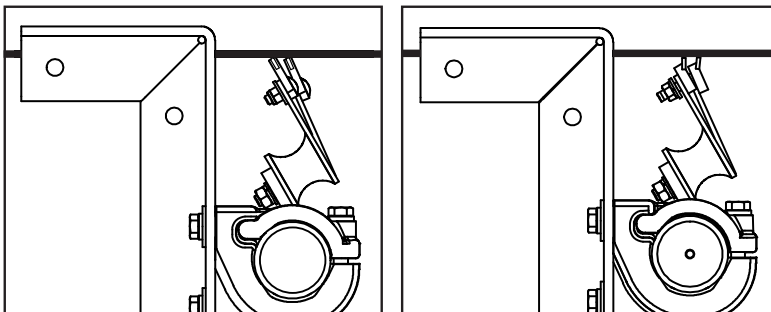
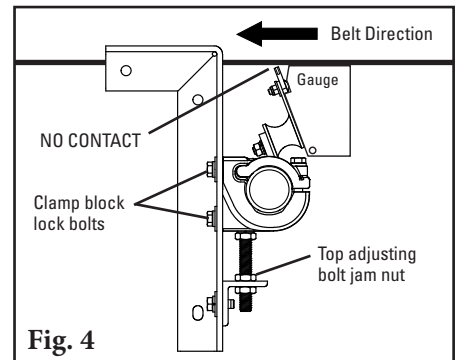
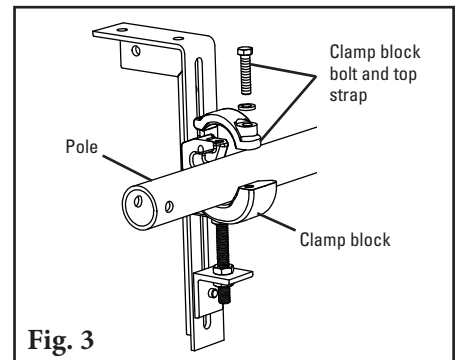
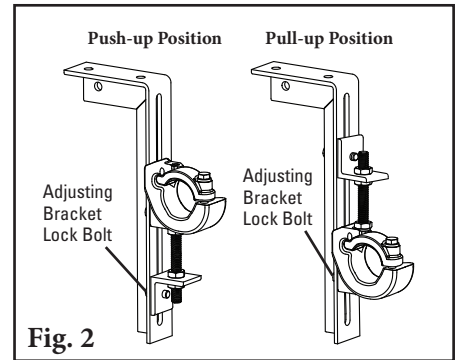

Section 5 – Pre-Operation Checklist and Testing

5.1 Pre-Op Checklist

- Recheck that all fasteners are tightened properly.
- Add pole caps.
- Apply all supplied labels to the cleaner.
- Check the blade location on the belt.
- Be sure that all installation materials and tools have been removed from the belt and the conveyor area.

5.2 Test Run the Conveyor

- Run the conveyor for at least 15 minutes and inspect the cleaning performance.
- Check the tensioner spring for recommended length (proper tensioning).
- Make adjustments as necessary.

NOTE: Observing the cleaner when it is running and performing properly will help to detect problems or when adjustments are needed later.

Section 6 – Maintenance

Flexco belt cleaners are designed to operate with minimum maintenance. However, to maintain superior performance some service is required. When the cleaner is installed a regular maintenance program should be set up. This program will ensure that the cleaner operates at optimal efficiency and problems can be identified and fixed before the cleaner stops working.

All safety procedures for inspection of equipment (stationary or operating) must be observed. The P-Type® Secondary Cleaner operates at the discharge end of the conveyor and is in direct contact with the moving belt. Only visual observations can be made while the belt is running. Service tasks can be done only with the conveyor stopped and by observing the correct lockout/tagout procedures.

6.1 New Installation Inspection

After the new cleaner has run for a few days a visual inspection should be made to ensure the cleaner is performing properly. Make adjustments as needed.

6.2 Routine Visual Inspection (every 2–4 weeks)

A visual inspection of the cleaner and belt can determine:

- If adjusting brackets are set for optimal tensioning.
- If the belt looks clean or if there are areas that are dirty.
- If the blade is worn out and needs to be replaced.
- If there is damage to the blade or other cleaner components.
- If fugitive material is built up on the cleaner or in the transfer area.
- If there is cover damage to the belt.
- If there is vibration or bouncing of the cleaner on the belt.
- If a snub pulley is used, a check should be made for material buildup on the pulley.
- Significant signs of carryback.

If any of the above conditions exist, a determination should be made on when the conveyor can be stopped for cleaner maintenance.

6.3 Routine Physical Inspection (every 6–8 weeks)

When the conveyor is not in operation and properly locked and tagged out a physical inspection of the cleaner to perform the following tasks:

- Clean material buildup off of the cleaner blade and pole.
- Closely inspect the blade for wear and any damage. Replace if needed.
- Ensure full blade to belt contact.
- Inspect the cleaner pole for damage.
- Inspect all fasteners for tightness and wear. Tighten or replace as needed.
- Replace any worn or damaged components.
- Check the tension of the cleaner blade to the belt. Adjust the tension if necessary using the steps on page 9.
- When maintenance tasks are completed, test run the conveyor to ensure the cleaner is performing properly.

Section 6 – Maintenance

6.4 Blade Replacement Instructions

Physically lock out and tag the conveyor at the power source before you begin cleaner installation.

1. Release the blade tension and remove worn blade tips.
 - a. Loosen the top adjusting bolt jam nuts 25 mm (1") on the top of the adjusting brackets (Fig. 1a).
 - b. Loosen the clamp block lock bolts on both sides and allow the pole to move down and rest on the raised top adjusting bolt jam nuts (Fig. 1b).
 - c. Place location marks across the mounting bracket and the clamp block for quick positioning after blade replacement (Fig. 1c).
 - d. Remove the clamp block lock bolts and adjusting bracket lock bolts on each side and remove the pole with the clamp blocks and adjusting brackets attached (Fig. 1d).
 - e. Remove the nuts, flat washers and lock washers from the tips and remove worn tips (Fig. 1e).
 - f. Insert new blade tips and install flat washers, lock washers and nuts finger tight. Buff the outside corners of the last tip on each side of the cleaner (Fig. 1f).

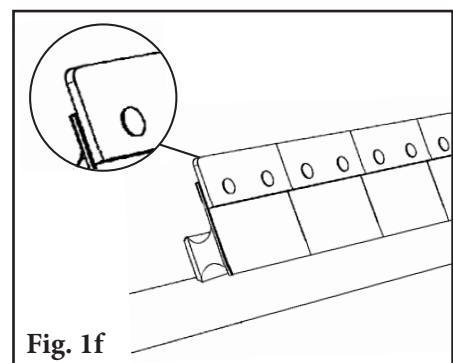
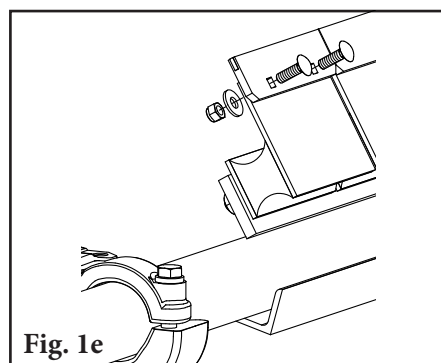
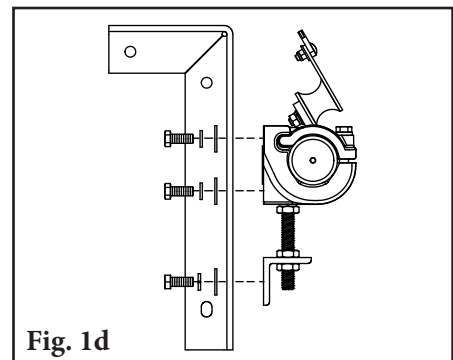
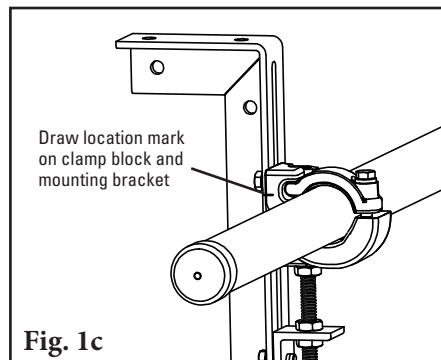
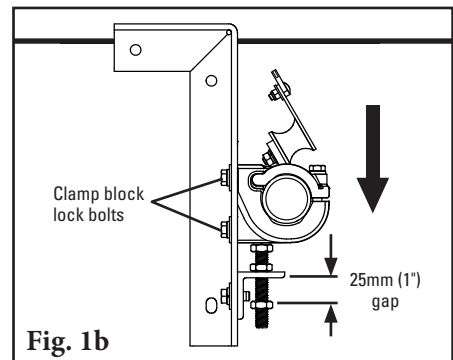
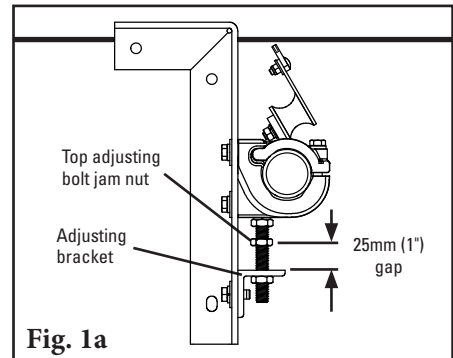

Section 6 – Maintenance

6.4 Blade Replacement Instructions

- Align the blade tips.** Push tips together so there is no more than a .25 mm–.38 mm (.010–.015") gap between them. Position a straightedge along the top surface of new blade tips. Pull upward on each blade to align with the bottom of the straightedge and tighten the nuts (Fig. 2).
- Reinstall the pole.** Slide the pole back into position on the mounting brackets, aligning marks made on the bracket and the clamp block. Install the two adjusting bracket lock bolts and tighten. Install the four clamp block lock bolts finger tight (Fig. 3).
- Set the blade tension.** Turn the top adjusting bolt jam nuts down until light tip to belt contact is made across the entire width of the cleaner. Add an additional 1 turn on the top adjusting bolt jam nuts and lock the bottom adjusting bolt jam nuts. Tighten all clamp block lock bolts.

NOTE: If the belt is cupped, do not overtension the blades to contact the belt. A hold-down roller should be installed to flatten the belt (Fig. 4 & 4a). (Try the Stabilizing Return Roller or Stabilizing Roller Bracket Kit.)

Test run cleaner and inspect operation. If vibration occurs, increase tip tension by making 1/4-turn (3 flats) adjustments.

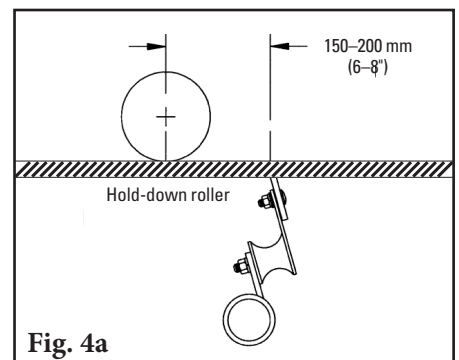
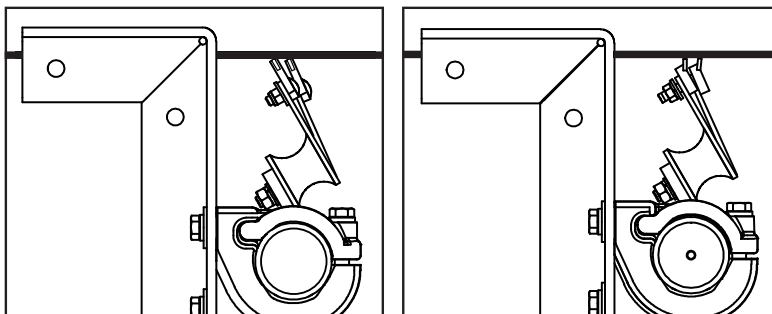
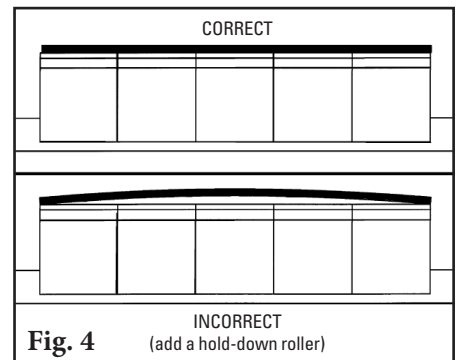
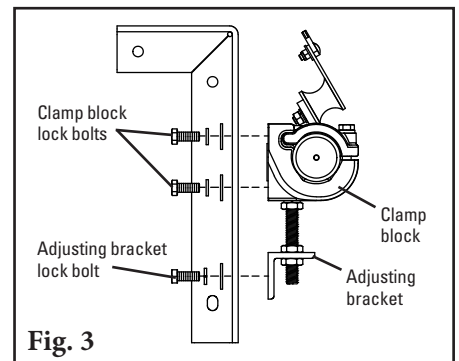
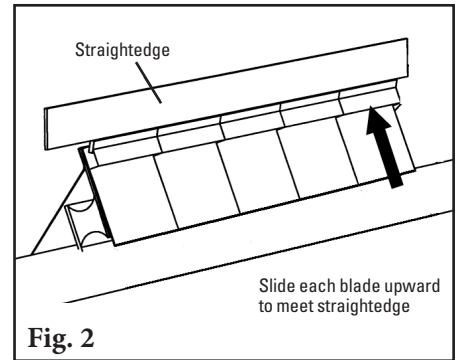

Section 6 – Maintenance

6.5 Maintenance Log

Conveyor Name/No. _____

Date: _____ Work done by: _____ Service Quote #: _____

Activity: _____

Date: _____ Work done by: _____ Service Quote #: _____

Activity: _____

Date: _____ Work done by: _____ Service Quote #: _____

Activity: _____

Date: _____ Work done by: _____ Service Quote #: _____

Activity: _____

Date: _____ Work done by: _____ Service Quote #: _____

Activity: _____

Date: _____ Work done by: _____ Service Quote #: _____

Activity: _____

Date: _____ Work done by: _____ Service Quote #: _____

Activity: _____

Date: _____ Work done by: _____ Service Quote #: _____

Activity: _____

Section 6 – Maintenance

6.6 Cleaner Maintenance Checklist

Site: _____ Inspected by: _____ Date: _____

Belt Cleaner: _____ Serial Number: _____

Beltline Information:

Beltline Number: _____ Belt Condition: _____

Belt Width: 450mm (18") 600mm (24") 750mm (30") 900mm (36") 1050mm (42") 1200mm (48") 1350mm (54") 1500mm (60") 1800mm (72")

Head Pulley Diameter (Belt & Lagging): _____ Belt Speed: _____ m/sec Belt Thickness: _____

Belt Splice: _____ Condition of Splice: _____ Number of Splices: _____ Skived Unskived

Material conveyed: _____

Days per week run: _____ Hours per day run: _____

Blade Life:

Date blade installed: _____ Date blade inspected: _____ Estimated blade life: _____

Is blade making complete contact with belt? Yes No

Blade wear: Left _____ Middle _____ Right _____

Blade condition: Good Grooved Smiled Not contacting belt Damaged

Measurement of spring: Required _____ Currently _____

Was Cleaner Adjusted: Yes No

Pole Condition: Good Bent Worn

Lagging: Side Lag Ceramic Rubber Other None

Condition of lagging: Good Bad Other _____

Cleaner's Overall Performance: (Rate the following 1 - 5, 1= very poor - 5 = very good)

Appearance: Comments: _____

Location: Comments: _____

Maintenance: Comments: _____

Performance: Comments: _____

Other comments: _____



Section 7 – Troubleshooting

Problem	Possible Cause	Possible Solutions
Vibration	Cleaner secure bolts not set	Ensure all locking nuts are tight (Loctite)
	Cleaner not set up correctly	Ensure cleaner set up properly (check tip angle with gauge)
	Belt tension too high	Ensure cleaner can conform to belt, or replace with alternate Flexco secondary cleaner
	Belt flap	Introduce hold-down roller to flatten belt
	Cleaner over-tensioned	Ensure cleaner is correctly tensioned
	Cleaner under-tensioned	Ensure cleaner is correctly tensioned
Material buildup on cleaner	Cleaner not set up correctly	Ensure cleaner set up properly (check tip angle with gauge)
	Buildup on chute	Ensure cleaner is not located too close to back of chute, allowing buildup
	Cleaner being overburdened	Introduce Flexco precleaner
	Excessive sticky material	Frequently clean unit of buildup
Damaged belt cover	Cleaner over-tensioned	Ensure cleaner is correctly tensioned
	Cleaner blade damage	Check blade for wear, damage and chips, replace where necessary
	Attack angle not correct	Ensure cleaner set up properly (check tip angle with gauge)
	Material buildup in chute	Frequently clean unit of buildup
Cleaner not conforming to belt	Cleaner not set up correctly	Ensure cleaner set up properly (check tip angle with gauge)
	Belt tension too high	Ensure cleaner can conform to belt, introduce hold-down roller, or replace with alternate Flexco secondary cleaner
	Belt flap	Introduce hold-down roller to flatten belt
	Cleaner cannot conform	Ensure cleaner can conform to belt, introduce hold-down roller, or replace with alternate Flexco secondary cleaner
Material passing cleaner	Cleaner not set up correctly	Ensure cleaner set up properly (check tip angle with gauge)
	Cleaner tension too low	Ensure cleaner is correctly tensioned
	Cleaner blade worn/damaged	Check blade for wear, damage and chips, replace where necessary
	Cleaner being overburdened	Introduce Flexco precleaner
	Belt flap	Introduce hold-down roller to flatten belt
	Belt worn or grooved	Introduce water spray pole
	Cleaner cannot conform	Ensure cleaner can conform to belt, introduce hold-down roller, or replace with alternate Flexco secondary cleaner
Damage to mechanical fastener	Incorrect cleaner blade selection	Change blade type to accommodate fastener style (C-Tip or V-Tip)
	Belt not skived correctly	Spot and redo splice correctly, lowering the profile flush or below belt surface
	Blade angle incorrect	Reset with gauge
Missing material in belt centre only	Cupped Belt	Install hold-down roller and reset blade angle with gauge
	Cleaner blade worn/damaged	Check blade for wear, damage and chips, replace where necessary
Missing material on outer edges only	Cupped Belt	Install hold-down roller and reset blade angle with gauge
	Cleaner blade worn/damaged	Check blade for wear, damage and chips, replace where necessary

Section 8 – Specifications and CAD Drawings

8.1 Specifications and Guidelines

Pole Length Specifications

CLEANER SIZE		MAX OVERALL POLE LENGTH		MAXIMUM CONVEYOR SPAN	
mm	in.	mm	in.	mm	in.
450	18	1200	48	1075	43
600	24	1350	54	1225	49
750	30	1500	60	1375	55
900	36	1650	66	1525	61
1050	42	1800	72	1675	67
1200	48	1950	78	1825	73
1350	54	2200	88	2075	83
1500	60	2350	94	2225	89
1800	72	2650	106	2525	101

Pole Diameter - 60 mm (2-3/8")

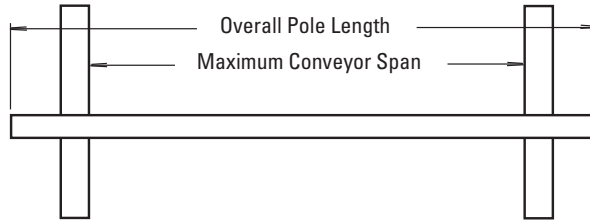

Clearance Guidelines for Installation

CLEANER TYPE	BELT WIDTH/ CLEANER SIZE		HORIZONTAL CLEARANCE REQUIRED		VERTICAL CLEARANCE REQUIRED	
	mm	in.	mm	in.	mm	in.
P-Type	450-1800	18-72	100	4	240	10
P-Type LS	450-1350	18-54	135	5-1/2	155	6

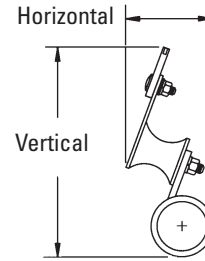

P-Type

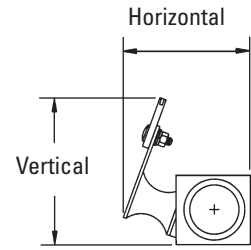

P-Type LS

P-Type Cushion Specifications

CUSHION	DUROMETER	TEMPERATURE RANGE
Standard	55A	-35 to 82°C (-30 to 180°F)
Neoprene	55A	-20 to 110°C (-4 to 230°F)

Specifications:

- Maximum Belt Speed5M/sec (1000 FPM)
- Temperature Rating-35 to 82°C (-30 to 180°F)
- Usable Blade Wear Length9 mm (3/8")
- Blade Materials.....C-Tip: Impact Resistant Tungsten Carbide (works with mechanical fasteners)
V-Tip: Long Life Tungsten Carbide (works on vulcanized belts only)
- Available for Belt Widths.....P-Type: 450 to 1800 mm (18 to 72")
P-Type LS: 450 to 1350 mm (18 to 54")
Other sizes available upon request.
- CEMA Cleaner Rating.....Class 4

Section 9 – Replacement Parts List

9.1 Replacement Parts List

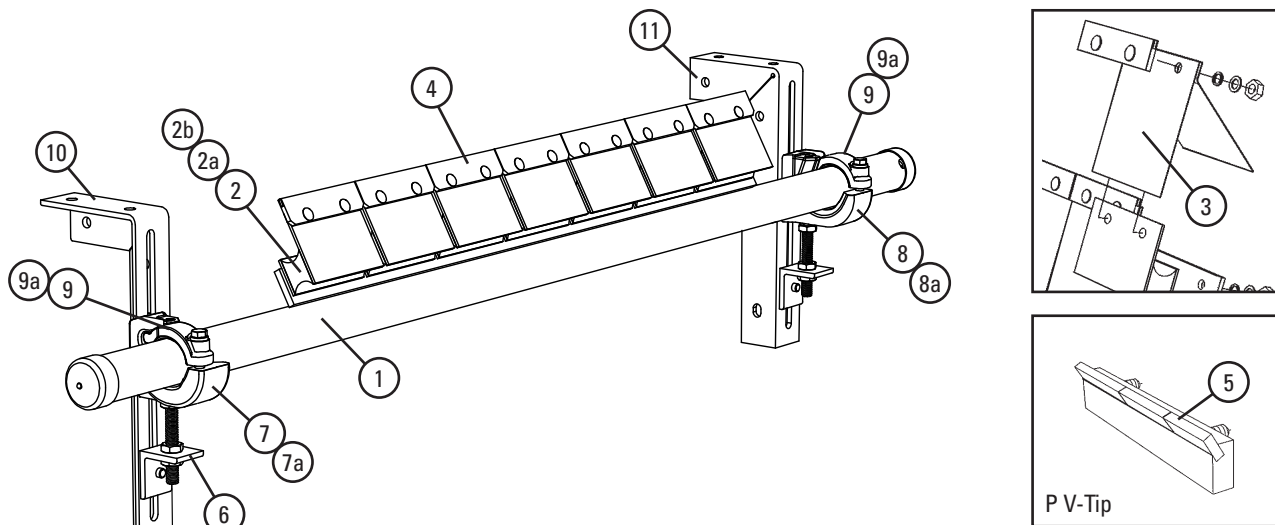

Replacement Parts

REF	DESCRIPTION	BELT WIDTH		POLE LENGTH		POWDER COATED			STAINLESS STEEL		
		mm	in.	mm	in.	ORDERING NUMBER	ITEM CODE	WT. KG	ORDERING NUMBER	ITEM CODE	WT. KG
1	P-Type® Pole 60 mm (2-3/8") Pole Diameter	450	18	1250	50	PP450	73003	10.0	PP450-S/S	75382	10.0
		600	24	1350	54	PP600	73005	11.0	PP600-S/S	75383	11.0
		750	30	1500	60	PP750	73007	13.0	PP750-S/S	75384	13.0
		900	36	1650	66	PP900	73009	15.0	PP900-S/S	75385	15.0
		1050	42	1800	72	PP1050	73011	20.0	PP1050-S/S	75386	21.0
		1200	48	1950	78	PP1200	73013	20.0	PP1200-S/S	75387	23.0
	P-Type Pole 73 mm (2-7/8") Pole Diameter	1400	54	2200	88	PP1400	73015	24.0	PP1400-S/S	75388	25.0
		1500	60	2350	94	PP1500	73016	25.0	PP1500-S/S	75389	26.0
		1800	72	2650	106	PPHD1800	74597	27.0	PPHD1800-S/S	A1781	28.0
		2000	80	2850	114	PPHD2000	74556	31.0	PPHD2000-S/S	A2120	29.0
		2100	84	2950	118	PPHD2100	A2803	38.0	PPHD2100-S/S	A1613	39.0
		2400	96	3250	130	PPHD2400	74557	44.0	PPHD2400-S/S	A1775	45.0
2	P Cushion					PHA	73626	1.0	PHSC-S/S	73433	1.0
2a	Flextreme Cushion (for powder coated, mild steel, and stainless steel cleaners)					PXTC	107137	0.9	PXTC	107137	0.9
2b	P-Type Powerflex Cushion								PFC-P-S/S	79289	1.9
3	P Polysield					PPS6	73024	1.0	PSSS	74773	1.0
-	PU-Tip (Polyurethane Tip for Fastened Belts)					PU150	73020	1.0			
4	C-Tip (for mechanically spliced and vulcanised belts)					CT6	74535	0.4			
5	P V-Tip* (for vulcanised belts only)					PSA150	73156	0.4	PVT6-S/S	75420	0.4
6	Adjusting Bracket Kit* (1ea.)					PAB	75513	0.7	PAB-S/S	75515	0.7
7	Pole Clamp Kit Left* (1ea.) (incl. item 9) for sizes 450–1200 mm (18–48")					CCKL	79224	3.1	CCKL-S/S	79226	3.1
8	Pole Clamp Kit Right* (1ea.) (incl. item 9) for sizes 450–1200 mm (18–48")					CCKR	79228	3.1	CCKR-S/S	79230	3.1
9	Cradle Clamp Top Strap (1ea.) (for use on L or R Pole Clamp Kit)					CCKTS	79232	0.5	CCKTS-S/S	79234	0.5
10	Mounting Bracket Kit Left					PMBL (left)	75516	3.8	PMBL-S/S (left)	75518	3.8
11	Mounting Bracket Kit Right					PMBL (right)	75519	3.8	PMBL-S/S (right)	75521	3.8
-	Cradle Clamp Mounting Kit* (incl. 2 ea. item 6, and 1 ea. Items 7, 8, 10 & 11) for sizes 450–1200 mm (18–48")					CCMK	78919	15.0	CCMK-S/S	78921	15.0
HEAVY-DUTY COMPONENTS											
7a	HD Pole Clamp Kit Left* (1ea.) (incl. item 9a) for sizes 1200–2400mm (48–96")					CCKHDL	79225	4.0	CCKHDL-S/S	79227	4.0
8a	HD Pole Clamp Kit Right* (1ea.) (incl. item 9a) for sizes 1200–2400mm (48–96")					CCKHDR	79229	4.0	CCKHDR-S/S	79231	4.0
9a	HD Cradle Clamp Top Strap (1ea.) (for use on L or R HD Pole Clamp Kit)					CCKHDTS	79233	0.8	CCKHDTS-S/S	73235	0.8
-	HD Cradle Clamp Mounting Kit* (incl. 2 ea. item 6, and 1 ea. Items 7, 8, 10 & 11) for sizes 1200–2400mm (48–96")					CCMKHD	78920	16.7	CCMKHD-S/S	78922	16.7

*Hardware included

Section 10 – Other Flexco Conveyor Products

Flexco provides many conveyor products that help your conveyors to run more efficiently and safely. These components solve typical conveyor problems and improve productivity. Here is a quick overview on just a few of them:

EZP1 Precleaner



- Patented ConShear™ blade renews its cleaning edge as it wears
- Visual Tension Check™ for optimal blade tensioning and simple retensioning
- Quick and easy one-pin blade replacement Material Path Option™ for optimal cleaning and reduced maintenance

Flexco Slider/Impact Beds



- Adjusting troughing angles for easy installation and adjustability
- Long-wearing UHMW for sealing the load zone
- Offered in both Light & Medium duty designs to affordably fit your application

MHS Secondary Cleaner with Service Advantage Cartridge

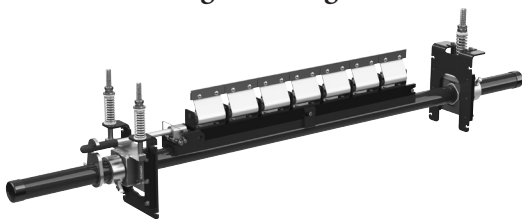

- An easy slide-out cartridge for service
- Cartridge design to speed up blade-change maintenance
- Patented PowerFlex™ Cushions for superior cleaning performance
- Compatible with Flexco mechanical splices

PT Max™ Belt Trainer



- Patented “pivot & tilt” design for superior training action
- Dual sensor rollers on each side to minimise belt damage
- Pivot point guaranteed not to freeze up
- Available for topside and return side belts

Flexco Specialty Belt Cleaners



- “Limited space” cleaners for tight conveyor applications
- High Temp cleaners for severe, high heat applications
- A rubber-fingered cleaner for chevron and raised rib belts
- Multiple cleaner styles in stainless steel for corrosive applications

Belt Ploughs



- A belt cleaner for the tail pulley
- Exclusive blade design quickly spirals debris off the belt
- Economical and easy to service
- Available in vee or diagonal models

Visit www.flexco.com for other Flexco locations and products, or to find an authorised distributor.

©2020 Flexible Steel Lacing Company. 03-04-24. X2859

