

FLEX-LIFTER™

Conveyor Belt Lifter

A Tough, Versatile Beltline Tool

Lifting a tensioned conveyor belt out of the way to do maintenance work is a difficult job. It can be time-consuming and dangerous. The Flex-Lifter™ makes the job safer and easier. It takes on the toughest jobs, like lifting a belt even when it is tensioned up to the stated ratings. This tool is versatile. Adjustable wings make it easy to lift troughed or flat topside belts.

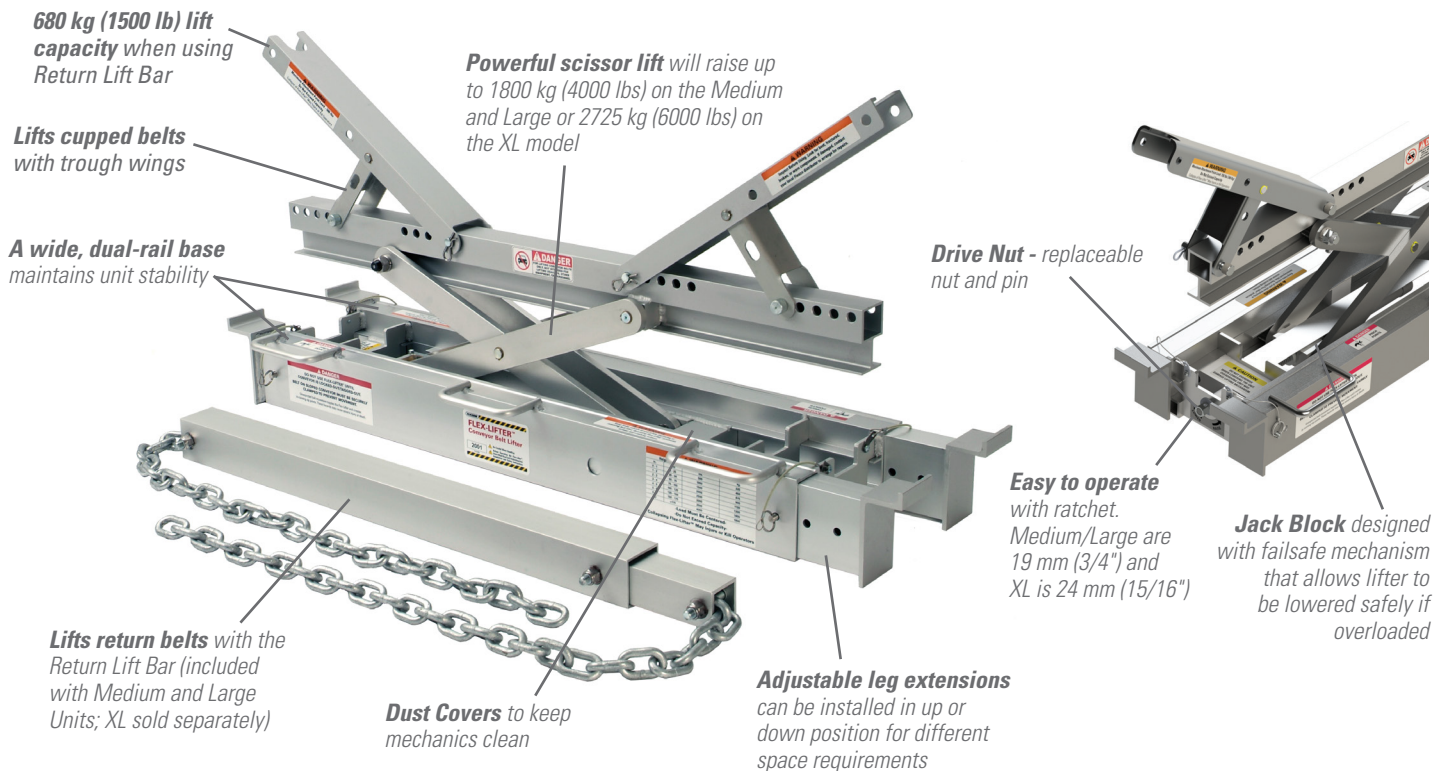

Features and Benefits

- **Easy to use.** The Flex-Lifter™ is easily operated with a manual ratchet. And, if used with caution so as not to overdrive, the Flex-Lifter may be used with a drill motor or impact wrench.
- **Works on a range of conveyors.** The Medium model is for belt widths 900–1500 mm (36–60"), the Large model is for belt widths 1200–1800 mm (48–72"), and the XL model is for belt widths 1800–2400 mm (72–96"). Lifts flat or cupped belts with ease.
- **Safe.** Features a wide, dual-rail base and high lift capacities. Also designed to work with standard CEMA and common underground conveyor structure and idler types.
- **Transportable.** The tool can be carried to the job site and easily placed into position on the conveyor structure. Also available with cart feature for rolling the unit.
- **Won't damage the belt.** Lifts the belt from underneath. Does not clamp onto the belt's edges or cover.

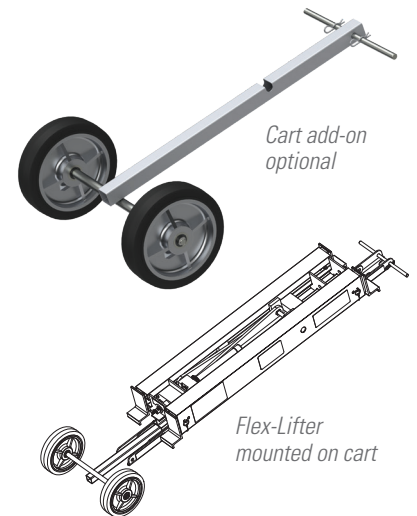

FLEX-LIFTER™ Conveyor Belt Lifter

Specifications and Guidelines

Specifications						
Sizes	Belt Width Range	Conveyor Span		Weight	Closed Height	Vertical Lift
		Min.	Max.			
Medium	900–1500mm (36–60")	1047.8mm (41.25")	1936.8mm (76.25")	29.9 kg (66 lb.)	185mm (7.25")	355mm (14.12")
Large	1200–1800mm (48–72")	1301.8mm (51.25")	2190.8mm (86.25")	35.4 kg (78 lb.)	185mm (7.25")	410mm (16.25")
XL	1800–2400mm (72–96")	1816.1mm (71.50")	2704.3mm (106.47")	58.1 kg (128 lb.)	200mm (7.75")	475mm (18.62")
Return Lift Bar (Medium)	900–1500mm (36–60")	-	-	11.3 kg (25 lb.)	N/A	N/A
Return Lift Bar (Large)	1200–1800mm (48–72")	-	-	22.6 kg (50 lb.)	N/A	N/A
V-Return Lift Bar (XL)	1800–2400mm (72–96")	-	-	28.6 kg (63 lb.)	N/A	N/A

Safe Lifting Capacity (Medium and Large models)			
Height		Max. Weight	
mm	in.	kg	lb.
0–25	0–1	225	500
25–50	1–2	450	1000
50–75	2–3	675	1500
75–100	3–4	900	2000
100–125	4–5	1150	2500
125–150	5–6	1350	3000
150–175	6–7	1600	3500
> 175	> 7	1800	4000

Safe Lifting Capacity (XL model)			
Height		Max. Weight	
mm	in.	kg	lb.
0–25	0–1	500	1100
25–50	1–2	815	1800
50–75	2–3	1140	2500
75–100	3–4	1450	3200
100–125	4–5	1680	3700
125–150	5–6	2090	4600
150–175	6–7	2400	5300
> 175	> 7	2725	6000

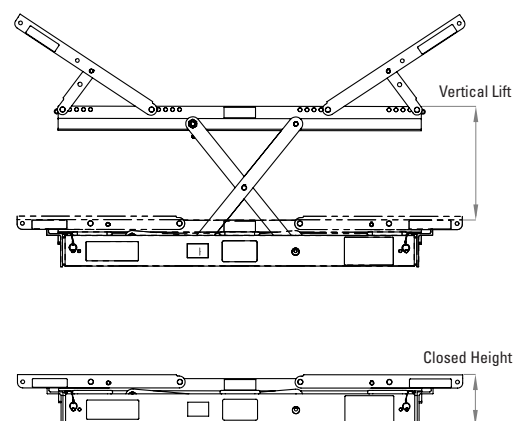

Ordering Information

Flex-Lifter™ Conveyor Belt Lifter			
Description	Ordering Number	Item Code	Wt. Kg
Medium Flex-Lifter™ 900–1500mm (36–60") (incl. return bar)	FL-M	76469	41.3
Large Flex-Lifter 1200–1800mm (48–72") (incl. return bar)	FL-L	76470	58.0
XL Flex-Lifter 1800–2400mm (72–96") (does not incl. return bar)	FL-XL	76983	58.0
Flex-Lifter Cart	FLCK	77729	9.1

Aluminum Content Flex-Lifter		
Aluminum Alloy Type	Percent	
	Mg Magnesium	Ti Titanium
4043	0.05%	0.2%
5356	5.5%	0.2%
6005	0.6%	0.1%
6061	1.0%	–
6063	0.7%	–
7075	2.5%	–



Visit www.flexco.com for other Flexco locations and products, or to find an authorised distributor.

©2019 Flexible Steel Lacing Company. 03-31-25. X2815

