

EZS2 Secondary Cleaner

The Economical, Efficient Belt Cleaning Solution

The EZS2 Secondary Belt Cleaner improves belt cleaning efficiency and reduces routine maintenance tasks. And it does all of this at an affordable price. Add easy, do-it-yourself installation and it makes an unbeatable solution for your conveyor belt cleaning needs.

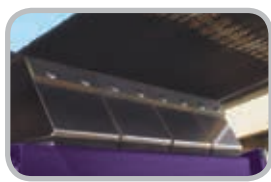

Durable tungsten carbide tips

Segmented blades ensure proper wear throughout the life of the blade



Exclusive FormFlex cushions are independently tensioned and automatically power the blades to the belt

Impact-resistant steel base

Rugged 60mm (2-3/8") diameter pole

Versatile tensioner kit can be mounted to push-up or pull-up the cleaner

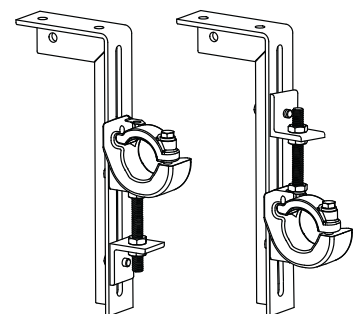

Features and Benefits

- **Cleaning efficiency of metal blades.** The thin, hard edges of the metal blades deliver high cleaning efficiency and long wear life.
- **Works with Flexco mechanical splices.** The tungsten carbide-tipped blades are impact-resistant, and the spring cushion allows them to move away from a passing splice without damage and with minimal cleaning disruption.
- **A complete cleaning system.** When the EZS2 is teamed with the EZP1 Precleaner, the system provides maximum cleaning power for tough applications.
- **Fits most conveyor structures.** Available for belt widths from 450 mm to 1800 mm (18" to 72").

EZS2 Rockline® Secondary Cleaner

Specifications and Guidelines

Maximum Belt Speed

3.5 m/s (700 FPM)

Temperature Rating

-35° C to 93° C (-30° F to 200° F)

Usable Blade Wear Length

9 mm (3/8")

Available for Belt Widths

450 to 1800 mm (18" to 72")

CEMA Cleaner Rating:

Class 3

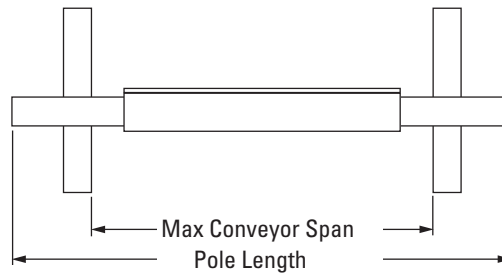

Pole Length

Blade width + 850 mm (34")

Maximum Conveyor Span

Blade width + 725 mm (29")

Ordering Information

EZS2 Secondary			
Belt Width		Ordering Number	Item Code
mm	in.		
450	18	EZS2-450	81119
600	24	EZS2-600	81120
750	30	EZS2-750	81121
900	36	EZS2-900	81122
1050	42	EZS2-1050	81123
1200	48	EZS2-1200	81124
1350	54	EZS2-1350	81125
1500	60	EZS2-1500	81126
1800	72	EZS2-1800	81127

Replacement C-Tips	
Ordering Number	Item Code
ICT6	74535

Tips Required Per Cleaner Size									
mm	450	600	750	900	1050	1200	1350	1500	1800
in.	18	24	30	36	42	48	54	60	72
C-Tips Required	3	4	5	6	7	8	9	10	12

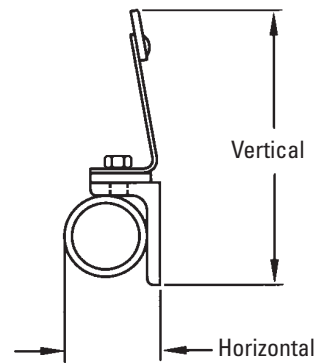

Horizontal Clearance Required

100 mm (4")

Vertical Clearance Required

213 – 238 mm (8-1/2" – 9-1/2")

Additional Information

For high temperature applications up to 204° C (400° F), see the High Temp EZS2 Sell Sheet.



Authorized Distributor:



240 Macpherson Road • #02-01 • Singapore 348574
Tel: +65-6484-1533 • Fax: +65-6484-1531 • E-mail: asiasales@flexco.com

Visit www.flexco.com for other Flexco locations and products.

©2019 Flexible Steel Lacing Company. 07/31/19. For reorder: X2807