

# Pin Replacement for 15004/15005

## Instructions

Pin Description	Quantity	
	15004	15005
3/32" x 3/4"	8	16
3/16" x 1/2"	3	7
3/16" x 3/4"	1	1

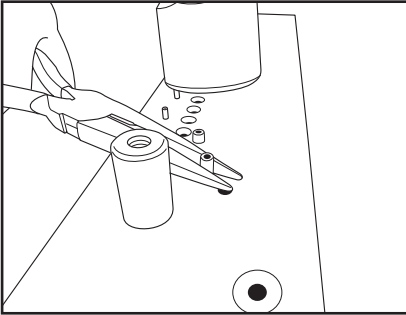

1. Insert 3/16" x 3/4" pin as shown. Hold pin with needle nose pliers. Gently tap pin in place until 1/4" remains above the tool surface.

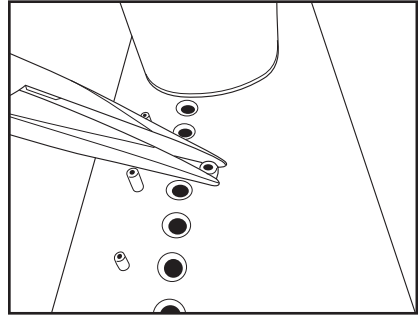

2. Insert 3/16" x 1/2" pin as shown. Hold pin with needle nose pliers. Gently hammer pin until .100" remains above the tool surface. Repeat for all pins this size.

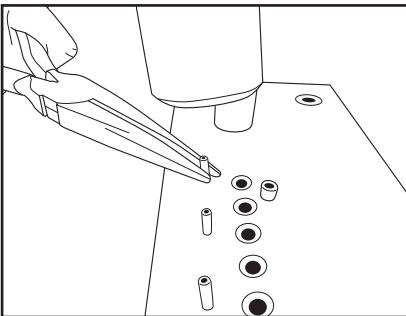

3. Insert 3/32" x 3/4" pins into the proper position as shown. Hold pin with needle nose pliers. Gently tap pin in place until .250" remains above the tool surface. Repeat for all pins this size.



Visit [www.flexco.com](http://www.flexco.com) for other Flexco locations and products, or to find an authorized distributor.

# Pin Replacement for 15004/15005

## Instructions

Pin Description	Quantity	
	15004	15005
3/32" x 3/4"	8	16
3/16" x 1/2"	3	7
3/16" x 3/4"	1	1

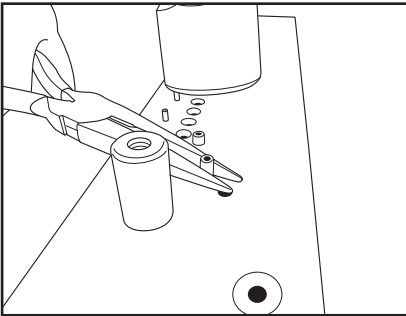

1. Insert 3/16" x 3/4" pin as shown. Hold pin with needle nose pliers. Gently tap pin in place until 1/4" remains above the tool surface.

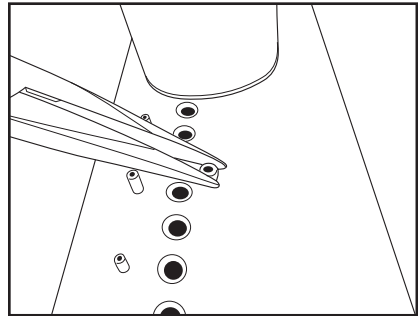

2. Insert 3/16" x 1/2" pin as shown. Hold pin with needle nose pliers. Gently hammer pin until .100" remains above the tool surface. Repeat for all pins this size.

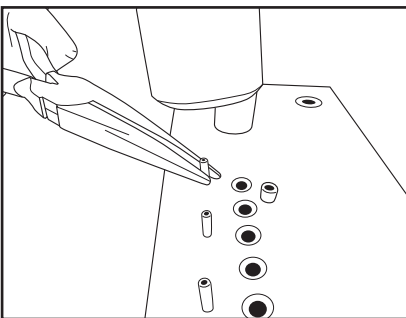

3. Insert 3/32" x 3/4" pins into the proper position as shown. Hold pin with needle nose pliers. Gently tap pin in place until .250" remains above the tool surface. Repeat for all pins this size.



Visit [www.flexco.com](http://www.flexco.com) for other Flexco locations and products, or to find an authorized distributor.