

EZP-LS “Limited Space” Stainless Steel Precleaner with White ConShear™ LS Blade

**Installation, Operation
and Maintenance Manual**



EZP-LS "Limited Space" Stainless Steel Precleaner

with White ConShear™ LS Blade

Serial Number:	_____
Purchase Date:	_____
Purchased From:	_____
Installation Date:	_____

Serial number information can be found on the Serial Number Label included in the Information Packet found in the cleaner carton.

This information will be helpful for any future inquiries or questions about belt cleaner replacement parts, specifications or troubleshooting.

Table of Contents

Section 1 - Important Information	4
1.1 General Introduction.....	4
1.2 User Benefits.....	4
1.3 Service Option.....	4
Section 2 - Safety Considerations and Precautions	5
2.1 Stationary Conveyors.....	5
2.2 Operating Conveyors.....	5
Section 3 - Pre-Installation Checks and Options	6
3.1 Checklist.....	6
3.2 Cleaner Location Adjustments.....	7
3.3 Correct Blade Installation and Tensioning.....	8
Section 4 - Installation Instructions	9
Section 5 - Pre-Operation Checklist and Testing	12
5.1 Pre-Op Checklist.....	12
5.2 Test Run the Conveyor.....	12
Section 6 - Maintenance	13
6.1 New Installation Inspection.....	13
6.2 Routine Visual Inspection.....	13
6.3 Routine Physical Inspection.....	13
6.4 Blade Replacement Inspection.....	14
6.5 Blade Replacement Instructions.....	15
6.6 Maintenance Log.....	17
6.6 Cleaner Maintenance Checklist.....	18
Section 7 - Troubleshooting	19
Section 8 - Specs and CAD Drawings	20
8.1 Specs and Guidelines.....	20
8.2 CAD Drawings.....	21,22
Section 9 - Replacement Parts	23
9.1 Replacement Parts List.....	23
9.2 Replacement Blades for Other OEM Cleaners.....	24
Section 10 - Other Flexco Conveyor Products	25



Section 1 - Important Information

1.1 General Introduction

We at Flexco are very pleased that you have selected the EZP-LS Stainless Steel Precleaner with White ConShear Blade for your conveyor system.

This manual will help you to understand the operation of this product and assist you in making it work up to its maximum efficiency over its lifetime of service.

It is essential for safe and efficient operation that the information and guidelines presented be properly understood and implemented. This manual will provide safety precautions, installation instructions, maintenance procedures and troubleshooting tips.

If, however, you have any questions or problems that are not covered, please visit our web site or contact our Customer Service Department:

Web site: Flexco.com

Customer Service: USA: 1-800-541-8028

Australia: 61-2-9680-3322 • China: 86-21-33528388

England: 44-1274-600-942 • Germany: 49-7428-9406-0

India: 91-44-4354-2091 • Mexico: 52-55-5674-5326

Singapore: 65-6281-7278 • South Africa: 27-11-608-4180

Please read this manual thoroughly and pass it on to any others who will be directly responsible for installation, operation and maintenance of this cleaner. While we have tried to make the installation and service tasks as easy and simple as possible, it does however require correct installation and regular inspections and adjustments to maintain top working condition.

1.2 User Benefits

Correct installation and regular maintenance will provide the following benefits for your operation:

- Reduced conveyor downtime
- Reduced man-hour labor
- Lower maintenance budget costs
- Increased service life for the belt cleaner and other conveyor components

1.3 Service Option

The EZP-LS Stainless Steel Precleaner with White ConShear Blade is designed to be easily installed and serviced by your on-site personnel. However, if you would prefer complete turn-key factory service, please contact your local Flexco Field Engineer or your Flexco Distributor.

Section 2 - Safety Considerations and Precautions

Before installing and operating the EZP-LS Stainless Steel Precleaner with White ConShear Blade, it is important to review and understand the following safety information.

There are set-up, maintenance and operational activities involving both stationary and operating conveyors. Each case has a safety protocol.

2.1 Stationary Conveyors

The following activities are performed on stationary conveyors:

- Installation
- Blade replacement
- Repairs
- Tension adjustments
- Cleaning

DANGER

It is imperative that OSHA/MSHA Lockout/Tagout (LOTO) regulations, 9 CFR 1910.147, be followed before undertaking the preceding activities. Failure to use LOTO exposes workers to uncontrolled behavior of the belt cleaner caused by movement of the conveyor belt. Severe injury or death can result.

Before working:

- Lockout/Tagout the conveyor power source
- Disengage any takeups
- Clear the conveyor belt or clamp securely in place

WARNING

Use Personal Protective Equipment (PPE):

- Safety eyewear
- Hardhats
- Safety footwear

Close quarters, springs and heavy components create a worksite that compromises a worker's eyes, feet and skull.

PPE must be worn to control the foreseeable hazards associated with conveyor belt cleaners. Serious injuries can be avoided.

2.2 Operating Conveyors

There are two routine tasks that must be performed while the conveyor is running:

- Inspection of the cleaning performance
- Dynamic troubleshooting

DANGER

Every belt cleaner is an in-running nip hazard. Never touch or prod an operating cleaner. Cleaner hazards cause instantaneous amputation and entrapment.

WARNING

Belt cleaners can become projectile hazards. Stay as far from the cleaner as practical and use safety eyewear and headgear. Missiles can inflict serious injury.

WARNING

Never adjust anything on an operating cleaner. Unforseeable belt projections and tears can catch on cleaners and cause violent movements of the cleaner structure. Flailing hardware can cause serious injury or death.



Section 3 - Pre-installation Checks and Options

3.1 Checklist

- Check that the cleaner size is correct for the beltline width
- Check the belt cleaner carton and make sure all the parts are included
- Review the “Tools Needed” list on the top of the installation instructions
- Check the conveyor site:
 - Will the cleaner be installed on a chute
 - Is the install on an open head pulley requiring mounting structure (see 3.3 - Optional Installation Accessories)
 - Are there obstructions that may require cleaner location adjustments (see 3.2 - Cleaner Location Adjustments)

3.2 Cleaner Location Adjustments

In certain applications it is necessary to modify the location of the precleaner pole due to permanent obstacles that obstruct the desired location. Relocating the pole location can be done easily and does not hinder the performance of the cleaner as long as the “C” dimension is maintained.

NOTE: In the following example we will be lowering the pole location in the “Y” direction, but the same method could also be applied in the “X” direction.

Conveyor situation:

Pulley Diameter: 12" (300mm)

X=6 1/8" (155mm)

Y=5 1/2" (140mm)

C=8 1/4" (210mm)

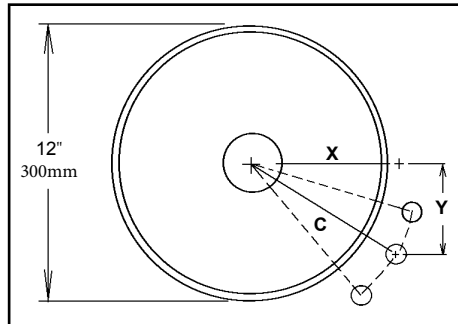

- Determine the given location dimensions and define the change needed.** After laying out the given X & Y dimensions, determine the distance of the modification required for adequate clearance of the pole and tensioning system. (In the example we decide to lower the pole 2" (50mm) to clear the support structure).
- Write down known dimensions.** We can now determine two of the three required dimensions which will allow us to find the third. We know we cannot alter the “C” dimension, so this will remain the same. Also we are required to lower the unit in the “Y” dimension 2" (50mm), so we add 2" (50mm) to the given “Y” dimension.

X = ?"

Y = 5 1/2 + 2 = 7 1/2" (140mm + 50mm = 190mm)

C = 8 1/4" (210mm)

- Determine final dimension.** On a flat vertical surface, using a level, draw one horizontal line and one vertical line, creating a right triangle (Fig 3a). Measure down from the intersection the determined “Y” dimension and mark (Fig 3b). With the tape measure starting at the modified “Y” mark, swing the tape across the “X” line and mark at the “C” dimension where it crosses the “X” line (Fig 3c). Measure from the intersection to the “C” intersection and this will be your new “X” dimension (Fig. 3d).

X = 3 1/2" (89mm)

Y = 7 1/2" (190mm)

C = 8 1/4" (210mm)

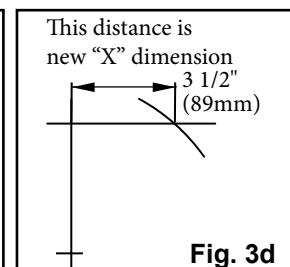
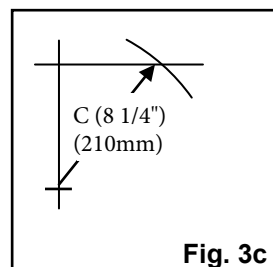
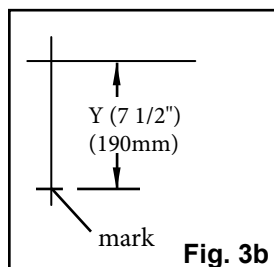
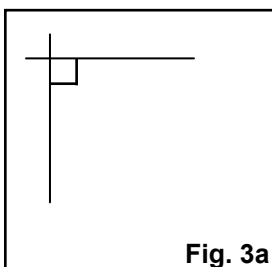

Section 3 - Pre-Installation Checks and Options (cont.)

3.3 Correct Blade Installation and Tensioning

For optimal cleaning efficiency and long wear life, the ConShear™ white blade must be located and tensioned correctly on the belt head pulley. If the cleaner pole is in the wrong location the performance of the new blade may be adversely affected. See “Possible Problems” below. For tensioning, please follow these instructions.

Correct Location:

When blade contact is made against the head pulley (prior to tensioning) there should be a 1/16" to 1/8" (1.5mm to 3mm) gap at the bottom of the blade face (Fig. 1).

Possible Problems:

- Pole location too far out - The initial blade/belt contact gap will be larger than 1/8" (3mm) (Fig. 2). If the blade is correctly tensioned it may flip through before it is fully worn. If tensioned too lightly, it will develop the “smile effect” quickly and not clean properly.
- Pole location too far in - If there is no gap at the initial blade/belt contact (Fig. 3), the tip of the blade may not be touching the belt. In this case, the blade will push away and lose its shearing (cleaning) effect. The blade may also develop a flap at the tip which may trap material.

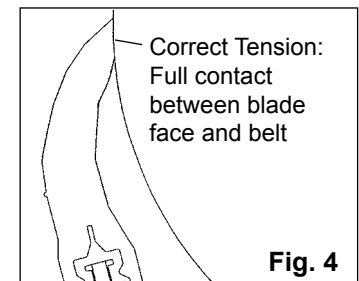
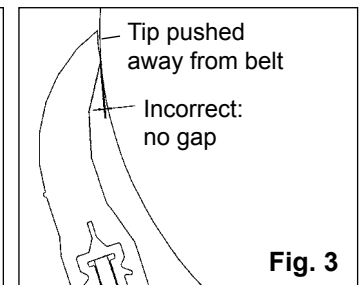
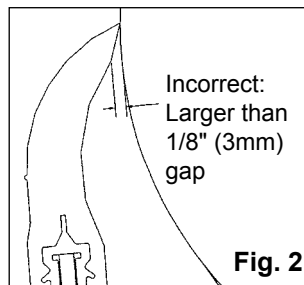
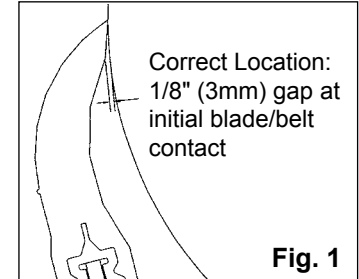

Correct Tensioning:

The blade should be tensioned until the gap is gone (Fig. 4).

The Material Path Option™

For optimal cleaning and reduced blade retensioning, the cleaner blade width should be sized to fit the material path of the belt. The material path is typically the center 2/3 of the belt width. Choosing a blade only slightly wider than the material path can decrease differential blade wear which reduces blade retensioning maintenance, as well as reducing the frequency of blade replacement.

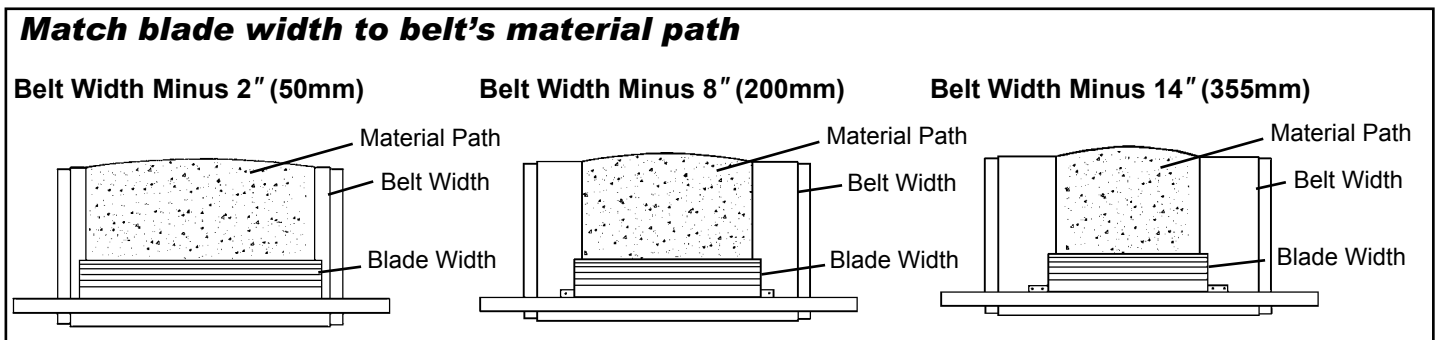

Section 4 - Installation Instructions - EZP-LS "Limited Space" Stainless Steel Precleaner with White ConShear Blade

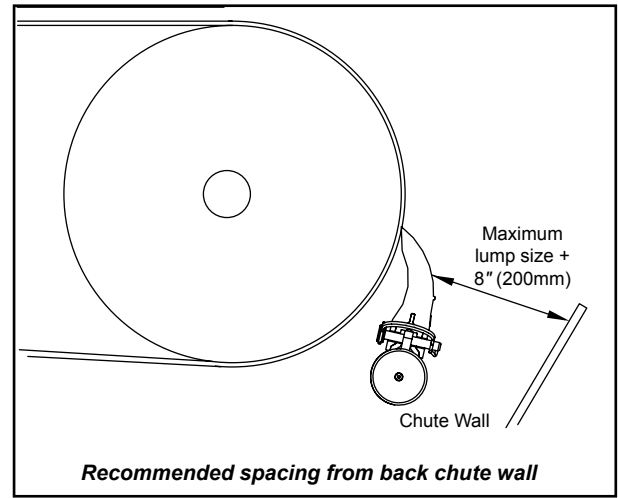
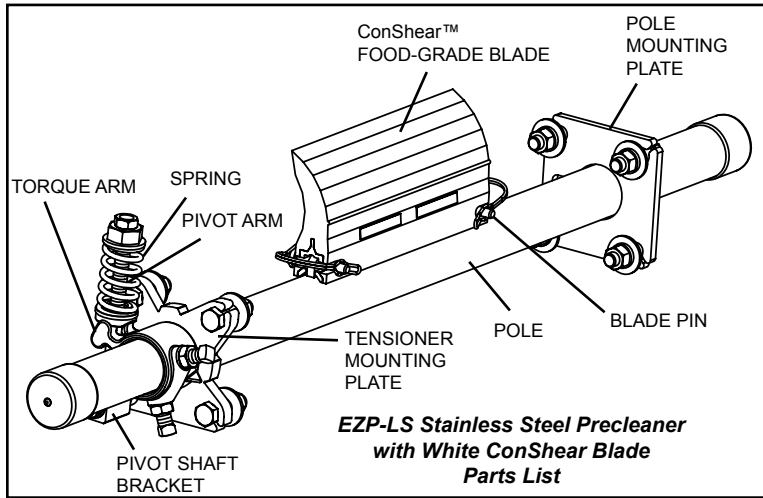

PHYSICALLY LOCK OUT AND TAG THE CONVEYOR AT THE POWER SOURCE BEFORE YOU BEGIN CLEANER INSTALLATION.

Installation specs and instructions are based on the assumption that the conveyor is in its working position (angle). If the conveyor angle will be different, the cleaner should be installed per the final position.

- Tools Needed:**
- Tape measure
 - Level
 - 3/4" (19mm) combination wrench
 - Ratchet with 3/4" (19mm) socket
 - Marking pen or soapstone
 - Adjustable pliers
 - Large adjustable wrench (to at least 1-1/8"/28mm)
 - Torch or welder

Pole Location Chart Imperial

A	X	Y	C
6"	2 5/8"	5 1/2"	6 1/8"
7"	3 1/4"	5 1/2"	6 3/8"
8"	3 7/8"	5 1/2"	6 3/4"
9"	4 3/8"	5 1/2"	7"
10"	5"	5 1/2"	7 3/8"
11"	5 1/2"	5 1/2"	7 3/4"
12"	6 1/8"	5 1/2"	8 1/4"
13"	6 5/8"	5 1/2"	8 5/8"
14"	7 1/8"	5 1/2"	9"
15"	7 5/8"	5 1/2"	9 3/8"
16"	8 1/4"	5 1/2"	9 7/8"
17"	8 3/4"	5 1/2"	10 3/8"
18"	9 1/4"	5 1/2"	10 3/4"
19"	9 3/4"	5 1/2"	11 1/4"
20"	10 1/4"	5 1/2"	11 5/8"
21"	10 3/4"	5 1/2"	12 1/8"
22"	11 1/4"	5 1/2"	12 1/2"

Pole Location Chart Metric

A	X	Y	C
150	65	140	150
175	81	140	155
200	96	140	162
225	109	140	171
250	125	140	179
275	138	140	189
300	153	140	198
325	166	140	209
350	178	140	219
375	191	140	229
400	206	140	239
425	219	140	252
450	231	140	263
475	244	140	273
500	256	140	284
525	269	140	295
550	281	140	307

1. Find the dimensions for the correct pole location.

Measure the pulley diameter (see Fig. 1). Find this pulley size (A) on the chart at right and determine the correct X, Y and C dimensions. Measure the X dimension horizontally from the center of the pulley shaft and make a mark. From that mark, draw a long vertical line down, then measure and mark Dim Y. This indicates the location of the center of the pole. Draw an extended horizontal line through this mark. Measure and mark the other side.
NOTE: Adjustments can be made to the X and Y coordinates to move away from obstacles as long as the C dimension remains constant. See Section 3.2. For open head installs, first add mounting support materials to the structure.

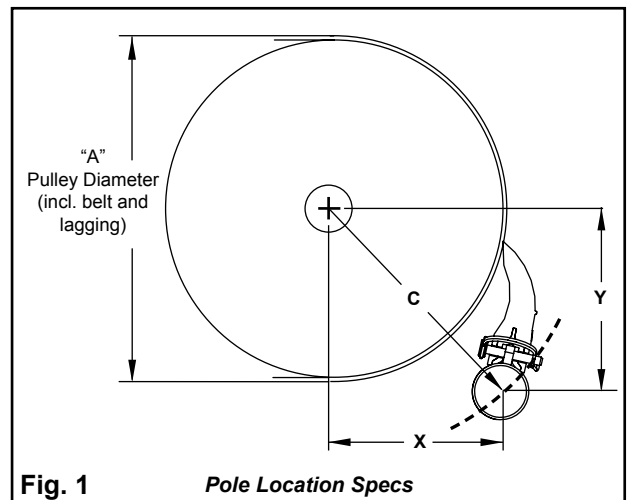

Section 4 – Installation Instructions (cont.)

- 2. Mark and cut the mounting plate holes.** Using the template provided in the instruction packet, position the pole access hole on the chute, aligning the hole notches with the layout lines. Position the keyway toward the pulley. Trace the pole cutout and mounting holes (Fig. 2). Cut the holes on both sides of the chute. NOTE: Hole cutouts are slotted for later adjustment if needed.

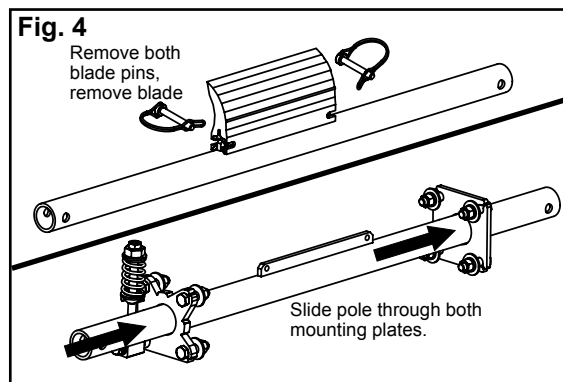
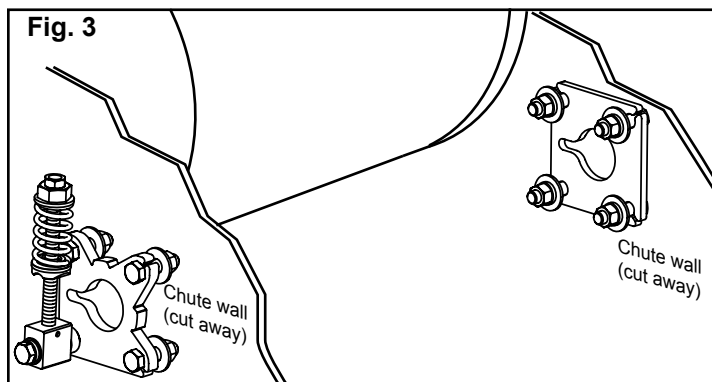
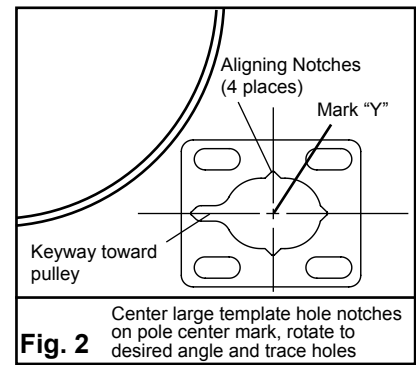

- 3. Install the mounting plates.** Bolt the tensioner mounting plate on the side with the tensioner and the pole mounting plate on the opposite side. Center the plates on the slotted holes and tighten the bolts (Fig. 3).

- 4. Install the pole.** Remove both blade pins and the blade from the pole, and insert the pole through both mounting plates (Fig. 4).

- 5. Center the cleaner on the belt.** Reinstall the blade with both blade pins. Center the blade on the belt (Fig. 5a). Rotate the blade up to the belt and check to insure that the blade is square to the pulley face. If it is not, loosen a mounting plate on one side and adjust the plate forward or backward to square the blade to the pulley, and retighten the bolts (Fig. 5b.)

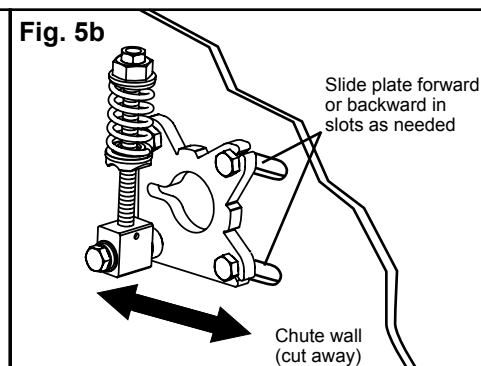
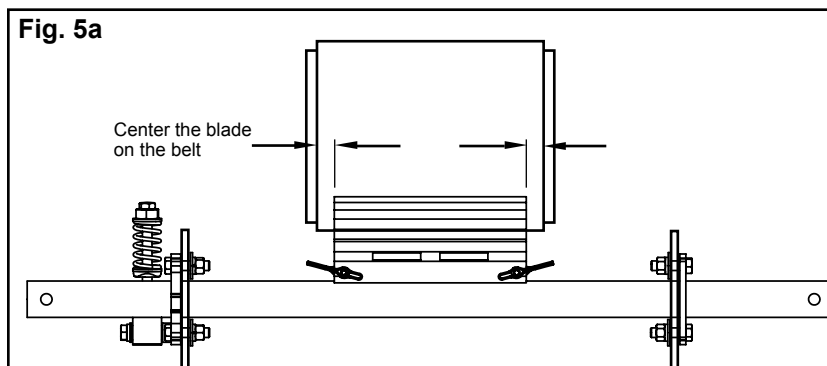

Section 4 – Installation Instructions (cont.)

6. **Install the tensioner.** Slide the torque arm onto the pole (Fig. 6a). **IMPORTANT:** To ensure the torque arm is installed correctly, note that the arm must fit snugly up to the mounting plate and the pointer **must** be to the inside. To correctly position the torque arm, rotate the pole until the blade contacts the belt. **Then align the torque arm pointer to notch “A” (Fig. 6b or 6c). There will be a 1" (25mm) gap between the pivot block and the torque arm nub if the tensioner is installed correctly.** While holding the blade firmly against the belt, tighten the set screws.

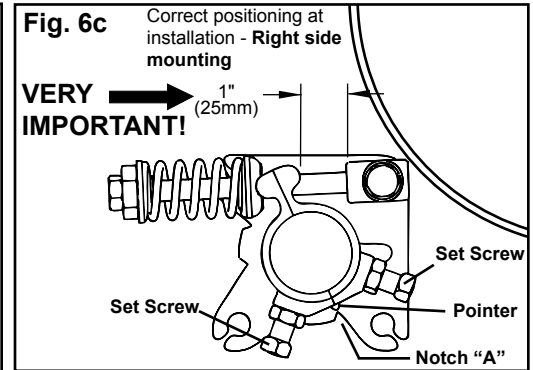
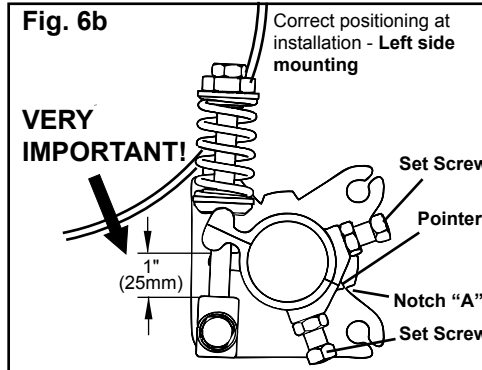
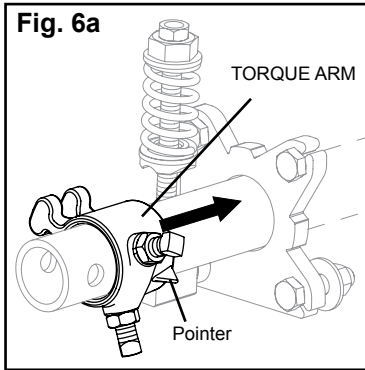

7. **Set the blade tension.** Make sure that the nubs on the torque arm are seated into the groove in the pivot washer (Fig. 7). Turn the tension nut so that enough pressure is applied to keep the pivot washer seated in the torque arm. Now, using a wrench, turn the tension nut until the spring is compressed to the length dimension specified in the spring length chart below. When the proper length is attained, lock in place with the tension jam nut.

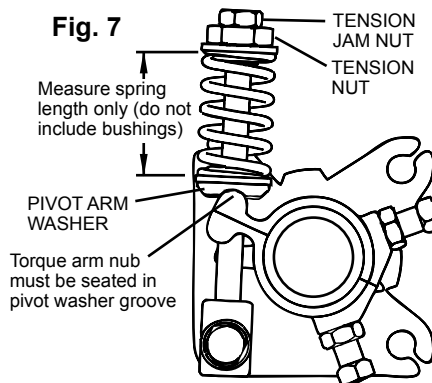

Spring Length Chart

Blade Width	1 Black Spring		1 White Spring		2 White Springs		
	in.	mm	in.	mm	in.	mm	
10	250	3 1/2	89	3 3/4	95	3 7/8	98
16	400	3 1/4	83	3 5/8	92	3 7/8	98
22	550	2 7/8	73	3 1/2	89	3 3/4	95
28	700	2 5/8	67	3 3/8	86	3 3/4	95
34	850	N/A	N/A	3 1/4	83	3 5/8	92
40	1000	N/A	N/A	3 1/8	79	3 5/8	92
46	1150	N/A	N/A	3	76	3 1/2	89
52	1300	N/A	N/A	N/A	N/A	3 1/2	89
58	1450	N/A	N/A	N/A	N/A	3 3/8	86

Shading indicates preferred spring option

8. **Confirm the correct pole location.** After the cleaner is installed, slide the Pole Location Gauge (provided in the instruction packet) between the pole and the pulley until it stops at a step (Fig. 8a). Read the flat area where the pole is resting. This diameter reading should be equal to the Dim. A (pulley diameter) used in Step 1. **NOTE:** If the diameter reading on the gauge is not the same as Dim. A in Step 1, check the “C” dimension and correct accordingly.

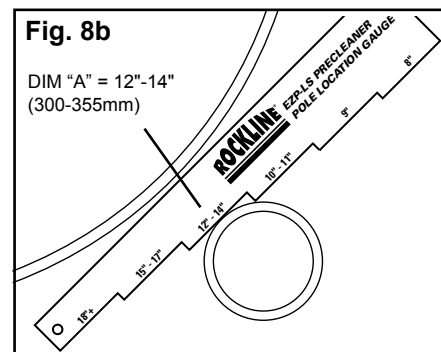
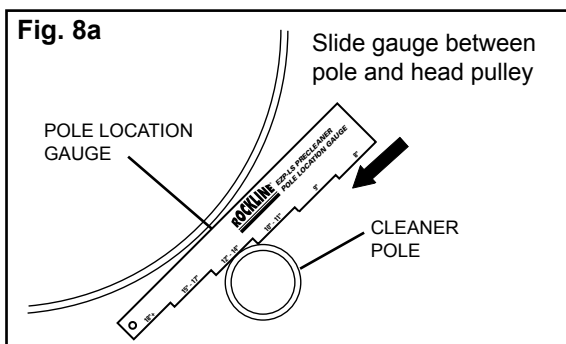

9. **Add pole caps.** Put a urethane cap on each pole end.
10. **Test run the conveyor and inspect the performance.** If vibration occurs or more cleaning efficiency is desired, make tensioning adjustments. (Also, check the Troubleshooting Guide.)

Section 5 - Pre-Operation Checklist and Testing

5.1 Pre-Op Checklist

- Recheck that all fasteners are tightened properly
- Add pole caps
- Apply all supplied labels to the cleaner
- Check the blade location on the belt
- Be sure that all installation materials and tools have been removed from the belt and the conveyor area

5.2 Test Run the Conveyor

- Run the conveyor for at least 15 minutes and inspect the cleaning performance
- Check the tensioner spring for recommended length (proper tensioning)
- Make adjustments as necessary

NOTE: Observing the cleaner when it is running and performing properly will help to detect problems or when adjustments are needed later.

Section 6 - Maintenance

Flexco belt cleaners are designed to operate with minimum maintenance. However, to maintain superior performance some service is required. When the cleaner is installed a regular maintenance program should be set up. This program will ensure that the cleaner operates at optimal efficiency and problems can be identified and fixed before the cleaner stops working.

All safety procedures for inspection of equipment (stationary or operating) must be observed. The EZP-LS Stainless Steel Precleaner with White ConShear Blade operates at the discharge end of the conveyor and is in direct contact with the moving belt. Only visual observations can be made while the belt is running. Service tasks can be done only with the conveyor stopped and by observing the correct lockout/tagout procedures.

6.1 New Installation Inspection

After the new cleaner has run for a few days a visual inspection should be made to ensure the cleaner is performing properly. Make adjustments as needed.

6.2 Routine Visual Inspection (every 2-4 weeks)

A visual inspection of the cleaner and belt can determine:

- If the spring length is the correct length for optimal tensioning
- If the belt looks clean or if there are areas that are dirty
- If the blade is worn out and needs to be replaced
- If there is damage to the blade or other cleaner components
- If fugitive material is built up on the cleaner or in the transfer area
- If there is cover damage to the belt
- If there is vibration or bouncing of the cleaner on the belt
- If a snub pulley is used, a check should be made for material buildup on the pulley

If any of the above conditions exist, a determination should be made on when the conveyor can be stopped for cleaner maintenance.

6.3 Routine Physical Inspection (every 6-8 weeks)

When the conveyor is not in operation and properly locked and tagged out a physical inspection of the cleaner to perform the following tasks:

- Clean material buildup off of the cleaner blade and pole.
- Closely inspect the blade for wear and any damage. Replace if needed.
- Check both blade pins for proper installation and condition. Replace if needed.
- Ensure full blade to belt contact.
- Inspect the cleaner pole for damage.
- Inspect all fasteners for tightness and wear. Tighten or replace as needed.
- Replace any worn or damaged components.
- Check the tension of the cleaner blade to the belt. Adjust the tension if necessary using the chart on the cleaner or the one on Page 9.
- When maintenance tasks are completed, test run the conveyor to ensure the cleaner is performing properly.



Section 6 - Maintenance (cont.)

6.4 Blade Replacement Inspection

The EZP-LS Stainless Steel Precleaner with White ConShear Blade has a built-in blade wear gauge to make it easy to determine when the blade is worn out and needs to be replaced. A pointer on the torque arm is set up when a new blade is installed to point at “Notch A” on the mounting plate (Fig. A). When the blade is worn out the pointer will point to “Notch B” (Fig. B).

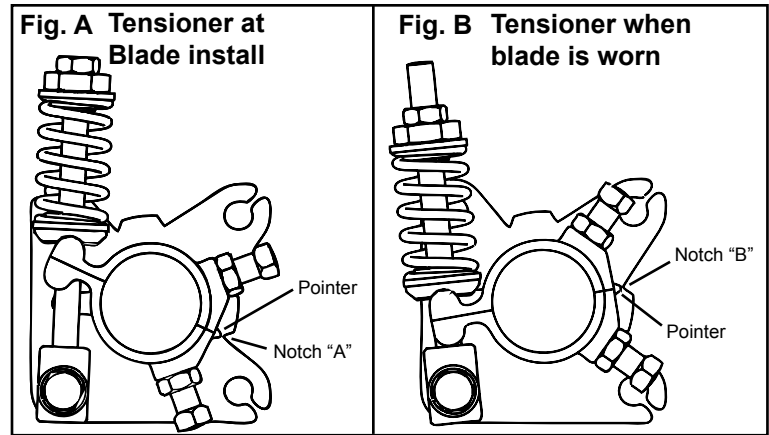

If the pointer is difficult to see, you can also check the blade wear by looking at the gap between the torque arm nub and the pivot block. At new blade install, the gap will be 1" (25mm) (Fig. C). When the blade is completely worn out and needs to be changed, there will be no gap (Fig. D).

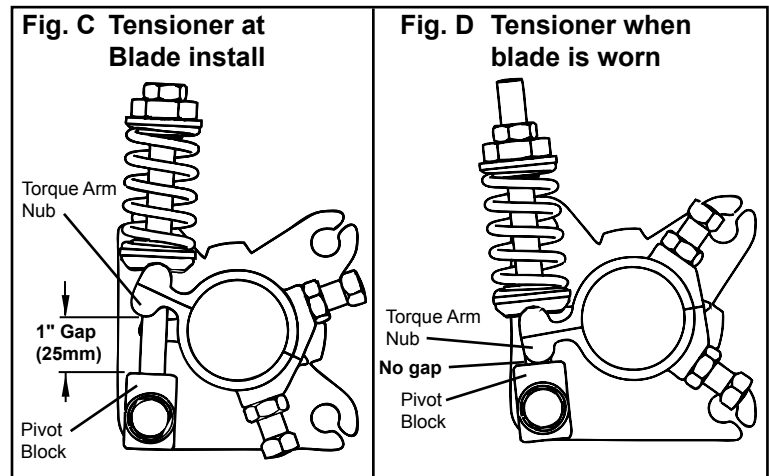

6.5 Blade Replacement Instructions

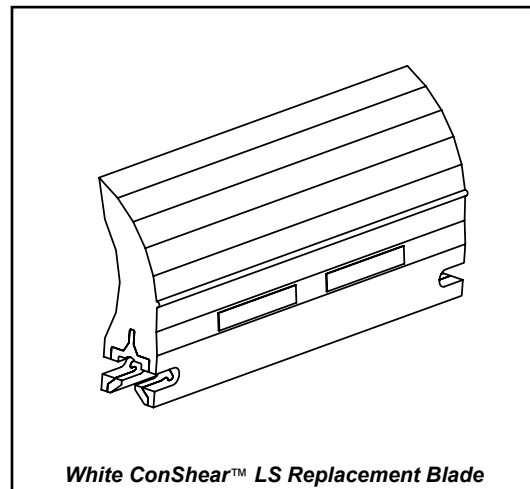
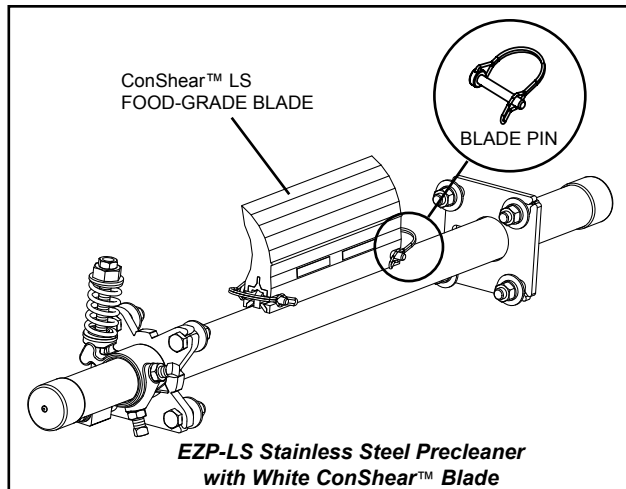

PHYSICALLY LOCK OUT AND TAG THE CONVEYOR AT THE POWER SOURCE BEFORE YOU BEGIN CLEANER MAINTENANCE.

Tools Needed:

- Tape measure
- (2) crescent wrenches (or 1-3/4" & 1-1/8"/45 & 28mm wrenches)
- Wire brush (for cleaning pole)
- Small putty knife (for cleaning pole)

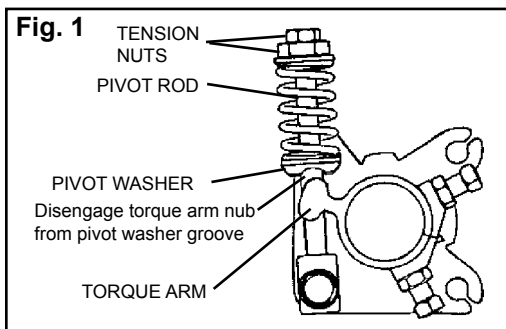

1. **Remove the tension.** Move both tension nuts to the end of the pivot rod (Fig. 1). Move the pivot rod and spring from the torque arm so the nub disengages from the pivot washer. The pole can now rotate down freely. This releases the tension of the blade on the belt.

2. **Remove the worn blade.** Remove one blade pin and remove the blade from the pole (Fig. 2). Clean all fugitive material from the pole.
NOTE: If blade is hard to remove use a screwdriver or hammer to loosen it and then remove.

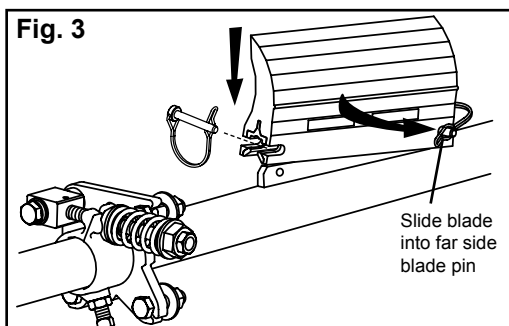
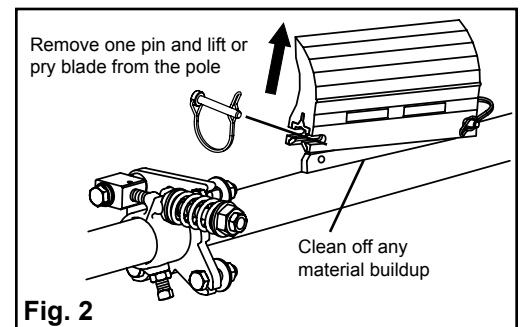

3. **Install the new blade.** Slide the new blade onto the pole, locking it into the far blade pin, then reinstall the removed blade pin (Fig. 3).
NOTE: Be sure the blade pin head is installed facing the belt.



Section 6 - Maintenance (cont.)

- 4. Reset the correct blade tension.** While holding the blade against the belt, make sure the pointer is pointing to Notch "A" and that there is a 1" (25mm) gap between the pivot block and the torque arm nub (Fig. 4a). Re-engage the pivot rod washer groove with the nub on the torque arm and turn the tension nuts until the correct spring length is achieved (Fig. 4b). Measure the length of the spring only (do not include the bushings).

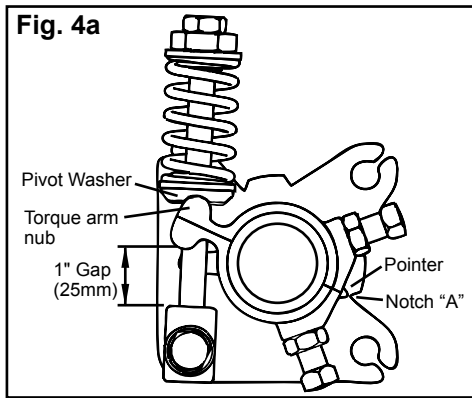

Spring Length Chart

Blade Width		Black Spring		White Spring		Dual White Spring	
in.	mm	in.	mm	in.	mm	in.	mm
10	250	3 1/2	89	3 3/4	95	3 7/8	98
16	400	3 1/4	83	3 5/8	92	3 7/8	98
22	550	2 7/8	73	3 1/2	89	3 3/4	95
28	700	2 5/8	67	3 3/8	86	3 3/4	95
34	850	N/A	N/A	3 1/4	83	3 5/8	92
40	1000	N/A	N/A	3 1/8	79	3 5/8	92
46	1150	N/A	N/A	3	76	3 1/2	89
52	1300	N/A	N/A	N/A	N/A	3 1/2	89
58	1450	N/A	N/A	N/A	N/A	3 3/8	86

Shading indicates preferred spring option

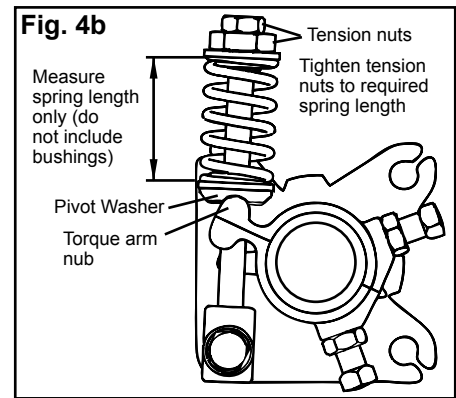

Test run the cleaner. Run the conveyor for at least 15 minutes and inspect the cleaning performance. Check the spring length for proper tensioning. Make adjustments as necessary.

Section 6 - Maintenance (cont.)

6.6 Maintenance Log

Conveyor Name/No. _____

Date: _____ Work done by: _____ Service Quote # _____

Activity: _____

Date: _____ Work done by: _____ Service Quote # _____

Activity: _____

Date: _____ Work done by: _____ Service Quote # _____

Activity: _____

Date: _____ Work done by: _____ Service Quote # _____

Activity: _____

Date: _____ Work done by: _____ Service Quote # _____

Activity: _____

Date: _____ Work done by: _____ Service Quote # _____

Activity: _____

Date: _____ Work done by: _____ Service Quote # _____

Activity: _____



Section 6 - Maintenance (cont.)

6.6 Cleaner Maintenance Checklist

Rockline Belt Cleaner: _____ Serial Number: _____

Blade Width: Belt minus 2" (50mm) Belt minus 8" (200mm) Belt minus 14" (355mm)

Beltline Information:

Beltline Number: _____ Belt Condition: _____

Belt Width: 12" 300mm 18" 450mm 24" 600mm 30" 750mm 36" 900mm 42" 1050mm 48" 1200mm 54" 1350mm 60" 1500mm

Head Pulley Diameter (Belt & Lagging): _____ Belt Speed: _____ fpm Belt Thickness: _____

Belt Splice _____ Condition of Splice _____ Number of splices _____ Skived Unskived

Material conveyed _____

Days per week run _____ Hours per day run _____

Blade Life:

Date blade installed: _____ Date blade inspected: _____ Estimated blade life: _____

Is blade making complete contact with belt? Yes No

Distance from wear line: LEFT _____ MIDDLE _____ RIGHT _____

Blade condition: Good Grooved Smiled Not contacting belt Damaged

Measurement of spring: Required _____ Currently _____

Was Cleaner Adjusted: Yes No

Pole Condition: Good Bent Worn

Lagging: Slide lag Ceramic Rubber Other None

Condition of lagging: Good Bad Other _____

Cleaner's Overall Performance: (Rate the following 1 - 5, 1=very poor - 5= very good)

Appearance: Comments: _____

Location: Comments: _____

Maintenance: Comments: _____

Performance: Comments: _____

Other Comments: _____

Section 7 - Troubleshooting

Problem	Possible Cause	Possible Solutions
Poor cleaning performance	Cleaner under-tensioned	Adjust to correct tension - see spring length chart
	Cleaner over-tensioned	Adjust to correct tension - see spring length chart
	Cleaner installed in wrong location	Verify "C" dimension, relocate to correct dimension
	Cleaner blade worn or damaged	Replace cleaner blade
Rapid Blade Wear	Tension on cleaner too high/low	Adjust to correct tension - see spring length chart
	Cleaner not located correctly	Check cleaner location for correct dimensions
	Blade attack angle incorrect	Check cleaner location for correct dimensions
	Material too abrasive for blade	Option: switch to alternate cleaner with metal blades
	Mechanical splice damaging blade	Repair, skive or replace splice
Center wear on blade (smile effect)	Blade wider than material path	Replace blade with width to match material path
	Tension on cleaner too high/low	Adjust to correct tension - see spring length chart
Unusual wear or damage to blade	Mechanical splice damaging blade	Repair, skive or replace splice
	Belt damaged or ripped	Repair or replace belt
	Cleaner not correctly located	Verify "C" dimension, relocate to correct dimension
	Damage to pulley or pulley lagging	Repair or replace pulley
Vibration or noise	Cleaner not located correctly	Verify "C" dimension, relocate to correct dimension
	Blade attack angle incorrect	Verify "C" dimension, relocate to correct dimension
	Cleaner running on empty belt	Use a spray pole when the belt is empty
	Cleaner tension too high/low	Adjust to correct tension or slight adjust to diminish
	Cleaner locking bolts not secure	Check and tighten all bolts and nuts
	Cleaner not square to head pulley	Verify "C" dimension, relocate to correct dimension
	Material buildup in chute	Clean up build-up on cleaner and in chute
Cleaner being pushed away from pulley	Cleaner tension not set correctly	Ensure correct tension/increase tension slightly
	Sticky material is overburdening cleaner	Increase tension; replace with cleaner with metal tips; replace with larger size cleaner
	Cleaner not set up correctly	Confirm location dimensions are equal on both sides

Section 8 - Specs and CAD Drawings

8.1 Specs and Guidelines

Pole Length Specifications

CLEANER SIZE		POLE LENGTH		MAXIMUM CONVEYOR SPAN	
in.	mm	in.	mm	in.	mm
12	300	42	1050	37	925
18	450	48	1200	43	1075
24	600	54	1350	49	1225
30	750	60	1500	55	1375
36	900	66	1650	61	1525
42	1050	72	1800	67	1675
48	1200	78	1950	73	1825
54	1350	88	2200	83	2075
60	1500	94	2350	89	2225

Pole Diameter - 1-7/8" (48 mm)

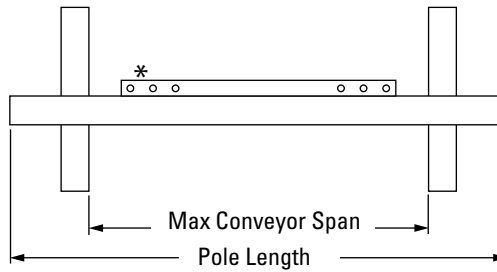

*Each pole size can be used with a blade size either belt width minus 2" (50mm), belt width minus 8" (200mm), or belt width minus 14" (350mm).

Pole Location Specs

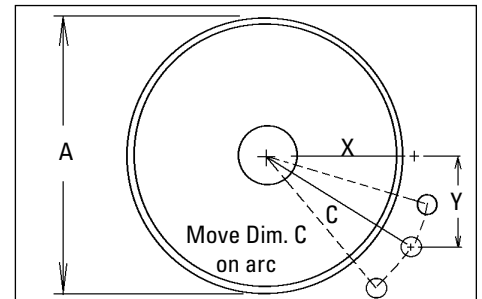

A = Pulley Diameter + Lagging and Belt
C = Critical Spec to move location if necessary

Clearance Guidelines for Installation

HORIZONTAL CLEARANCE REQUIRED		VERTICAL CLEARANCE REQUIRED	
in.	mm	in.	mm
3	75	6 1/2	165

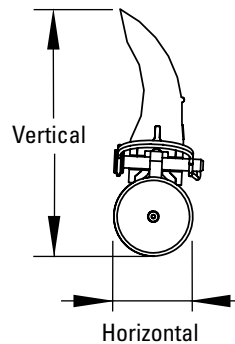

Pole Location Chart - Imperial

A	X	Y	C
6"	2 5/8"	5 1/2"	6 1/8"
7"	3 1/4"	5 1/2"	6 3/8"
8"	3 7/8"	5 1/2"	6 3/4"
9"	4 3/8"	5 1/2"	7"
10"	5"	5 1/2"	7 3/8"
11"	5 1/2"	5 1/2"	7 3/4"
12"	6 1/8"	5 1/2"	8 1/4"
13"	6 5/8"	5 1/2"	8 5/8"
14"	7 1/8"	5 1/2"	9"
15"	7 5/8"	5 1/2"	9 3/8"
16"	8 1/4"	5 1/2"	9 7/8"
17"	8 3/4"	5 1/2"	10 3/8"
18"	9 1/4"	5 1/2"	10 3/4"
19"	9 3/4"	5 1/2"	11 1/4"
20"	10 1/4"	5 1/2"	11 5/8"
21"	10 3/4"	5 1/2"	12 1/8"
22"	11 1/4"	5 1/2"	12 1/2"

Spring Length Chart

Stainless Steel EZP-LS w/White Blade

BLADE WIDTH		BLACK SPRING		WHITE SPRING		DUAL WHITE SPRINGS	
in.	mm	in.	mm	in.	mm	in.	mm
10	250	3 1/2	89	3 3/4	95	3 7/8	98
16	400	3 1/4	83	3 5/8	92	3 7/8	98
22	550	2 7/8	73	3 1/2	89	3 3/4	95
28	700	2 5/8	67	3 3/8	86	3 3/4	95
34	850	N/A	N/A	3 1/4	83	3 5/8	92
40	1000	N/A	N/A	3 1/8	79	3 5/8	92
46	1150	N/A	N/A	3	76	3 1/2	89
52	1300	N/A	N/A	N/A	N/A	3 1/2	89
58	1450	N/A	N/A	N/A	N/A	3 3/8	86

Shading indicates preferred spring option

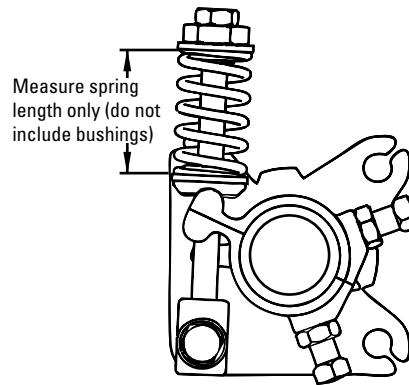

Pole Location Chart - Metric

A	X	Y	C
150	65	140	150
175	81	140	155
200	96	140	162
225	109	140	171
250	125	140	179
275	138	140	189
300	153	140	198
325	166	140	209
350	178	140	219
375	191	140	229
400	206	140	239
425	219	140	252
450	231	140	263
475	244	140	273
500	256	140	284
525	269	140	295
550	281	140	307

Specifications:

- Maximum Belt Speed 500 FPM (2.5M/sec)
- Temperature Rating (ConShear, ConShear White)..... -30°F to 180°F (-35°C to 82°C)
- Temperature Rating (ConShear High Temp)..... Up to 275°F (135°C) with spikes to 325°F (164°C)
- Minimum Pulley Diameter 6" (150mm)
- Blade Height 4.5" (115mm)
- Usable Blade Wear Length 2-3/8" (60mm)
- Blade Material (ConShear, ConShear High Temp) Urethane (proprietary blend for abrasion resistance and long wear)
- Blade Material (ConShear White)..... Food Grade (white) FDA Approved
- Available for Belt Widths..... 12" to 60" (300 to 1500mm).

8.2 CAD Drawing - EZP-LS SS, Belt Width Minus 2" (50mm)

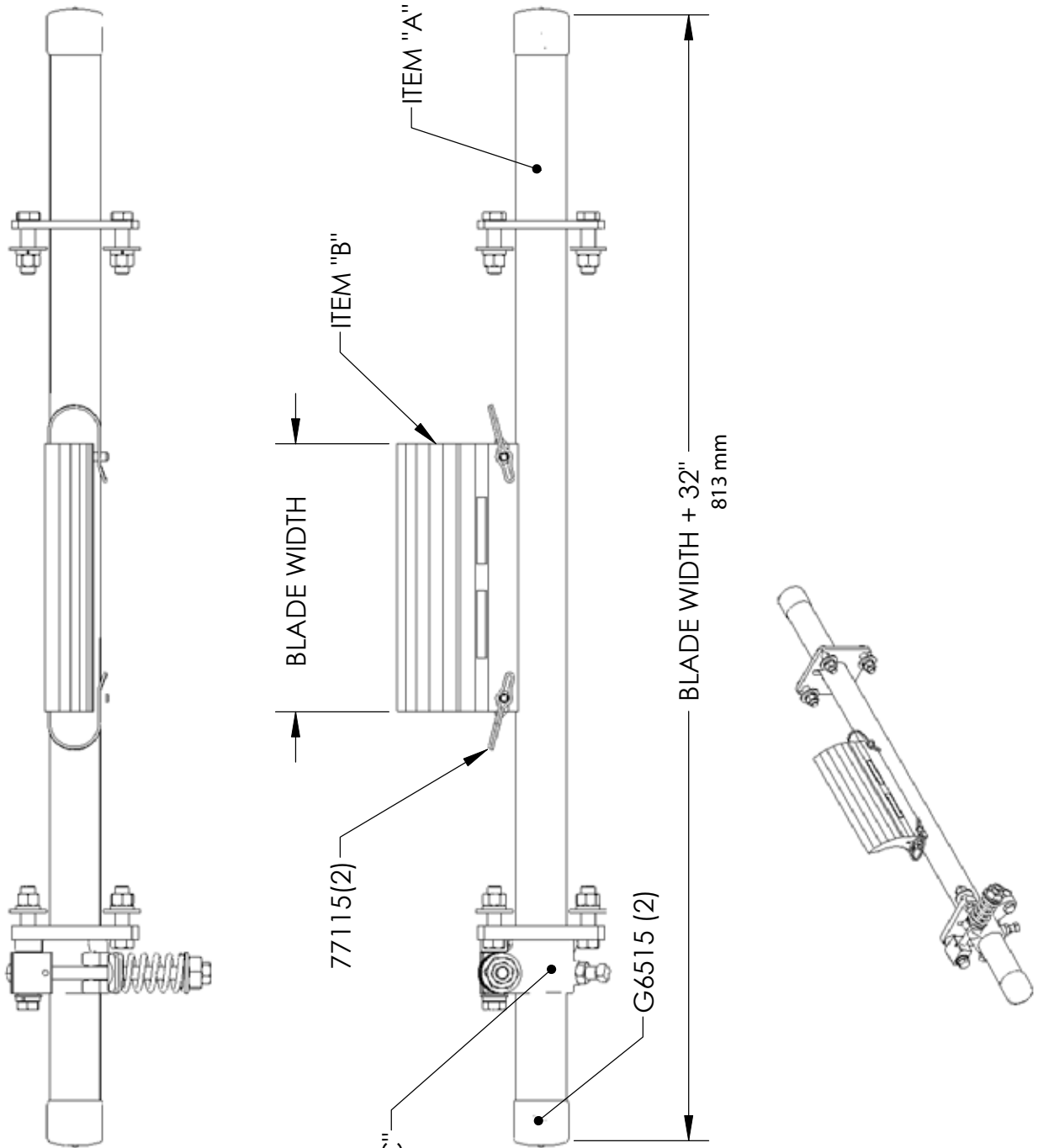

ASSY. NUMBER	BLADE WIDTH	ITEM "A"	ITEM "B"	ITEM "C"
77144	10"(250mm)	77079	77097	77124
77145	16"(400mm)	77080	77098	77124
77146	22"(550mm)	77081	77099	77124
77147	28"(700mm)	77082	77100	77124
77148	34"(850mm)	77083	77101	77125
77149	40"(1000mm)	77084	77102	77125
77150	46"(1150mm)	77085	77103	77125
77151	52"(1300mm)	77086	77104	77126
77152	58"(1450mm)	77087	77105	77126

Section 8 - Specs and CAD Drawings (cont.)

8.2 CAD Drawing - EZP-LS SS, Belt Width Minus 8" (200mm)

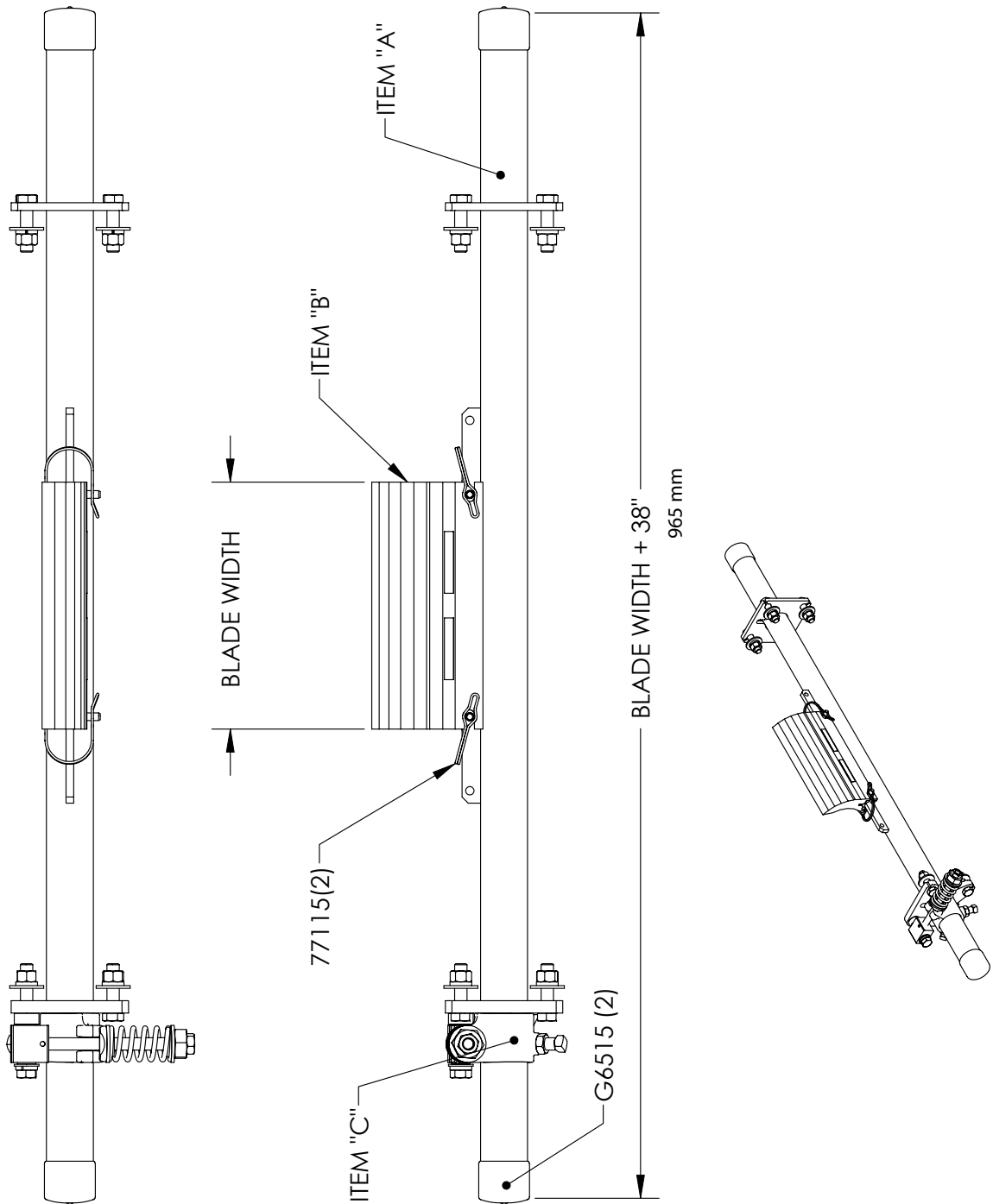

ASSY. NUMBER	BLADE WIDTH	ITEM "A"	ITEM "B"	ITEM "C"
77153	10"(250mm)	77080	77097	77124
77154	16"(400mm)	77081	77098	77124
77155	22"(550mm)	77082	77099	77124
77156	28"(700mm)	77083	77100	77124
77157	34"(850mm)	77084	77101	77125
77158	40"(1000mm)	77085	77102	77125
77159	46"(1150mm)	77086	77103	77125
77160	52"(1300mm)	77087	77104	77126

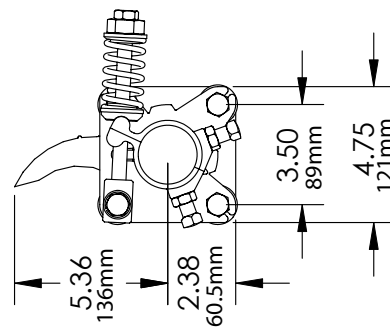

Section 9 - Replacement Parts

9.1 Replacement Parts List

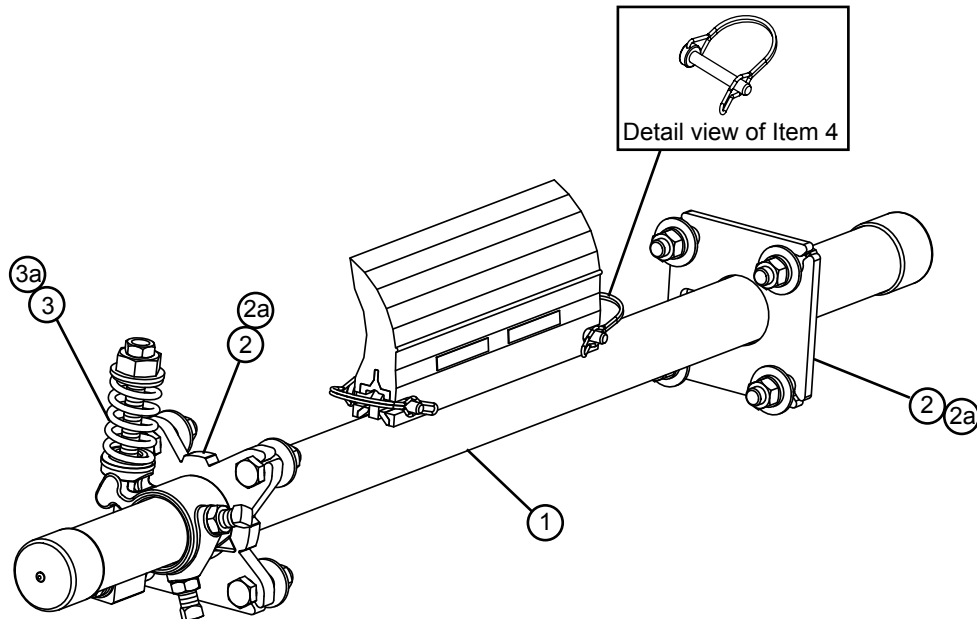

Replacement Parts

REF	DESCRIPTION	ORDERING NUMBER	ITEM CODE	WT. LBS.	PRICE
1	12" (300mm) SS Pole	LSP12-S/S	77079	13.3	\$ 418.31
	18" (450mm) SS Pole	LSP18-S/S	77080	15.5	497.49
	24" (600mm) SS Pole	LSP24-S/S	77081	17.7	577.52
	30" (750mm) SS Pole	LSP30-S/S	77082	19.9	603.99
	36" (900mm) SS Pole	LSP36-S/S	77083	22.1	726.46
	42" (1050mm) SS Pole	LSP42-S/S	77084	24.3	738.11
	48" (1200mm) SS Pole	LSP48-S/S	77085	26.5	780.80
	54" (1350mm) SS Pole	LSP54-S/S	77086	28.7	806.76
60" (1500mm) SS Pole	LSP60-S/S	77087	31.0	857.56	
2	SS Mounting Plate Kit (10"-46"/250-1150mm)* (incl. 1 tensioner mounting plate and 1 pole mounting plate)	LSTMPK-S/S	78933	3.6	152.07
2a	SS Mounting Plate Kit (52"+/1300mm+)* (incl. 2 tensioner mounting plates)	LSTMPK2-S/S	78862	7.2	192.39
3	Tension Spring - Black (1 ea.) for blades 10"-28" (250-700mm)	LS-SB-S/S	78387	.2	73.33
3a	Tension Spring - White (1 ea.) for blades 34" - 70" (850 - 1750mm)	LS-SW-S/S	78850	.3	39.33
4	SS LS Blade Pin (1 ea.)	LS-BP-S/S	77115	.1	7.26
-	SS LST Spring Tensioner* - Black incl. 1 ea. items 2 & 3 for blades 10"-28" (250 - 700mm)	LST-B-S/S	77124	7.5	511.68
-	SS LST Spring Tensioner* - White incl. 1 ea. items 2 & 3a for blades 34"- 46" (850 - 1150mm)	LST-W-S/S	77125	7.6	460.92
-	SS LST Spring Tensioner* - White (dual) incl. 1 ea. item 2a and 2 ea. item 3a for blades 52" - 70" (1300 - 1750mm)	LST-W-S/S-2	77126	15.2	795.14

*Hardware Included

Spring Tensioner Selection Chart

CLEANER BLADE WIDTH	77124 Black (single)	77125 White (single)	77126 White (dual)
Food Grade-LS 10" - 28" (250 - 700mm)	X		
Food Grade-LS 34" - 46" (850 - 1150mm)		X	
Food Grade-LS 52" - 70" (1300 - 1750mm)			X

For best results use Flexco Genuine Replacement Blades and Parts.



Section 9 - Replacement Parts (cont.)

9.2 ConShear™ LS Replacement Blades



Blade Width Selection

BELT WIDTH		BELT WIDTH MINUS 2" (50mm)		BELT WIDTH MINUS 8" (200mm)		BELT WIDTH MINUS 14" (350mm)	
in.	mm	in.	mm	in.	mm	in.	mm
12	300	10	250	N/A	N/A	N/A	N/A
18	450	16	400	10	250	N/A	N/A
24	600	22	550	16	400	10	250
30	750	28	700	22	550	16	400
36	900	34	850	28	700	22	550
42	1050	40	1000	34	850	28	700
48	1200	46	1150	40	1000	34	850
54	1350	52	1300	46	1150	40	1000
60	1500	58	1450	52	1300	46	1150

Replacement ConShear™-LS Blades

BLADE WIDTH		ORDERING NUMBER	ITEM CODE	WT. LBS.
in.	mm			
10	250	CRB-LS10	77088	2.1
16	400	CRB-LS16	77089	3.3
22	550	CRB-LS22	77090	4.6
28	700	CRB-LS28	77091	5.8
34	850	CRB-LS34	77092	7.1
40	1000	CRB-LS40	77093	8.3
46	1150	CRB-LS46	77094	9.6
52	1300	CRB-LS52	77095	10.8
58	1450	CRB-LS58	77096	12.1

Other blade sizes available upon request.
Lead time: 1 working day

Replacement ConShear™-LS High-Temp Blades

BLADE WIDTH		ORDERING NUMBER	ITEM CODE	WT. LBS.
in.	mm			
10	250	CRB-LS10HT	77551	2.1
16	400	CRB-LS16HT	77552	3.3
22	550	CRB-LS22HT	77553	4.6
28	700	CRB-LS28HT	77554	5.8
34	850	CRB-LS34HT	77555	7.1
40	1000	CRB-LS40HT	77556	8.3
46	1150	CRB-LS46HT	77557	9.6
52	1300	CRB-LS52HT	77558	10.8
58	1450	CRB-LS58HT	77559	12.1

Other blade sizes available upon request.
Lead time: 1 working day

Replacement ConShear™-LS White Blades (Chemical Resistant/Food Grade) ‡

BLADE WIDTH		ORDERING NUMBER	ITEM CODE	WT. LBS.
in.	mm			
10	250	CRB-LS10W	77097	2.1
16	400	CRB-LS16W	77098	3.3
22	550	CRB-LS22W	77099	4.6
28	700	CRB-LS28W	77100	5.8
34	850	CRB-LS34W	77101	7.1
40	1000	CRB-LS40W	77102	8.3
46	1150	CRB-LS46W	77103	9.6
52	1300	CRB-LS52W	77104	10.8
58	1450	CRB-LS58W	77105	12.1

Other blade sizes available upon request.
Lead time: 1 working day

‡ All ingredients used in the urethane formulation of this blade comply with the relevant requirements of 21 CFR (FDA Code of Federal Regulations) for use in repeated bulk dry food applications

Product Notes:

- Take blade width and ordering number from the worn blade and use the Replacement Blade Chart.
- For optimal cleaning and reduced blade retensioning maintenance, the cleaner blade width should be sized to fit the material path of the belt. The material path is typically 2/3 of the belt width.
- The ConShear™ blade has a faceted profile that renews the cleaning edge as it wears.
- Visual tension check. No guesswork on blade tensioning. Simply measure the spring, check label on tensioner and turn adjusting nut to restore optimal tension.
- ConShear blades are made of a special long-wearing urethane.
- A molded-in blade wear line indicates when the blade is worn out and needs to be replaced.
- Blade replacement is quick. Pull one pin, remove the old blade and slide the new one in.

U.S. Patent No. D482,508S (blade)

Patent Pending (tensioner)

Section 10 - Other Flexco Conveyor Products

Flexco provides many conveyor products that help your conveyors to run more efficiently and safely. These components solve typical conveyor problems and improve productivity. Here is a quick overview on just a few of them:

EZP1 Precleaner



- Patented ConShear™ blade renews its cleaning edge as it wears
- Visual Tension Check™ for optimal blade tensioning and simple retensioning
- Quick and easy one-pin blade replacement
- Material Path Option™ for optimal cleaning and reduced maintenance

DRX Impact Beds



- Exclusive Velocity Reduction Technology™ to better protect the belt
- Slide-Out Service™ gives direct access to all impact bars for change-out
- Impact bar supports for longer bar life
- 4 models to custom fit to the application

EZS2 Secondary Cleaner

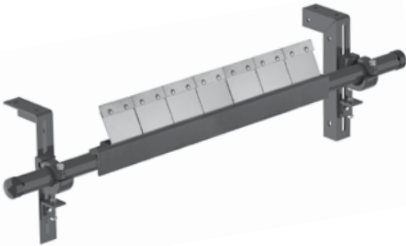

- Long-wearing tungsten carbide blades for superior cleaning efficiency
- Patented FormFlex™ cushions independently tension each blade to the belt for consistent, constant cleaning power
- Easy to install, simple to service
- Works with Flexco mechanical belt splices

PT Max™ Belt Trainer

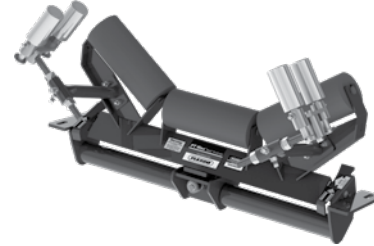

- Patented “pivot & tilt” design for superior training action
- Dual sensor rollers on each side to minimize belt damage
- Pivot point guaranteed not to freeze up
- Available for topside and return side belts

Flexco Specialty Belt Cleaners



- “Limited space” cleaners for tight conveyor applications
- High Temp cleaners for severe, high heat applications
- A rubber fingered cleaner for chevron and raised rib belts
- Multiple cleaner styles in stainless steel for corrosive applications

Belt Plows



- A belt cleaner for the tail pulley
- Exclusive blade design quickly spirals debris off the belt
- Economical and easy to service
- Available in vee or diagonal models







2525 Wisconsin Avenue • Downers Grove, IL 60515-4200 • USA
Tel: (800) 541-8028 • Fax: (630) 971-1180 • E-mail: info@flexco.com

Visit www.flexco.com for other Flexco locations and products.

©2021 Flexible Steel Lacing Company. 08/10/21. For reorder: X2666

