

# Replacement Anvil

## Alligator® Ready Set Gold Class™ Plus

### Instructions

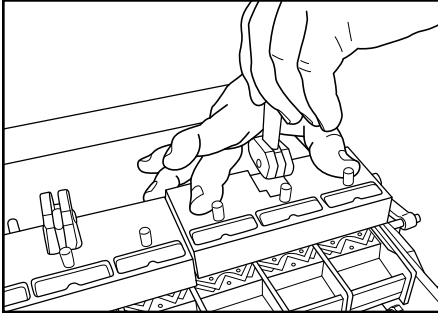

1. Release cam lever, press down block and turn cam lever counterclockwise.

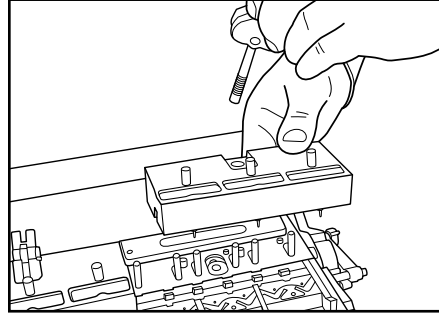

2. Lift cam lever and remove cam lever and guide block over the damaged anvil.

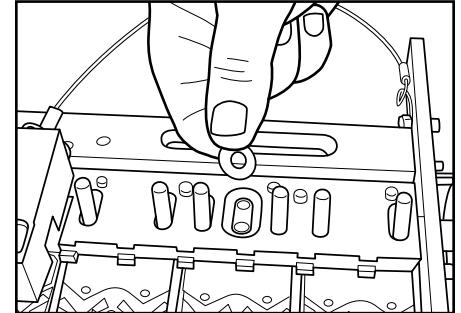

3. Remove washer from the tool. Set aside.

**4. For tools with anti-lifting mechanism only:** There are (2) anti-lifting mechanisms per tool, only the left-hand mechanism is shown in Step 5.

Remove screws that reside below each spring of the anti-lifting mechanism for a total of (4) screws (2 screws left-hand mechanism, 2 screws right-hand mechanism). Next, remove each spring (total of 4) and push the anvil plate assembly inward, then proceed in removing the anti-lifting mechanism from the tool.

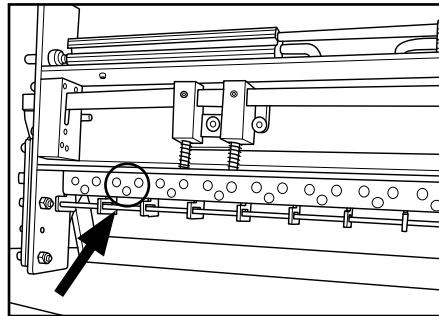

5. Turn tool on its side and identify the three screws that secure the anvil to be replaced.

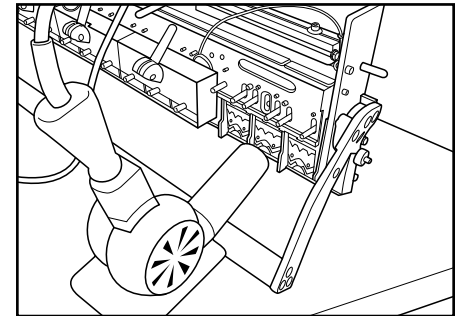

6. Put on heat resistant gloves. Use a 1500W heat gun on high and heat the anvil for approximately 10 minutes. (Caution - Please read all manufacturer instructions on proper use of the heat gun). This will loosen the Loctite. Allow time for plate and screws to cool.

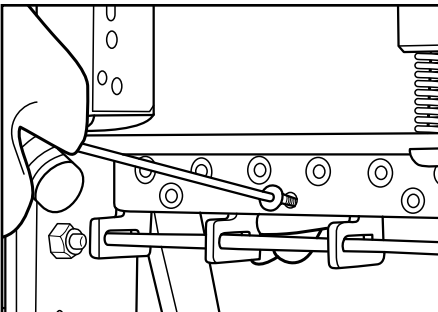

7. Using enclosed Allen wrench, turn three screws counterclockwise.

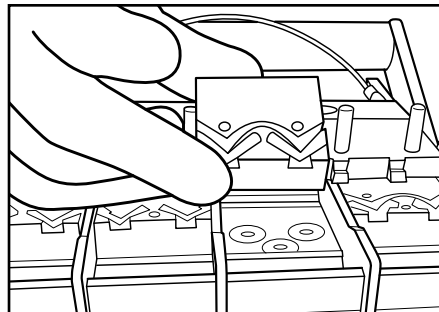

8. Remove damaged anvil from the tool.

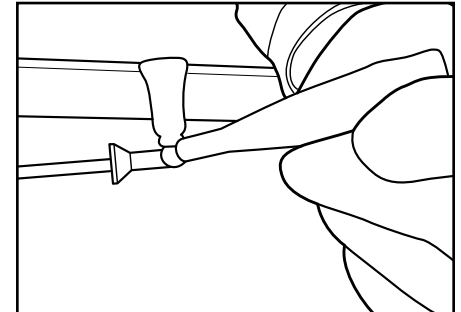

9. Open enclosed Loctite tube and apply Loctite to the three anvil screws included in this package.

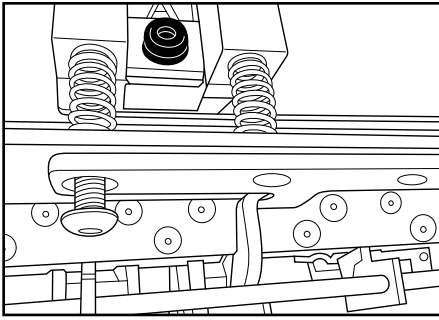

**10. For tools with anti-lifting mechanism only:** Replace the anti-lifting mechanisms from the top of the tool. Next, apply Loctite to the end of each screw (total of 4) and slowly thread until they have engaged in the tool. Replace the (4) springs and continue to tighten the screws (screws go through the center of each spring) until fully seated.

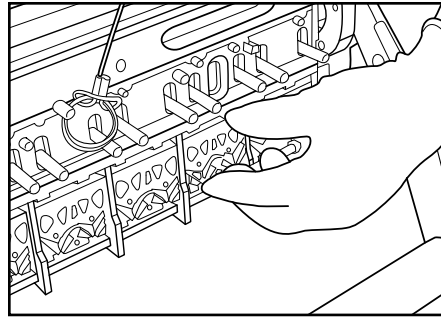

**11. Hold anvil plate, line up screws, and tighten all three screws.**

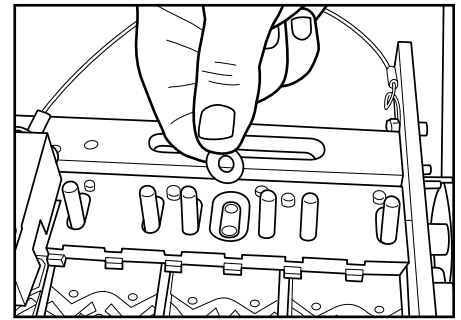

**12. Replace washer that was removed in Step 3.**

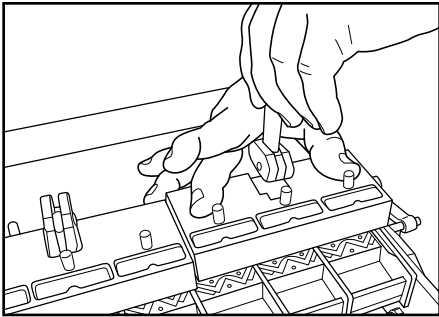

**13. Replace guide block and cam lever. Tighten cam lever. Do not use tool for 24 hours to allow Loctite to dry.**



2525 Wisconsin Avenue • Downers Grove, IL 60515-4200 USA  
Tel: 1-630-971-0150 • Fax: 1-630-971-1180 • E-mail: info@flexco.com

Visit [www.flexco.com](http://www.flexco.com) for other Flexco locations and products.

©2011 Flexible Steel Lacing Company. 12-13. For Reorder: X2633

