

MHCP Heavy-Duty Cartridge Precleaner

Massive, Rugged, Ready to Work

The MHCP Heavy-Duty Cartridge Precleaner features segmented SuperShear™ blades that are engineered to stand up to the most abusive beltline conditions, such as wet, sticky fire clay, and maintain constant cleaning force. The massive blades have an extended wear life and also a quick-change blade cartridge feature. This is an extreme-duty cleaner that gets the job done – and with minimal maintenance.

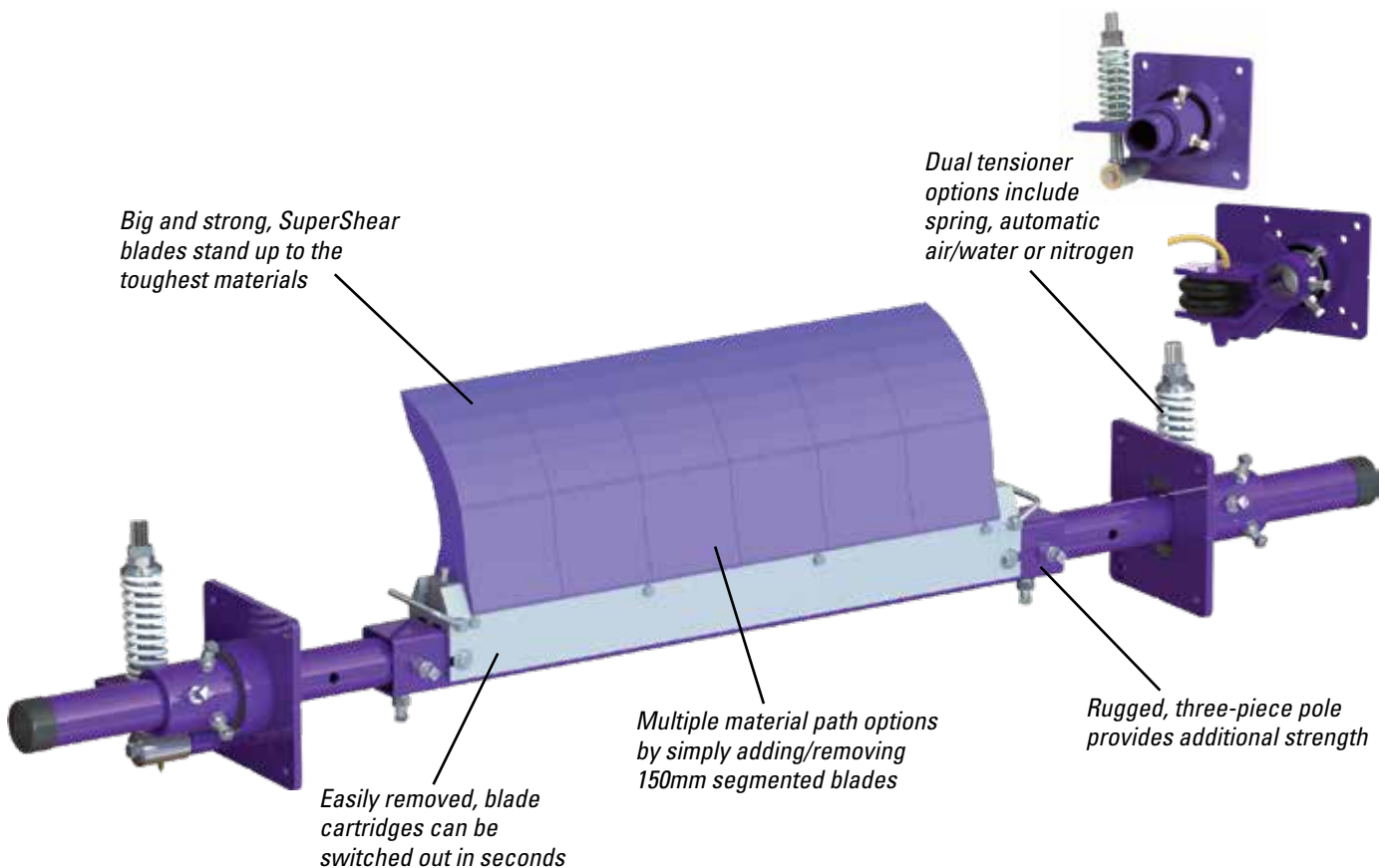

Features and Benefits

- **Works with mechanical fasteners.** The shock-absorbing tensioners allow mechanical splices, skived or unskived, to pass without damage to the splice or the cleaner and with minimal cleaning disruption.
- **Retrofits to other cleaners.** The MHCP blade cartridge will fit on the poles of other cleaner manufacturers. Now you can experience the benefits of the SuperShear blades without having to install a completely new cleaner.
- **Complete cleaning system.** When teamed with the MHS HD Secondary Cleaner, it makes up a system that delivers maximum cleaning power for the most abusive conveyor applications.
- **Made for mining conveyors.** Made from heavy-duty, corrosion-resistant steel, the MHCP is available in sizes for belt widths from 600 to 3000mm (24" to 120"). Additional sizes are available upon request.

MHCP Heavy-Duty Cartridge Precleaner

Maximum Belt Speed

6 m/s (1200 FPM)

Temperature Rating

-35° C to 82° C (-30° F to 180° F)

Minimum Pulley Diameter

500 mm (20")

Blade Height

350 mm (14")

CEMA Cleaner Rating

Class 5

Usable Blade Wear Length

200 mm (8")

Blade Material

Urethane 90 durometer (proprietary blend for abrasion resistance and long wear)

Available for Belt Widths

600 to 3000 mm (24" to 120")

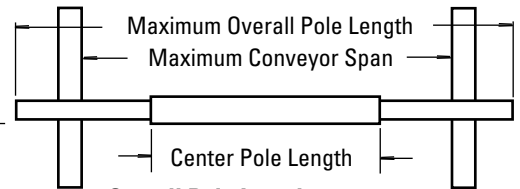

Overall Pole Length

Cleaner size + 1450 mm (58")

Maximum Conveyor Span

Cleaner size + 1050 mm (42")

Ordering Information

MHCP HD Cartridge Primary Cleaner with Spring Tensioner (PST)					
Belt Width		Blade Coverage		Ordering Number	Item Code
mm	in.	mm	in.		
600	24	450	18	MHCP-24S	75929
750	30	600	24	MHCP-30S	75930
900	36	750	30	MHCP-36S	75931
1050	42	900	36	MHCP-42S	75932
1200	48	1050	42	MHCP-48S	75933
1350	54	1200	48	MHCP-54S	75934
1500	60	1350	54	MHCP-60S	75935
1800	72	1650	66	MHCP-72S	75936
2100	84	1950	78	MHCP-84S	76800
2400	96	2250	90	MHCP-96S	78955
2700	108	2550	102	MHCP-108S	90167
3000	120	2850	114	MHCP-120S	90168

Lead time: 1 working day

MHCP HD Cartridge Precleaner with Portable Air Tensioner (PAT)					
Belt Width		Blade Coverage		Ordering Number	Item Code
mm	in.	mm	in.		
600	24	450	18	MHCP-24P	78723
750	30	600	24	MHCP-30P	78724
900	36	750	30	MHCP-36P	78725
1050	42	900	36	MHCP-42P	78726
1200	48	1050	42	MHCP-48P	78727
1350	54	1200	48	MHCP-54P	78728
1500	60	1350	54	MHCP-60P	78729
1800	72	1650	66	MHCP-72P	78730
2100	84	1950	78	MHCP-84P	78731
2400	96	2250	90	MHCP-96P	78959
2700	108	2550	102	MHCP-108P	90169
3000	120	2850	114	MHCP-120P	90170

Lead time: 1 working day

Blade Cartridge Kits (Includes blades, cartridge, and mounting bolts)			
Belt Width		Ordering Number	Item Code
mm	in.		
600	24	MHCP-BCK24	75953
750	30	MHCP-BCK30	75954
900	36	MHCP-BCK36	75955
1050	42	MHCP-BCK42	75956
1200	48	MHCP-BCK48	75957
1350	54	MHCP-BCK54	75958
1500	60	MHCP-BCK60	75959
1800	72	MHCP-BCK72	75960
2100	84	MHCP-BCK84	76810
2400	96	MHCP-BCK96	78957
2700	108	MHCP-BCK108	90415
3000	120	MHCP-BCK120	90416

NOTE: For easy blade changeout, remove cartridge with worn blades and replace with new blade cartridge kit. New blades can then be installed in the old cartridge for the next changeout.

Lead time: 1 working day

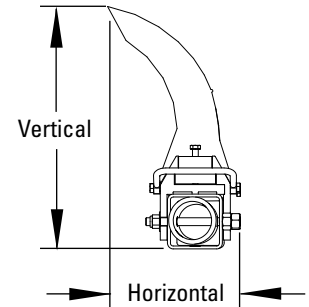

Horizontal Clearance Required
175 mm (7")

Vertical Clearance Required
475 mm (19")

Pole Location Chart				
A	X	Y	C	
500	254	365	445	
525	267	365	451	
550	279	365	460	
575	292	365	467	
600	305	365	476	
625	318	365	483	
650	330	365	492	
675	343	365	502	
700	356	365	511	
725	368	365	518	
750	381	365	527	
775	394	365	537	
800	406	365	546	
825	419	365	556	
850	432	365	565	
875	445	365	575	
900	457	365	584	
925	470	365	594	
950	483	365	606	
975	495	365	616	
1000	508	365	625	
1025	521	365	635	
1050	533	365	648	
1075	546	365	657	
1100	565	365	673	
1125	581	365	686	
1150	597	365	699	
1175	610	365	711	
1200	625	365	724	

Pole Location Specs

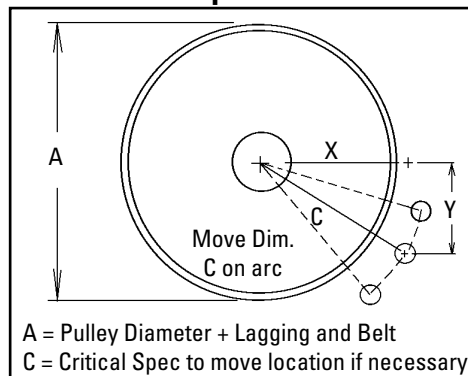

Authorized Distributor:



240 Macpherson Road • #02-01 • Singapore 348574
Tel: +65-6484-1533 • Fax: +65-6484-1531 • E-mail: asiasales@flexco.com

Visit www.flexco.com for other Flexco locations and products.

©2022 Flexible Steel Lacing Company. 10/03/22. For reorder: X2624

