

Installation Instructions

MHS or MDWS Secondary with SAT XD Tensioners

Physically lock out and tag the conveyor at the power source before you begin cleaner installation.

- 1. Install the air/water tensioner mounting bases.** Clamp the mounting base into position so the flange is even with the belt (Fig. 1). Bolt the mounting base in place. Locate and install the mounting base on the opposite side.
- 2. Install the pole.** Slide the pole into one torsion pole mount as far as needed and locate the other end into the opposite mount. If there is not enough space, remove one of the mounting bases, slide the pole through the torsion pole mount, and remount the base.
- 3. Set the blade angle.** Center the pole/blades on the belt.

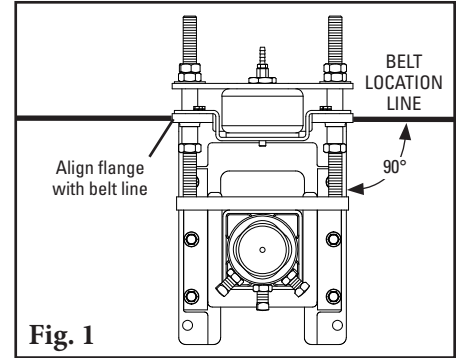

MHS: Rotate the pole until the tips are perpendicular to the belt, using the black “MHS Reversing/SAT XD” side of the tip setup gauge provided (Fig. 2a).

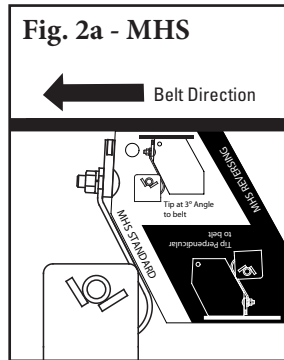

MDWS: Rotate pole until blade is perpendicular to the belt, using the blade setup gauge provided (Fig. 2b).

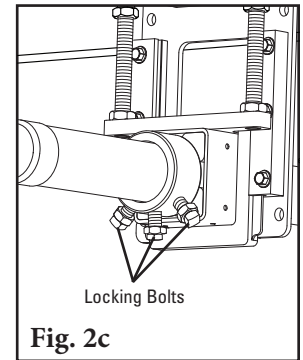
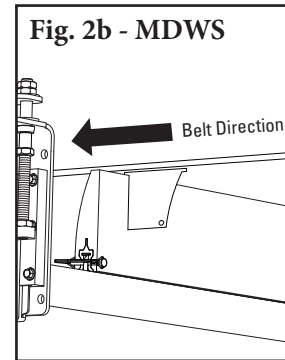

Tighten the three locking bolts on each torsion pole mount to lock the pole in place. Best practice is to first tighten the middle bolt before tightening the outer bolts to ensure everything is secure (Fig. 2c). There should be no blade-to-belt contact while locking the pole in the correct position. If contact occurs, double check the dimension from Step 1.

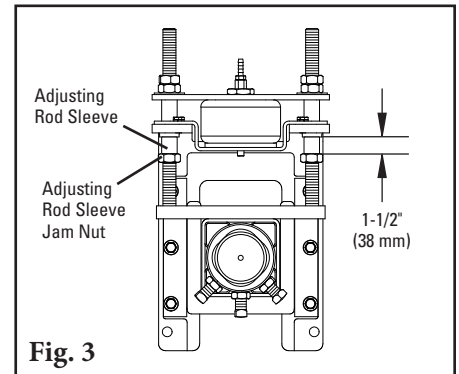

- 4. Set adjusting rod sleeve.** After setting the blade tension, screw the adjusting rod sleeve into the UHMW bushing until 1-1/2" (38 mm) is showing (Fig. 3). Tighten the adjusting rod sleeve jam nut.
- 5. Connect the supply lines and set tension pressure.** With the parts supplied, attach a line to each air bag and run the lines to the outlet side of the control box (Fig. 4).

NOTE: Be sure lines are safely away from the belt. Connect the line from the inlet side of the box to the site's supply or air tank. Test the connections for leaks and set the pressure per the chart below. Pressure may be reduced to suit application.

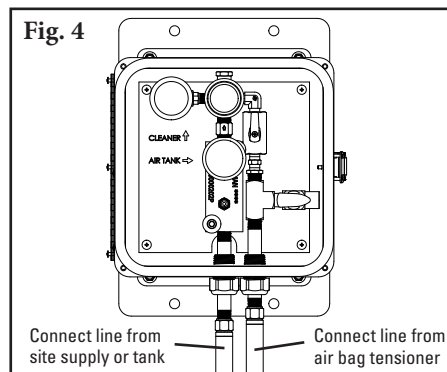

- 6. Test run the cleaner and inspect the cleaning performance.** If vibration occurs, increase tip layback by a small amount (approx. 3 degrees).

SAT XD Pressure Chart

Belt Width		No. Blades	Pressure	
in.	mm		psi	kPa
18	450	3	15	103
24	600	4	19	131
30	750	5	23	159
36	900	6	27	186
42	1050	7	31	214
48	1200	8	35	241
54	1350	9	39	269
60	1500	10	43	296
72	1800	12	51	352
84	2100	14	59	407
96	2400	16	67	462

Push-up Tensioning Instructions

1. **Disassemble guide kit.** Remove nuts and washers from both sides of tensioner (Fig. 1).
2. **Disassemble upper mounting plate and air bag.** Remove and save bushing nut. Remove and discard upper mounting plate. Remove (unscrew) and save air bag, threaded insert and support plate (Fig. 2).
Optional: Remove guide bushings and adjusting rod sleeves. It will not affect the tensioner if left in place.
3. **Remove and save top hat bracket and its hardware** (Fig. 3).
4. **Flip over PAT mounting bracket assembly.** The two flanges are now at the bottom.

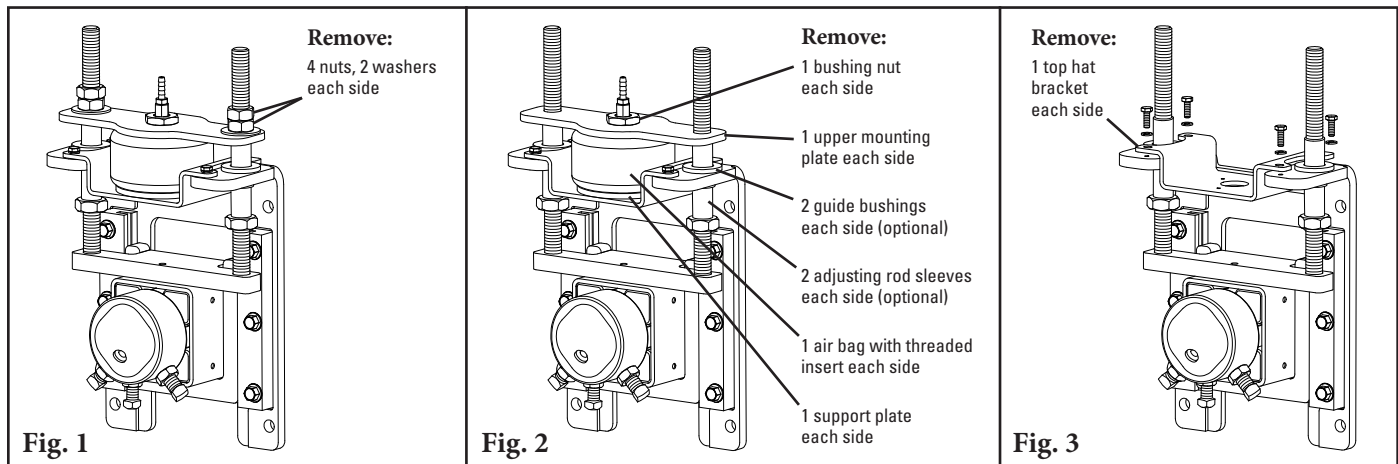

5. **Reassemble the SAT XD Tensioner.** Remove three screws from air bag support plate (Fig. 4). Turn the threaded insert into the support plate. Also turn part of the threaded insert into the hole on pole mount. (Fig. 4a). Ensure 1/4" (6mm) of threaded insert is still exposed, then turn the air bag onto the threaded insert and tighten (Fig. 5).
6. **Reassemble top hat bracket.** Ensure bracket is resting on flanges of mounting bracket. Screw sleeves into bushings and tighten locknuts (Fig. 6).
7. **Slide pole mount/threaded rods/air bag assembly down** with hose barb through hole in top hat bracket and reinstall bushing nut (Fig. 6).
8. **Complete the installation.** Follow steps 5 and 6 on page 1.

