

MHCP Precleaner

Installation, Operation and Maintenance Manual

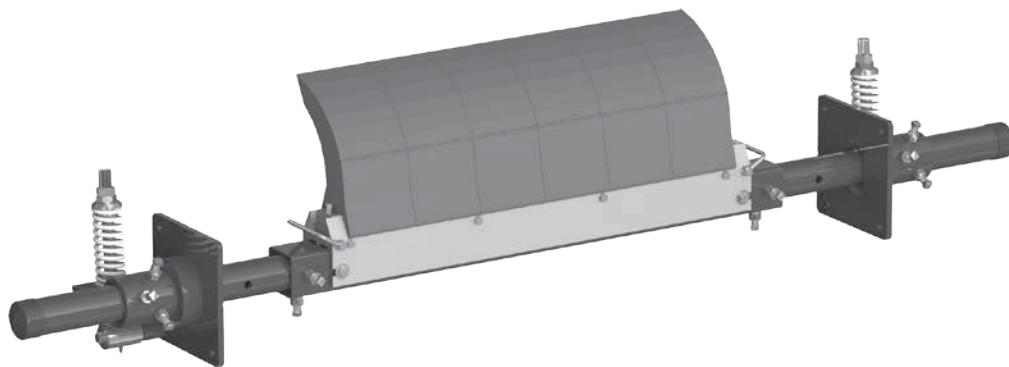

MHCP Precleaner

Serial Number: _____
Purchase Date: _____
Purchased From: _____
Installation Date: _____

Serial number information can be found on the Serial Number Label included in the Information Packet found in the cleaner carton.

This information will be helpful for any future inquiries or questions about belt cleaner replacement parts, specifications or troubleshooting.

Table of Contents

Section 1 – Important Information	2
1.1 General Introduction.....	2
1.2 User Benefits	2
1.3 Service Option.....	2
Section 2 – Safety Considerations and Precautions	3
2.1 Stationary Conveyors	3
2.2 Operating Conveyors	3
Section 3 – Pre-Installation Checks and Options	4
3.1 Checklist	4
3.2 Cleaner Location Adjustments.....	5
3.3 Optional Installation Accessories	6
Section 4 – Installation Instructions	7
Section 5 – Pre-Operation Checklist and Testing	11
5.1 Pre-Op Checklist	11
5.2 Test Run the Conveyor	11
Section 6 – Maintenance	14
6.1 New Installation Inspection.....	14
6.2 Routine Visual Inspection	14
6.3 Routine Physical Inspection.....	14
6.4 Blade Replacement Instructions	15
6.5 Maintenance Log.....	17
6.6 Cleaner Maintenance Checklist.....	18
Section 7 – Troubleshooting	19
Section 8 – Specs and CAD Drawings	20
8.1 Specifications and Guidelines.....	20
8.2 CAD Drawings.....	21
Section 9 – Replacement Parts	23
9.1 Replacement Parts List.....	23
9.2 Optional Assemblies, Tensioners & Kits.....	24
Section 10 – Other Flexco Conveyor Products	25

Section 1 – Important Information

1.1 General Introduction

We at Flexco are very pleased that you have selected a MHCP Precleaner for your conveyor system.

This manual will help you to understand the operation of this product and assist you in making it work up to its maximum efficiency over its lifetime of service.

It is essential for safe and efficient operation that the information and guidelines presented be properly understood and implemented. This manual will provide safety precautions, installation instructions, maintenance procedures and troubleshooting tips.

If, however, you have any questions or problems that are not covered, please visit our web site or contact our Customer Service Department:

Customer Service: 1-800-541-8028

Visit www.flexco.com for other Flexco locations and products.

Please read this manual thoroughly and pass it on to any others who will be directly responsible for installation, operation and maintenance of this cleaner. While we have tried to make the installation and service tasks as easy and simple as possible, **it does however require correct installation and regular inspections and adjustments to maintain top working condition.**

1.2 User Benefits

Correct installation and regular maintenance will provide the following benefits for your operation:

- Reduced conveyor downtime
- Reduced man-hour labor
- Lower maintenance budget costs
- Increased service life for the belt cleaner and other conveyor components

1.3 Service Option

The MHCP Precleaner is designed to be easily installed and serviced by your on-site personnel. However, if you would prefer complete turn-key factory service, please contact your local Flexco Field Representative.

Section 2 – Safety Considerations and Precautions

Before installing and operating the MHCP Precleaner, it is important to review and understand the following safety information. There are set-up, maintenance and operational activities involving both **stationary** and **operating** conveyors. Each case has a safety protocol.

2.1 Stationary Conveyors

The following activities are performed on stationary conveyors:

- Installation
- Blade replacement
- Repairs
- Tension adjustments
- Cleaning

DANGER

It is imperative that OSHA/MSHA Lockout/Tagout (LOTO) regulations, 29 CFR 1910.147, be followed before undertaking the preceding activities. Failure to use LOTO exposes workers to uncontrolled behavior of the belt cleaner caused by movement of the conveyor belt. Severe injury or death can result.

Before working:

- Lockout/Tagout the conveyor power source
- Disengage any takeups
- Clear the conveyor belt or clamp securely in place

WARNING

Use Personal Protective Equipment (PPE):

- Safety eyewear
- Hardhats
- Safety footwear

Close quarters, springs and heavy components create a worksite that compromises a worker's eyes, feet and skull.

PPE must be worn to control the foreseeable hazards associated with conveyor belt cleaners. Serious injuries can be avoided.

2.2 Operating Conveyors

There are two routine tasks that must be performed while the conveyor is running:

- Inspection of the cleaning performance
- Dynamic troubleshooting

DANGER

Every belt cleaner is an in-running nip hazard. Never touch or prod an operating cleaner. Cleaner hazards cause instantaneous amputation and entrapment.

WARNING

Belt cleaners can become projectile hazards. Stay as far from the cleaner as practical and use safety eyewear and headgear. Missiles can inflict serious injury.

WARNING

Never adjust anything on an operating cleaner. Unforeseeable belt projections and tears can catch on cleaners and cause violent movements of the cleaner structure. Flailing hardware can cause serious injury or death.

Section 3 – Pre-Installation Checks and Options

3.1 Checklist

- Check that the cleaner size is correct for the beltline width
- Check the belt cleaner carton and make sure all the parts are included
- Review the “Tools Needed” list on the top of the installation instructions
- Check the conveyor site:
 - Will the cleaner be installed on a chute
 - Are there obstructions that may require cleaner location adjustments (see 3.2 – Cleaner Location Adjustments)
 - Is the install on an open head pulley requiring mounting structure (see 3.3 – Optional Installation Accessories)

Section 3 – Pre-Installation Checks and Options

3.2 Cleaner Location Adjustments

In certain applications it is necessary to modify the location of the precleaner pole due to permanent obstacles that obstruct the desired location. Relocating the pole location can be done easily and does not hinder the performance of the cleaner as long as the “C” dimension is maintained.

NOTE: In the following example we will be lowering the pole location in the “Y” direction, but the same method could also be applied in the “X” direction.

Conveyor situation:

Pulley Diameter: 36"

X = 18"

Y = 14 3/8"

C = 23"

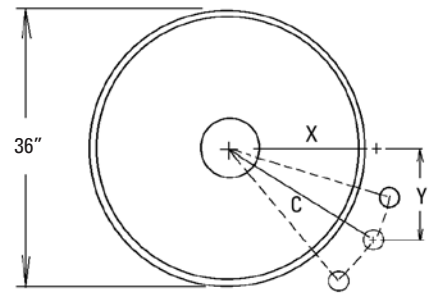

- Determine the given location dimensions and define the change needed.** After laying out the given X & Y dimensions, determine the distance of the modification required for adequate clearance of the pole and tensioning system. (In the example we decide to lower the pole 2" to clear the support structure).
- Write down known dimensions.** We can now determine two of the three required dimension which will allow us to find the third. We know we cannot alter the “C” dimension, so this will remain the same. Also we are required to lower the unit in the “Y” dimension 2", so we add 2" to the given “Y” dimension.

X = ?"

Y = 14 3/8 + 2 = 16 3/8"

C = 23"

- Determine final dimension.** On a flat vertical surface, using a level, draw one horizontal line and one vertical line creating a right triangle (Fig 3a). Measure down from the intersection the determined “Y” dimension and mark (Fig 3b). With the tape measure starting at the modified “Y” mark, swing the tape across the “X” line and mark at the “C” dimension where it crosses the “X” line (Fig 3c). Measure from the intersection to the “C” intersection and this will be your new “X” dimension (Fig 3d).

X = 16 1/8"

Y = 16 3/8"

C = 23"

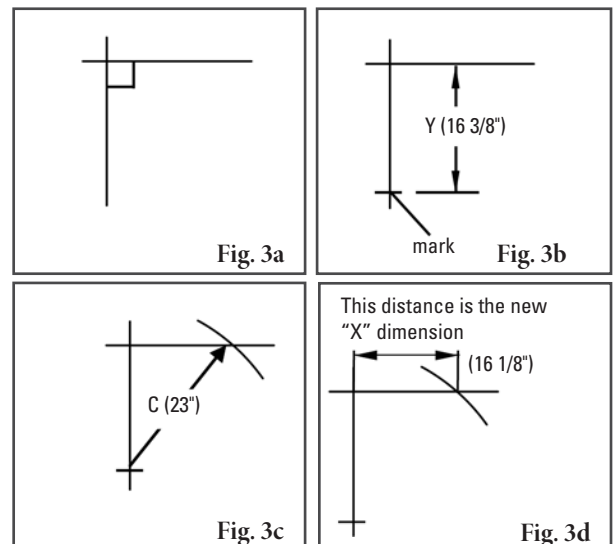

Section 3 - Pre-Installation Checks and Options

3.3 Optional Installation Accessories

Versatile, adjustable brackets and plates that can be mounted on the conveyor structure so precleaners and secondary cleaners can be easily and quickly bolted into place.



75830

Optional Mounting Bar Kit

(with bolts, nuts and washers)

- For mounting precleaners on open head pulleys.
- Weld on both sides of pulley and bolt on steel plates.
- 1-1/2" W x 16" L with (4) 5/8-11 tapped holes



76537

Optional Mounting Plate Kit

- For use with Mounting Bars to mount cleaners on open head pulleys.
- 16" x 32" (400 x 800mm) with (4) 5/8" holes

Optional Mounting Kits (incl. 2 brackets/bars)

Description	Ordering Number	Item Code	Wt. Lbs.
Optional Mounting Bar Kit *	MMBK	75830	19.5
Mounting Plate Kit (incl. 2 plates)	MMPK	76537	140.0

*Hardware Included
Lead time: 1 working day

Pole Extender Kit (incl. 2 pole extenders)

Description	Ordering Number	Item Code	Wt. Lbs.
Pole Extender Kit	MAPEK	76024	21.9

Provides 30" (750mm) of extended pole length.
Lead time: 1 working day

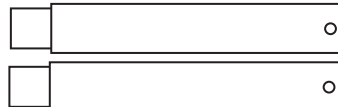

Section 4 – Installation Instructions

4.1 MHCP Precleaner

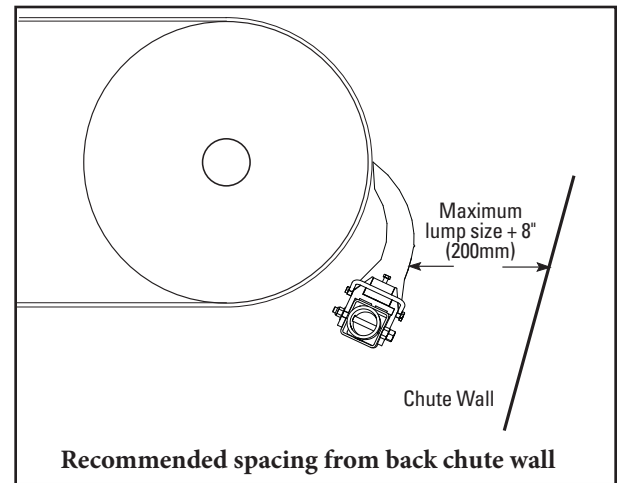
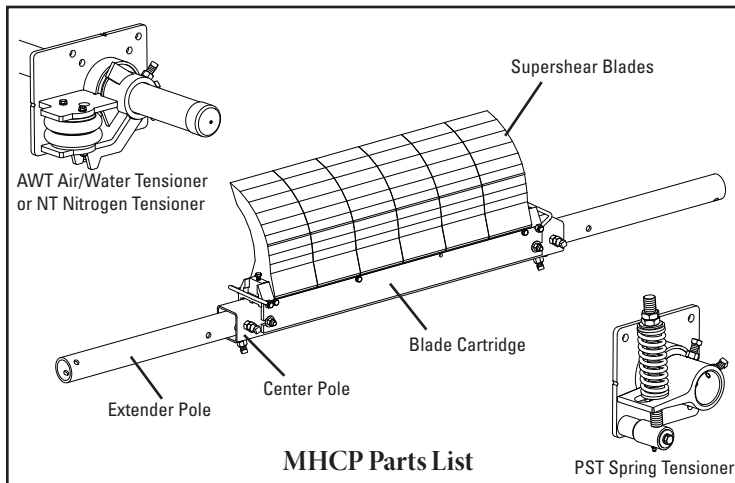

Physically lock out and tag the conveyor at the power source before you begin cleaner installation.

CAUTION: Components may be heavy. Use safety-approved lifting procedures.

- Tools Needed:**
- Tape Measure
 - Wrenches or Crescent Wrenches: (2) 3/4" (19mm), (2) 1-1/2" (38mm), (1) 15/16" (24mm), and (1) 5/8" (16mm)
 - C-clamps for AWT only

Blades per Cleaner Size

24"	30"	36"	42"	48"	54"	60"	72"	84"	96"
3	4	5	6	7	8	9	11	13	15

X & Y Chart for Pole Location

Pulley Diameter (including belt and lagging)	X	Y	C
20"	10"	14-3/8"	17-1/2"
21"	10-1/2"	14-3/8"	17-3/4"
22"	11"	14-3/8"	18-1/8"
23"	11-1/2"	14-3/8"	18-3/8"
24"	12"	14-3/8"	18-3/4"
25"	12-1/2"	14-3/8"	19"
26"	13"	14-3/8"	19-3/8"
27"	13-1/2"	14-3/8"	19-3/4"
28"	14"	14-3/8"	20-1/8"
29"	14-1/2"	14-3/8"	20-3/8"
30"	15"	14-3/8"	20-3/4"
31"	15-1/2"	14-3/8"	21-1/8"
32"	16"	14-3/8"	21-1/2"
33"	16-1/2"	14-3/8"	21-7/8"
34"	17"	14-3/8"	22-1/4"
35"	17-1/2"	14-3/8"	22-5/8"
36"	18"	14-3/8"	23"
37"	18-1/2"	14-3/8"	23-3/8"
38"	19"	14-3/8"	23-7/8"
39"	19-1/2"	14-3/8"	24-1/4"
40"	20"	14-3/8"	24-5/8"
41"	20-1/2"	14-3/8"	25"
42"	21"	14-3/8"	25-1/2"
43"	21-1/2"	14-3/8"	25-7/8"
44"	22-1/4"	14-3/8"	26-1/2"
45"	22-7/8"	14-3/8"	27"
46"	23-1/2"	14-3/8"	27-1/2"
47"	24"	14-3/8"	28"
48"	24-5/8"	14-3/8"	28-1/2"

- Find the X, Y & C specifications.** Measure the pulley diameter (including the belt and the lagging) (Fig. 1).
Pulley Diameter _____"; X= _____"; Y= _____"; C= _____".
(Adjustments can be made to the X & Y coordinates to move away from obstacles as long as the C dimension remains constant.)

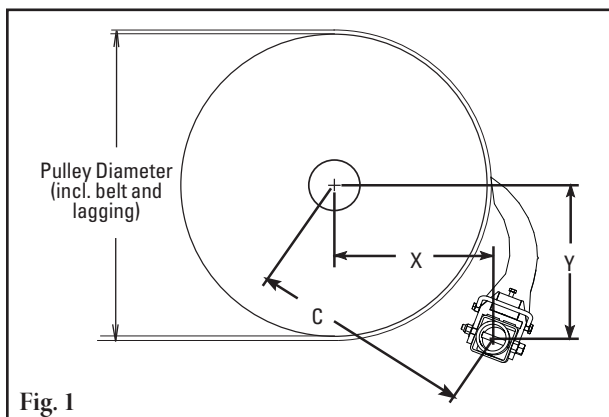

Section 4 – Installation Instructions

4.1 MHCP Precleaner (cont.)

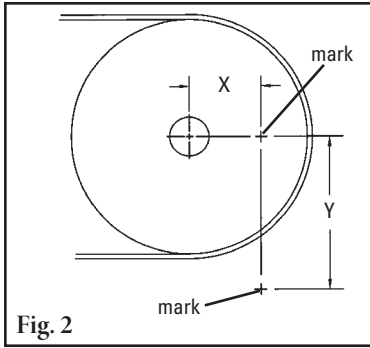

2. **Lay out the dimensions on the chute wall.** Measure out the X dimension horizontally from the center of the pulley shaft and mark. (NOTE: It may be easier to put a level on top of the pulley shaft, draw a horizontal line and then measure down half the diameter of the shaft and make a line from the front of the shaft. Now subtract half the pulley shaft diameter from the X coordinate and measure on the line and make a mark.) Then measure down vertically the Y dimension and mark. This is the correct position for the center of the cleaner pole (Fig. 2). Lay out and mark the same dimensions on the other side.

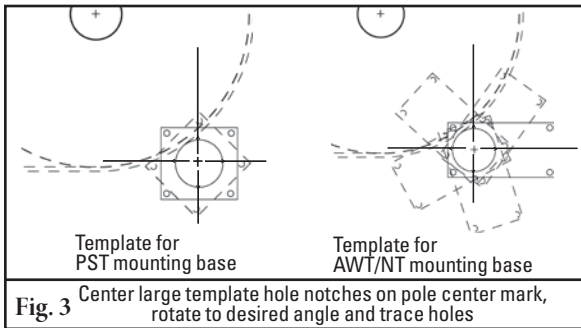

3. **Mark and cut the mounting base holes.** Using the mounting base template provided in the instruction packet, position the large pole hole of the template on the chute with the hole notches aligned with the layout lines. Trace the pole hole and mounting holes (Fig. 3). Each base can be mounted in any position 360° around the pole as long as the pole's center point does not change. Cut the holes on both sides of the chute.

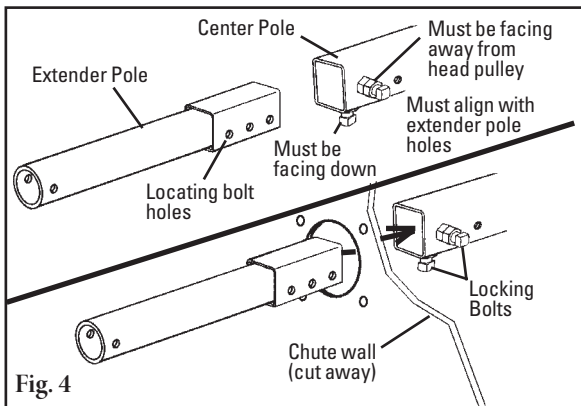

4. **Assemble the extender poles to the center pole.** Insert the extender poles through the chute holes and into the center pole and make sure the locating bolt holes align with the center pole holes (holes are offset to the lower half). Position the center pole with the welded nuts and locking bolts on one side facing down and on the adjoining side facing away from the head pulley (Fig. 4). Leave the locking bolts loose.

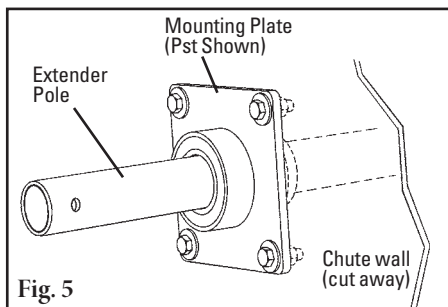
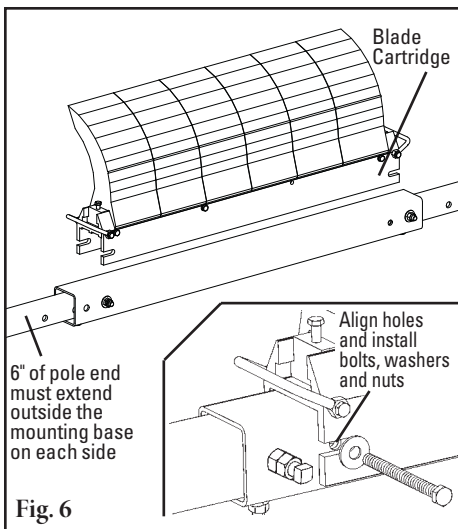

5. **Install the mounting bases.** Bolt the mounting bases to the chute with the bolts provided (Fig. 5).

6. **Install the blade cartridge.** Place the blade cartridge onto the center pole. Adjust the extender poles until the holes align with the holes in the center pole and lock the cartridge into place with the two bolts, washers and nuts (Fig. 6). NOTE: Be sure at least 6" of the extender pole extends out of the mounting base on each side for tensioner installation. Adjust the extender poles in the center pole if more or less length is needed.

Section 4 – Installation Instructions

4.1 MHCP Precleaner (cont.)

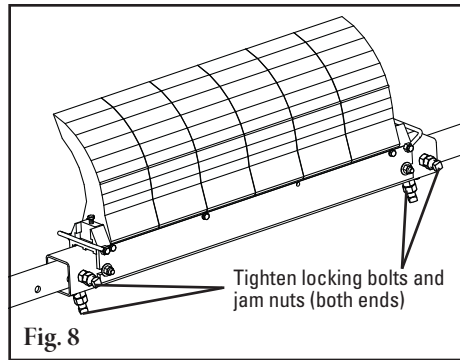
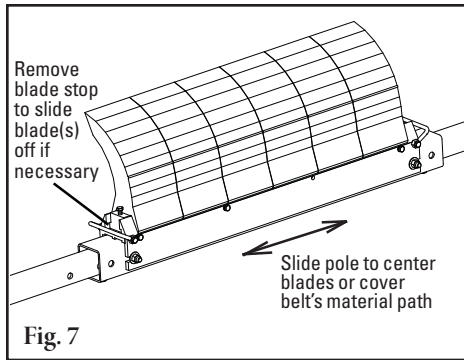

7. **Center the blades on the belt.** Slide the pole until the blades are centered or cover the belt's material path (Fig. 7). **NOTE:** Standard blade coverage is belt width minus 6". If less blade coverage is required, single blades can be removed from the blade cartridge. The blades do not have to be centered in the cartridge. They should be centered on the belt's material path.

8. **Lock the extender poles in the center pole.** Tighten the two locking bolts and jam nuts on each end of the center pole (Fig. 8). **Install the tensioning system.** For the PST Spring Tensioner go to step 9S. For the PAT Tensioner proceed to step 9P.

Precleaner Spring Tensioner (PST)

- 9S. **Install the torque pivot rod.** Remove the adjusting nuts and springs from the rods. The pivot rod base can be installed in any of the four mounting plate holes. Determine the rotation desired. Insert the pivot rod mounting bolt through the chute wall and the mounting plate and into the pivot rod base and tighten (Fig. 9S).

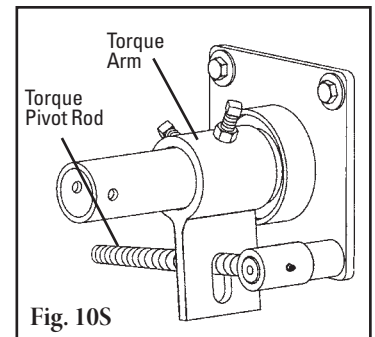
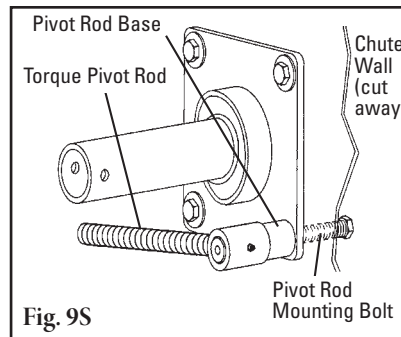

- 10S. **Slide the torque arm onto the pole end.** Again ensuring the correct pulling rotation, put the torque arm onto the pole end and rotate it around until the torque pivot rod slides through the slot (Fig. 10S).

- 11S. **Reassemble the spring assembly.** Slide the spring, washer and bushings onto the pivot rod and turn the two adjusting nuts so about 1/4" of the rod is exposed above the nuts (Fig. 11S). Complete steps 9S through 11S on the other side.

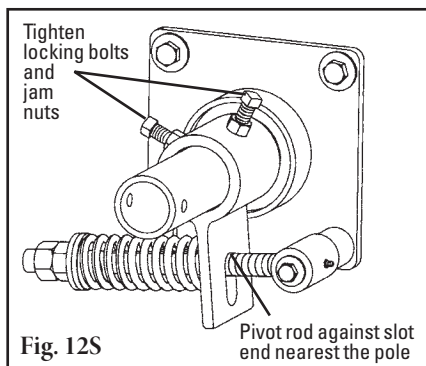
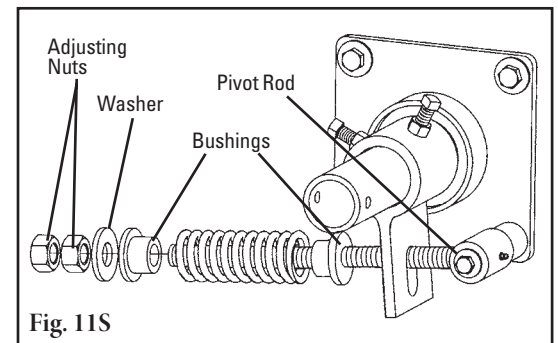

- 12S. **Tension the blades to the belt.** Rotate the blades until they contact the belt. While holding the spring bushing flat on the torque arm, rotate the torque arm until the pivot rod is against the end of the slot nearest the pole. Tighten the locking bolts and jam nuts on the torque arm (Fig. 12S). **NOTE:** The torque arm should be up against the mounting base.

Section 4 – Installation Instructions

4.1 MHCP Precleaner (cont.)

Spring Length Chart

Blade Width	No. Of Blades	White Springs	Silver Springs	Red Springs
18"	3	5 3/4"	6 3/8"	6 1/2"
24"	4	5 3/8"	6 1/4"	6 3/8"
30"	5	5 1/8"	6 1/8"	6 3/8"
36"	6	4 3/4"	6 1/8"	6 1/4"
42"	7	4 1/2"	6"	6 1/4"
48"	8	N/A	5 7/8"	6 1/8"
54"	9	N/A	5 3/4"	6 1/8"
60"	10	N/A	5 3/4"	6"
66"	11	N/A	5 5/8"	6"
72"	12	N/A	5 1/2"	5 7/8"
78"	13	N/A	5 1/8"	5 3/4"
84"	14	N/A	N/A	5 3/4"
90"	15	N/A	N/A	5 5/8"
96"	16	N/A	N/A	5 1/2"
102"	17	N/A	N/A	5 1/2"

Spring tension is based on the number of blades on the cleaner, not the belt width. Shading indicates preferred spring option.

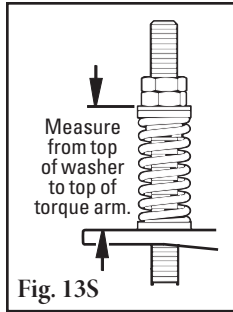

Fig. 13S

13S. Set the correct blade tension. Refer to the chart or the decal on the mounting base for the spring length required for the belt width. Lightly pull the pivot rod toward the end of the torque arm slot nearest the pole and turn the adjusting nuts until the required spring length is achieved (Fig. 13S). Complete steps 12S and 13S on the other side. For best results, recheck the spring length on the first side to insure there has been no movement.

14S. Test run the cleaner. Run the conveyor for at least 15 minutes and inspect cleaning performance. Check the spring lengths for proper tensioning. Make adjustments as necessary.

Portable Air Tensioner (PAT)

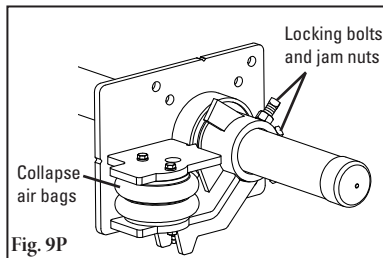

Fig. 9P

NOTE: Tensioners are shipped with the air bags and torque arms attached to the mounting bases.

9P. Tension the blades to the belt. Collapse both air bags (with C-clamps) and rotate the blades until they are 1" short of contact with the belt. Tighten the torque arm locking bolts and jam nuts (Fig. 9P).

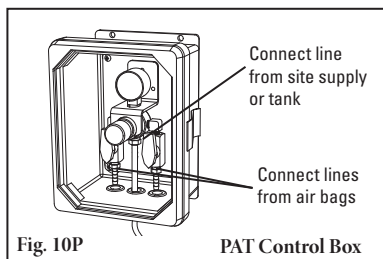

Fig. 10P

PAT Control Box

10P. Connect the supply lines and set tension pressure.

With the parts supplied, attach a line to each air bag and run the lines to the outlet side of the PAT control box (Fig. 10P). **NOTE:** Be sure lines are safely away from the belt. Connect a line from the inlet side of the box to the site's supply or air tank. Test the connections for leaks and set the pressure per the chart on the control box (also shown below). Take the pressure chart label from the instruction packet and affix it in an easily accessible location near the regulator for future reference.

Pressure Chart

Blade Width	No. of Blades	PSI
18"	3	8#
24"	4	10#
30"	5	13#
36"	6	15#
42"	7	18#
48"	8	20#
54"	9	23#
60"	10	25#
66"	11	28#
72"	12	31#
78"	13	33#
84"	14	36#
90"	15	38#

PSI setting is based on the number of blades on the cleaner, not the belt width.

11P. Test run the cleaner. Run the conveyor for at least 15 minutes and inspect cleaning performance. Make adjustments as necessary.

Section 5 – Pre-Operation Checklist and Testing

5.1 Pre-Op Checklist

- Recheck that all fasteners are tightened properly
- Add pole caps
- Apply all supplied labels to the cleaner
- Check the blade location on the belt
- Be sure that all installation materials and tools have been removed from the belt and the conveyor area

5.2 Test Run the Conveyor

- Run the conveyor for at least 15 minutes and inspect the cleaning performance
- Check the tensioner spring for recommended length (proper tensioning)
- Make adjustments as necessary

NOTE: Observing the cleaner when it is running and performing properly will help to detect problems or when adjustments are needed later.

Section 6 – Maintenance

Flexco belt cleaners are designed to operate with minimum maintenance. However, to maintain superior performance some service is required. When the cleaner is installed a regular maintenance program should be set up. This program will ensure that the cleaner operates at optimal efficiency and problems can be identified and fixed before the cleaner stops working.

All safety procedures for inspection of equipment (stationary or operating) must be observed. The MHCP Precleaner operates at the discharge end of the conveyor and is in direct contact with the moving belt. Only visual observations can be made while the belt is running. Service tasks can be done only with the conveyor stopped and by observing the correct lockout/tagout procedures.

6.1 New Installation Inspection

After the new cleaner has run for a few days a visual inspection should be made to ensure the cleaner is performing properly. Make adjustments as needed.

6.2 Routine Visual Inspection (every 2-4 weeks)

A visual inspection of the cleaner and belt can determine:

- If the spring length is the correct length for optimal tensioning.
- If the belt looks clean or if there are areas that are dirty.
- If the blade is worn out and needs to be replaced.
- If there is damage to the blade or other cleaner components.
- If fugitive material is built up on the cleaner or in the transfer area.
- If there is cover damage to the belt.
- If there is vibration or bouncing of the cleaner on the belt.
- If a snub pulley is used, a check should be made for material buildup on the pulley.

If any of the above conditions exist, a determination should be made on when the conveyor can be stopped for cleaner maintenance.

6.3 Routine Physical Inspection (every 6-8 weeks)

When the conveyor is not in operation and properly locked and tagged out a physical inspection of the cleaner to perform the following tasks:

- Clean material buildup off of the cleaner blade and pole.
- Closely inspect the blade for wear and any damage. Replace if needed.
- Check both cartridges for proper installation and condition. Replace if needed.
- Ensure full blade to belt contact.
- Inspect the cleaner pole for damage.
- Inspect all fasteners for tightness and wear. Tighten or replace as needed.
- Replace any worn or damaged components.
- Check the tension of the cleaner blade to the belt. Adjust the tension if necessary using the chart on the cleaner or the one on Page 10.
- When maintenance tasks are completed, test run the conveyor to ensure the cleaner is performing properly.

Section 6 – Maintenance

6.4 Blade Replacement Instructions

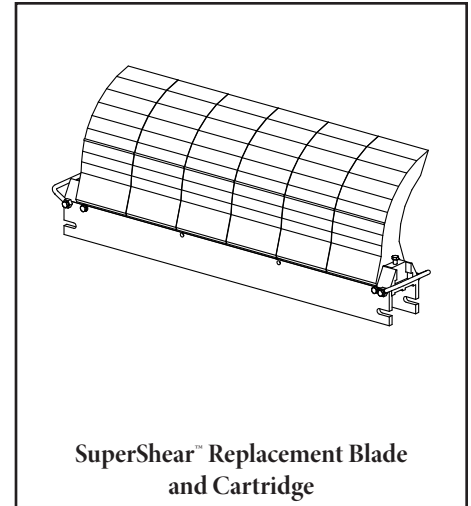
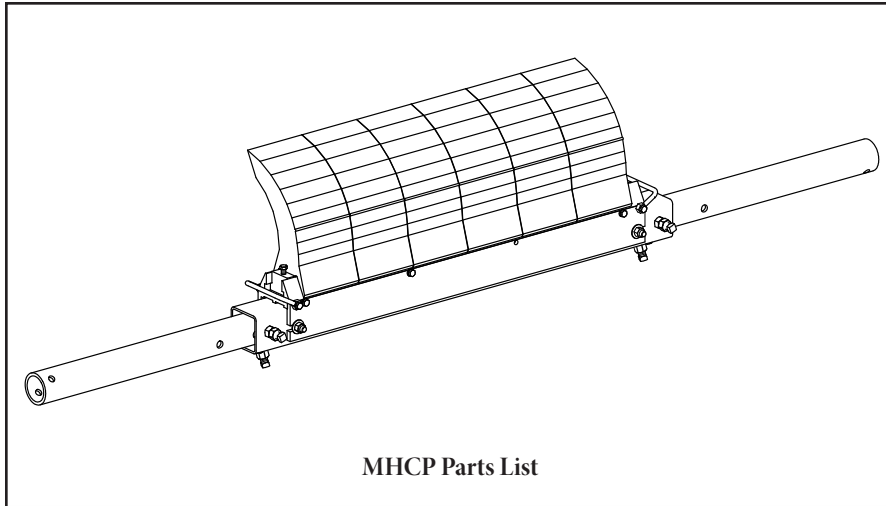

Physically lock out and tag the conveyor at the power source before you begin cleaner installation.

Tools Needed:

- Tape measure
- (2) 3/4" (19mm) wrench or crescent wrench
- 11/16" (17mm) wrench or crescent wrench
- (1) 9/16" (14mm) wrench or crescent wrench
- Wire brush (for cleaning pole)
- Small putty knife (for cleaning pole)

1. **Remove the tension.** Loosen the adjusting nuts on both sides and turn them out until they are flush with ends of the pivot arm (Fig. 1) or release pressure from PAT control unit. This releases the tension of the blade on the belt.
2. **Remove the worn blade cartridge.** Remove two bolts on each end of cartridge and remove the cartridge from the pole (Fig. 2). Clean all fugitive material from the pole.

NOTE: If cartridge is hard to remove use a screwdriver or hammer to loosen it and then remove.

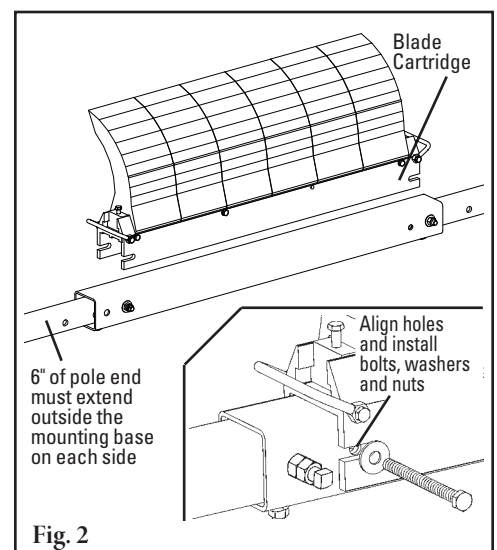
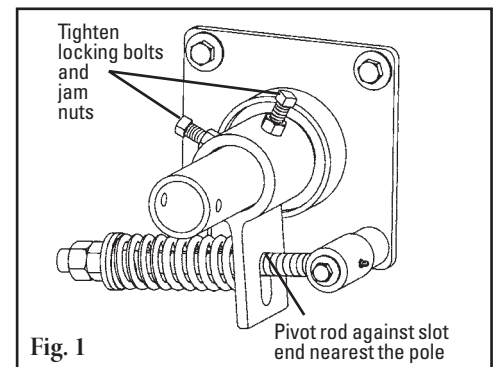

Section 6 – Maintenance

6.4 Blade Replacement Instructions (cont.)

3. **Change blades on cartridge.** Be sure to install all new blades to ensure even cleaning. To remove blades, unlock blade stop, remove handle and loosen cartridge expansion bolts. Clean cartridge before installing new blades. Install new blades then tighten cartridge expansion bolts and reinstall blade stop handle (Fig. 3).

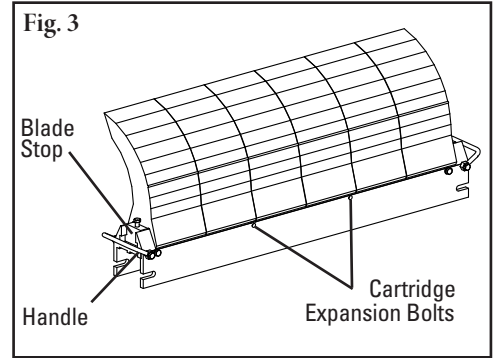

4. **Install the new cartridge.** Slide the new cartridge onto the pole. Align holes on pole and cartridge then install bolts, washers and nuts to lock in cartridge (Fig. 4).

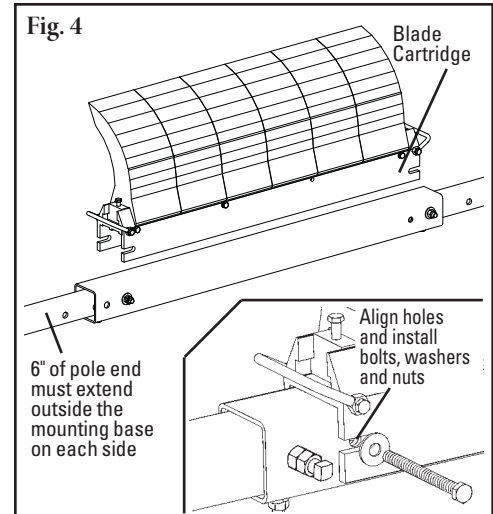

5. **Reset the correct blade tension.** Refer to the chart for the spring length/PSI required for the belt width. For PST lightly pull the pivot arm toward the end of the torque arm slot nearest the pole and turn the adjusting nuts until the required spring length is achieved (Fig. 5). Tighten jam nut. **NOTE:** The chart is also on the cleaner's pivot shaft bracket for future reference for retensioning maintenance.

Spring Length Chart

Blade Width	No. Of Blades	White Springs	Silver Springs	Red Springs
18"	3	5 3/4"	6 3/8"	6 1/2"
24"	4	5 3/8"	6 1/4"	6 3/8"
30"	5	5 1/8"	6 1/8"	6 3/8"
36"	6	4 3/4"	6 1/8"	6 1/4"
42"	7	4 1/2"	6"	6 1/4"
48"	8	N/A	5 7/8"	6 1/8"
54"	9	N/A	5 3/4"	6 1/8"
60"	10	N/A	5 3/4"	6"
66"	11	N/A	5 5/8"	6"
72"	12	N/A	5 1/2"	5 7/8"
78"	13	N/A	5 1/8"	5 3/4"
84"	14	N/A	N/A	5 3/4"
90"	15	N/A	N/A	5 5/8"
96"	16	N/A	N/A	5 1/2"
102"	17	N/A	N/A	5 1/2"

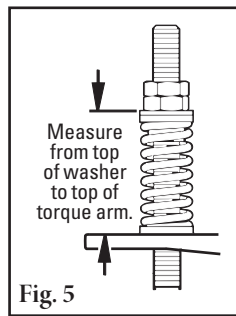

Pressure Chart

Blade Width	No. of Blades	PSI
18"	3	8#
24"	4	10#
30"	5	13#
36"	6	15#
42"	7	18#
48"	8	20#
54"	9	23#
60"	10	25#
66"	11	28#
72"	12	31#
78"	13	33#
84"	14	36#
90"	15	38#

PSI setting is based on the number of blades on the cleaner, not the belt width.

Spring tension is based on the number of blades on the cleaner, not the belt width. Shading indicates preferred spring option.

Test run the cleaner. Run the conveyor for at least 15 minutes and inspect the cleaning performance. Check the spring length for proper tensioning. Make adjustments as necessary.

Section 6 – Maintenance

6.5 Maintenance Log

Conveyor Name/No. _____

Date: _____ Work done by: _____ Service Quote # _____

Activity: _____

Date: _____ Work done by: _____ Service Quote # _____

Activity: _____

Date: _____ Work done by: _____ Service Quote # _____

Activity: _____

Date: _____ Work done by: _____ Service Quote # _____

Activity: _____

Date: _____ Work done by: _____ Service Quote # _____

Activity: _____

Date: _____ Work done by: _____ Service Quote # _____

Activity: _____

Date: _____ Work done by: _____ Service Quote # _____

Activity: _____



Section 6 – Maintenance

6.6 Cleaner Maintenance Checklist

Site: _____ Inspected by: _____ Date: _____

Belt Cleaner: _____ Serial Number: _____

Beltline Information:

Beltline Number: _____ Belt Condition: _____

Belt Width: 24" (600mm) 30" (750mm) 36" (900mm) 42" (1050mm) 48" (1200mm) 54" (1350mm) 60" (1500mm) 72" (1800mm) 84" (2100mm) 96"

Head Pulley Diameter (Belt & Lagging): _____ Belt Speed: _____ fpm Belt Thickness: _____

Belt Splice _____ Condition of Splice _____ Number of splices _____ Skived Unskived

Material conveyed _____

Days per week run _____ Hours per day run _____

Blade Life:

Date blade installed: _____ Date blade inspected: _____ Estimated blade life: _____

Is blade making complete contact with belt? Yes No

Distance from wear line: LEFT _____ MIDDLE _____ RIGHT _____

Blade condition: Good Grooved Smiled Not contacting belt Damaged

Measurement of spring: Required _____ Currently _____

Was Cleaner Adjusted: Yes No

Pole Condition: Good Bent Worn

Lagging: Slide lag Ceramic Rubber Other None

Condition of lagging: Good Bad Other _____

Cleaner's Overall Performance: (Rate the following 1 - 5, 1 = very poor - 5 = very good)

Appearance: Comments: _____

Location: Comments: _____

Maintenance: Comments: _____

Performance: Comments: _____

Other Comments: _____

Section 7 – Troubleshooting

Problem	Possible Cause	Possible Solutions
Poor cleaning performance	Cleaner under-tensioned	Adjust to correct tension – see spring length/PSI chart
	Cleaner over-tensioned	Adjust to correct tension – see spring length/PSI chart
	Cleaner installed in wrong location	Verify "C" dimension, relocate to correct dimension
	Cleaner blade worn or damaged	Replace cleaner blade
Rapid Blade Wear	Tension on cleaner too high/low	Adjust to correct tension – see spring length/PSI chart
	Cleaner not located correctly	Check cleaner location for correct dimensions
	Blade attack angle incorrect	Check cleaner location for correct dimensions
	Material too abrasive for blade	Option: switch to alternate cleaner with metal blades
	Mechanical splice damaging blade	Repair, skive or replace splice
Center wear on blade (smile effect)	Blade wider than material path	Replace blade with width to match material path
	Tension on cleaner too high/low	Adjust to correct tension – see spring length/PSI chart
Unusual wear or damage to blade	Mechanical splice damaging blade	Repair, skive or replace splice
	Belt damaged or ripped	Repair or replace belt
	Cleaner not correctly located	Verify "C" dimension, relocate to correct dimension
	Damage to pulley or pulley lagging	Repair or replace pulley
Vibration or noise	Cleaner not located correctly	Verify "C" dimension, relocate to correct dimension
	Blade attack angle incorrect	Verify "C" dimension, relocate to correct dimension
	Cleaner running on empty belt	Use a spray pole when the belt is empty
	Cleaner tension too high/low	Adjust to correct tension or slight adjust to diminish
	Cleaner locking bolts not secure	Check and tighten all bolts and nuts
	Cleaner not square to head pulley	Verify "C" dimension, relocate to correct dimension
	Material buildup in chute	Clean up build-up on cleaner and in chute
Cleaner being pushed away from pulley	Cleaner tension not set correctly	Ensure correct tension/increase tension slightly
	Sticky material is overburdening cleaner	Increase tension; replace with cleaner with metal tips; replace with larger size cleaner
	Cleaner not set up correctly	Confirm location dimensions are equal on both sides

Section 8 – Specs and CAD Drawings

8.1 Specifications & Guidelines

Telescoping Pole Length Specifications

Cleaner Size		Max Overall Pole Length		Center Pole Length		Maximum Conveyor Span	
in.	mm	in.	mm	in.	mm	in.	mm
24	600	82	2050	28	700	66	1650
30	750	88	2200	34	850	72	1800
36	900	94	2350	40	1000	78	1950
42	1050	100	2500	46	1150	84	2100
48	1200	106	2650	52	1300	90	2250
54	1350	112	2800	58	1450	96	2400
60	1500	118	2950	64	1600	102	2550
72	1800	130	3250	76	1900	114	2850
84	2100	142	3550	88	2200	126	3150
96	2400	154	3850	100	2500	138	3450

Pole Diameter - 2-7/8" (73mm)

Clearance Guidelines for Installation

Horizontal Clearance Required		Vertical Clearance Required	
in.	mm	in.	mm
7	175	19	475

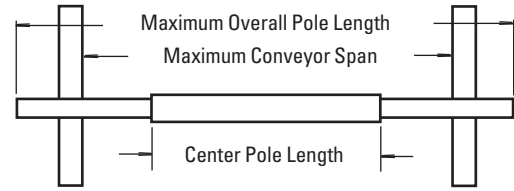
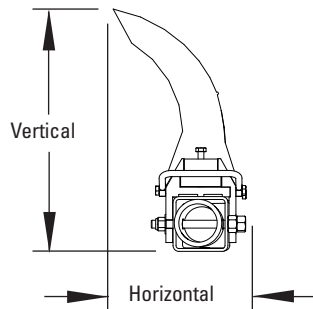

Pole Location Specs

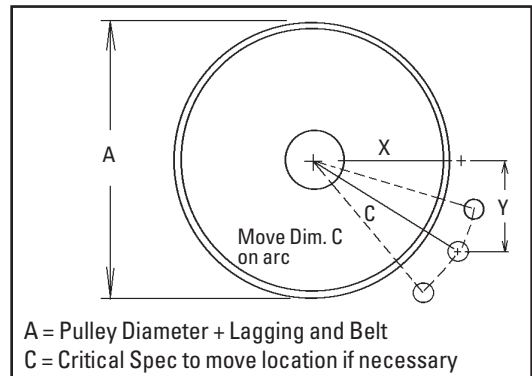

Spring Length Chart

Blade Width	No. of Blades	White Springs	Silver Springs	Red Springs
18"	3	5 3/4"	6 3/8"	6 1/2"
24"	4	5 3/8"	6 1/4"	6 3/8"
30"	5	5 1/8"	6 1/8"	6 3/8"
36"	6	4 3/4"	6 1/8"	6 1/4"
42"	7	4 1/2"	6"	6 1/4"
48"	8	N/A	5 7/8"	6 1/8"
54"	9	N/A	5 3/4"	6 1/8"
60"	10	N/A	5 3/4"	6"
66"	11	N/A	5 5/8"	6"
72"	12	N/A	5 1/2"	5 7/8"
78"	13	N/A	5 1/8"	5 3/4"
84"	14	N/A	N/A	5 3/4"
90"	15	N/A	N/A	5 5/8"
96"	16	N/A	N/A	5 1/2"
102"	17	N/A	N/A	5 1/2"

Spring tension is based on the number of blades on the cleaner, not the belt width. Shading indicates preferred spring option.

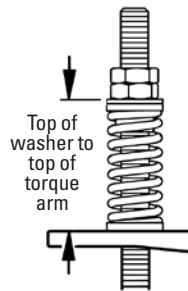

Pressure Chart

Blade Width	No. of Blades	PSI
18"	3	8#
24"	4	10#
30"	5	13#
36"	6	15#
42"	7	18#
48"	8	20#
54"	9	23#
60"	10	25#
66"	11	28#
72"	12	31#
78"	13	33#
84"	14	36#
90"	15	38#

PSI setting is based on the number of blades on the cleaner, not the belt width.

Pole Location Chart

A	X	Y	C
20"	10"	14 3/8"	17 1/2"
21"	10 1/2"	14 3/8"	17 3/4"
22"	11"	14 3/8"	18 1/8"
23"	11 1/2"	14 3/8"	18 3/8"
24"	12"	14 3/8"	18 3/4"
25"	12 1/2"	14 3/8"	19"
26"	13"	14 3/8"	19 3/8"
27"	13 1/2"	14 3/8"	19 3/4"
28"	14"	14 3/8"	20 1/8"
29"	14 1/2"	14 3/8"	20 3/8"
30"	15"	14 3/8"	20 3/4"
31"	15 1/2"	14 3/8"	21 1/8"
32"	16"	14 3/8"	21 1/2"
33"	16 1/2"	14 3/8"	21 7/8"
34"	17"	14 3/8"	22 1/4"
35"	17 1/2"	14 3/8"	22 5/8"
36"	18"	14 3/8"	23"
37"	18 1/2"	14 3/8"	23 3/8"
38"	19"	14 3/8"	23 7/8"
39"	19 1/2"	14 3/8"	24 1/4"
40"	20"	14 3/8"	24 5/8"
41"	20 1/2"	14 3/8"	25"
42"	21"	14 3/8"	25 1/2"
43"	21 1/2"	14 3/8"	25 7/8"
44"	22-1/4"	14-3/8"	26-1/2"
45"	22-7/8"	14-3/8"	27"
46"	23-1/2"	14-3/8"	27-1/2"
47"	24"	14-3/8"	28"
48"	24-5/8"	14-3/8"	28-1/2"

Specifications:

- Maximum Belt Speed 1200 FPM (6M/sec)
- Temperature Rating -30°F to 180°F (-35°C to 82°C)
- Minimum Pulley Diameter 20" (500mm)
- Blade Height 14" (350mm)
- Usable Blade Wear Length 8" (200mm)
- Blades Polyurethane (proprietary blend for abrasion resistance and long wear).
- Available for Belt Widths 24" to 96" (600 to 2400mm).
Other sizes available upon request.
- CEMA Cleaner Rating Class 5

Section 8 – Specs and CAD Drawings

8.2 CAD Drawing - MHCP PST

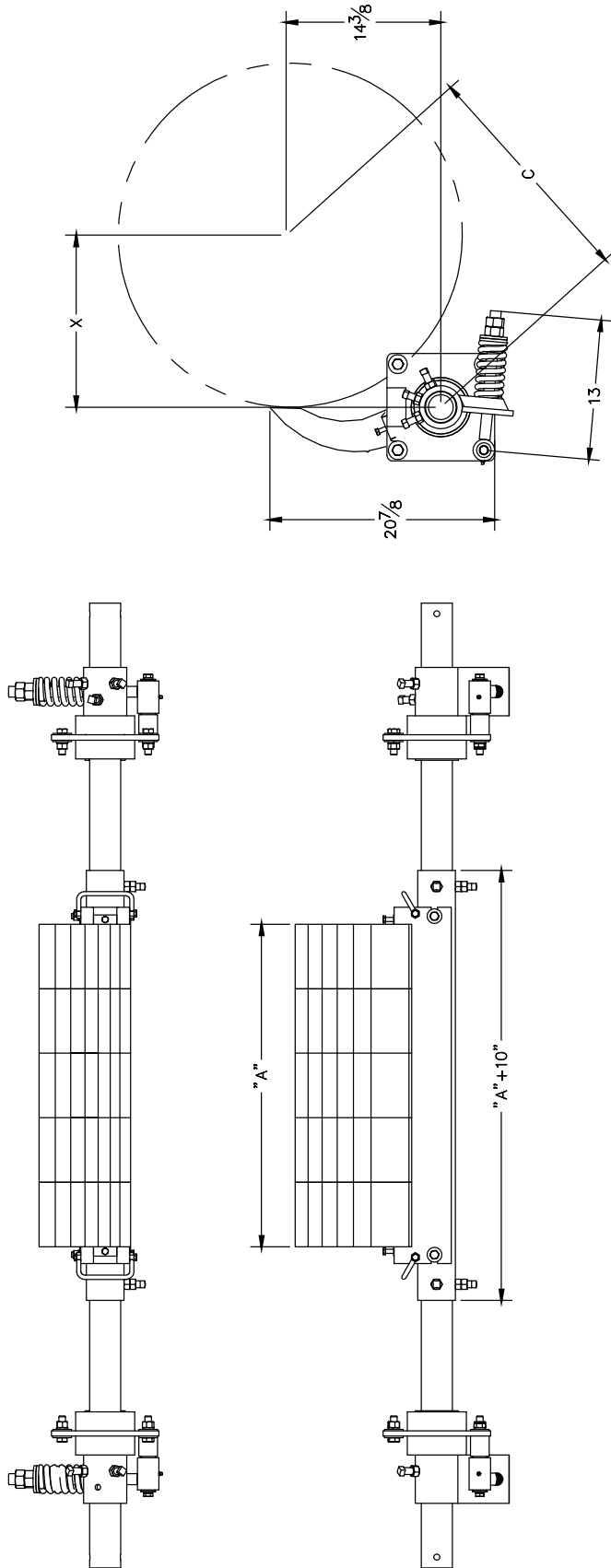

Pole Location Chart

A	X	Y	C
20"	10"	14-3/8"	17 1/2"
21"	10 1/2"	14-3/8"	17 3/4"
22"	11"	14-3/8"	18 1/8"
23"	11 1/2"	14-3/8"	18 3/8"
24"	12"	14-3/8"	18 3/4"
25"	12 1/2"	14-3/8"	19"
26"	13"	14-3/8"	19 3/8"
27"	13 1/2"	14-3/8"	19 3/4"
28"	14"	14-3/8"	20 1/8"
29"	14 1/2"	14-3/8"	20 3/8"
30"	15"	14-3/8"	20 3/4"
31"	15 1/2"	14-3/8"	21 1/8"
32"	16"	14-3/8"	21 1/2"
33"	16 1/2"	14-3/8"	21 7/8"
34"	17"	14-3/8"	22 1/4"
35"	17 1/2"	14-3/8"	22 5/8"
36"	18"	14-3/8"	23"
37"	18 1/2"	14-3/8"	23 3/8"
38"	19"	14-3/8"	23 7/8"
39"	19 1/2"	14-3/8"	24 1/4"
40"	20"	14-3/8"	24 5/8"
41"	20 1/2"	14-3/8"	25"
42"	21"	14-3/8"	25 1/2"
43"	21 1/2"	14-3/8"	25 7/8"
44"	22-1/4"	14-3/8"	26-1/2"
45"	22-7/8"	14-3/8"	27"
46"	23-1/2"	14-3/8"	27-1/2"
47"	24"	14-3/8"	28"
48"	24-5/8"	14-3/8"	28-1/2"

Cleaner	Belt Width	"A"	NO. OF BLADES
75929	24"	18"	3
75930	30"	24"	4
75931	36"	30"	5
75932	42"	36"	6
75933	48"	42"	7
75934	54"	48"	8
75935	60"	54"	9
75936	72"	66"	11
76800	84"	78"	13
78955	96"	90"	15

Section 8 – Specs and CAD Drawings

8.2 CAD Drawing - MHCP PAT

SPECIFICATION			MHCP PAT PRECLEANER		CENTER POLE		CARTRIDGE		
BELT WIDTH 'A'	MAX POLE LENGTH 'B'		ORDER NUMBER	ITEM CODE	ORDER NUMBER	ITEM CODE	ORDER NUMBER	ITEM CODE	
	(in)	(mm)							
		NUMBER OF BLADES 'C'							
[24]	[600]	[82]	[2080]	[3]	[MHCP-24P]	[78723]	[MHP-CP24]	[MHCP-2BC24]	[76638]
[30]	[750]	[88]	[2230]	[4]	[MHCP-30P]	[78724]	[MHP-CP30]	[MHCP-2BC30]	[76639]
[36]	[900]	[94]	[2380]	[5]	[MHCP-36P]	[78725]	[MHP-CP36]	[MHCP-2BC36]	[76640]
[42]	[1050]	[100]	[2530]	[6]	[MHCP-42P]	[78726]	[MHP-CP42]	[MHCP-2BC42]	[76488]
[48]	[1200]	[106]	[2680]	[7]	[MHCP-48P]	[78727]	[MHP-CP48]	[MHCP-2BC48]	[76489]
[54]	[1350]	[112]	[2830]	[8]	[MHCP-54P]	[78728]	[MHP-CP54]	[MHCP-2BC54]	[76490]
[60]	[1500]	[118]	[3000]	[9]	[MHCP-60P]	[78729]	[MHP-CP60]	[MHCP-2BC60]	[76491]
[72]	[1800]	[130]	[3300]	[11]	[MHCP-72P]	[78730]	[MHP-CP72]	[MHCP-2BC72]	[76493]
[84]	[2100]	[142]	[3600]	[13]	[MHCP-84P]	[78731]	[MHP-CP84]	[MHCP-2BC84]	[76697]
[96]	[2400]	[154]	[3900]	[15]	[MHCP-96P]	[78959]	[MHP-CP94]	[MHCP-2BC96]	[78986]
[108]	[2700]	[166]	[4150]	[17]	[MHCP-108P]	[90169]	[MHP-CP108]	[MHCP-2BC108]	[90413]
[120]	[3000]	[178]	[4450]	[19]	[MHCP-120P]	[90170]	[MHP-CP120]	[MHCP-2BC120]	[90414]

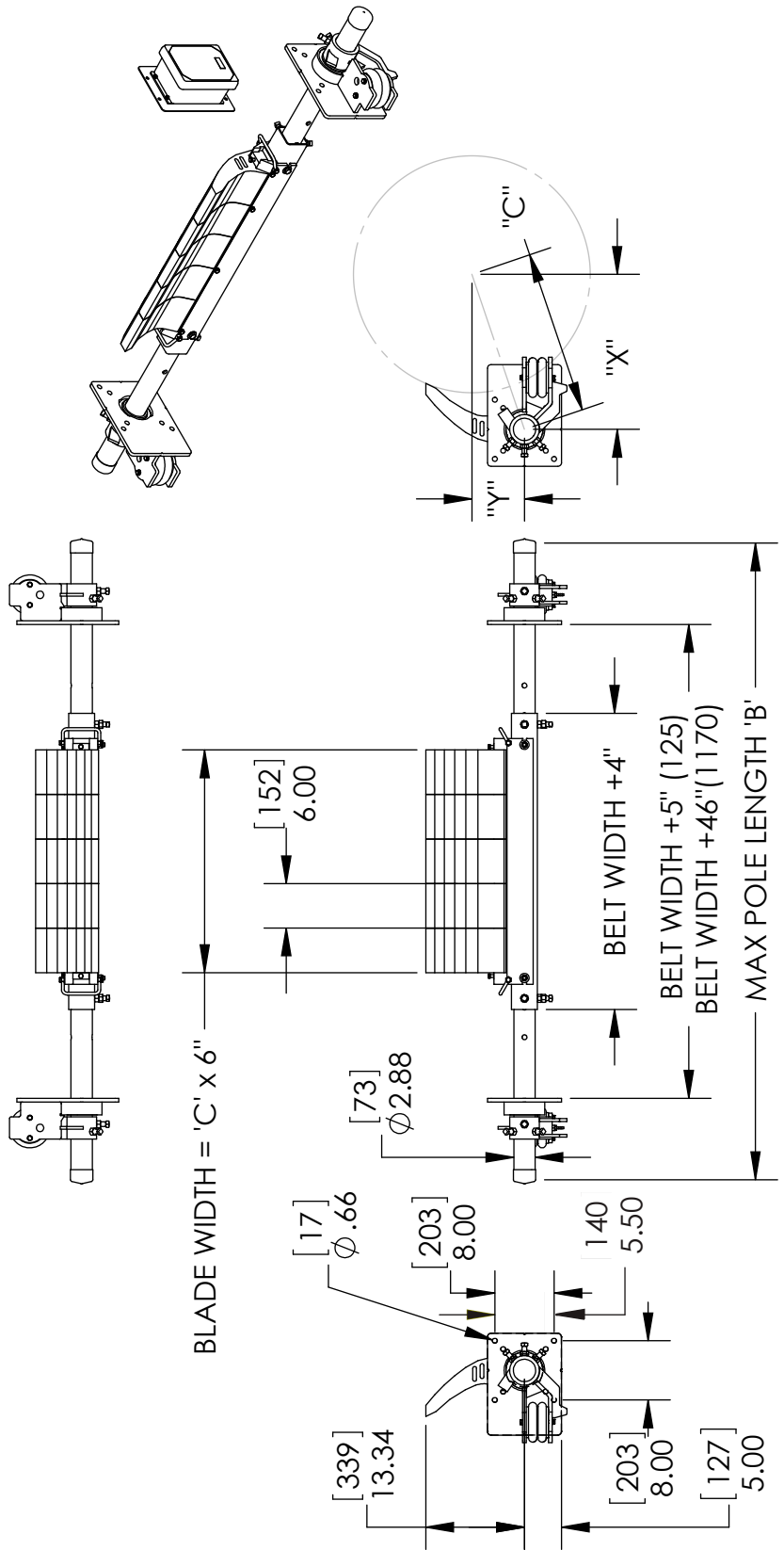

Section 9 – Replacement Parts

9.1 Replacement Parts List

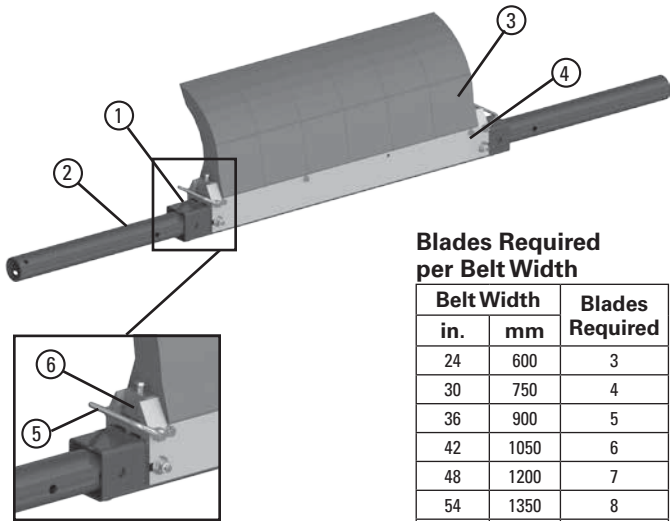

Blades Required per Belt Width

Belt Width		Blades Required
in.	mm	
24	600	3
30	750	4
36	900	5
42	1050	6
48	1200	7
54	1350	8
60	1500	9
72	1800	11
84	2100	13
96	2400	15

Blades and cartridges can be purchased separately (see chart at right) or preassembled as a Blade Cartridge Kit.

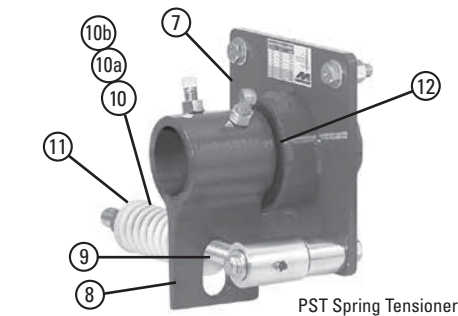

PST Spring Tensioner

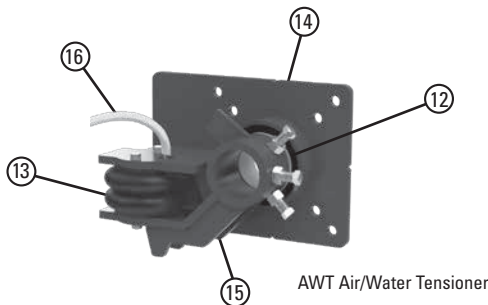

AWT Air/Water Tensioner

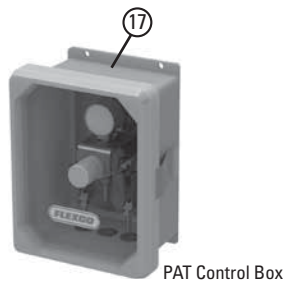

PAT Control Box

Replacement Parts

Ref	Description	Ordering Number	Item Code	Wt. Lbs.
1	24" (600mm) Center Pole *	MHP-CP24	75961	19.0
	30" (750mm) Center Pole *	MHP-CP30	75962	23.1
	36" (900mm) Center Pole *	MHP-CP36	75963	27.2
	42" (1050mm) Center Pole *	MHP-CP42	75964	31.2
	48" (1200mm) Center Pole *	MHP-CP48	75965	35.3
	54" (1350mm) Center Pole *	MHP-CP54	75966	39.4
	60" (1500mm) Center Pole *	MHP-CP60	75967	43.5
	72" (1800mm) Center Pole *	MHP-CP72	75968	51.6
	84" (2100mm) Center Pole *	MHP-CP84	76811	60.2
96" (2400mm) Center Pole *	MHP-CP96	78958	68.8	
2	MHCP Extender Poles (2 ea.)	MHP-EP	76392	54.0
3	SuperShear™ Blade	SSRB	75978	6.6
4	24" (600mm) 2-Piece Blade Cartridge *	MHCP-2BC24	76638	13.2
	30" (750mm) 2-Piece Blade Cartridge *	MHCP-2BC30	76639	17.6
	36" (900mm) 2-Piece Blade Cartridge *	MHCP-2BC36	76640	22.0
	42" (1050mm) 2-Piece Blade Cartridge *	MHCP-2BC42	76641	26.4
	48" (1200mm) 2-Piece Blade Cartridge *	MHCP-2BC48	76642	30.8
	54" (1350mm) 2-Piece Blade Cartridge *	MHCP-2BC54	76643	35.2
	60" (1500mm) 2-Piece Blade Cartridge *	MHCP-2BC60	76644	39.6
	72" (1800mm) 2-Piece Blade Cartridge *	MHCP-2BC72	76645	48.4
	84" (2100mm) 2-Piece Blade Cartridge *	MHCP-2BC84	76812	56.5
96" (2400mm) 2-Piece Blade Cartridge *	MHCP-2BC96	78986	64.6	
5	MHCP Cartridge Handle *	MHCP-CH	76393	0.4
6	MHCP Cartridge Blade Stop *	MHCP-BS	76394	0.4

*Hardware Included

PST Spring Tensioner Replacement Parts

Ref	Description	Ordering Number	Item Code	Wt. Lbs.
7	Mounting Plate Kit * (2 ea.)	MHPMPK	77727	44.4
8	Torque Arm * (1 ea.)	PSTA	75896	11.4
9	Torque Pivot Kit (1 ea.) (no spring)	PTPK	75897	7.0
10	Tension Spring - White (1 ea.) for belts 24" - 48" (600-1200mm)	PSTS-W	75898	1.7
10a	Tension Spring - Silver (1 ea.) for belts 54" - 84" (1350-2100mm)	PSTS-S	75899	3.0
10b	Tension Spring - Red (1 ea.) for belts 96" (2400mm)	PTS-R	77726	3.0
11	Bushing Kit (2 ea.) (for White, Silver, & Red Tensioners)	QMTBK-W	76098	0.2
12	Pole Bearing Assy (for cleaners shipped after 4/2016)	AWTPBA	90000	2.3
-	PST Spring Tensioner* - White (includes 2 each items 7, 8, 9, 10 & 11) for belts 24" - 48" (600-1200mm)	PST2-W	77723	86.1
-	PST Spring Tensioner* - Silver (includes 2 each items 7, 8, 9, 10a & 11) for belts 54" - 84" (1350-2100mm)	PST2-S	77724	86.2
-	PST Spring Tensioner* - Red (incl. 2 each items 7, 8, 9, 10b & 11 for belts 96" (2400mm)	PST-R	77725	86.2

*Hardware Included

PAT Tensioner Replacement Parts

Ref	Description	Ordering Number	Item Code	Wt. Lbs.
13	Air/Water Bag (1 ea.)	AWTB	75905	3.8
14	Mounting Base (1 ea.)	AWTMB	75906	22.9
15	Torque Arm * (1 ea.)	AWTA	75907	11.6
16	Hose Kit (50' of hose and 6 hose clamps)	AWTHK	75909	6.7
-	AWT Air/Water Tensioner w/o Control Box (includes 2 each items 13, 14, 15 & 1 each item 16)	AWTNCB	76069	75.2
17	PAT Control Box	PACB	78683	11.0
-	PAT Kit- AWT Tensioner w/ Control Box (includes 2 ea. Items 13,14, 15, 16 & 1 ea. Item 17)	PAK	78705	86.2

*Hardware Included



Section 9 – Replacement Parts

9.2 Optional Assemblies, Tensioners & Kits

Blade/Pole Assemblies (Includes blades, cartridge, center pole and 2 extender poles)

Belt Width		Ordering Number	Item Code	Wt. Lbs.
in.	mm			
24	600	MHCP-BPA24	75945	106.0
30	750	MHCP-BPA30	75946	121.1
36	900	MHCP-BPA36	75947	136.2
42	1050	MHCP-BPA42	75948	151.2
48	1200	MHCP-BPA48	75949	166.3
54	1350	MHCP-BPA54	75950	181.4
60	1500	MHCP-BPA60	75951	196.5
72	1800	MHCP-BPA72	75952	226.6
84	2100	MHCP-BPA84	76809	264.4
96	2400	MHCP-BPA96	78956	302.2

Lead time: 1 working day

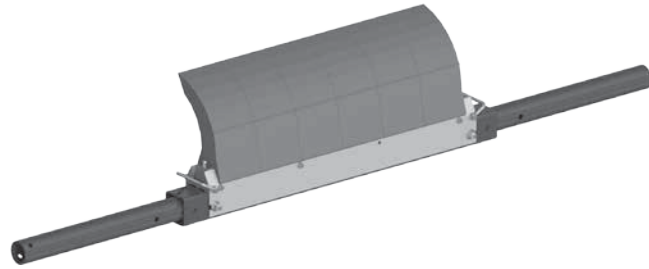

Tensioners (Includes tensioners for both pole ends)

Description	Ordering Number	Item Code	Wt. Lbs.
PST Spring Tensioner - White for belts 24" - 48" (600-1200mm)	PST-W	75893	86.1
PST Spring Tensioner - Silver for belts 54" - 84" (1350-2100mm)	PST-S	75894	86.2
PST Spring Tensioner - Red for belts 96" (2400mm)	PST2-R	77725	86.2
PAT Kit- AWT Tensioner w/ Control Box	PAK	78705	86.2

Lead time: 1 working day



PST Spring Tensioner

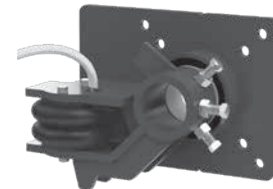

PAT Kit - AWT Air/Water Tensioner and Control Box

Blade Cartridge Kits (Includes blades, cartridge, and mounting bolts)

Belt Width		Ordering Number	Item Code	Wt. Lbs.
in.	mm			
24	600	MHCP-BCK24	75953	33.0
30	750	MHCP-BCK30	75954	44.0
36	900	MHCP-BCK36	75955	55.0
42	1050	MHCP-BCK42	75956	66.0
48	1200	MHCP-BCK48	75957	77.0
54	1350	MHCP-BCK54	75958	88.0
60	1500	MHCP-BCK60	75959	99.0
72	1800	MHCP-BCK72	75960	121.0
84	2100	MHCP-BCK84	76810	141.2
96	2400	MHCP-BCK96	78957	161.4

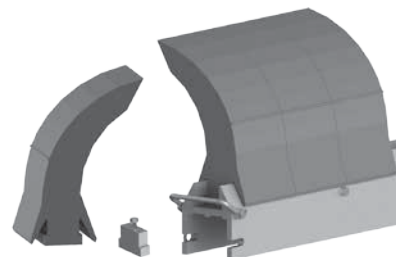

NOTE: For easy blade changeout, remove cartridge with worn blades and replace with new blade cartridge kit. New blades can then be installed in the old cartridge for the next changeout.

Lead time: 1 working day

Section 10 – Other Flexco Conveyor Products

Flexco provides many conveyor products that help your conveyors to run more efficiently and safely. These components solve typical conveyor problems and improve productivity. Here is a quick overview on just a few of them:

EZP1 Precleaner



- Patented ConShear™ blade renews its cleaning edge as it wears
- Visual Tension Check™ for optimal blade tensioning and simple retensioning
- Quick and easy one-pin blade replacement Material Path Option™ for optimal cleaning and reduced maintenance

EZS2 Secondary Cleaner



- Long-wearing tungsten carbide blades for superior cleaning efficiency
- Patented FormFlex™ cushions independently tension each blade to the belt for consistent, constant cleaning power
- Easy to install, simple to service
- Works with Flexco mechanical belt splices

Flexco Specialty Belt Cleaners



- “Limited space” cleaners for tight conveyor applications
- High Temp cleaners for severe, high heat applications
- A rubber fingered cleaner for chevron and raised rib belts
- Multiple cleaner styles in stainless steel for corrosive applications

DRX Impact Beds



- Exclusive Velocity Reduction Technology™ to better protect the belt
- Slide-Out Service™ gives direct access to all impact bars for change-out
- Impact bar supports for longer bar life
- 4 models to custom fit to the application

PT Max™ Belt Trainer



- Patented “pivot & tilt” design for superior training action
- Dual sensor rollers on each side to minimize belt damage
- Pivot point guaranteed not to freeze or seize up
- Available for topside and return side belts

Belt Plows



- A belt cleaner for the tail pulley
- Exclusive blade design quickly spirals debris off the belt
- Economical and easy to service
- Available in vee or diagonal models

The Flexco Vision

To become the leader in maximising
belt conveyor productivity for our customers worldwide
through superior service and innovation.



2525 Wisconsin Avenue • Downers Grove, IL 60515-4200 • USA
Tel: (630) 971-0150 • Fax: (630) 971-1180 • E-mail: info@flexco.com

Visit www.flexco.com for other Flexco locations and products.

©2016 Flexible Steel Lacing Company. 10/25/16. For Reorder: X2550

