

Maximum Cleaning for the Harshes Applications

The MHP Heavy-Duty Precleaner battles the worst environments with the most abrasion-resistant polyurethane blade Flexco offers. Features multiple material path options and extended pole lengths to ensure it fits the application perfectly. The enormous blade provides an extended life so this heavy-duty cleaner can get the job done.

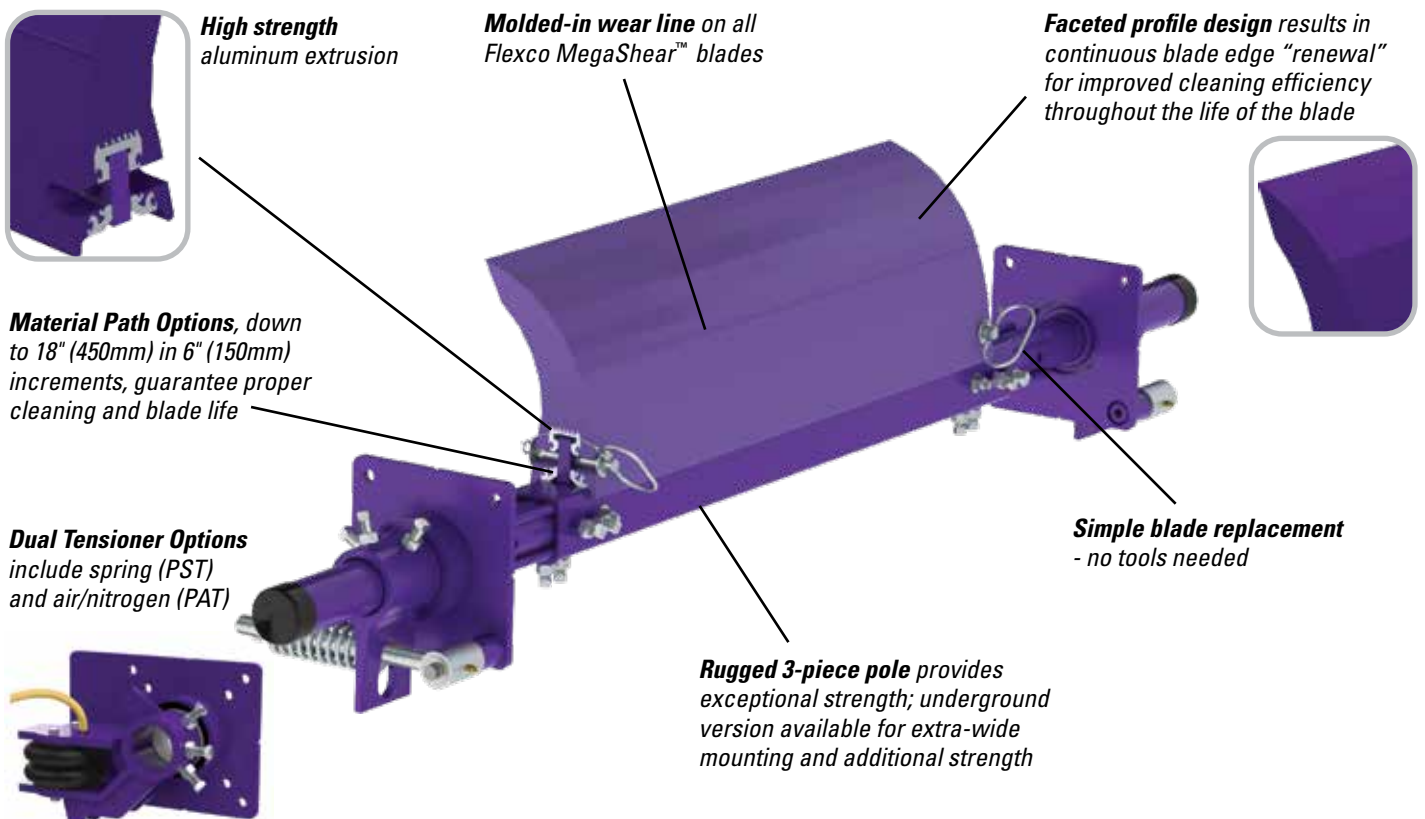

Features and Benefits

- **Versatile.** Pole length is belt width plus 54" (1350mm) to fit varying conveyor or chute wall widths. Pole extenders are available for extended length requirements.
- **Works with Flexco and other mechanical splices.** The spring tensioner quickly moves the blade away from the belt when a splice passes. The polyurethane blade easily glides over the splice without damage and with minimal cleaning disruption.
- **Made for mining conveyors.** Made from heavy-duty steel with corrosion-resistant powder coating, the MHP is available for belt widths from 24" to 120" (600 to 3000mm). Special sizes are available upon request.
- **Complete cleaning system.** When teamed with our MHS Secondary Cleaner, it makes up a system that delivers maximum cleaning power. If extra water is present, the MDWS DryWipe can be added.

MHP Heavy-Duty Precleaner

Specifications and Guidelines

- **Maximum Belt Speed**
1500 FPM (7.5 m/s)
- **Temperature Rating**
-30°F to 180°F (-35°C to 82°C)
- **Pulley Diameter**
20" (500 mm) min, 84" (2100mm) max
- **Blade Height**
12.25" (306 mm)
- **Usable Blade Wear Length**
8" (200 mm)
- **Blade Material**
Polyurethane (proprietary blend for abrasion resistance and long wear)
- **Available for Belt Widths**
24" to 120" (600 to 3000mm)
- **CEMA Cleaner Rating**
Class 5
- **Horizontal Clearance Required**
8" (200mm)
- **Vertical Clearance Required**
19.5" (488mm)

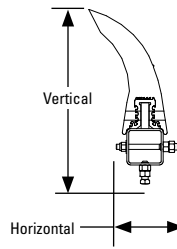

- **Pole Length**
Cleaner size + 54" (1350mm)
- **Maximum Conveyor Span**
Cleaner size + 42" (1050mm)

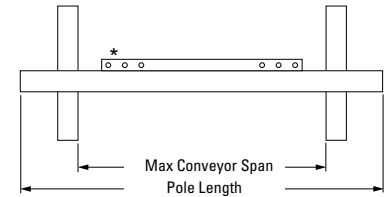

Ordering Information

MHP Precleaner - Belt Width Minus 6" (150mm)							
Belt Width		Blade Width		MHP with PST Tens		MHP with PAT Tens	
in.	mm	in.	mm	Ordering Number	Item Code	Ordering Number	Item Code
24	600	18	450	MHP-624	77703	MHP-624P	78599
30	750	24	600	MHP-630	77704	MHP-630P	78600
36	900	30	750	MHP-636	77705	MHP-636P	78601
42	1050	36	900	MHP-642	77706	MHP-642P	78602
48	1200	42	1050	MHP-648	77707	MHP-648P	78603
54	1350	48	1200	MHP-654	77708	MHP-654P	78604
60	1500	54	1350	MHP-660	77709	MHP-660P	78605
72	1800	66	1650	MHP-672	77710	MHP-672P	78606
84	2100	78	1950	MHP-684	77711	MHP-684P	78607
96	2400	90	2250	MHP-696	77712	MHP-696P	78608
108	2700	102	2550	MHP-6108	90151	MHP-6108P	90159
120	3000	114	2850	MHP-6120	90152	MHP-6120P	90160

MHP Precleaner - Belt Width Minus 12" (300mm)							
in.	mm	in.	mm	Ordering Number	Item Code	Ordering Number	Item Code
30	750	18	450	MHP-1230	77713	MHP-1230P	78609
36	900	24	600	MHP-1236	77714	MHP-1236P	78610
42	1050	30	750	MHP-1242	77715	MHP-1242P	78611
48	1200	36	900	MHP-1248	77716	MHP-1248P	78612
54	1350	42	1050	MHP-1254	77717	MHP-1254P	78613
60	1500	48	1200	MHP-1260	77718	MHP-1260P	78614
72	1800	60	1500	MHP-1272	77719	MHP-1272P	78615
84	2100	72	1800	MHP-1284	77720	MHP-1284P	78616
96	2400	84	2100	MHP-1296	77721	MHP-1296P	78617
108	2700	96	2400	MHP-12108	90153	MHP-12108P	90161
120	3000	108	2700	MHP-12120	90154	MHP-12120P	90162

Lead time: 1 working day

MHP Precleaner - Belt Width Minus 18" (450mm)							
Belt Width		Blade Width		MHP with PST Tens		MHP with PAT Tens	
in.	mm	in.	mm	Ordering Number	Item Code	Ordering Number	Item Code
36	900	18	450	MHP-1836	78591	MHP-1836P	78618
42	1050	24	600	MHP-1842	78592	MHP-1842P	78619
48	1200	30	750	MHP-1848	78593	MHP-1848P	78620
54	1350	36	900	MHP-1854	78594	MHP-1854P	78621
60	1500	42	1050	MHP-1860	78595	MHP-1860P	78622
72	1800	54	1350	MHP-1872	78596	MHP-1872P	78623
84	2100	66	1650	MHP-1884	78597	MHP-1884P	78624
96	2400	78	1950	MHP-1896	78598	MHP-1896P	78625
108	2700	90	2250	MHP-18108	90155	MHP-18108P	90163
120	3000	102	2550	MHP-18120	90156	MHP-18120P	90164

MHP Precleaner - Belt Width Minus 24" (600mm)							
in.	mm	in.	mm	Ordering Number	Item Code	Ordering Number	Item Code
42	1050	18	450	MHP-2442	78669	MHP-2442P	78676
48	1200	24	600	MHP-2448	78670	MHP-2448P	78677
54	1350	30	750	MHP-2454	78671	MHP-2454P	78678
60	1500	36	900	MHP-2460	78672	MHP-2460P	78679
72	1800	48	1200	MHP-2472	78673	MHP-2472P	78680
84	2100	60	1500	MHP-2484	78674	MHP-2484P	78681
96	2400	72	1800	MHP-2496	78675	MHP-2496P	78682
108	2700	84	2100	MHP-24108	90157	MHP-24108P	90165
120	3000	96	2400	MHP-24120	90158	MHP-24120P	90166

Lead time: 1 working day

MegaShear™ Replacement Blades											
Blade Width		Ordering Number	Item Code	Blade Width		Ordering Number	Item Code	Blade Width		Ordering Number	Item Code
in.	mm			in.	mm			in.	mm		
18	450	MRB18	77531	54	1350	MRB54	77537	90	2250	MRB90	77543
24	600	MRB24	77532	60	1500	MRB60	77538	96	2400	MRB96	77544
30	750	MRB30	77533	66	1650	MRB66	77539	102	2550	MRB102	77545
36	900	MRB36	77534	72	1800	MRB72	77540	108	2700	MRB108	77546
42	1050	MRB42	77535	78	1950	MRB78	77541	114	2850	MRB114	77547
48	1200	MRB48	77536	84	2100	MRB84	77542				

Authorized Distributor:



2525 Wisconsin Avenue • Downers Grove, IL 60515-4200 • USA
Tel: (630) 971-0150 • Fax: (630) 971-1180 • E-mail: info@flexco.com

Visit www.flexco.com for other Flexco locations and products.

©2021 Flexible Steel Lacing Company. 09/30/21. For reorder: X2512

