

# MDWS Secondary Cleaner

---

## Installation, Operation and Maintenance Manual

---

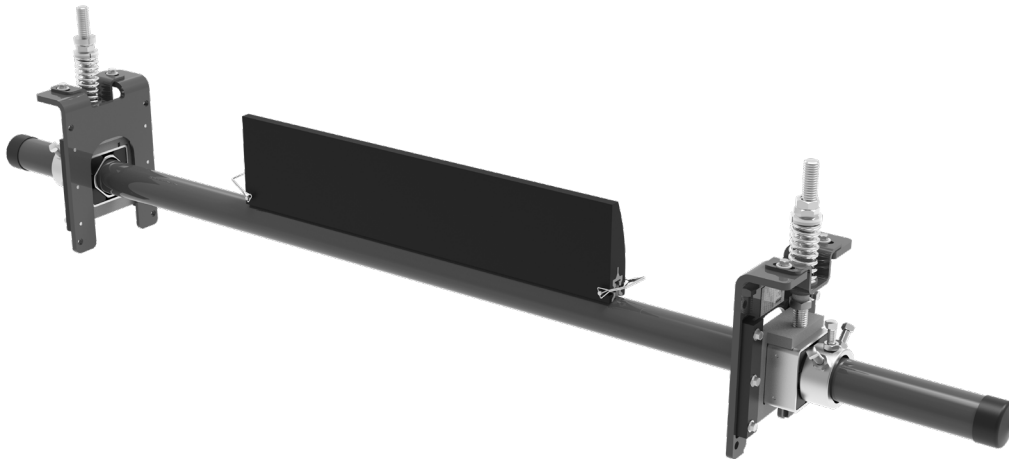

# MDWS DryWipe Secondary Cleaner

---

Serial Number:	_____
Purchase Date:	_____
Purchased From:	_____
Installation Date:	_____

Serial number information can be found on the Serial Number Label included in the Information Packet found in the cleaner carton.

This information will be helpful for any future inquiries or questions about belt cleaner replacement parts, specifications or troubleshooting.

# Table of Contents

---

<b>Section 1 - Important Information .....</b>	<b>4</b>
1.1 General Introduction .....	4
1.2 User Benefits .....	4
1.3 Service Option .....	4
<b>Section 2 - Safety Considerations and Precautions .....</b>	<b>5</b>
2.1 Stationary Conveyors.....	5
2.2 Operating Conveyors.....	5
<b>Section 3 - Pre-Installation Checks and Options.....</b>	<b>6</b>
3.1 Checklist .....	6
3.2 Optional Mounting Kits .....	7
<b>Section 4 - Installation Instructions.....</b>	<b>8</b>
4.1 MDWS - SST XD Tensioner .....	8
4.2 MDWS - SST XD Push-up Tensioning .....	10
4.3 MDWS - SAT XD Tensioner.....	11
4.4 MDWS - SAT XD Push-up Tensioning.....	13
<b>Section 5 - Pre-Operation Checklist and Testing.....</b>	<b>14</b>
5.1 Pre-Op Checklist .....	14
5.2 Test Run the Conveyor .....	14
<b>Section 6 - Maintenance.....</b>	<b>15</b>
6.1 New Installation Inspection .....	15
6.2 Routine Visual Inspection.....	15
6.3 Routine Physical Inspection .....	15
6.4 Blade Replacement Instructions.....	16
6.5 Maintenance Log.....	18
6.6 Cleaner Maintenance Checklist.....	19
<b>Section 7 - Troubleshooting .....</b>	<b>20</b>
<b>Section 8 - Specs and CAD Drawing .....</b>	<b>21</b>
8.1 Specs and Guidelines .....	21
8.2 CAD Drawing - MDWS - SST XD.....	22
8.3 CAD Drawing - MDWS - SAT XD .....	23
<b>Section 9 - Replacement Parts .....</b>	<b>24</b>
9.1 Replacement Parts List .....	24
<b>Section 10 - Other Flexco Conveyor Products .....</b>	<b>25</b>

# Section 1 - Important Information

---

## 1.1 General Introduction

We at Flexco are very pleased that you have selected a Belt Cleaner for your conveyor system.

This manual will help you to understand the operation of this product and assist you in making it work up to its maximum efficiency over its lifetime of service.

It is essential for safe and efficient operation that the information and guidelines presented be properly understood and implemented. This manual will provide safety precautions, installation instructions, maintenance procedures and troubleshooting tips.

If, however, you have any questions or problems that are not covered, please contact your field representative or our Customer Service Department.

Visit [www.flexco.com](http://www.flexco.com) for other Flexco locations and products.

Please read this manual thoroughly and pass it on to any others who will be directly responsible for installation, operation and maintenance of this cleaner. While we have tried to make the installation and service tasks as easy and simple as possible, it does however require correct installation and regular inspections and adjustments to maintain top working condition.

## 1.2 User Benefits

Correct installation and regular maintenance will provide the following benefits for your operation:

- Reduced conveyor downtime
- Reduced man-hour labor
- Lower maintenance budget costs
- Increased service life for the belt cleaner and other conveyor components

## 1.3 Service Option

The MDWS DryWipe Secondary Cleaner is designed to be easily installed and serviced by your on-site personnel. However, if you would prefer complete turn-key factory service, please contact your local Flexco Field Representative.

# Section 2 - Safety Considerations and Precautions

---

Before installing and operating the MDWS DryWipe Secondary Cleaner, it is important to review and understand the following safety information.

There are set-up, maintenance and operational activities involving both stationary and operating conveyors. Each case has a safety protocol.

---

## 2.1 Stationary Conveyors

The following activities are performed on stationary conveyors:

- Installation
- Tension adjustments
- Blade replacement
- Cleaning
- Repairs

### **DANGER**

It is imperative that OSHA/MSHA Lockout/Tagout (LOTO) regulations, 9 CFR 1910.147, be followed before undertaking the preceding activities. Failure to use LOTO exposes workers to uncontrolled behavior of the belt cleaner caused by movement of the conveyor belt. Severe injury or death can result.

Before working:

- Lockout/Tagout the conveyor power source.
- Disengage any takeups.
- Clear the conveyor belt or clamp securely in place.

### **WARNING**

Use Personal Protective Equipment (PPE):

- Safety eyewear
- Hardhats
- Safety footwear

Close quarters, springs and heavy components create a worksite that compromises a worker's eyes, feet and skull. PPE must be worn to control the foreseeable hazards associated with conveyor belt cleaners. Serious injuries can be avoided.

---

## 2.2 Operating Conveyors

There are two routine tasks that must be performed while the conveyor is running:

- Inspection of the cleaning performance.
- Dynamic troubleshooting.

### **DANGER**

Every belt cleaner is an in-running nip hazard. Never touch or prod an operating cleaner. Cleaner hazards cause instantaneous amputation and entrapment.

### **WARNING**

Belt cleaners can become projectile hazards. Stay as far from the cleaner as practical and use safety eyewear and headgear. Missiles can inflict serious injury.

### **WARNING**

Never adjust anything on an operating cleaner. Unforseeable belt projections and tears can catch on cleaners and cause violent movements of the cleaner structure. Flailing hardware can cause serious injury or death.

## Section 3 - Pre-installation Checks and Options

---

### 3.1 Checklist

- Check that the cleaner size is correct for the beltline width.
- Check the belt cleaner carton and make sure all the parts are included.
- Review the “Tools Needed” list on the top of the installation instructions.
- Check the conveyor site:
  - Will the cleaner be installed on a chute?
  - Is the install on an open head pulley requiring mounting structure?  
(see 3.2 - Optional Installation Accessories)

# Section 3 - Pre-installation Checks and Options

## 3.2 Optional Mounting Kits

Versatile, adjustable brackets and plates that can be mounted on the conveyor structure so precleaners and secondary cleaners can be easily and quickly bolted into place. Pole extenders are also available for wide, non-standard conveyor structures.

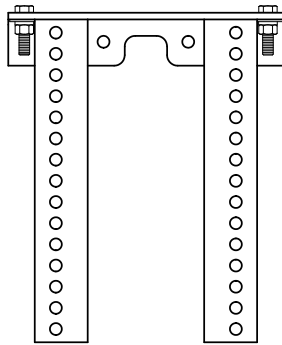

**SST Standard Mounting Bracket Kit (for SST XD Tensioner)**  
(Item Code: 76071)

- For most secondary cleaner installs.
- 13 x 15-1/2" (325 x 388mm)

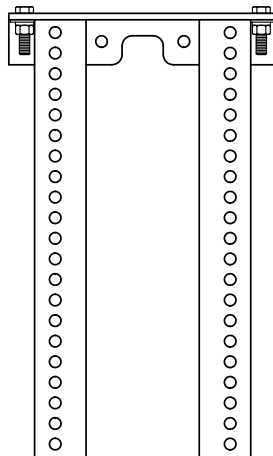

**SST Long Mounting Bracket Kit (for SST XD Tensioner)**  
(Item Code: 76072)

- For installations that require extra length legs.
- 13 x 21-1/2" (325 x 538mm)

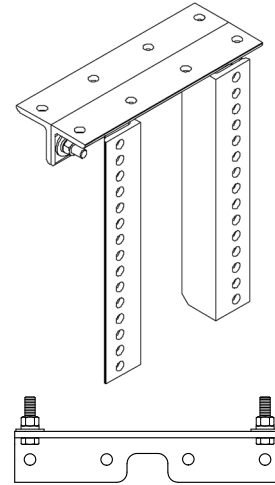

**SST Optional Top Angle Kit (for SST XD Tensioner)**  
(Item Code: 76073)

- Used with both standard and long mounting bracket kits for additional mounting options.
- 13" (325mm) Length

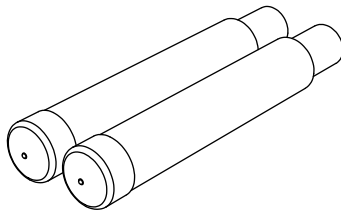

**Pole Extender Kit (incl. 2 pole extenders)**  
(Item Code: 76024)

- For cleaner sizes 72" (1800mm) and larger
- Provides 30" (750mm) of extended pole length

**Optional Mounting Kits (includes 2 brackets/bars)**

DESCRIPTION	ORDERING NUMBER	ITEM CODE	WT. LBS.
Standard Mounting Bracket Kit *	SSTSMB	76071	34.3
Long Mounting Bracket Kit *	SSTLMB	76072	43.5
Optional Top Angle Kit *	SSTOTA	76073	10.5
Pole Extender Kit	MAPEK	76024	21.9

\*Hardware Included  
Lead time: 1 working day

# Section 4 - Installation Instructions

## 4.1 MDWS - SST XD Tensioner

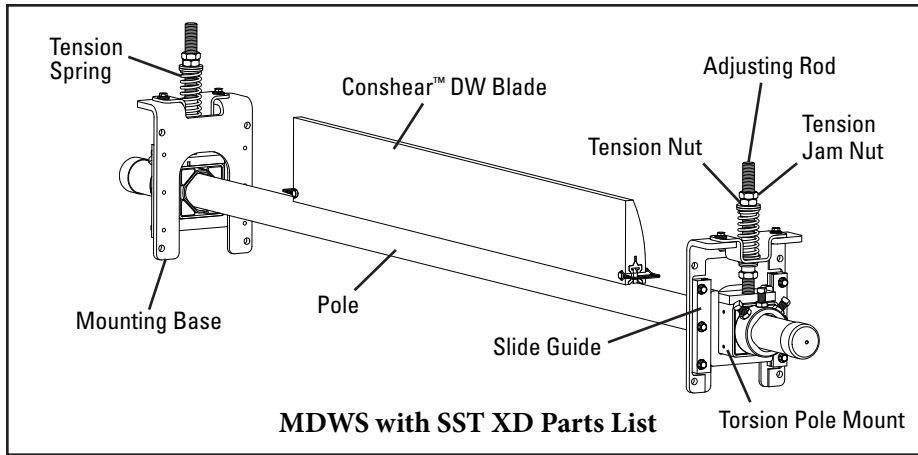

**PHYSICALLY LOCK OUT AND TAG THE CONVEYOR AT THE POWER SOURCE BEFORE YOU BEGIN CLEANER INSTALLATION.**

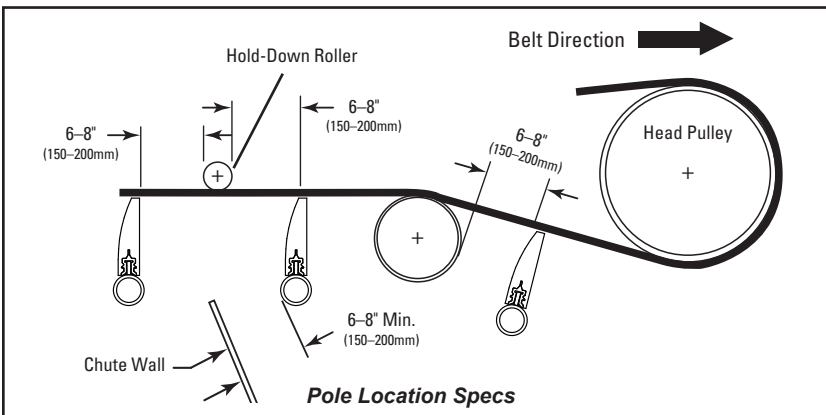

- 1. Install the spring tensioner mounting bases.** Clamp the mounting base into position so the top flange of the base is 1" (25mm) above the belt (Fig. 1). Bolt or weld the mounting base in place. Locate and install the mounting base on the opposite side.

**NOTE:** For chute mounting, a belt location line must be drawn on the chute wall so the mounting base can be positioned 1" (25mm) above the belt (Fig. 1a). Cut access holes as needed.

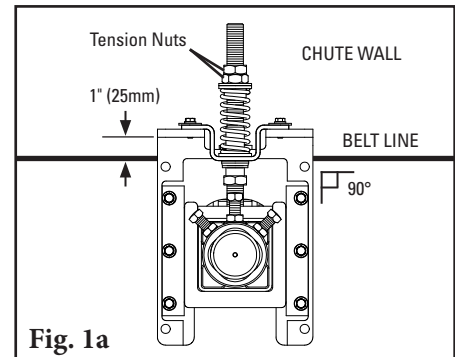
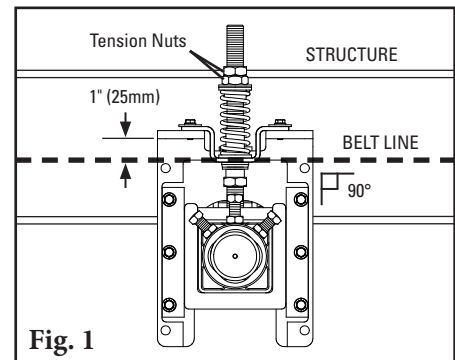



# Section 4 - Installation Instructions

## 4.1 MDWS - SST XD Tensioner

2. **Install the pole.** Slide the pole into one torsion pole mount as far as needed and locate the other end into the opposite mount (Fig. 2). If there is not enough space, remove one of the torsion pole mounts from the mounting base, slide the pole through the mounting base and reassemble (Fig. 2a).

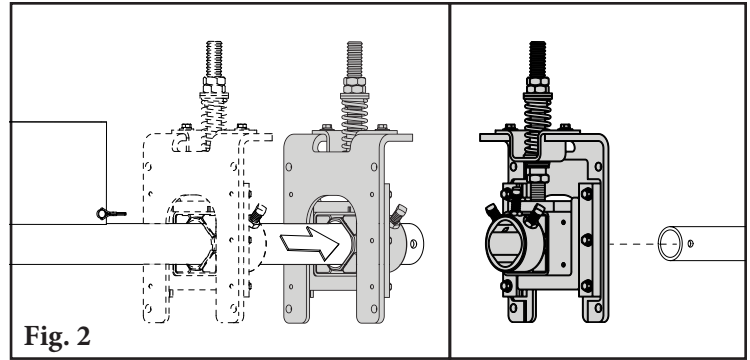

3. **Set the blade angle.** Center the pole/blade on the belt. Using the angle gauge provided, rotate the blade up to the belt to the preset angle.

Tighten the three locking bolts on each torsion pole mount to lock the pole in place. Best practice is to first tighten the middle bolt before tightening the outer bolts to ensure everything is secure (Fig. 3). There should be no blade-to-belt contact while locking the pole in the correct position. If contact occurs, lower the pole by turning the adjusting rod tension nuts and reset the angle.

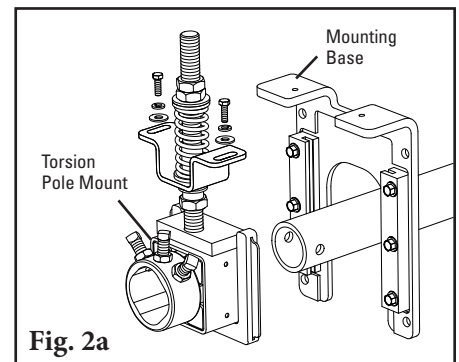

4. **Set the blade tension.** Loosen the top tension jam nuts on both sides. Turn the tension nuts until the correct spring compression is reached. Spring compression is determined by spring length. See the chart above for the correct spring length for your belt width.

5. **Set adjusting rod sleeve.** After setting the blade tension, screw the adjusting rod sleeve into the UHMW bushing until 1-1/2" (38mm) is showing (Fig. 4). Tighten the adjusting rod sleeve jam nut.

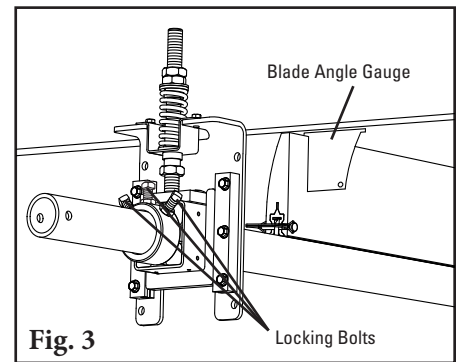

6. **Test run the cleaner and inspect the cleaning performance.** If vibration occurs or more cleaning efficiency is desired, increase the blade tension by making 1/8" (3mm) compression adjustments on the tension springs.

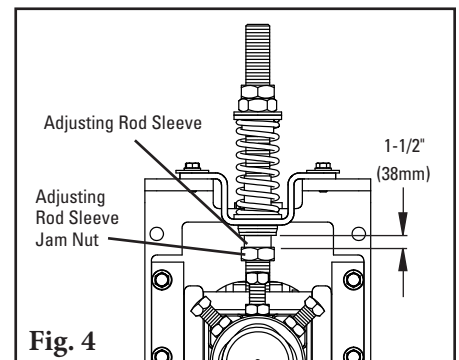

**SST XD Spring Length Chart**

Blade Width		White Springs		Silver Springs		Black Springs		Gold Springs	
in.	mm	in.	mm	in.	mm	in.	mm	in.	mm
18	450	3 3/8	86	4	102	N/A	N/A	N/A	N/A
24	600	3 1/8	79	3 7/8	98	N/A	N/A	N/A	N/A
30	750	2 7/8	73	3 3/4	95	N/A	N/A	N/A	N/A
36	900	N/A	N/A	3 3/4	95	3 7/8	98	N/A	N/A
42	1050	N/A	N/A	3 5/8	92	3 3/4	95	N/A	N/A
48	1200	N/A	N/A	3 1/2	89	3 5/8	92	N/A	N/A
54	1350	N/A	N/A	3 3/8	86	3 5/8	92	3 3/4	95
60	1500	N/A	N/A	3 1/4	83	3 1/2	89	3 3/4	95
72	1800	N/A	N/A	N/A	N/A	3 3/8	86	3 5/8	92
84	2100	N/A	N/A	N/A	N/A	3 1/8	79	3 1/2	89
96	2400	N/A	N/A	N/A	N/A	N/A	N/A	3 3/8	86
108	2700	N/A	N/A	N/A	N/A	N/A	N/A	3 1/2	89
120	3000	N/A	N/A	N/A	N/A	N/A	N/A	3 3/8	86

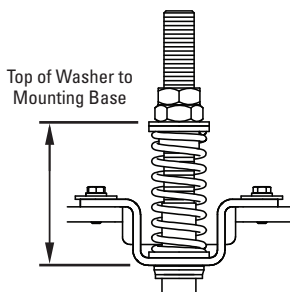

Shading indicates preferred spring option.

# Section 4 - Installation Instructions

## 4.2 MDWS - SST XD Push-Up Tensioning

- 1. Reconfigure the standard pull-up tensioner to the push-up style.** Remove the 3 tension nuts, the flat washer, 2 bushings, the spring, the sleeve and the hat bracket; reassemble (Fig. 1) with 2 tension nuts, the flat washer, 2 bushings, the spring and the hat bracket on the upper end of the adjusting rod. Add washer (from instruction packet) and 3rd tension nut to bottom of adjusting rod.
- 2. Install the tensioner mounting bases.** Mount the bases to the structure or chute so that the tops of the base legs are 1-1/4" (32mm) below the belt (Fig. 1).
- 3. Install the cleaner pole and set the blade angle.** Follow the installation steps from the cleaner instructions on Page 9.

**NOTE:** be sure the lock bolts on the torsion pole mount have been securely tightened to lock the pole in place before moving to Step 4.

- 4. Set the blade tension.** Remove the bottom tension nut and washer from the adjusting rod. Turn the two upper tension nuts until the spring is compressed to the length shown on the Spring Length Chart below. Tighten the two tension nuts together to prevent loosening.
- 5. Replace the sleeve.** Position the sleeve over the adjusting rod and turn it until it is in the middle of the bushing. Replace the bottom tension nut and tighten until it locks the sleeve in place (Fig. 2).

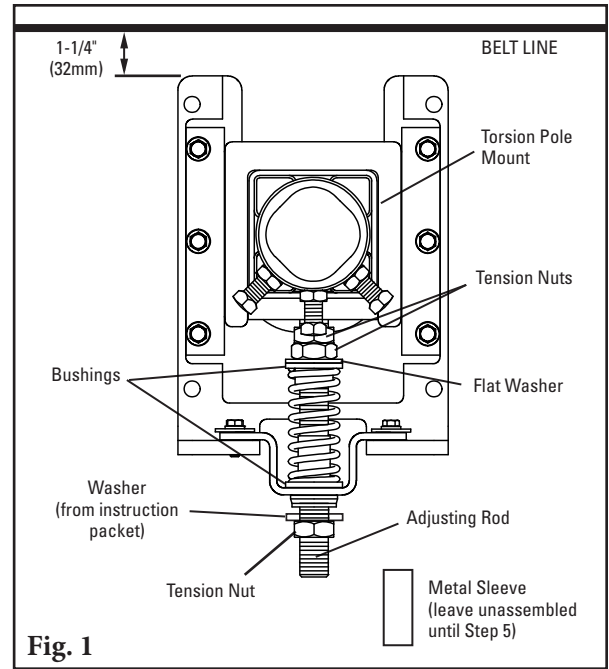

**Fig. 1**

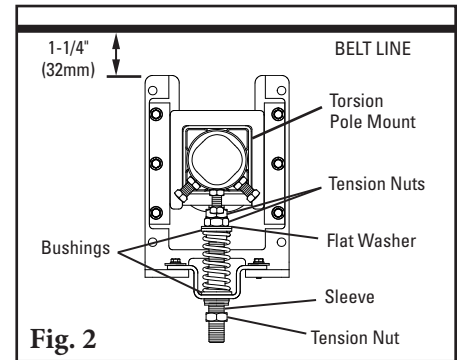

**Fig. 2**

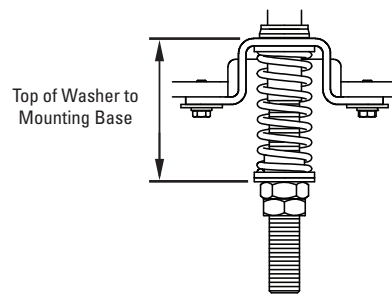

### SST XD Spring Length Chart

Blade Width		White Springs		Silver Springs		Black Springs		Gold Springs	
in.	mm	in.	mm	in.	mm	in.	mm	in.	mm
18	450	3 3/8	86	4	102	N/A	N/A	N/A	N/A
24	600	3 1/8	79	3 7/8	98	N/A	N/A	N/A	N/A
30	750	2 7/8	73	3 3/4	95	N/A	N/A	N/A	N/A
36	900	N/A	N/A	3 3/4	95	3 7/8	98	N/A	N/A
42	1050	N/A	N/A	3 5/8	92	3 3/4	95	N/A	N/A
48	1200	N/A	N/A	3 1/2	89	3 5/8	92	N/A	N/A
54	1350	N/A	N/A	3 3/8	86	3 5/8	92	3 3/4	95
60	1500	N/A	N/A	3 1/4	83	3 1/2	89	3 3/4	95
72	1800	N/A	N/A	N/A	N/A	3 3/8	86	3 5/8	92
84	2100	N/A	N/A	N/A	N/A	3 1/8	79	3 1/2	89
96	2400	N/A	N/A	N/A	N/A	N/A	N/A	3 3/8	86
108	2700	N/A	N/A	N/A	N/A	N/A	N/A	3 1/2	89
120	3000	N/A	N/A	N/A	N/A	N/A	N/A	3 3/8	86

Shading indicates preferred spring option.

# Section 4 - Installation Instructions

## 4.3 MDWS - SAT XD Tensioner

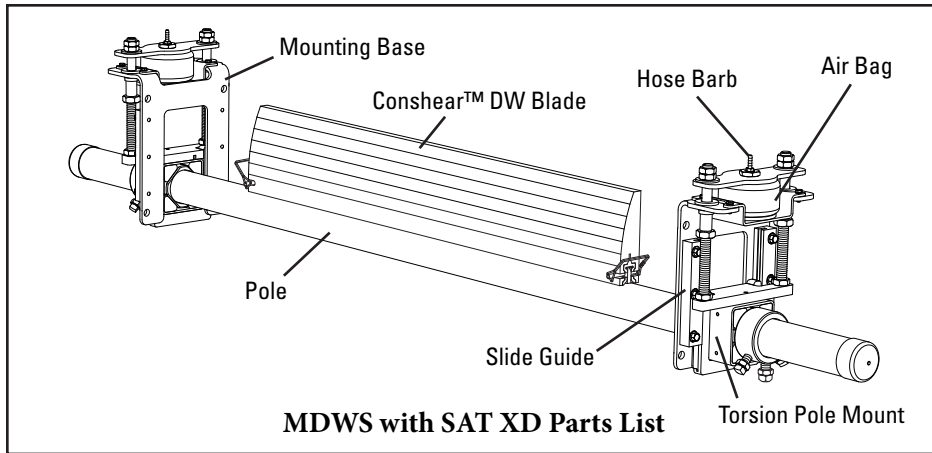

**PHYSICALLY LOCK OUT AND TAG THE CONVEYOR AT THE POWER SOURCE BEFORE YOU BEGIN CLEANER INSTALLATION.**

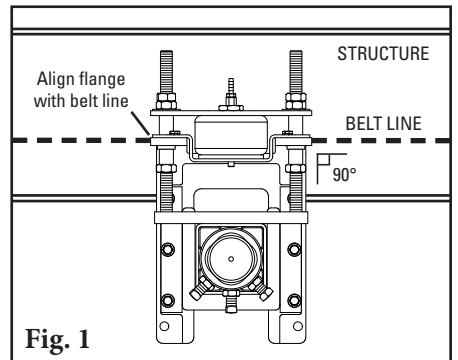
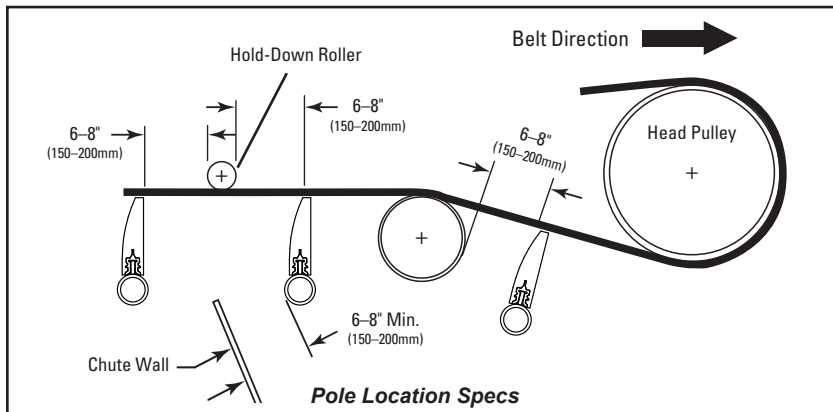

**Fig. 1**

- 1. Install the air/water tensioner mounting bases.** Clamp the mounting base into position so the top flange is even with the belt (Fig. 1). Bolt the mounting base in place. Locate and install the mounting base on the opposite side.

**NOTE:** For chute mounting, a belt location line must be drawn on the chute wall so the mounting base can be aligned with the belt (Fig. 1a). Cut access holes as needed.

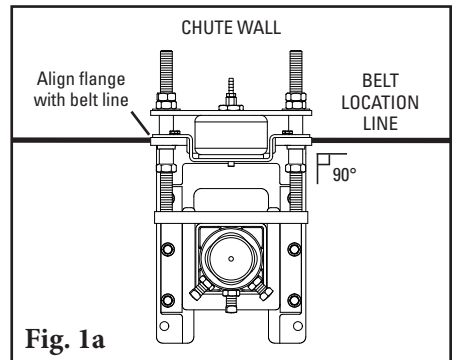

**Fig. 1a**

**NOTE:** If push-up tensioning is needed because of space restriction or obstruction, follow steps on Page 13 to reconfigure the tensioners.

# Section 4 - Installation Instructions

## 4.3 MDWS - SAT XD Tensioner

- Install the pole.** Slide the pole into one torsion pole mount as far as needed and locate the other end into the opposite mount (Fig. 2). If there is not enough space, remove one of the mounting bases, slide the pole through the torsion pole mount, and remount the base.
- Set the blade angle.** Center the pole/blade on the belt. Rotate the pole until the blade is perpendicular to the belt, using the blade setup gauge provided. Tighten the three locking bolts on each torsion pole mount to lock the pole in place. Best practice is to first tighten the middle bolt before tightening the outer bolts to ensure everything is secure (Fig. 3). There should be no blade-to-belt contact while locking the pole in the correct position. If contact occurs, double check the dimension from Step 1.
- Set adjusting rod sleeve.** After setting the blade tension, screw the adjusting rod sleeve into the UHMW bushing until 1-1/2" (38mm) is showing (Fig. 4). Tighten the adjusting rod sleeve jam nut.
- Connect the supply lines and set tension pressure.** With the parts supplied, attach a line to each air bag and run the lines to the outlet side of the control box (Fig. 5).

**NOTE:** Be sure lines are safely away from the belt. Connect the line from the inlet side of the box to the site's supply or air tank. Test the connections for leaks and set the pressure per the chart below. Pressure may be reduced to suit application.

- Test run the cleaner and inspect the cleaning performance.** If vibration occurs, increase tip layback by a small amount (approx. 3 degrees).

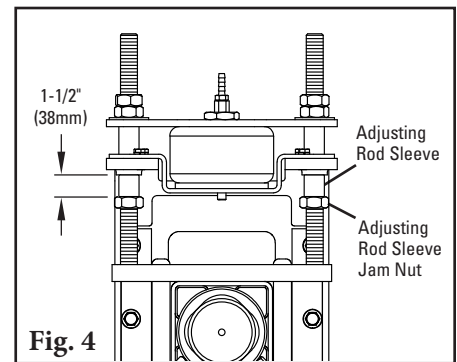
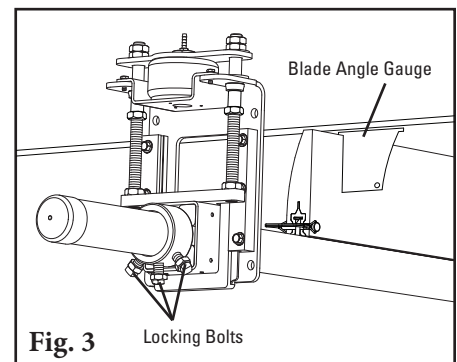
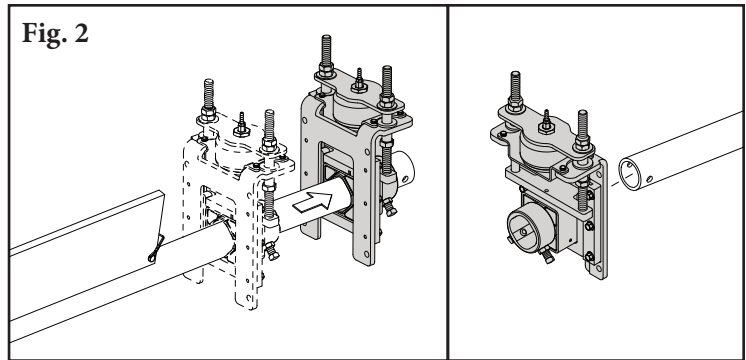

**SAT XD Pressure Chart**

Blade Width		Pressure	
in.	mm	psi	kPa
18	450	15	103
24	600	19	131
30	750	23	159
36	900	27	186
42	1050	31	214
48	1200	35	241
54	1350	39	269
60	1500	43	296
72	1800	51	352
84	2100	59	407
96	2400	67	462

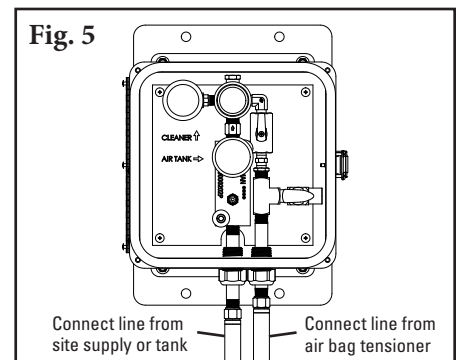

# Section 4 - Installation Instructions

## 4.4 MDWS - SAT XD Push-Up Tensioning

1. **Disassemble guide kit.** Remove nuts and washers from both sides of tensioner (Fig. 1).
2. **Disassemble upper mounting plate and air bag.** Remove and save bushing nut. Remove and discard upper mounting plate. Remove (unscrew) and save air bag, threaded insert and support plate (Fig. 2).  
**Optional:** Remove guide bushings and adjusting rod sleeves. It will not affect the tensioner if left in place.
3. **Remove and save top hat bracket and its hardware** (Fig. 3).
4. **Flip over PAT mounting bracket assembly.** The two flanges are now at the bottom.

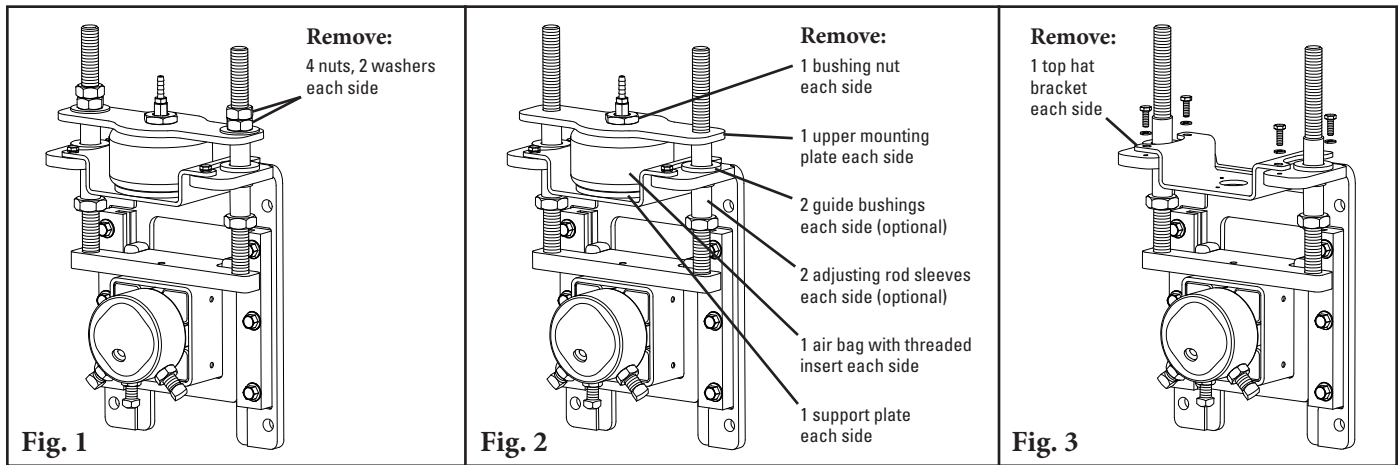

5. **Reassemble the SAT XD Tensioner.** Remove three screws from air bag support plate (Fig. 4). Turn the threaded insert into the support plate. Also turn part of the threaded insert into the hole on pole mount. (Fig. 4a). Ensure 1/4" (6mm) of threaded insert is still exposed, then turn the air bag onto the threaded insert and tighten (Fig. 5).
6. **Reassemble top hat bracket.** Ensure bracket is resting on flanges of mounting bracket. Screw sleeves into bushings and tighten locknuts (Fig. 6).
7. **Slide pole mount/threaded rods/air bag assembly down** with hose barb through hole in top hat bracket and reinstall bushing nut (Fig. 6).
8. **Complete installation** by following the steps on Page 12.

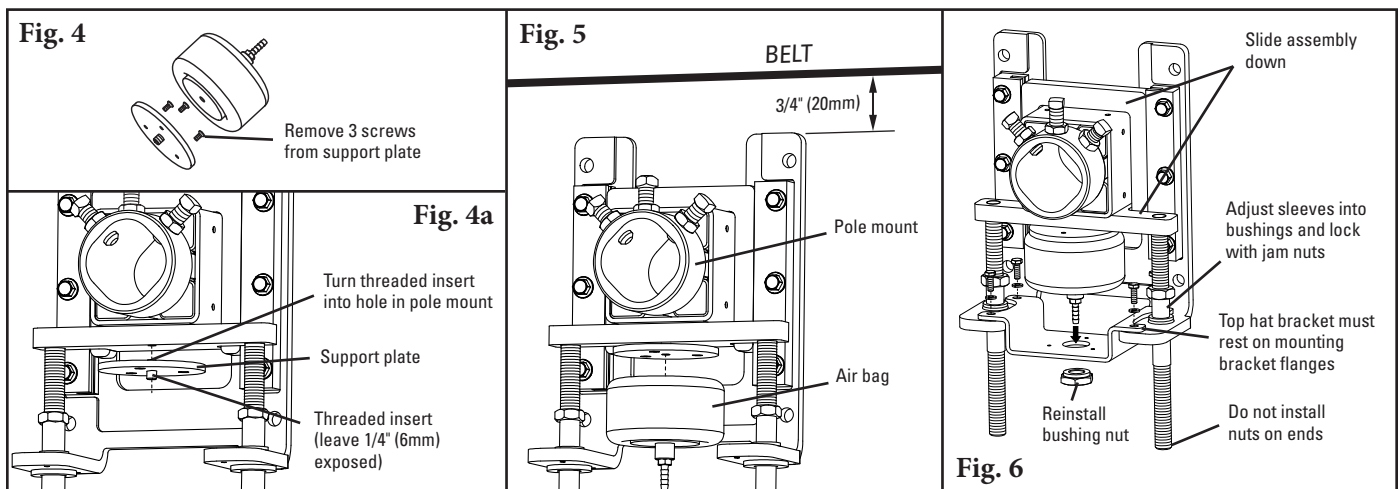

## Section 5 - Pre-Operation Checklist and Testing

---

### 5.1 Pre-Op Checklist

- Recheck that all fasteners are tightened properly.
- Add pole caps.
- Apply all supplied labels to the cleaner.
- Check the blade location on the belt.
- Be sure that all installation materials and tools have been removed from the belt and the conveyor area.

### 5.2 Test Run the Conveyor

- Run the conveyor for at least 15 minutes and inspect the cleaning performance.
- Check the tensioner spring for recommended length (proper tensioning).
- Make adjustments as necessary.

**NOTE:** Observing the cleaner when it is running and performing properly will help to detect problems or when adjustments are needed later.

## Section 6 - Maintenance

---

Flexco belt cleaners are designed to operate with minimum maintenance. However, to maintain superior performance some service is required. When the cleaner is installed a regular maintenance program should be set up. This program will ensure that the cleaner operates at optimal efficiency and problems can be identified and fixed before the cleaner stops working.

All safety procedures for inspection of equipment (stationary or operating) must be observed. The MDWS DryWipe Belt Cleaner operates at the discharge end of the conveyor and is in direct contact with the moving belt. Only visual observations can be made while the belt is running. Service tasks can be done only with the conveyor stopped and by observing the correct lockout/tagout procedures.

### 6.1 New Installation Inspection

After the new cleaner has run for a few days a visual inspection should be made to ensure the cleaner is performing properly. Make adjustments as needed.

### 6.2 Routine Visual Inspection (every 2-4 weeks)

A visual inspection of the cleaner and belt should look for:

- If spring length is the correct length for optimal tensioning.
- If spring gap is correct for optimal tensioning.
- If belt looks clean or if there are areas that are dirty.
- If blade is worn out and needs to be replaced.
- If there is damage to the blade or other cleaner components.
- If fugitive material is built up on cleaner or in the transfer area.
- If there is cover damage to the belt.
- If there is vibration or bouncing of the cleaner on the belt.
- If a snub pulley is used, a check should be made for material buildup on the pulley.
- Significant signs of carryback.

If any of the above conditions exist, a determination should be made on when the conveyor can be stopped for cleaner maintenance.

### 6.3 Routine Physical Inspection (every 6-8 weeks)

When the conveyor is not in operation and properly locked and tagged out, a physical inspection of the cleaner to perform the following tasks:

- Clean material buildup off of the cleaner blade and pole.
- Closely inspect the blade for wear and any damage. Replace if needed.
- Ensure full blade to belt contact.
- Inspect the cleaner pole for damage.
- Inspect all fasteners for tightness and wear. Tighten or replace as needed.
- Replace any worn or damaged components.
- Check the tension of the cleaner blade to the belt. Adjust the tension if necessary using the chart on the cleaner.
- When maintenance tasks are completed, test run the conveyor to ensure the cleaner is performing properly.

## Section 6 – Maintenance

### 6.4 Blade Replacement Instructions

**PHYSICALLY LOCK OUT AND TAG THE CONVEYOR AT THE POWER SOURCE BEFORE YOU BEGIN CLEANER INSTALLATION.**

#### 1. Release the blade tension and remove worn blade tips.

- a. Loosen the tension nuts on both tensioners to the top of the adjusting rod (Fig. 1). If using air tensioner, release air pressure. If accessible, remove blade pins from the blade and remove the worn blade (Fig. 1c).
- b. Loosen the pole lock bolts on both ends (Fig. 1a) and allow the blade to rotate downward. If accessible, remove the blade pins from the blade and remove the blade (Fig. 1c).
- c. Make a mark on the structure or mounting bracket above one SST XD/SAT XD tensioner. Remove the SST XD/SAT XD mounting bolts, nuts, and washers from one tensioner (Fig. 1b) then remove the tensioner and pole.
- d. Remove the blade pins from the blade and remove blade (Fig. 1c).
- e. Insert new blade and blade pins.

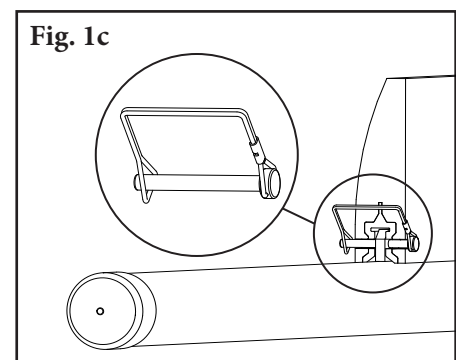
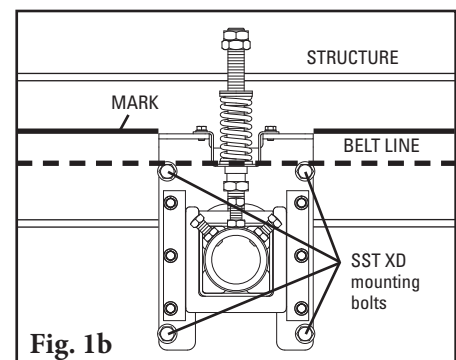
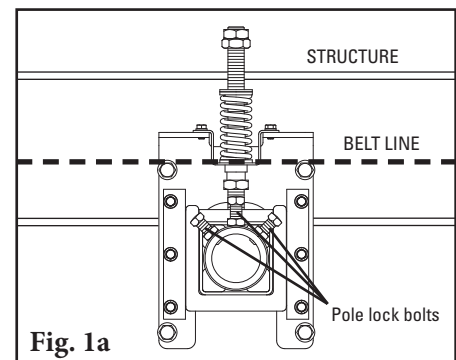
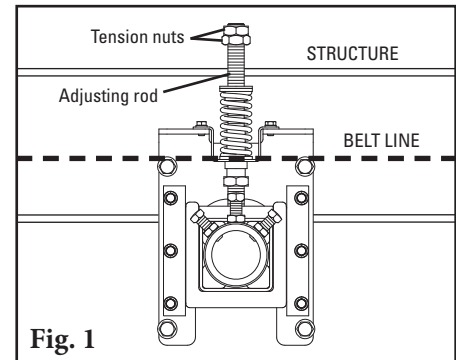



# Section 6 – Maintenance

## 6.4 Blade Replacement Instructions

2. **Reinstall the pole and tensioner.**  
 (If not removed, skip to Step 3.)  
 Slide the pole into the mounted tensioner (Fig. 2). Remount the SST XD/SAT XD tensioner using the marks made in Step 1c (Fig. 2).

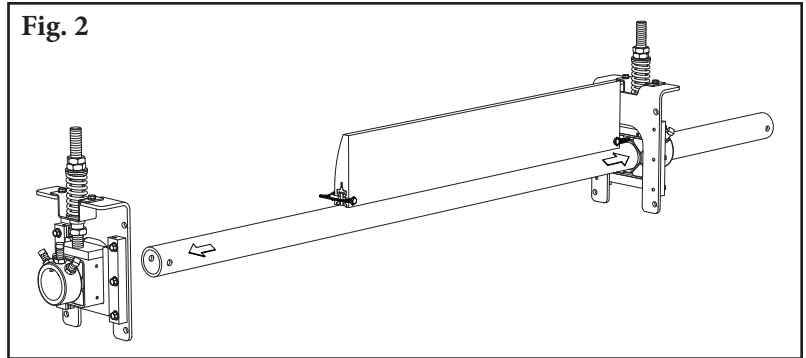

3. **Set the blade angle.** (If the pole was not turned down or removed, skip to Step 4.)  
 Center the pole/blades on the belt. Using the tip gauge, align the blade so the top of the gauge is aligned with the belt (Fig. 3). Tighten the three locking bolts on each tensioner to lock the pole in place. Best practice is to first tighten the middle bolt before tightening the outer bolts to ensure everything is secure (Fig. 3).

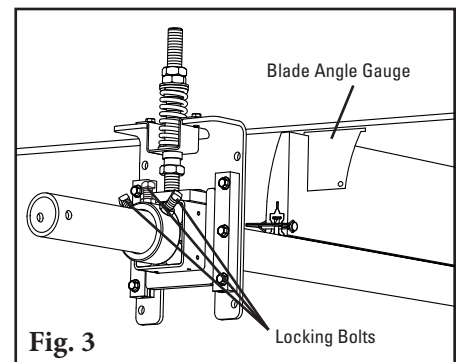

4. **Set the blade tension.** Loosen the top tension jam nuts on both sides. Turn the lower tension jam nuts on both sides. Turn the lower tension nut until the correct spring compression is reached (Fig. 4). Tighten the top tension jam nut to lock in place. See chart below for the correct spring length for your belt width. If using air pressure, reset the control box to the specified pressure in chart below.

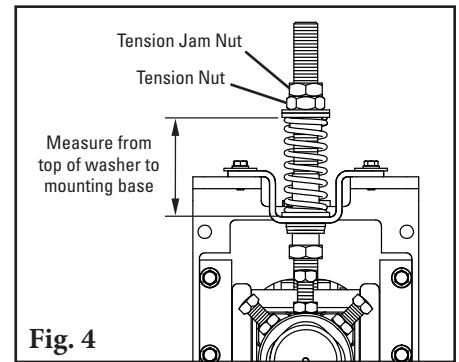

5. **Test run the conveyor and inspect the cleaning performance.**  
 If vibration occurs or more cleaning efficiency is desired, increase the blade tension by making 1/8" (3mm) compression adjustments on the tension springs.

**SST XD Spring Length Chart**

Blade Width		White Springs		Silver Springs		Black Springs		Gold Springs	
in.	mm	in.	mm	in.	mm	in.	mm	in.	mm
18	450	3 3/8	86	4	102	N/A	N/A	N/A	N/A
24	600	3 1/8	79	3 7/8	98	N/A	N/A	N/A	N/A
30	750	2 7/8	73	3 3/4	95	N/A	N/A	N/A	N/A
36	900	N/A	N/A	3 3/4	95	3 7/8	98	N/A	N/A
42	1050	N/A	N/A	3 5/8	92	3 3/4	95	N/A	N/A
48	1200	N/A	N/A	3 1/2	89	3 5/8	92	N/A	N/A
54	1350	N/A	N/A	3 3/8	86	3 5/8	92	3 3/4	95
60	1500	N/A	N/A	3 1/4	83	3 1/2	89	3 3/4	95
72	1800	N/A	N/A	N/A	N/A	3 3/8	86	3 5/8	92
84	2100	N/A	N/A	N/A	N/A	3 1/8	79	3 1/2	89
96	2400	N/A	N/A	N/A	N/A	N/A	N/A	3 3/8	86
108	2700	N/A	N/A	N/A	N/A	N/A	N/A	3 1/2	89
120	3000	N/A	N/A	N/A	N/A	N/A	N/A	3 3/8	86

Shading indicates preferred spring option.

**SAT XD Pressure Chart**

Blade Width		Pressure	
in.	mm	psi	kPa
18	450	15	103
24	600	19	131
30	750	23	159
36	900	27	186
42	1050	31	214
48	1200	35	241
54	1350	39	269
60	1500	43	296
72	1800	51	352
84	2100	59	407
96	2400	67	462

# Section 6 - Maintenance

---

## 6.5 Maintenance Log

Conveyor Name/No. \_\_\_\_\_

Date: \_\_\_\_\_ Work done by: \_\_\_\_\_ Service Quote #: \_\_\_\_\_

Activity: \_\_\_\_\_

---

Date: \_\_\_\_\_ Work done by: \_\_\_\_\_ Service Quote #: \_\_\_\_\_

Activity: \_\_\_\_\_

---

Date: \_\_\_\_\_ Work done by: \_\_\_\_\_ Service Quote #: \_\_\_\_\_

Activity: \_\_\_\_\_

---

Date: \_\_\_\_\_ Work done by: \_\_\_\_\_ Service Quote #: \_\_\_\_\_

Activity: \_\_\_\_\_

---

Date: \_\_\_\_\_ Work done by: \_\_\_\_\_ Service Quote #: \_\_\_\_\_

Activity: \_\_\_\_\_

---

Date: \_\_\_\_\_ Work done by: \_\_\_\_\_ Service Quote #: \_\_\_\_\_

Activity: \_\_\_\_\_

---

Date: \_\_\_\_\_ Work done by: \_\_\_\_\_ Service Quote #: \_\_\_\_\_

Activity: \_\_\_\_\_

---

Date: \_\_\_\_\_ Work done by: \_\_\_\_\_ Service Quote #: \_\_\_\_\_

Activity: \_\_\_\_\_

# Section 6 - Maintenance

## 6.6 Cleaner Maintenance Checklist

Site: \_\_\_\_\_ Inspected by: \_\_\_\_\_ Date: \_\_\_\_\_

Belt Cleaner: \_\_\_\_\_ Serial Number: \_\_\_\_\_

### Beltline Information:

Beltline Number: \_\_\_\_\_ Belt Condition: \_\_\_\_\_

Belt Width:  18" (450mm)  24" (600mm)  30" (750mm)  36" (900mm)  42" (1050mm)  48" (1200mm)  54" (1350mm)  60" (1500mm)  72" (1800mm)  84" (2100mm)  96" (2400mm)

Belt Speed: \_\_\_\_\_ fpm Belt Thickness: \_\_\_\_\_

Belt Splice: \_\_\_\_\_ Condition of Splice: \_\_\_\_\_ Number of Splices: \_\_\_\_\_  Skived  Unskived  
\*It is recommended that mechanical fasteners on the belt be skived.

Material conveyed: \_\_\_\_\_

Days per week run: \_\_\_\_\_ Hours per day run: \_\_\_\_\_

### Blade Life:

Date blade installed: \_\_\_\_\_ Date blade inspected: \_\_\_\_\_ Estimated blade life: \_\_\_\_\_

Is blade making complete contact with belt?  Yes  No

Blade wear: Left \_\_\_\_\_ Middle \_\_\_\_\_ Right \_\_\_\_\_

Blade condition:  Good  Grooved  Smiled  Not contacting belt  Damaged

Measurement of spring: Required \_\_\_\_\_ Currently \_\_\_\_\_

For SAT XD Tensioner only: Air/Nitrogen Pressure Required \_\_\_\_\_ Currently \_\_\_\_\_  
Inspect SAT XD bags and lines

Was Cleaner Adjusted:  Yes  No

Pole Condition:  Good  Bent  Worn

Lagging:  Side Lag  Ceramic  Rubber  Other  None

Condition of lagging:  Good  Bad  Other \_\_\_\_\_

Cleaner's Overall Performance: \_\_\_\_\_ (Rate the following 1 - 5, 1= very poor - 5 = very good)

Appearance: \_\_\_\_\_ Comments: \_\_\_\_\_

Location: \_\_\_\_\_ Comments: \_\_\_\_\_

Maintenance: \_\_\_\_\_ Comments: \_\_\_\_\_

Performance: \_\_\_\_\_ Comments: \_\_\_\_\_

Other comments: \_\_\_\_\_



## Section 7 - Troubleshooting

Problem	Possible Cause	Possible Solutions
Vibration.	Cleaner secure bolts not set.	Ensure all locking nuts are tight (Loctite).
	Cleaner not set up correctly.	Ensure cleaner set up properly (check blade angle with gauge).
	Belt tension too high.	Ensure cleaner can conform to belt, or replace with alternate Flexco secondary cleaner.
	Belt flap.	Introduce hold-down roller to flatten belt.
	Cleaner over-tensioned.	Ensure cleaner is correctly tensioned.
	Cleaner under-tensioned.	Ensure cleaner is correctly tensioned.
Material buildup on cleaner.	Cleaner not set up correctly.	Ensure cleaner set up properly (check blade angle with gauge).
	Buildup on chute.	Ensure cleaner is not located too close to back of chute, allowing buildup.
	Cleaner being overburdened.	Introduce Flexco precleaner.
	Excessive sticky material.	Frequently clean unit of buildup.
Damaged belt cover.	Cleaner over-tensioned.	Ensure cleaner is correctly tensioned.
	Cleaner blade damage.	Check blade for wear, damage and chips, replace where necessary.
	Attack angle not correct.	Ensure cleaner set up properly (check blade angle with gauge).
	Material buildup in chute.	Frequently clean unit of buildup.
Cleaner not conforming to belt.	Cleaner not set up correctly.	Ensure cleaner set up properly (check blade angle with gauge).
	Belt tension too high.	Ensure cleaner can conform to belt (introduce hold-down roller), or replace with alternate Flexco secondary cleaner.
	Belt flap.	Introduce hold-down roller to flatten belt.
	Cleaner cannot conform.	Ensure cleaner can conform to belt (introduce hold-down roller), or replace with alternate Flexco secondary cleaner.
Material passing cleaner.	Cleaner not set up correctly.	Ensure cleaner set up properly (check tip angle with gauge).
	Cleaner tension too low.	Ensure cleaner is correctly tensioned.
	Cleaner blades worn/damaged.	Check blade for wear, damage and chips, replace where necessary.
	Cleaner being overburdened.	Introduce Flexco precleaner.
	Belt flap.	Introduce hold-down roller to flatten belt.
	Belt worn or grooved.	Introduce water spray pole.
	Cleaner cannot conform.	Ensure cleaner can conform to belt (introduce hold-down roller), or replace with alternate Flexco secondary cleaner.
Damage to mechanical fastener.	Belt not skived correctly.	Spot and redo splice correctly, lowering the profile flush or below belt surface.
Missing material in belt center only.	Cupped Belt.	Install hold-down roller and reset blade angle with gauge.
	Cleaner blade worn/damaged.	Check blade for wear, damage and chips, replace where necessary.
Missing material on outer edges only.	Cupped Belt.	Install hold-down roller and reset blade angle with gauge.
	Cleaner blade worn/damaged.	Check blade for wear, damage and chips, replace where necessary.

# Section 8 - Specs and CAD Drawings

## 8.1 Specs and Guidelines

### Pole Length Specifications\*

CLEANER SIZE		BLADE WIDTH		POLE LENGTH		MAXIMUM CONVEYOR SPAN	
in.	mm	in.	mm	in.	mm	in.	mm
24	600	28	700	84	2100	68	1700
30	750	34	850	90	2250	74	1850
36	900	40	1000	96	2400	80	2000
42	1050	46	1150	102	2550	86	2150
48	1200	52	1300	108	2700	92	2300
54	1350	58	1450	114	2850	98	2450
60	1500	64	1600	120	3000	104	2600
72	1800	76	1900	126	3150	116	2900
84	2100	88	2200	138	3450	128	3200
96	2400	100	2500	150	3750	140	3500

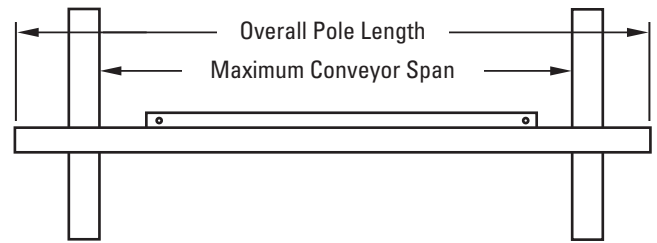

\*For special extra long pole length requirements a Pole Extender Kit (#76024) is available that provides 30" (750mm) of extended pole length. See Page 7. Pole Diameter - 2-7/8" (73mm)

### Clearance Guidelines for Installation

HORIZONTAL CLEARANCE REQUIRED		VERTICAL CLEARANCE REQUIRED	
in.	mm	in.	mm
4	100	10	250

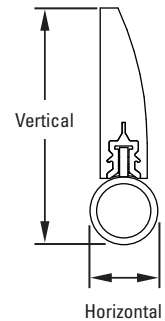

### SST XD Spring Length Chart

Blade Width		White Springs		Silver Springs		Black Springs		Gold Springs	
in.	mm	in.	mm	in.	mm	in.	mm	in.	mm
18	450	3 3/8	86	4	102	N/A	N/A	N/A	N/A
24	600	3 1/8	79	3 7/8	98	N/A	N/A	N/A	N/A
30	750	2 7/8	73	3 3/4	95	N/A	N/A	N/A	N/A
36	900	N/A	N/A	3 3/4	95	3 7/8	98	N/A	N/A
42	1050	N/A	N/A	3 5/8	92	3 3/4	95	N/A	N/A
48	1200	N/A	N/A	3 1/2	89	3 5/8	92	N/A	N/A
54	1350	N/A	N/A	3 3/8	86	3 5/8	92	3 3/4	95
60	1500	N/A	N/A	3 1/4	83	3 1/2	89	3 3/4	95
72	1800	N/A	N/A	N/A	N/A	3 3/8	86	3 5/8	92
84	2100	N/A	N/A	N/A	N/A	3 1/8	79	3 1/2	89
96	2400	N/A	N/A	N/A	N/A	N/A	N/A	3 3/8	86
108	2700	N/A	N/A	N/A	N/A	N/A	N/A	3 1/2	89
120	3000	N/A	N/A	N/A	N/A	N/A	N/A	3 3/8	86

Shading indicates preferred spring option.

### SAT XD Pressure Chart

Blade Width		Pressure	
in.	mm	psi	kPa
18	450	15	103
24	600	19	131
30	750	23	159
36	900	27	186
42	1050	31	214
48	1200	35	241
54	1350	39	269
60	1500	43	296
72	1800	51	352
84	2100	59	407
96	2400	67	462

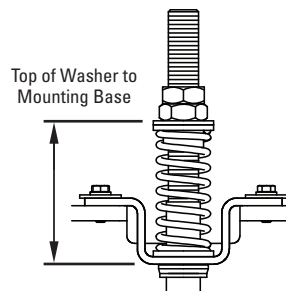

### Specifications:

- Maximum Belt Speed ..... 1000 FPM (5 M/sec)
- Temperature Rating ..... -30 to 180°F (-35 to 82°C)
- Usable Blade Wear Length ..... 4-1/2" (113mm)
- Blade Height ..... 7-1/4" (185mm)
- Blade ..... Polyurethane with UHMW additive (softer durometer to squeegee water off and additive to enhance blade life)
- Available for Belt Widths ..... 24 to 96" (600 to 2400mm) Other sizes available upon request.
- CEMA Cleaner Rating ..... Class 4

# Section 8 - Specs and CAD Drawings

## 8.2 CAD Drawing - MDWS - SST XD Tensioner

SPECIFICATIONS		MDWS SECONDARY CLEANER		MDWS BLADE		MDWS POLE		
BELT WIDTH 'A'	POLE LENGTH 'B'	ORDER NUMBER	ITEM CODE	ORDER NUMBER	ITEM CODE	ORDER NUMBER	ITEM CODE	
IN	MM							
24	600	78	1980	75868	CDWB24	75884	MSPP30	75804
30	750	84	2133	75869	CDWB30	75885	MSPP36	75805
36	900	90	2286	75870	CDWB36	75886	MSPP42	75806
42	1050	96	2438	75871	CDWB42	75887	MSPP48	75807
48	1200	102	2590	75872	CDWB48	75888	MSPP54	75808
54	1350	108	2743	75873	CDWB54	75889	MSPP60	75809
60	1500	114	2895	75874	CDWB60	75890	MSPP66	76695
72	1800	126	3200	75875	CDWB72	75891	DWP-72	75883
84	2100	138	3505	75876	CDWB84	76942	DWP-84	76815
96	2400	150	3800	79063	CDWB96	79062	DWP-96	79060
108	2700	162	4050	90175	CDWB108	90909	DWP-108	90332

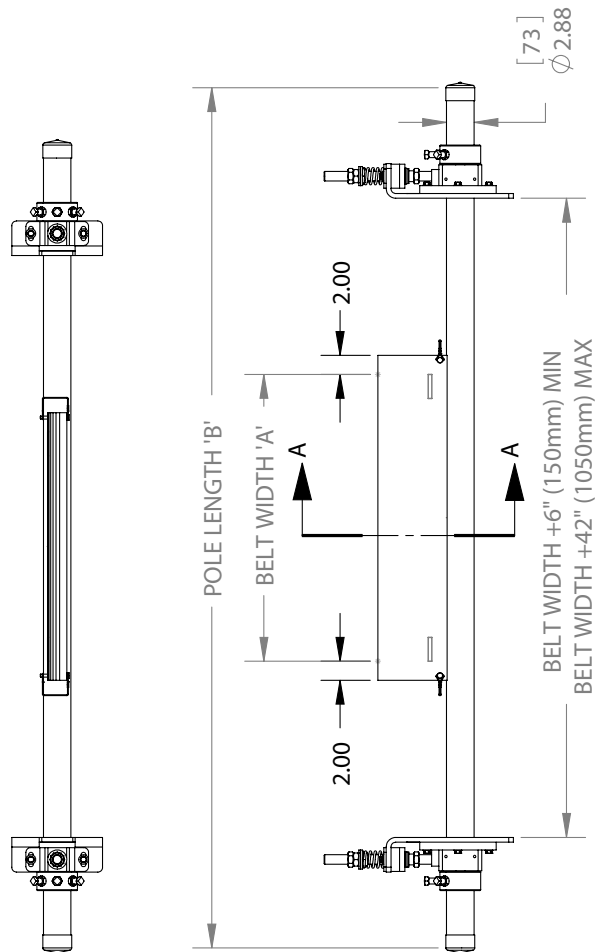
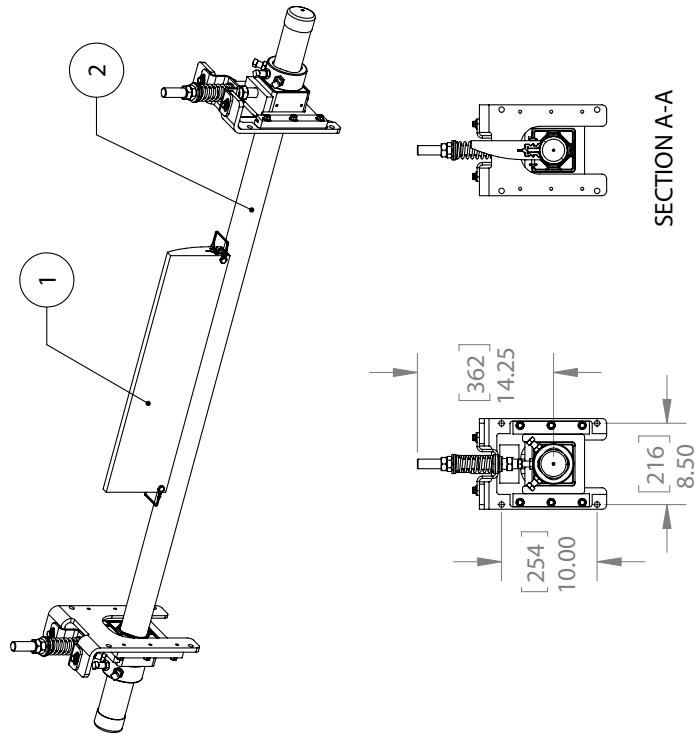

# Section 8 - Specs and CAD Drawings

## 8.3 CAD Drawing - MDWS - SAT XD Tensioner

SPECIFICATIONS		MDWS SECCLEANER - SAT XD	
BELT WIDTH 'A'	POLE LENGTH 'B'	ORDER NUMBER	ITEM CODE
IN	MM		
24	600	MDWS-24P	78745
30	750	MDWS-30P	78746
36	900	MDWS-36P	78747
42	1050	MDWS-42P	78748
48	1200	MDWS-48P	78749
54	1350	MDWS-54P	78750
60	1500	MDWS-60P	78751
72	1800	MDWS-72P	78752
84	2100	MDWS-84P	78753
96	2400	MDWS-96P	79064
108	2700	MDWS-108P	90177

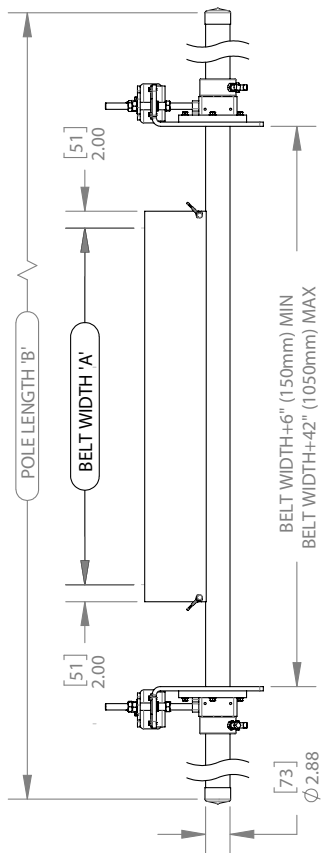
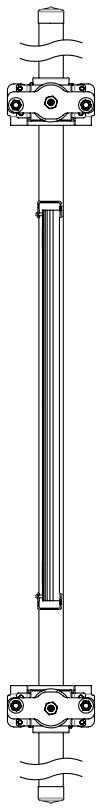
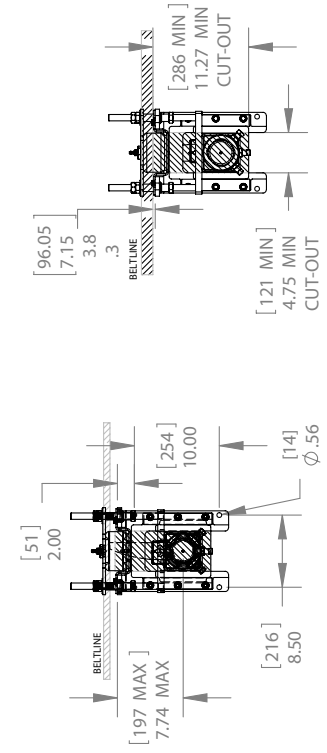
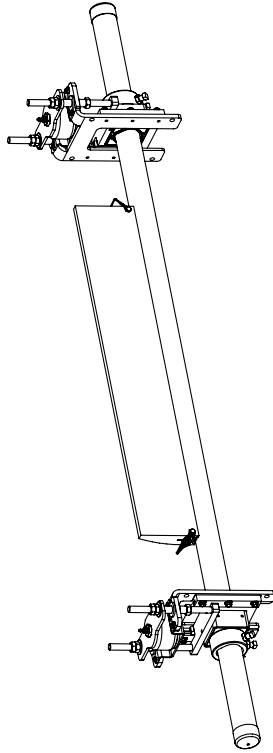

# Section 9 - Replacement Parts

## 9.1 Replacement Parts List

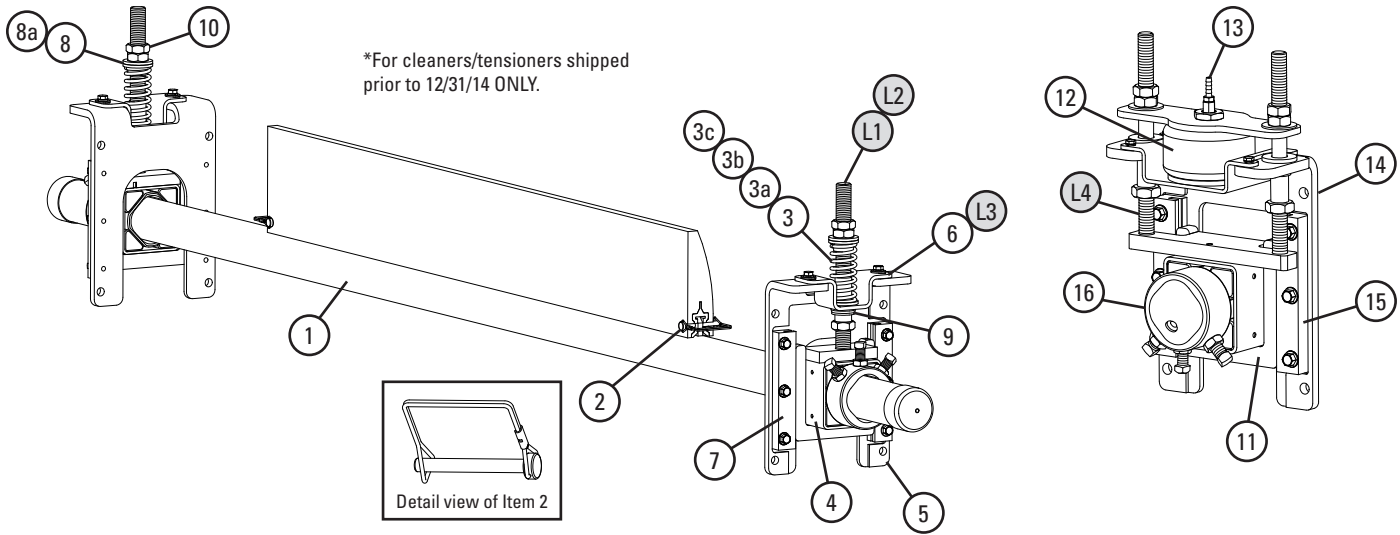

### Replacement Parts

REF	DESCRIPTION	ORDERING NUMBER	ITEM CODE	WT. LBS.
1	24" (600mm) Pole	MSPP30	75804	46.0
	30" (750mm) Pole	MSPP36	75805	50.5
	36" (900mm) Pole	MSPP42	75806	55.5
	42" (1050mm) Pole	MSPP48	75807	60.0
	48" (1200mm) Pole	MSPP54	75808	64.0
	54" (1350mm) Pole	MSPP60	75809	67.0
	60" (1500mm) Pole	MSPP66	76695	76.0
	72" (1800mm) Pole	DWP-72	75883	90.0
	84" (2100mm) Pole	DWP-84	76815	100.0
	96" (2400mm) Pole	DWP-96	79060	110.0
2	Blade Pin Kit* (1 ea.)	MSPBP	107852	0.1
3	Tension Spring - White (1 ea.) for belts 18–30" (450–750mm)	STS-W	75846	0.5
3a	Tension Spring - Silver (1 ea.) for belts 36–60" (900–1500mm)	STS-S	75843	0.8
3b	Tension Spring - Black (1 ea.) for belts 72–84" (1800–2100mm)	STS-B	75844	1.0
3c	Tension Spring - Gold (1 ea.) for belts 96" (2400mm)	STS-G	78142	1.3
4	HD Torsion Pole Mount* (1 ea.) (incl. 1 adjusting rod, 3 nuts & 1 sleeve) (See 8 & 8a for bushings)	SSTHDPM	77868	15.0
5	SST XD Mounting Base Kit* (incl. 1 mtg. base, 2 slide guides, 1 top hat bracket & 1 bottom bushing)	SSTXDMK	91412	10.2
6	SST Hat Bracket (pair)	SSTHB	79582	3.5
7	SST Slide Guide Kit* (incl. 2 slide guides)	STGK2	77867	1.1
8	SST Bushing Kit - White/Silver (incl. 2 bushings)	SSTBK-W	76636	0.1
8a	SST Bushing Kit - Black/Gold (incl. 2 bushings)	SSTBK-B	76637	0.1
9	SST Lower Bushing Kit (pair)	SSTLBK	79493	0.1
10	Jam Nut Kit SST Tensioner	JNK-C	79893	0.3
-	SST XD Spring Tensioner* - White (incl. 2 ea. items 3, 4, 5, & 8a) for belts 18–30" (450–750mm)	SSTXD-W	91408	60.6
-	SST XD Spring Tensioner* - Silver (incl. 2 ea. items 3a, 4, 5, & 8a) for belts 36–48" (900–1200mm)	SSTXD-S	91409	61.4
-	SST XD Spring Tensioner* - Black (incl. 2 ea. items 3b, 4, 5, & 8b) for belts 54–84" (1350–2100mm)	SSTXD-B	91410	62.0
-	SST XD Spring Tensioner* - Gold (incl. 2 ea. items 3c, 4, 5, & 8b) for belts 96" (2400mm)	SSTXD-G	91411	62.6

\*Hardware Included  
Lead time: 1 working day

### SAT XD Replacement Parts

REF	DESCRIPTION	ORDERING NUMBER	ITEM CODE	WT. LBS.
11	SAT XD	SATXDNCB	78703	41.0
12	SAT Air/Water Bag Kit	SATB	76083	5.1
13	SAT 1/8" Hose Barb Kit	SATHB	76084	0.1
14	SAT XD Mounting Base Kit	SATXDMK	91415	11.6
15	ST Slide Guide Kit	STGK2	77867	1.1
16	SAT2 Torsion Pole Mount (incl. threaded rods & 6 nuts)	SAT2PM	78732	11.1

Lead time: 1 working day

### Legacy Replacement Parts for Tensioners shipped prior to changeover announcement

REF	DESCRIPTION	ORDERING NUMBER	ITEM CODE	WT. LBS.
L1	Adjusting Rod Kit (incl. 1 rod, 2 nuts, 1 bushing, 1 washer) for belts 24–60" (600–1500mm)	STAK	75847	2.9
L2	HD Adjusting Rod Kit (incl. 1 rod, 2 nuts, 1 HD bushing, 1 washer) for belts 72–84" (1800–2100mm)	STAKHD	75892	3.0
L3	Legacy SST Hat Channel Kit	SSTHK	79070	1.5
L4	SAT2 Adjusting Rod Kit	SAT2AK	78733	5.0
-	SST Tensioner Bushing Update Kit (incl. 2 lower bushings, 2 sleeves, 2 nuts)	SST-BUK	76943	0.3

### Spring Tensioner Selection Chart

CLEANER SIZE	91408 SSTXD-W	91409 SSTXD-S	91410 SSTXD-B	91411 SSTXD-G
MDWS 24–30" (600–750mm)	X			
MDWS 36–60" (900–1500mm)		X		
MDWS 72–84" (1800–2100mm)			X	
MDWS 96" (2400mm)				X



## Section 10 - Other Flexco Conveyor Products

---

Flexco provides many conveyor products that help your conveyors to run more efficiently and safely. These components solve typical conveyor problems and improve productivity. Here is a quick overview on just a few of them:

### MMP Precleaner

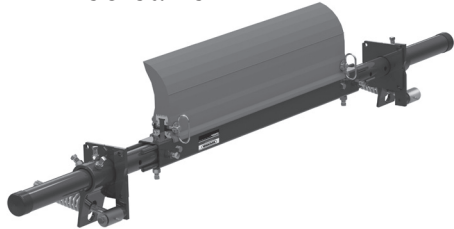

- Extra cleaning power right on the head pulley.
- A 10" (250mm) TuffShear™ blade provides increased blade tension on the belt to peel off abrasive materials.
- The unique Visual Tension Check™ ensures optimal blade tensioning and quick, accurate retensioning.
- Easy to install and simple to service.

### DRX™ Impact Beds



- Exclusive Velocity Reduction Technology™ to better protect the belt.
- Slide-Out Service™ gives direct access to all impact bars for change-out.
- Impact bar supports for longer bar life.
- 4 models to custom fit to the application.

### MHS Secondary Cleaner with Service Advantage Cartridge

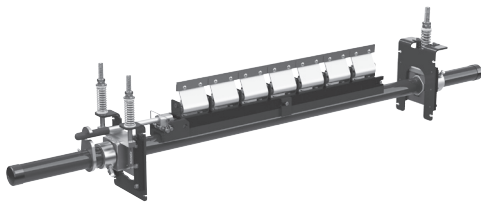

- An easy slide-out cartridge for service.
- Cartridge design to speed up blade-change maintenance.
- Patented PowerFlex™ Cushions for superior cleaning performance.
- Compatible with Flexco mechanical splices.

### PT Max™ Belt Trainer



- Patented “pivot & tilt” design for superior training action.
- Dual sensor rollers on each side to minimize belt damage.
- Pivot point guaranteed not to seize or freeze up.
- Available for topside and return side belts.

### Flexco Specialty Belt Cleaners



- “Limited space” cleaners for tight conveyor applications.
- High Temp cleaners for severe, high heat applications.
- A rubber fingered cleaner for chevron and raised rib belts.
- Multiple cleaner styles in stainless steel for corrosive applications.

### Belt Plows



- A belt cleaner for the tail pulley.
- Exclusive blade design quickly spirals debris off the belt.
- Economical and easy to service.
- Available in vee or diagonal models.





Visit [www.flexco.com](http://www.flexco.com) for other Flexco locations and products, or to find an authorized distributor.

©2023 Flexible Steel Lacing Company. 09-13-24. X2508

