

EZP1T Precleaner

Installation, Operation and Maintenance Manual



EZP1T Precleaner

Serial Number: _____
Purchase Date: _____
Purchased From: _____
Installation Date: _____

Serial number information can be found on the Serial Number Label included in the Information Packet found in the cleaner carton.

This information will be helpful for any future inquiries or questions about belt cleaner replacement parts, specifications or troubleshooting.

Table of Contents

Section 1 – Important Information	2
1.1 General Introduction	2
1.2 User Benefits	2
1.3 Service Option	2
Section 2 – Safety Considerations and Precautions	3
2.1 Stationary Conveyors.....	3
2.2 Operating Conveyors	3
Section 3 – Pre-Installation Checks and Options.....	4
3.1 Checklist	5
3.2 Cleaner Location Adjustments	5
Section 4 – Installation Instructions.....	6
Section 5 – Pre-Operation Checklist and Testing.....	9
5.1 Pre-Op Checklist	9
5.2 Test Run the Conveyor	9
Section 6 – Maintenance	10
6.1 New Installation Inspection	10
6.2 Routine Visual Inspection	10
6.3 Routine Physical Inspection.....	10
6.4 Blade Replacement Instructions.....	11
6.5 Maintenance Log	13
6.6 Cleaner Maintenance Checklist.....	14
Section 7 – Troubleshooting	15
Section 8 – Specifications and CAD Drawings.....	16
8.1 EZP1T Precleaner CAD drawing- Belt Width -2"	17
8.2 EZP1T Precleaner CAD drawing- Belt Width -8"	18
Section 9 – Replacement Parts	19
Section 10 – Other Flexco Conveyor Products	21

Section 1 – Important Information

1.1 General Introduction

We at Flexco are very pleased that you have selected an EZP1T Precleaner for your conveyor system.

This manual will help you to understand the operation of this product and assist you in making it work up to its maximum efficiency over its lifetime of service.

It is essential for safe and efficient operation that the information and guidelines presented be properly understood and implemented. This manual will provide safety precautions, installation instructions, maintenance procedures and troubleshooting tips.

If, however, you have any questions or problems that are not covered, please contact your field representative or our Customer Service Department:

Customer Service: 1-800-541-8028

Visit www.flexco.com for other Flexco locations and products.

Please read this manual thoroughly and pass it on to any others who will be directly responsible for installation, operation and maintenance of this cleaner. While we have tried to make the installation and service tasks as easy and simple as possible, **it does however require correct installation and regular inspections and adjustments to maintain top working condition.**

1.2 User Benefits

Correct installation and regular maintenance will provide the following benefits for your operation:

- Reduced conveyor downtime
- Reduced man-hour labor
- Lower maintenance budget costs
- Increased service life for the belt cleaner and other conveyor components

1.3 Service Option

The EZP1T Precleaner is designed to be easily installed and serviced by your on-site personnel. However, if you would prefer complete turn-key factory service, please contact your local Flexco Field Representative.

Section 2 – Safety Considerations and Precautions

Before installing and operating the EZP1T Precleaner, it is important to review and understand the following safety information.

There are set-up, maintenance and operational activities involving both **stationary** and **operating** conveyors. Each case has a safety protocol.

2.1 Stationary Conveyors

The following activities are performed on stationary conveyors:

- Installation
- Blade replacement
- Repairs
- Tension adjustments
- Cleaning

DANGER

It is imperative that OSHA/MSHA Lockout/Tagout (LOTO) regulations, 29 CFR 1910.147, be followed before undertaking the preceding activities. Failure to use LOTO exposes workers to uncontrolled behavior of the belt cleaner caused by movement of the conveyor belt. Severe injury or death can result.

Before working:

- Lockout/Tagout the conveyor power source
- Disengage any takeups
- Clear the conveyor belt or clamp securely in place

WARNING

Use Personal Protective Equipment (PPE):

- Safety eyewear
- Hardhats
- Safety footwear

Close quarters, springs and heavy components create a worksite that compromises a worker's eyes, feet and skull.

PPE must be worn to control the foreseeable hazards associated with conveyor belt cleaners. Serious injuries can be avoided.

2.2 Operating Conveyors

There are two routine tasks that must be performed while the conveyor is running:

- Inspection of the cleaning performance
- Dynamic troubleshooting

DANGER

Every belt cleaner is an in-running nip hazard. Never touch or prod an operating cleaner. Cleaner hazards cause instantaneous amputation and entrapment.

WARNING

Belt cleaners can become projectile hazards. Stay as far from the cleaner as practical and use safety eyewear and headgear. Missiles can inflict serious injury.

WARNING

Never adjust anything on an operating cleaner. Unforeseeable belt projections and tears can catch on cleaners and cause violent movements of the cleaner structure. Flailing hardware can cause serious injury or death.

Section 3 – Pre-installation Checks and Options

3.1 Checklist

- Check that the cleaner size is correct for the beltline width
- Check the belt cleaner carton and make sure all the parts are included
- Review the “Tools Needed” list on the top of the installation instructions
- Check the conveyor site:
 - Will the cleaner be installed on a chute
 - Is the install on an open head pulley requiring mounting structure
 - Are there obstructions that may require cleaner location adjustments (see 3.2 – Cleaner Location Adjustments)

Section 3 – Pre-installation Checks and Options

3.2 Cleaner Location Adjustments

In certain applications it is necessary to modify the location of the precleaner pole due to permanent obstacles that obstruct the desired location. Relocating the pole location can be done easily and does not hinder the performance of the cleaner as long as the “C” dimension is maintained.

NOTE: In the following example we will be lowering the pole location in the “Y” direction, but the same method could also be applied in the “X” direction.

Conveyor situation:

Pulley Diameter: 24"

X = 12"

Y = 9"

C = 15"

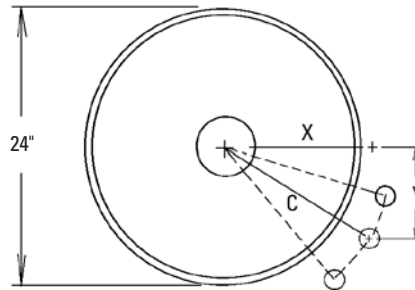

- Determine the given location dimensions and define the change needed.** After laying out the given X & Y dimensions, determine the distance of the modification required for adequate clearance of the pole and tensioning system. (In the example we decide to lower the pole 2" (50mm) to clear the support structure).
- Write down known dimensions.** We can now determine two of the three required dimensions which will allow us to find the third. We know we cannot alter the “C” dimension, so this will remain the same. Also we are required to lower the unit in the “Y” dimension 2" (50mm), so we add 2" (50mm) to the given “Y” dimension.

$$X = ?$$

$$Y = 9 + 2 = 11"$$

$$C = 15"$$

- Determine final dimension.** On a flat vertical surface, using a level, draw one horizontal line and one vertical line creating a right triangle (Fig 3a). Measure down from the intersection the determined “Y” dimension and mark (Fig 3b). With the tape measure starting at the modified “Y” mark, swing the tape across the “X” line and mark at the “C” dimension where it crosses the “X” line (Fig 3c). Measure from the intersection to the “C” intersection and this will be your new “X” dimension (Fig. 3d).

$$X = 10 \frac{1}{4}"$$

$$Y = 11"$$

$$C = 15"$$

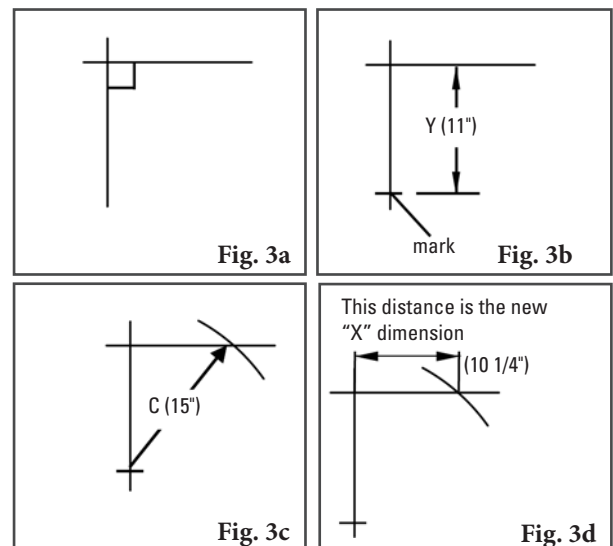

Section 4 – Installation Instructions

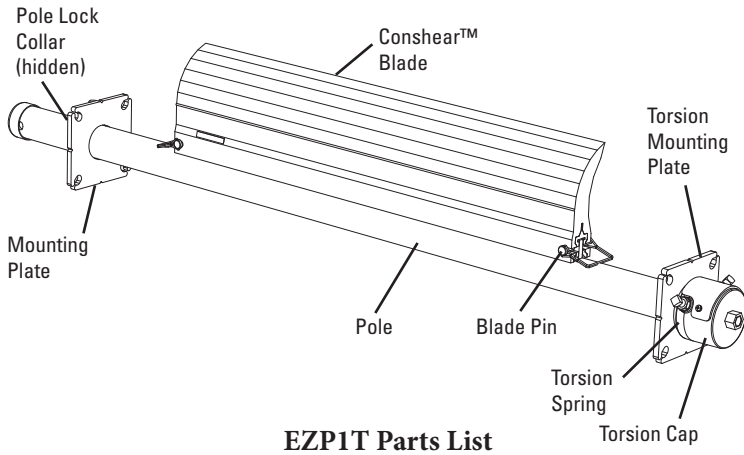

EZP1T Parts List

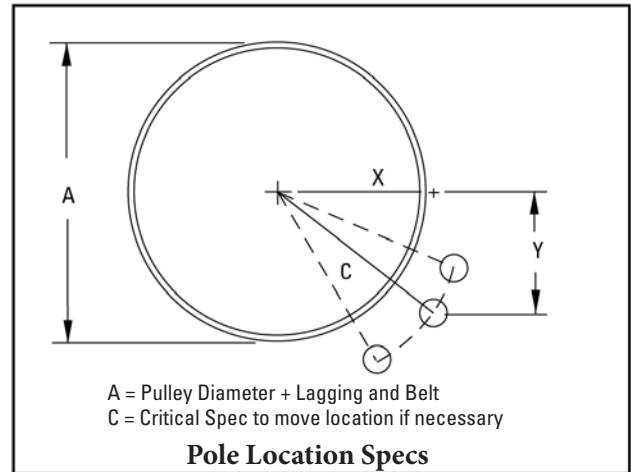

Physically lock out and tag the conveyor at the power source before you begin cleaner installation.

Installation specs and instructions are based on the assumption that the conveyor is in its working position (angle). If the conveyor angle will be different, the cleaner should be installed per the final position. Call the BCP Helpline 1-800-253-8132 if you need help on determining the proper coordinates.

Tools Needed:

- 1/4" allen wrench
- 15/16" wrench for standard tensioner
- 1 1/8" wrench for heavy duty tensioner
- 3/4" wrench or crescent wrench
- 1/2" wrench or crescent wrench
- cutting torch
- grinder

1. Locate the correct pole position. Measure and determine Dimension A (see instructions above). Find Dimension A on the Pole Location Chart at right and determine Dimensions X, Y and C. Measure out horizontally from the center of the pulley shaft Dim X and mark. From that mark, draw a long vertical line down, then measure and mark Dim Y. This indicates the location of the center of the cleaner pole. Measure and mark both sides. **NOTE:** If the location is obstructed, use Dim. C and move on an arc from the center of the pulley shaft to find an open position. Dim. C must remain constant to correctly locate the pole (see drawing above). **NOTE:** For open head installs, first add mounting support materials to the structure.

2. Mark and cut the mounting plate holes. Using the mounting plate template provided in the instruction packet, position the large pole access hole on the chute, aligning the hole notches with the layout lines. Position the keyway toward the pulley. Trace the pole cutout and mounting holes (Fig. 1). Cut the holes on both sides of the chute.

NOTE: Hole cutouts are slotted for later adjustment if needed.

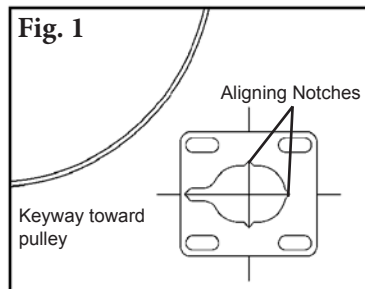

Pole Location Chart

A	X	Y	C
10"	3"	9"	9 1/2"
11"	3 3/4"	9"	9 3/4"
12"	4 3/8"	9"	10"
13"	5 3/8"	9"	10 1/2"
14"	5 7/8"	9"	10 3/4"
15"	6 3/4"	9"	11 1/4"
16"	7 1/8"	9"	11 1/2"
17"	7 7/8"	9"	12"
18"	8 1/4"	9"	12 1/4"
19"	9"	9"	12 3/4"
20"	9 3/8"	9"	13"
21"	10"	9"	13 1/2"
22"	10 3/4"	9"	14"
23"	11 3/8"	9"	14 1/2"
24"	12"	9"	15"
25"	12 5/8"	9"	15 1/2"
26"	13 1/4"	9"	16"
27"	13 7/8"	9"	16 1/2"
28"	14 3/8"	9"	17"
29"	15"	9"	17 1/2"
30"	15 5/8"	9"	18"
31"	16 1/8"	9"	18 1/2"
32"	16 3/4"	9"	19"
33"	17 1/4"	9"	19 1/2"
34"	17 7/8"	9"	20"
35"	18 3/8"	9"	20 1/2"
36"	19"	9"	21"

Section 4 – Installation Instructions (cont.)

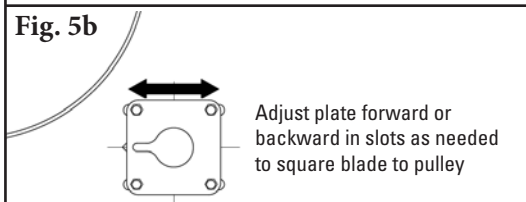
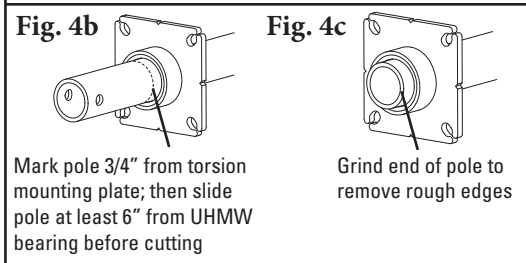
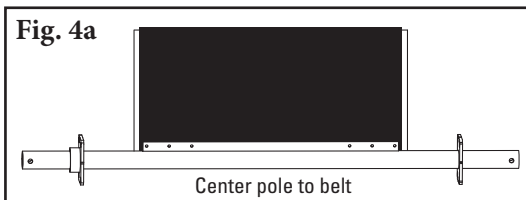
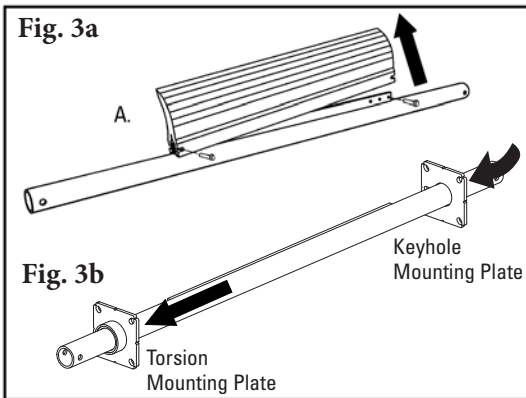
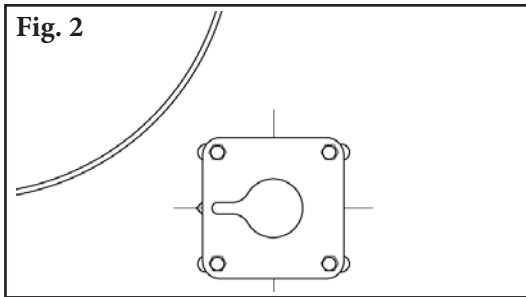

3. **Install the mounting plates.** Bolt flat mounting plate (with keyhole) to the side opposite where the tensioner will be mounted. Keyhole should face the pulley (Fig. 2). Install torsion mounting plate (with circular weldment) to the tensioner side. Center plates on the slotted holes and tighten bolts.
4. **Install the pole.** Remove both blade pins and blade from the pole (Fig. 3a) and insert the pole in through the mounting plates (starting with keyhole plate) (Fig. 3b).
5. **Center pole to the belt (Fig. 4a).** Mark pole 3/4" outside torsion mounting plate (Fig. 4b). Feed pole further through torsion mounting plate so pole can be cut on the mark (slide pole away from UHMW bearing at least 6" before cutting to prevent melting.) After cut is made, grind end of pole clean from rough edges (Fig. 4c).
6. **Reinstall blade.** Reinstall blade with both blade pins. Center the blade on the belt. Rotate the blade up to the belt and check to insure that the blade is square to the pulley face (Fig. 5a). If not, loosen a mounting plate on one side and adjust the plate forward or backward to square the blade to the pulley, and retighten the bolts (Fig. 5b).
7. **Install the tensioner.** Slide torsion spring assembly into cut end of pole until fully engaged with the pole (Fig. 6a). Hold blade against pulley and rotate indicator mark until it is vertical. Tighten set screws with 1/4" allen wrench (Fig. 6b).

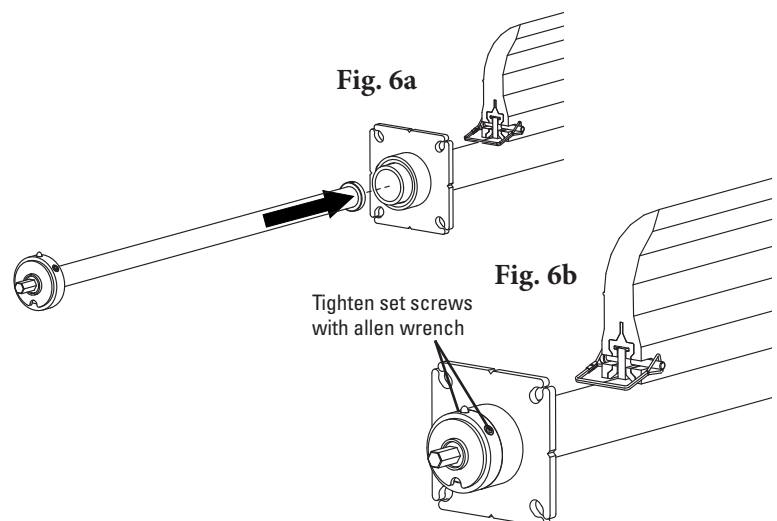

Section 4 – Installation Instructions (cont.)

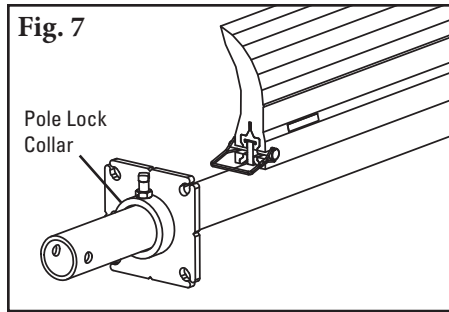

8. **Lock pole with collar.** Ensure pole is flush (no space) on tensioner side. Install and tighten pole lock collar on non-tensioned side (Fig. 7).

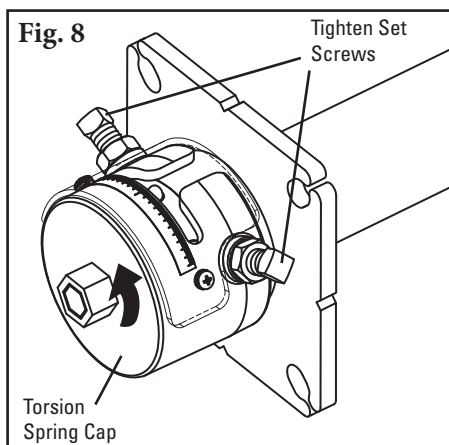

Twist Tensioner Chart

Blade Width	Standard	Heavy Duty
10"	8	6
16"	13	9
22"	18	12
28"	23	16
34"	27	19
40"	32	23
46"	37	26
52"	N/A	29
58"	N/A	33
64"	N/A	36
70"	N/A	40

9. **Set the blade tension.** While holding the blade to the belt, place cap over spring. Use wrench on center hex shaft to apply tension to spring at desired angle (see chart). While holding tension with wrench, tighten the two set screws (Fig. 8).

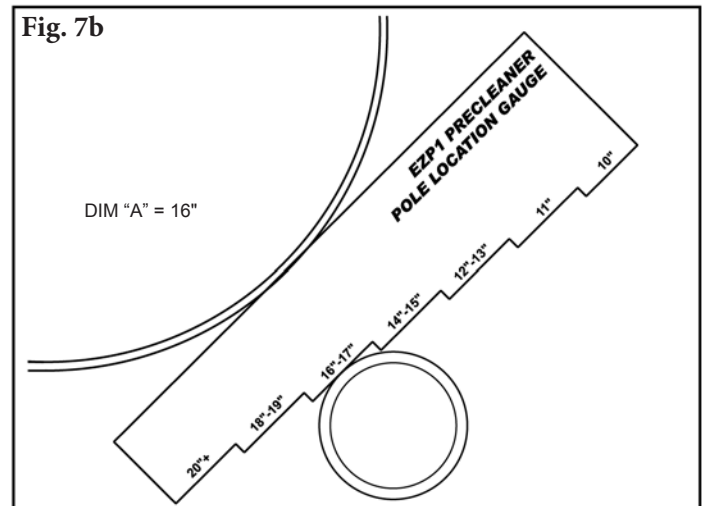
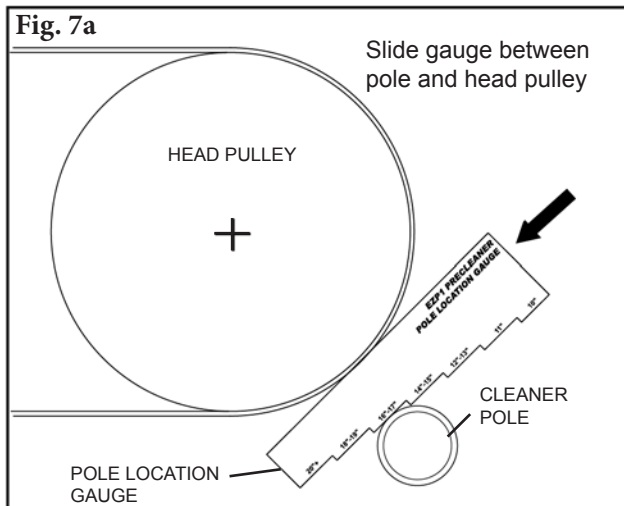

10. **Confirm correct pole location.** After the cleaner is installed, slide the Pole Location Gauge (provided in the instruction packet) between the cleaner pole and the pulley, until it stops at a step (Fig. 9a). Read the flat area where the pole is resting (Fig. 9b.) This diameter should be equal to Dim A used in Step 1.

NOTE: If the diameter reading on the Pole Location Gauge does not read the same as in Step 1, check the "C" dimension and correct accordingly.

Test run the cleaner and inspect the performance. If vibration occurs or more cleaning efficiency is desired, make the necessary tensioning adjustments.

Section 5 – Pre-Operation Checklist and Testing

5.1 Pre-Op Checklist

- Recheck that all fasteners are tightened properly
- Add pole caps
- Apply all supplied labels to the cleaner
- Check the blade location on the belt
- Be sure that all installation materials and tools have been removed from the belt and the conveyor area

5.2 Test Run the Conveyor

- Run the conveyor for at least 15 minutes and inspect the cleaning performance
- Check the tensioner spring for recommended length (proper tensioning)
- Make adjustments as necessary

NOTE: Observing the cleaner when it is running and performing properly will help to detect problems or when adjustments are needed later.

Section 6 – Maintenance

Flexco belt cleaners are designed to operate with minimum maintenance. However, to maintain superior performance some service is required. When the cleaner is installed a regular maintenance program should be set up. This program will ensure that the cleaner operates at optimal efficiency and problems can be identified and fixed before the cleaner stops working.

All safety procedures for inspection of equipment (stationary or operating) must be observed. The EZP1T Precleaner operates at the discharge end of the conveyor and is in direct contact with the moving belt. Only visual observations can be made while the belt is running. Service tasks can be done only with the conveyor stopped and by observing the correct lockout/tagout procedures.

6.1 New Installation Inspection

After the new cleaner has run for a few days a visual inspection should be made to ensure the cleaner is performing properly. Make adjustments as needed.

6.2 Routine Visual Inspection (every 2-4 weeks)

A visual inspection of the cleaner and belt can determine:

- If the spring length is the correct length for optimal tensioning.
- If the belt looks clean or if there are areas that are dirty.
- If the blade is worn out and needs to be replaced.
- If there is damage to the blade or other cleaner components.
- If fugitive material is built up on the cleaner or in the transfer area.
- If there is cover damage to the belt.
- If there is vibration or bouncing of the cleaner on the belt.
- If a snub pulley is used, a check should be made for material buildup on the pulley.

If any of the above conditions exist, a determination should be made on when the conveyor can be stopped for cleaner maintenance.

6.3 Routine Physical Inspection (every 6-8 weeks)

When the conveyor is not in operation and properly locked and tagged out a physical inspection of the cleaner to perform the following tasks:

- Clean material buildup off of the cleaner blade and pole.
- Closely inspect the blade for wear and any damage. Replace if needed.
- Check both blade pins for proper installation and condition. Replace if needed.
- Ensure full blade to belt contact.
- Inspect the cleaner pole for damage.
- Inspect all fasteners for tightness and wear. Tighten or replace as needed.
- Replace any worn or damaged components.
- Check the tension of the cleaner blade to the belt. Adjust the tension if necessary using the chart on the cleaner or the one on page 8.
- When maintenance tasks are completed, test run the conveyor to ensure the cleaner is performing properly.

Section 6 – Maintenance (cont.)

6.4 Blade Replacement Instructions

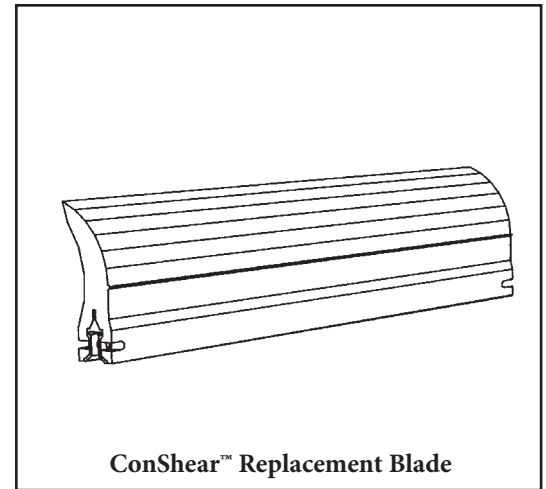
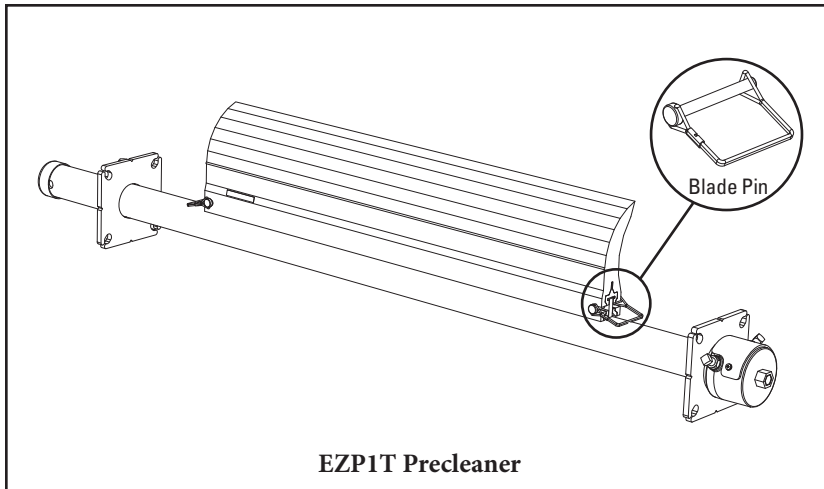

Physically lock out and tag the conveyor at the power source before you begin cleaner installation.

Tools Needed:

- 15/16" wrench for standard tensioner
- 1 1/8" wrench for heavy duty tensioner
- 3/4" wrench or crescent wrench
- 1/2" wrench or crescent wrench
- Wire brush (for cleaning pole)
- Small putty knife (for cleaning pole)

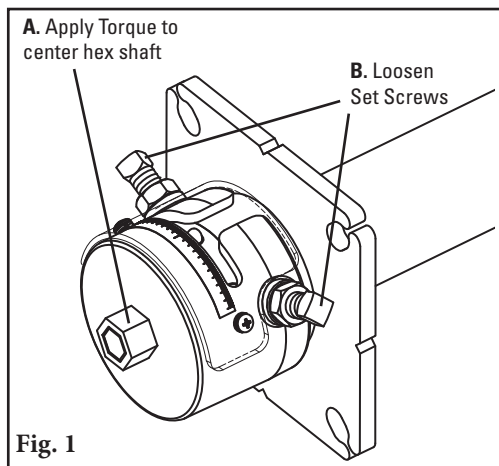

1. **Remove the tension. WARNING:** Apply torque to center hex shaft prior to release of set screws (Fig. 1). Failure to do so will result in immediate tension release and can damage the mechanism.

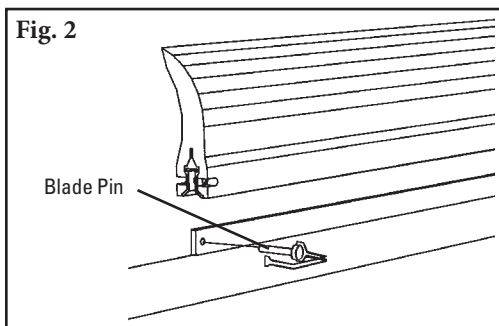

2. **Remove the worn blade.** Remove one blade pin and remove the blade from the pole (Fig. 2). Clean all fugitive material from the pole.

NOTE: If blade is hard to remove use a screwdriver or hammer to loosen it and then remove.

Section 6 – Maintenance (cont.)

6.4 Blade Replacement Instructions

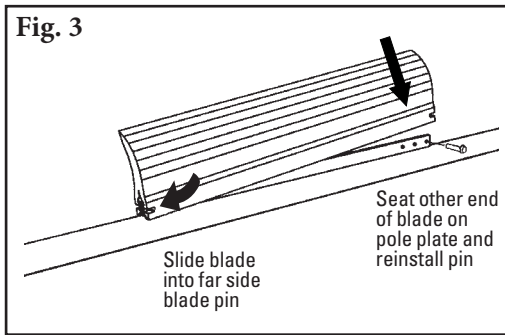

- 3. Install the new blade.** Slide the new blade onto the pole, locking it into the far blade pin, then reinstall the removed blade pin, washer and clip (Fig. 3).

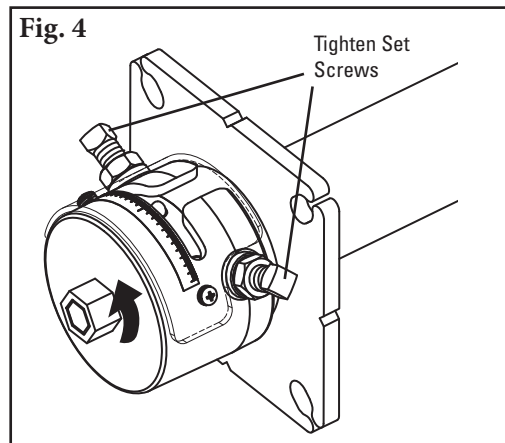

- 4. Reset the correct blade tension.** While holding the blade to the belt, use wrench on center hex shaft to apply tension to spring at desired angle (see chart). While holding tension with wrench, tighten the two set screws (Fig. 4).

Test run the cleaner. Run the conveyor for at least 15 minutes and inspect the cleaning performance. Make adjustments as necessary.

Twist Tensioner Chart

Blade Width	Standard	Heavy Duty
10"	8	6
16"	13	9
22"	18	12
28"	23	16
34"	27	19
40"	32	23
46"	37	26
52"	N/A	29
58"	N/A	33
64"	N/A	36
70"	N/A	40

Section 6 – Maintenance (cont.)

6.5 Maintenance Log

Conveyor Name/No. _____

Date: _____ Work done by: _____ Service Quote #: _____

Activity: _____

Date: _____ Work done by: _____ Service Quote #: _____

Activity: _____

Date: _____ Work done by: _____ Service Quote #: _____

Activity: _____

Date: _____ Work done by: _____ Service Quote #: _____

Activity: _____

Date: _____ Work done by: _____ Service Quote #: _____

Activity: _____

Date: _____ – _____ Work done by: _____ Service Quote #: _____

Activity: _____

Date: _____ – _____ Work done by: _____ Service Quote #: _____

Activity: _____

Section 6 – Maintenance (cont.)

6.6 Cleaner Maintenance Checklist

Site: _____ Inspected by: _____ Date: _____

Belt Cleaner: _____ Serial Number: _____

Blade Width: Belt minus 2" (50mm) Belt minus 8" (200mm) Belt minus 14" (350mm)

Beltline Information:

Beltline Number: _____ Belt Condition: _____

Belt Width: 300mm (12") 450mm (18") 600mm (24") 750mm (30") 900mm (36") 1050mm (42") 1200mm (48") 1350mm (54") 1500mm (60") 1800mm (72")

Head Pulley Diameter (Belt & Lagging): _____ Belt Speed: _____ fpm or m/s Belt Thickness: _____

Belt Splice: _____ Condition of Splice: _____ Number of Splices: _____ Skived Unskived

Material conveyed: _____

Days per week run: _____ Hours per day run: _____

Blade Life:

Date blade installed: _____ Date blade inspected: _____ Estimated blade life: _____

Is blade making complete contact with belt? Yes No

Distance from wear line: Left _____ Middle _____ Right _____

Blade condition: Good Grooved Smiled Not contacting belt Damaged

Measurement of spring: Required _____ Currently _____

Was Cleaner Adjusted: Yes No

Pole Condition: Good Bent Worn

Lagging: Side Lag Ceramic Rubber Other None

Condition of lagging: Good Bad Other _____

Cleaner's Overall Performance: (Rate the following 1 - 5, 1= very poor - 5 = very good)

Appearance: Comments: _____

Location: Comments: _____

Maintenance: Comments: _____

Performance: Comments: _____

Other comments: _____

Section 7 – Troubleshooting

Problem	Possible Cause	Possible Solutions
Poor cleaning performance	Cleaner under-tensioned	Adjust to correct tension – see twist tensioner chart
	Cleaner over-tensioned	Adjust to correct tension – see twist tensioner chart
	Cleaner installed in wrong location	Verify "C" dimension, relocate to correct dimension
	Cleaner blade worn or damaged	Replace cleaner blade
Rapid Blade Wear	Tension on cleaner too high/low	Adjust to correct tension – see twist tensioner chart
	Cleaner not located correctly	Check cleaner location for correct dimensions
	Blade attack angle incorrect	Check cleaner location for correct dimensions
	Material too abrasive for blade	Option: switch to alternate cleaner with metal blades
	Mechanical splice damaging blade	Repair, skive or replace splice
Center wear on blade (smile effect)	Blade wider than material path	Replace blade with width to match material path
	Tension on cleaner too high/low	Adjust to correct tension – see twist tensioner chart
Unusual wear or damage to blade	Mechanical splice damaging blade	Repair, skive or replace splice
	Belt damaged or ripped	Repair or replace belt
	Cleaner not correctly located	Verify "C" dimension, relocate to correct dimension
	Damage to pulley or pulley lagging	Repair or replace pulley
Vibration or noise	Cleaner not located correctly	Verify "C" dimension, relocate to correct dimension
	Blade attack angle incorrect	Verify "C" dimension, relocate to correct dimension
	Cleaner running on empty belt	Use a spray pole when the belt is empty
	Cleaner tension too high/low	Adjust to correct tension or slight adjust to diminish
	Cleaner locking bolts not secure	Check and tighten all bolts and nuts
	Cleaner not square to head pulley	Verify "C" dimension, relocate to correct dimension
	Material buildup in chute	Clean up build-up on cleaner and in chute
Cleaner being pushed away from pulley	Cleaner tension not set correctly	Ensure correct tension/increase tension slightly
	Sticky material is overburdening cleaner	Increase tension; replace with cleaner with metal tips; replace with larger size cleaner
	Cleaner not set up correctly	Confirm location dimensions are equal on both sides

Section 8 – Specifications and CAD Drawings

Pole Length Specifications

Cleaner Size		Pole Length		Maximum Conveyor Span	
in.	mm	in.	mm	in.	mm
12	300	42	1050	37	925
18	450	48	1200	43	1075
24	600	54	1350	49	1225
30	750	60	1500	55	1375
36	900	66	1650	61	1525
42	1050	72	1800	67	1675
48	1200	78	1950	73	1825
54	1350	88	2200	83	2075
60	1500	94	2350	89	2225
72	1800	106	2650	101	2525

Pole Diameter - 2-3/8" (60mm)

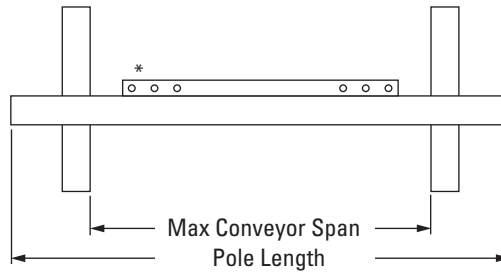

*Each pole size can be used with a blade size either belt width minus 2", belt width minus 8", or belt width minus 14".

Clearance Guidelines For Installation

Horizontal Clearance Required		Vertical Clearance Required	
in.	mm	in.	mm
4	100	9 1/2	238

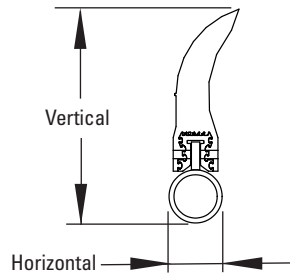

Pole Location Specs

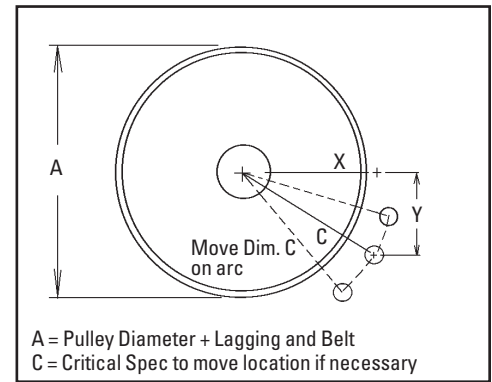

A = Pulley Diameter + Lagging and Belt
C = Critical Spec to move location if necessary

Twist Tensioner Chart

Blade Width	Standard	Heavy Duty
10"	8	6
16"	13	9
22"	18	12
28"	23	16
34"	27	19
40"	32	23
46"	37	26
52"	N/A	29
58"	N/A	33
64"	N/A	36
70"	N/A	40

Pole Location Chart

A	X	Y	C
10"	3"	9"	9 1/2"
11"	3 3/4"	9"	9 3/4"
12"	4 3/8"	9"	10"
13"	5 3/8"	9"	10 1/2"
14"	5 7/8"	9"	10 3/4"
15"	6 3/4"	9"	11 1/4"
16"	7 1/8"	9"	11 1/2"
17"	7 7/8"	9"	12"
18"	8 1/4"	9"	12 1/4"
19"	9"	9"	12 3/4"
20"	9 3/8"	9"	13"
21"	10"	9"	13 1/2"
22"	10 3/4"	9"	14"
23"	11 3/8"	9"	14 1/2"
24"	12"	9"	15"
25"	12 5/8"	9"	15 1/2"
26"	13 1/4"	9"	16"
27"	13 7/8"	9"	16 1/2"
28"	14 3/8"	9"	17"
29"	15"	9"	17 1/2"
30"	15 5/8"	9"	18"
31"	16 1/8"	9"	18 1/2"
32"	16 3/4"	9"	19"
33"	17 1/4"	9"	19 1/2"
34"	17 7/8"	9"	20"
35"	18 3/8"	9"	20 1/2"
36"	19"	9"	21"

Specifications:

- Maximum Belt Speed.....700 FPM (3.5 m/s)
- Temperature Rating.....-30°F to 180°F (-35°C to 82°C)
- Minimum Pulley Diameter.....10" (250mm)
- Blade Height.....7-1/4" (185mm)
- Usable Blade Wear Length.....4" (100mm)
- Blade Material.....Urethane (proprietary blend for abrasion resistance and long wear)
- Available for Belt Widths.....12" to 72" (300 to 1800mm)

U.S. Patent No. D482,508S

Section 8 – Specifications and CAD Drawings (cont.)

8.1 EZP1T - Belt Width Minus 2" (50mm)

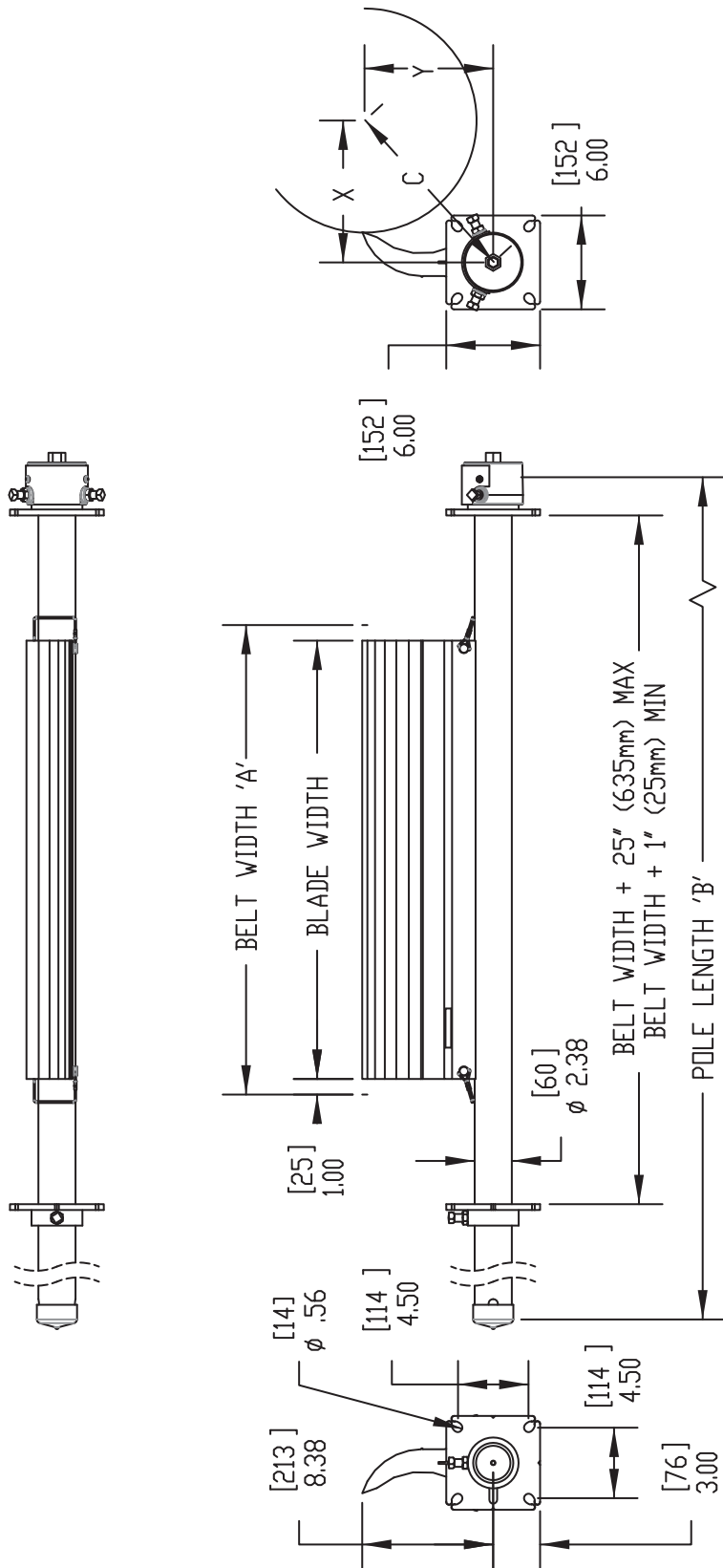

SPECIFICATIONS		EZPT-2 CLEANER ASSY		ITEM NUMBER POLE ①		ITEM NUMBER BLADE ②	
BELT WIDTH 'A' (mm)	POLE LENGTH 'B' (mm)	ORDER NUMBER	ITEM CODE	ORDER NUMBER	ITEM CODE	ORDER NUMBER	ITEM CODE
12	42	EZPT-212	78488	EZPIP12	75619	CRB10	75628
18	48	EZPT-218	78489	EZPIP18	75620	CRB16	75629
24	54	EZPT-224	78490	EZPIP24	75621	CRB22	75630
30	60	EZPT-230	78491	EZPIP30	75622	CRB28	75631
36	66	EZPT-236	78492	EZPIP36	75623	CRB34	75632
42	72	EZPT-242	78493	EZPIP42	75624	CRB40	75633
48	78	EZPT-248	78494	EZPIP48	75625	CRB46	75634
54	84	EZPT-254	78495	EZPIP54	75626	CRB52	75635
60	90	EZPT-260	78496	EZPIP60	75627	CRB58	75636
72	106	EZPT-272	78497	EZPIP72	75772	CRB70	75773



Section 8 – Specifications and CAD Drawings (cont.)

8.2 EZP1T - Belt Width Minus 8"(200mm)

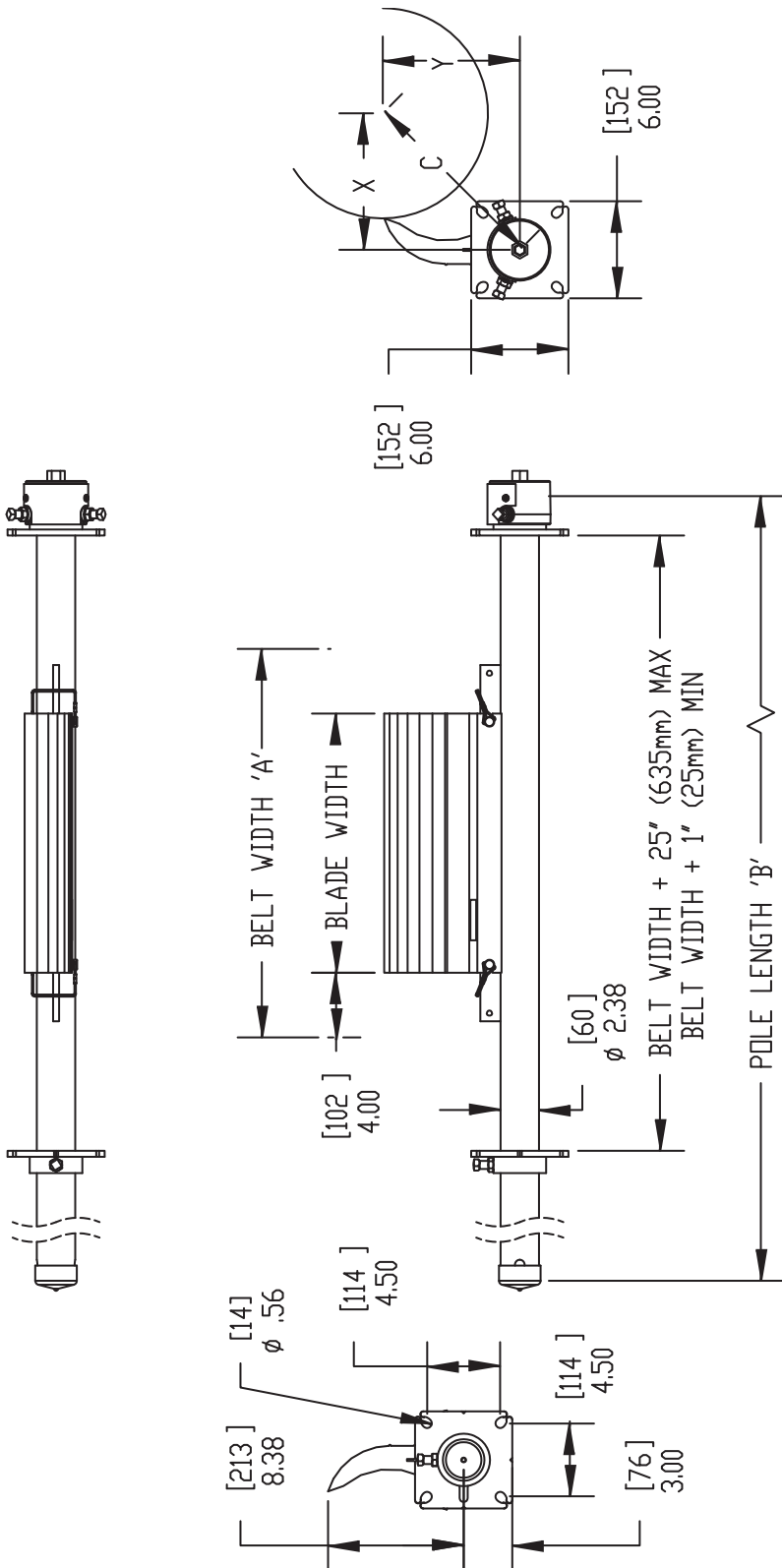

SPECIFICATIONS		EZPT-8 CLEANER ASSY		ITEM NUMBER POLE ①		ITEM NUMBER BLADE ②	
BELT WIDTH 'A' (in)	POLE LENGTH 'B' (mm)	ORDER NUMBER	ITEM CODE	ORDER NUMBER	ITEM CODE	ORDER NUMBER	ITEM CODE
18	48	EZPT-818	78498	EZPT-18	75620	CRB10	75628
24	60	EZPT-824	78499	EZPT-24	75621	CRB16	75629
30	75	EZPT-830	78500	EZPT-30	75622	CRB22	75630
36	90	EZPT-836	78501	EZPT-36	75623	CRB28	75631
42	105	EZPT-842	78502	EZPT-42	75624	CRB34	75632
48	120	EZPT-848	78503	EZPT-48	75625	CRB40	75633
54	135	EZPT-854	78504	EZPT-54	75626	CRB46	75634
60	150	EZPT-860	78505	EZPT-60	75627	CRB52	75635
72	180	EZPT-872	78506	EZPT-72	75772	CRB64	75775

Section 9 – Replacement Parts

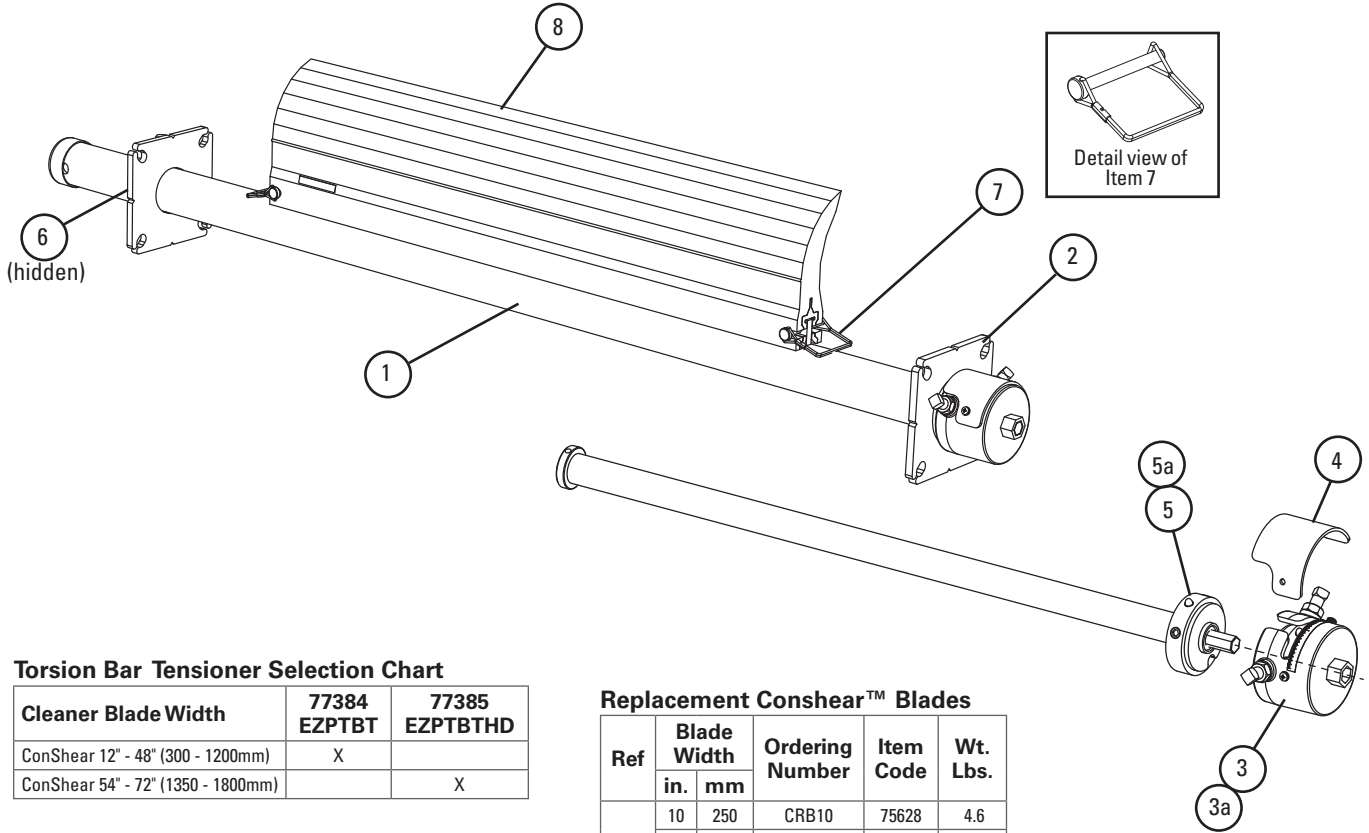

Torsion Bar Tensioner Selection Chart

Cleaner Blade Width	77384 EZPTBT	77385 EZPTBTHD
ConShear 12" - 48" (300 - 1200mm)	X	
ConShear 54" - 72" (1350 - 1800mm)		X

Replacement Parts

Ref	Description	Ordering Number	Item Code	Wt. Lbs.
1	12" (300mm) Pole	EZP1P12	75619	17.4
	18" (450mm) Pole	EZP1P18	75620	20.3
	24" (600mm) Pole	EZP1P24	75621	22.7
	30" (750mm) Pole	EZP1P30	75622	26.5
	36" (900mm) Pole	EZP1P36	75623	30.4
	42" (1050mm) Pole	EZP1P42	75624	32.7
	48" (1200mm) Pole	EZP1P48	75625	35.3
	54" (1350mm) Pole	EZP1P54	75626	39.2
	60" (1500mm) Pole	EZP1P60	75627	43.3
	72" (1800mm) Pole	EZP1P72	75772	48.2
2	Torsion Mounting Plate Kit* (2 ea.)	EZPTMPK	78507	8.7
3	Torsion Cap Kit* (1 ea.) (includes 1 ea. Item 4)	EZPTCK	78508	3.2
3a	Torsion Cap Kit HD* (1 ea.) (includes 1 ea. Item 4)	EZPTCKHD	78509	3.2
4	Torsion Shield	EZPTSR	78510	.1
5	Torsion Spring Kit	EZPTSK	78511	6.0
5a	Torsion Spring Kit HD	EZPTSKHD	78512	8.5
6	Pole Lock* (1 ea.)	EZP1PL	75641	1.1
-	Torsion Bar Tensioner for blade widths 12" - 48" (300 - 1200mm) (includes 1 each items 3, 4, & 5)	EZPTBT	77384	17.4
-	Torsion Bar Tensioner HD for blade widths 54" - 72" (1350 - 1800mm) (includes 1 each items 3a, 4, & 5a)	EZPTBTHD	77385	20.0
7	Blade Pin (1 ea.)	EZP1BP	75642	0.1

*Hardware Included Lead time: 1 working day

Replacement Conshear™ Blades

Ref	Blade Width		Ordering Number	Item Code	Wt. Lbs.
	in.	mm			
8	10	250	CRB10	75628	4.6
	16	400	CRB16	75629	7.3
	22	550	CRB22	75630	10.1
	28	700	CRB28	75631	12.8
	34	850	CRB34	75632	15.5
	40	1000	CRB40	75633	18.3
	46	1150	CRB46	75634	21.0
	52	1300	CRB52	75635	23.8
	58	1450	CRB58	75636	26.5
	64	1600	CRB64	75775	29.2
	70	1750	CRB70	75773	32.0

Order blade width for your belt width's material path: Belt Width Minus 2", Belt Width Minus 8" or Belt Width Minus 14".

Lead time: 1 working day

Optional Replacement High Temp Conshear™ Blades
(Color Identification: Yellow)

Blade Width		Ordering Number	Item Code	Wt. Lbs.
in.	mm			
10	250	CRB-HT10	76593	4.8
16	400	CRB-HT16	76594	7.6
22	550	CRB-HT22	76595	10.4
28	700	CRB-HT28	76596	13.2
34	850	CRB-HT34	76597	16.2
40	1000	CRB-HT40	76598	19.1
46	1150	CRB-HT46	76599	21.9
52	1300	CRB-HT52	76600	24.8
58	1450	CRB-HT58	76601	27.6
64	1600	CRB-HT64	76602	30.5
70	1750	CRB-HT70	76603	33.4

Lead time: 1 working day

U.S. Patent No. D482,508S



Section 10 – Other Flexco Conveyor Products

Flexco provides many conveyor products that help your conveyors to run more efficiently and safely. These components solve typical conveyor problems and improve productivity. Here is a quick overview on just a few of them:

MSP Precleaner



- Patented ConShear™ blade renews its cleaning edge as it wears
- Visual Tension Check™ for optimal blade tensioning and simple retensioning
- Quick and easy one-pin blade replacement Material Path Option™ for optimal cleaning and reduced maintenance

DRX Impact Beds



- Exclusive Velocity Reduction Technology™ to better protect the belt
- Slide-Out Service™ gives direct access to all impact bars for change-out
- Impact bar supports for longer bar life
- 4 models to custom fit to the application

EZS2 Secondary Cleaner



- Long-wearing tungsten carbide blades for superior cleaning efficiency
- Patented FormFlex™ cushions independently tension each blade to the belt for consistent, constant cleaning power
- Easy to install, simple to service
- Works with Flexco mechanical belt splices

PT Max™ Belt Trainer



- Patented “pivot & tilt” design for superior training action
- Dual sensor rollers on each side to minimize belt damage
- Pivot point guaranteed not to seize or freeze up
- Available for topside and return side belts

Flexco Specialty Belt Cleaners



- “Limited space” cleaners for tight conveyor applications
- High Temp cleaners for severe, high heat applications
- A rubber fingered cleaner for chevron and raised rib belts
- Multiple cleaner styles in stainless steel for corrosive applications

Belt Plows



- A belt cleaner for the tail pulley
- Exclusive blade design quickly spirals debris off the belt
- Economical and easy to service
- Available in vee or diagonal models



2525 Wisconsin Avenue • Downers Grove, IL 60515-4200 • USA
Tel: (800) 541-8028 • Fax: (630) 971-1180 • E-mail: info@flexco.com

Visit www.flexco.com for other Flexco locations and products.

©2021 Flexible Steel Lacing Company. 03/22/21. For reorder: X2460

