

MSP Precleaner

Installation, Operation and Maintenance Manual



MSP Precleaner

Serial Number: _____

Purchase Date: _____

Purchased From: _____

Installation Date: _____

Serial number information can be found on the Serial Number Label included in the Information Packet found in the cleaner carton.

This information will be helpful for any future inquiries or questions about belt cleaner replacement parts, specifications or troubleshooting.

Table of Contents

Section 1 - Important Information	4
1.1 General Introduction	4
1.2 User Benefits	4
1.3 Service Option	4
Section 2 - Safety Considerations and Precautions	5
2.1 Stationary Conveyors	5
2.2 Operating Conveyors	5
Section 3 - Pre-Installation Checks and Options	6
3.1 Checklist	6
3.2 Cleaner Location Adjustments	7
3.3 Optional Installation Accessories	8
3.4 Correct Blade Installation and Tensioning	9
Section 4 - Installation Instructions	10
Section 5 - Pre-Operation Checklist and Testing	13
5.1 Pre-Op Checklist	13
5.2 Test Run the Conveyor	13
Section 6 - Maintenance	14
6.1 New Installation Inspection	14
6.2 Routine Visual Inspection	14
6.3 Routine Physical Inspection	14
6.4 Blade Replacement Instructions	15
6.5 Maintenance Log	17
6.6 Cleaner Maintenance Checklist	18
Section 7 - Troubleshooting	19
Section 8 - Specs and CAD Drawing	20
8.1 Specs and Guidelines	20
8.2 CAD Drawing	21
Section 9 - Replacement Parts	22
Section 10 - Other Flexco Conveyor Products	23

Section 1 - Important Information

1.1 General Introduction

We at Flexco are very pleased that you have selected a Flexco precleaner for your conveyor system.

This manual will help you to understand the operation of this product and assist you in making it work up to its maximum efficiency over its lifetime of service.

It is essential for safe and efficient operation that the information and guidelines presented be properly understood and implemented. This manual will provide safety precautions, installation instructions, maintenance procedures and troubleshooting tips.

If, however, you have any questions or problems that are not covered, please visit our web site or contact our Customer Service Department:

Customer Service: 49-7428-9406-0

Visit www.flexco.com for other Flexco locations and products.

Please read this manual thoroughly and pass it on to any others who will be directly responsible for installation, operation and maintenance of this cleaner. While we have tried to make the installation and service tasks as easy and simple as possible, it does however require correct installation and regular inspections and adjustments to maintain top working condition.

1.2 User Benefits

Correct installation and regular maintenance will provide the following benefits for your operation:

- Reduced conveyor downtime
- Reduced man-hour labor
- Lower maintenance budget costs
- Increased service life for the belt cleaner and other conveyor components

1.3 Service Option

The MSP Precleaner is designed to be easily installed and serviced by your on-site personnel. However, if you would prefer complete turn-key factory service, please contact your local Flexco Field Engineer or your Flexco Distributor.

Section 2 - Safety Considerations and Precautions

Before installing and operating the MSP Precleaner, it is important to review and understand the following safety information.

There are set-up, maintenance and operational activities involving both stationary and operating conveyors. Each case has a safety protocol.

2.1 Stationary Conveyors

The following activities are performed on stationary conveyors:

- Installation
- Blade replacement
- Repairs
- Tension adjustments
- Cleaning

DANGER

It is imperative that OSHA/MSHA Lockout/Tagout (LOTO) regulations, 29 CFR 1910.147, be followed before undertaking the preceding activities. Failure to use LOTO exposes workers to uncontrolled behavior of the belt cleaner caused by movement of the conveyor belt. Severe injury or death can result.

Before working:

- Lockout/Tagout the conveyor power source
- Disengage any takeups
- Clear the conveyor belt or clamp securely in place

WARNING

Use Personal Protective Equipment (PPE):

- Safety eyewear
- Hardhats
- Safety footwear

Close quarters, springs and heavy components create a worksite that compromises a worker's eyes, feet and skull. PPE must be worn to control the foreseeable hazards associated with conveyor belt cleaners. Serious injuries can be avoided.

2.2 Operating Conveyors

There are two routine tasks that must be performed while the conveyor is running:

- Inspection of the cleaning performance
- Dynamic troubleshooting

DANGER

Every belt cleaner is an in-running nip hazard. Never touch or prod an operating cleaner. Cleaner hazards cause instantaneous amputation and entrapment.

WARNING

Conveyor chutes contain projectile hazards. Stay as far from the cleaner as practical and use safety eyewear and headgear. Missiles can inflict serious injury.

WARNING

Never adjust anything on an operating cleaner. Unforseeable belt projections and tears can catch on cleaners and cause violent movements of the cleaner structure. Flailing hardware can cause serious injury or death.

Section 3 - Pre-installation Checks and Options

3.1 Checklist

- Check that the cleaner size is correct for the beltline width
- Check the belt cleaner carton and make sure all the parts are included
- Review the “Tools Needed” list on the top of the installation instructions
- Check the conveyor site:
 - Will the cleaner be installed on a chute
 - Is the install on an open head pulley requiring mounting structure (see 3.3 - Optional Installation Accessories)
 - Are there obstructions that may require cleaner location adjustments (see 3.2 - Cleaner Location Adjustments)

Section 3 - Pre-installation Checks and Options (cont.)

3.2 Cleaner Location Adjustments

In certain applications it is necessary to modify the location of the precleaner pole due to permanent obstacles that obstruct the desired location. Relocating the pole location can be done easily and does not hinder the performance of the cleaner as long as the “C” dimension is maintained.

NOTE: In the following example we will be lowering the pole location in the “Y” direction, but the same method could also be applied in the “X” direction.

Conveyor situation:

Pulley Diameter: 450mm

X = 204mm

Y = 230mm

C = 308mm

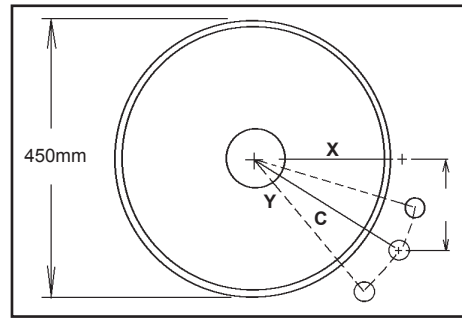

- Determine the given location dimensions and define the change needed.** After laying out the given X & Y dimensions, determine the distance of the modification required for adequate clearance of the pole and tensioning system. (In the example we decide to lower the pole 51mm to clear the support structure).
- Write down known dimensions.** We can now determine two of the three required dimension which will allow us to find the third. We know we cannot alter the “C” dimension, so this will remain the same. Also we are required to lower the unit in the “Y” dimension 51mm, so we add 51mm to the given “Y” dimension.

X = ?

Y = 230 + 51 = 281mm

C = 308mm

- Determine final dimension.** On a flat vertical surface, using a level, draw one horizontal line and one vertical line creating a right triangle (Fig 3a). Measure down from the intersection the determined “Y” dimension and mark (Fig 3b). With the tape measure starting at the modified “Y” mark, swing the tape across the “X” line and mark at the “C” dimension where it crosses the “X” line (Fig 3c). Measure from the intersection to the “C” intersection and this will be your new “X” dimension (Fig. 3d).

X = 259mm

Y = 281mm

C = 308mm

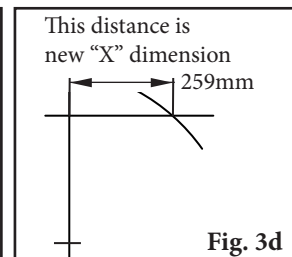
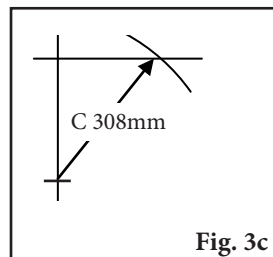
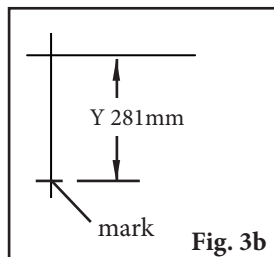
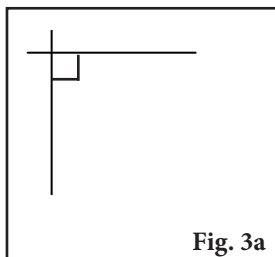

Section 3 - Pre-Installation Checks and Options (cont.)

3.3 Optional Installation Accessories

Versatile, adjustable brackets and plates that can be mounted on the conveyor structure so precleaners and secondary cleaners can be easily and quickly bolted into place.

- 75830**
Optional Mounting Bar Kit
 (with bolts, nuts and washers)
- For mounting precleaners on open head pulleys.
 - Weld on both sides of pulley and bolt on steel plates.
 - 38mm W x 406mm L with (4) 279mm tapped holes

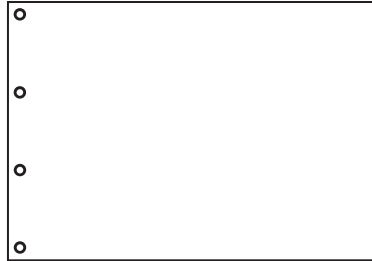

- 76537**
Mounting Plate Kit (incl. 2 plates)
- For use with Mounting Bars to mount cleaners on open head pulleys.
 - 400 x 800mm with (4) 16mm holes

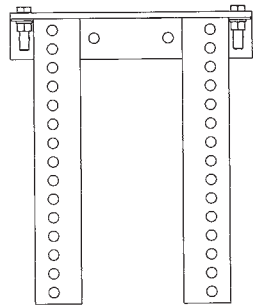

- 76071**
Standard Mounting Bracket Kit
- For most secondary cleaner installs.
 - 330mm W x 394mm L

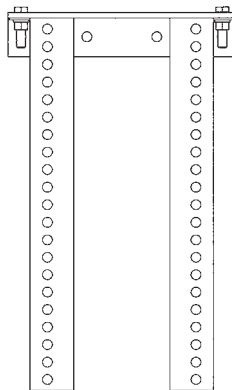

- 76072**
Long Mounting Bracket Kit
- For installations that require extra length legs.
 - 330mm W x 546mm L

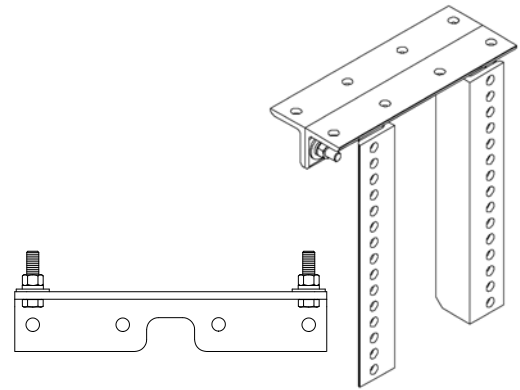

- 76073**
Optional Top Angle Kit
- Used with both standard and long mounting bracket kits for additional mounting options.
 - 330mm L

Optional Mounting Kits (incl. 2 brackets/bars)

Description	Ordering Number	Item Code	WT. Kg.
Standard Mounting Bracket Kit *	SSTSMB	76071	15.6
Long Mounting Bracket Kit *	SSTLMB	76072	19.7
Optional Top Angle Kit *	SSTOTA	76073	4.8
Optional Mounting Bar Kit *	MMBK	75830	8.4
Mounting Plate Kit (incl. 2 plates)	MMPK	76537	63.5

*Hardware Included
 Lead time: 1 working day

Pole Extender Kit (incl. 2 extenders)

Description	Ordering Number	Item Code	WT. Kg.
Pole Extender Kit	MAPEK	76024	9.9

Provides 750mm of extended pole length.
 Lead time: 1 working day

Specs and Notes:

- Standard brackets are 13"W x 15 1/2"L.
- Long brackets are 13"W x 21-1/2"L.
- Mounting bars are 1-1/2"W x 16" L with (4) 5/8-11 tapped holes.
- Mounting plates are 16"W x 32"L with (4) 5/8 holes.

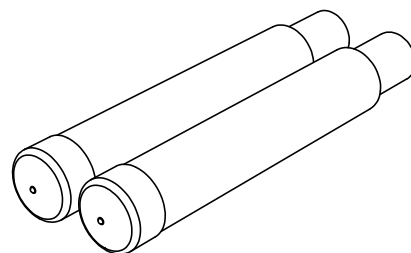

Section 3 - Pre-Installation Checks and Options (cont.)

3.4 Correct Blade Installation and Tensioning

For optimal cleaning efficiency and long wear life, the ConShear™ blade must be located and tensioned correctly on the belt head pulley. If the cleaner pole is in the wrong location the performance of the new blade may be adversely affected. See “Possible Problems” below. For tensioning, please follow these instructions.

Correct Location:

When blade contact is made against the head pulley (prior to tensioning) there should be a 1mm to 3mm gap at the bottom of the blade face (Fig. 1).

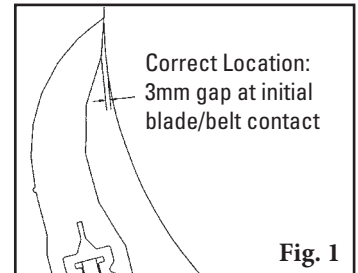

Possible Problems:

- Pole location too far out - The initial blade/belt contact gap will be larger than 3mm (Fig. 2). If the blade is correctly tensioned it may flip through before it is fully worn. If tensioned too lightly, it will develop the “smile effect” quickly and not clean properly.
- Pole location too far in - If there is no gap at the initial blade/belt contact (Fig. 3), the tip of the blade may not be touching the belt. In this case, the blade will push away and lose its shearing (cleaning) effect. The blade may also develop a flap at the tip which may trap material.

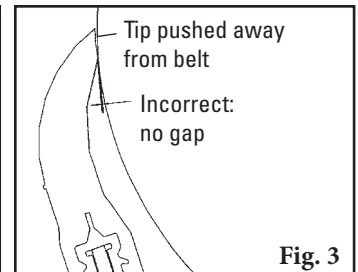
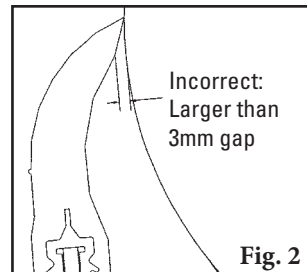

Correct Tensioning:

The blade should be tensioned until the gap is gone (Fig. 4).

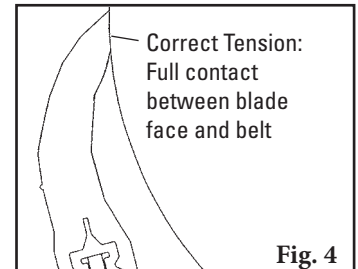

The “Material Path” Option

For optimal cleaning and reduced blade retensioning, the cleaner blade width should be sized to fit the material path of the belt. The material path is typically the center 2/3 of the belt width. Choosing a blade only slightly wider than the material path can decrease differential blade wear which reduces blade retensioning maintenance, as well as reducing the frequency of blade replacement.

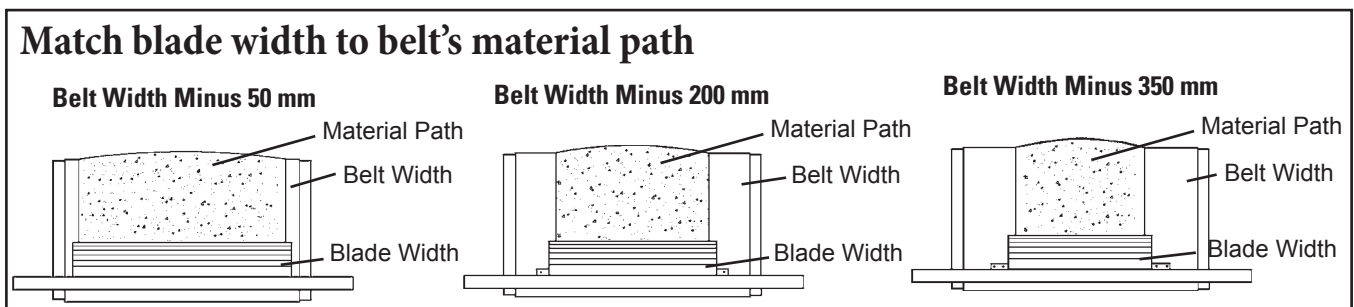

Section 4 - Installation Instructions

4.1 MSP Precleaner

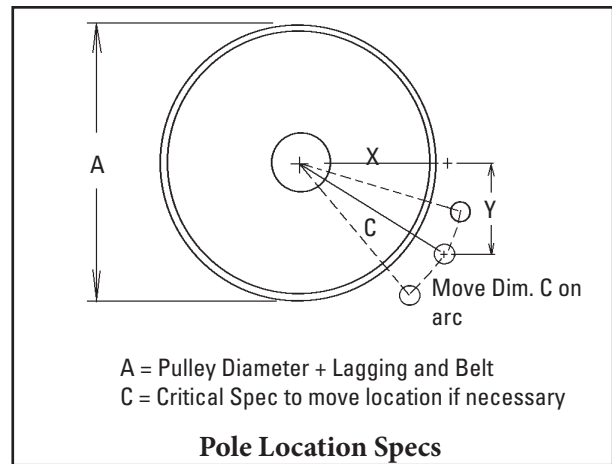
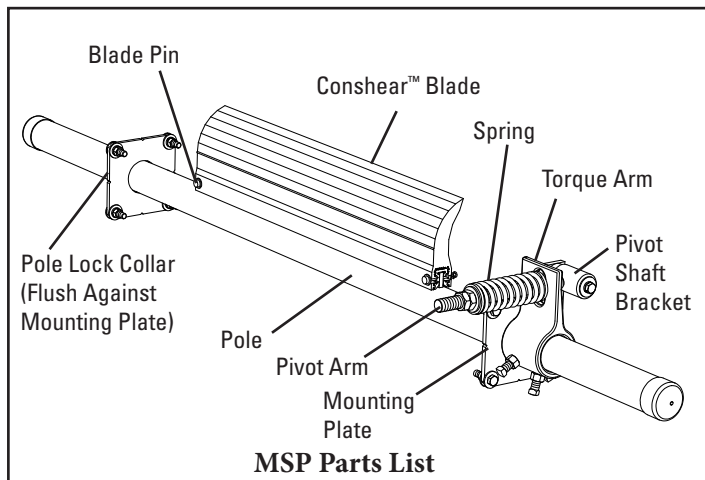

Physically lock out and tag the conveyor at the power source before you begin cleaner installation.

Tools Needed:

- 14mm (9/16") Wrench
- 16mm (5/8") Wrench
- 19mm (3/4") Wrench
- 24mm (15/16") Wrench
- 35mm (1-3/8") Wrench
- Torch (as needed)
- Welder (as needed)
- Tape Measure
- Level
- Marking Pen or Soapstone

OR

Large Adjustable/Crescent Wrenches (x2)

1. Locate the correct pole position. Measure and determine Dimension A (see instructions above). Find Dimension A on the Pole Location Chart at right and determine Dimensions X, Y and C. Measure out horizontally from the center of the pulley shaft Dim X and mark. From that mark, draw a long vertical line down, then measure and mark Dim Y. This indicates the location of the center of the cleaner pole. Measure and mark both sides. **NOTE:** If the location is obstructed, use Dim. C and move on an arc from the center of the pulley shaft to find an open position. Dim. C must remain constant to correctly locate the pole (see drawing above). **NOTE:** For open head installs, first add mounting support materials to the structure.

2. Mark and cut the mounting plate holes. Using the mounting plate template provided in the instruction packet, position the large pole access hole on the chute, aligning the hole notches with the layout lines. Position the keyway toward the pulley. Trace the pole cutout and mounting holes (Fig. 2). Cut the holes on both sides of the chute. **NOTE:** Hole cutouts are slotted for later adjustment if needed.

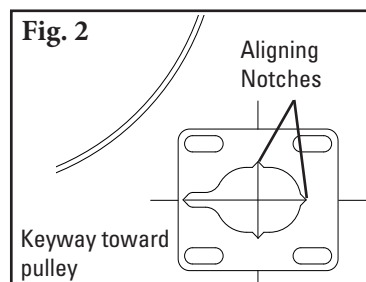

Pole Location Chart

A	X	Y	C
250	68	230	240
275	88	230	246
300	102	230	252
325	130	230	264
350	142	230	270
375	164	230	282
400	176	230	290
425	196	230	302
450	204	230	308
475	222	230	320
500	232	230	326
525	248	230	338
550	266	230	352
575	282	230	364
600	298	230	376
625	312	230	388
650	330	230	402
675	344	230	414
700	358	230	426
725	372	230	438
750	390	230	452
775	402	230	464
800	416	230	476
825	430	230	488
850	446	230	502
875	460	230	514
900	474	230	526
925	486	230	538
950	502	230	552
975	514	230	564
1000	528	230	576
1025	542	230	588
1050	556	230	602

Section 4 - Installation Instructions

4.1 MSP Precleaner (cont.)

3. **Install the mounting plates.** Bolt the mounting plates to the chute with bolts provided. Center plates on the slotted holes and tighten bolts (Fig. 3).

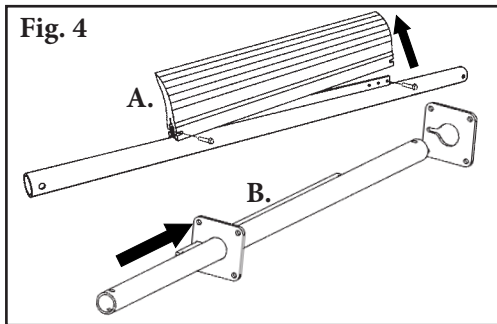
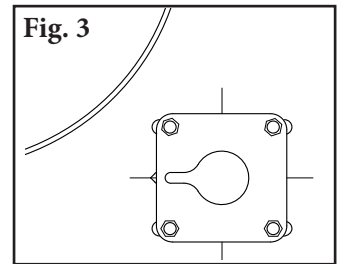

4. **Install the pole.** Remove both blade pins and blade from the pole and insert the pole in through the mounting plates (Fig. 4).

5. **Center the cleaner on the belt and lock in place.** Reinstall the blade with both blade pins. Center the blade on the belt and install the pole lock collar onto the pole (on the end opposite the end to be used for the tensioner), snugly up to the mounting plate (Fig. 5a). Rotate the blade up to the belt and check to insure that the blade is square to the pulley face. If not, loosen a mounting plate on one side and adjust the plate forward or backward to square the blade to the pulley, and retighten the bolts (Fig. 5b).

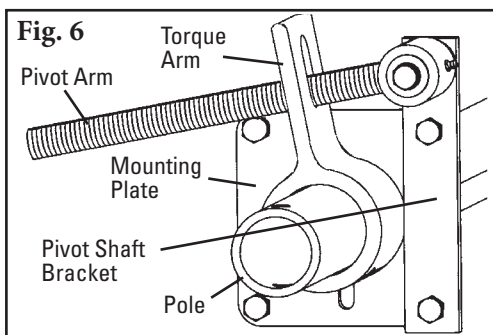
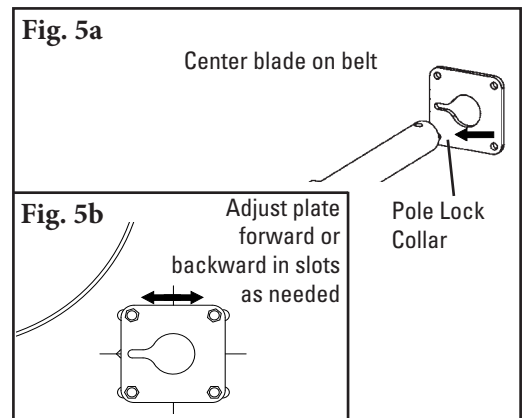

6. **Install the QMT spring tensioner.** Remove the adjusting nuts and springs from the pivot rod. Insert the pivot arm through the slot in the torque arm. Slide the torque arm onto the pole end (be sure the rotation of the arm is correct to tension the blade) and rotate it until the pivot shaft bracket lines up with the desired bolt holes (Fig. 6). Remove bolts, nuts and washers from mounting plate and reinstall through pivot shaft bracket and mounting plate.

7. **Reassemble the spring assembly.** Slide the spring, washer and bushings onto the pivot arm and turn the two adjusting nuts so about 6mm of the pivot arm is exposed above the nuts (Fig. 7).

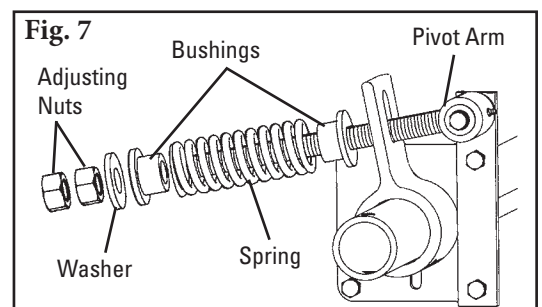

Section 4 - Installation Instructions

4.1 MSP Precleaner (cont.)

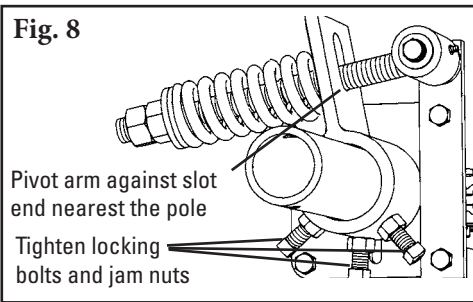

8. **Tension the blade to the belt.** Rotate the blade until it contacts the belt. While holding the spring bushing flat on the torque arm, rotate the torque arm until the pivot arm is against the end of the slot nearest the pole. Tighten the locking bolts and jam nuts on the torque arm (Fig. 8). **NOTE:** The torque arm should be up against the mounting plate.

9. **Set the correct blade tension.** Refer to the chart on the pivot shaft bracket for the spring length required for the blade width. Lightly pull the pivot arm toward the end of the torque arm slot nearest the pole and turn the adjusting nuts until the required spring length is achieved (Fig. 9). Tighten jam nut.

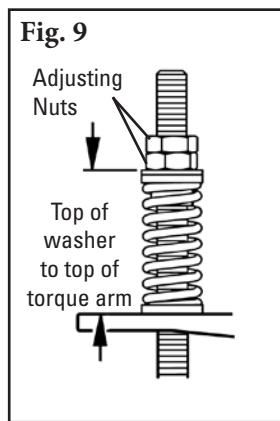

Blade Width	Purple Spring	White Spring	Gold Spring
450mm	131mm	159mm	N/A
600mm	121mm	156mm	N/A
750mm	105mm	149mm	N/A
800mm	N/A	146mm	156mm
950mm	N/A	143mm	156mm
1000mm	N/A	140mm	152mm
1150mm	N/A	137mm	149mm
1200mm	N/A	130mm	149mm
1350mm	N/A	127mm	146mm
1400mm	N/A	124mm	143mm
1550mm	N/A	N/A	143mm
1600mm	N/A	N/A	140mm
1750mm	N/A	N/A	131mm
1800mm	N/A	N/A	130mm
1950mm	N/A	N/A	130mm
2100mm	N/A	N/A	127mm

Shading indicates preferred spring option.

10. **Confirm correct pole location.** After the cleaner is installed, slide the Pole Location Gauge (provided in the instruction packet) between the cleaner pole and the pulley, until it stops at a step (Fig. 8a). Read the flat area where the pole is resting (Fig. 8b). This diameter should be equal to Dim A used in Step 1. **NOTE:** If the diameter reading on the Pole Location Gauge does not read the same as in Step 1, check the “C” dimension and correct accordingly.

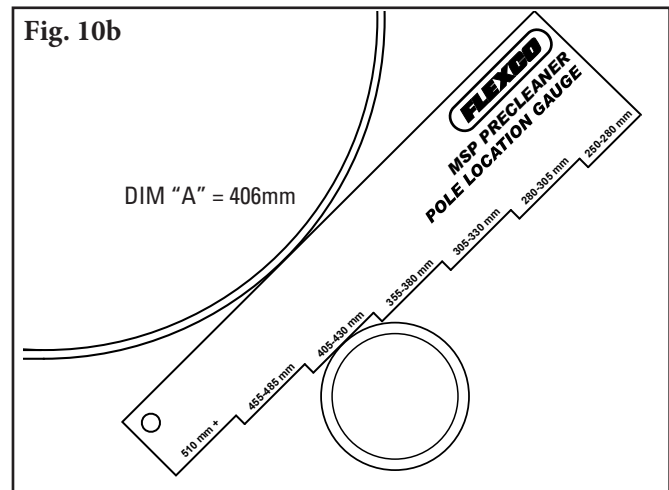
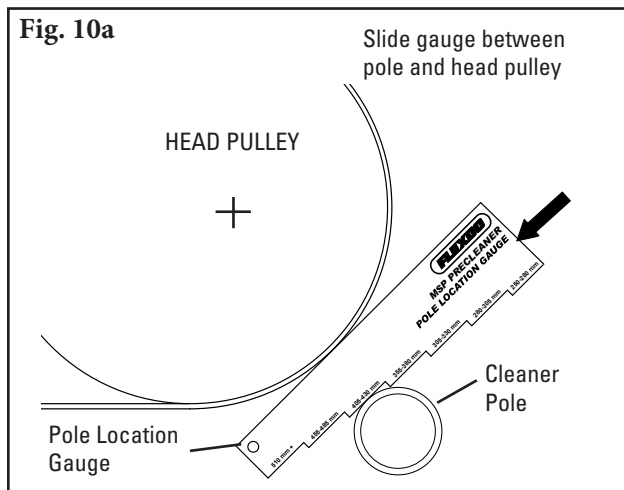

Test run the cleaner. Run the conveyor for at least 15 minutes and inspect the cleaning performance. Check the spring length for proper tensioning. Make adjustments as necessary.

Section 5 - Pre-Operation Checklist and Testing

5.1 Pre-Op Checklist

- Recheck that all fasteners are tightened properly
- Add pole caps
- Apply all supplied labels to the cleaner
- Check the blade location on the belt
- Be sure that all installation materials and tools have been removed from the belt and the conveyor area

5.2 Test Run the Conveyor

- Run the conveyor for at least 15 minutes and inspect the cleaning performance
- Check the tensioner spring for recommended length (proper tensioning)
- Make adjustments as necessary

NOTE: Observing the cleaner when it is running and performing properly will help to detect problems or when adjustments are needed later.

Section 6 - Maintenance

Flexco belt cleaners are designed to operate with minimum maintenance. However, to maintain superior performance some service is required. When the cleaner is installed a regular maintenance program should be set up. This program will ensure that the cleaner operates at optimal efficiency and problems can be identified and fixed before the cleaner stops working.

All safety procedures for inspection of equipment (stationary or operating) must be observed. The MSP Precleaner operates at the discharge end of the conveyor and is in direct contact with the moving belt. Only visual observations can be made while the belt is running. Service tasks can be done only with the conveyor stopped and by observing the correct lockout/tagout procedures.

6.1 New Installation Inspection

After the new cleaner has run for a few days a visual inspection should be made to ensure the cleaner is performing properly. Make adjustments as needed.

6.2 Routine Visual Inspection (every 2-4 weeks)

A visual inspection of the cleaner and belt can determine:

- If the spring length is the correct length for optimal tensioning
- If the belt looks clean or if there are areas that are dirty
- If the blade is worn out and needs to be replaced
- If there is damage to the blade or other cleaner components
- If fugitive material is built up on the cleaner or in the transfer area
- If there is cover damage to the belt
- If there is vibration or bouncing of the cleaner on the belt
- If a snub pulley is used, a check should be made for material buildup on the pulley

If any of the above conditions exist, a determination should be made on when the conveyor can be stopped for cleaner maintenance.

6.3 Routine Physical Inspection (every 6-8 weeks)

When the conveyor is not in operation and properly locked and tagged out a physical inspection of the cleaner to perform the following tasks:

- Clean material buildup off the cleaner blade and pole.
- Closely inspect the blade for wear and any damage. Replace if needed.
- Check both blade pins and retaining clips for proper installation and condition. Replace if needed.
- Ensure full blade to belt contact.
- Inspect the cleaner pole for damage.
- Inspect all fasteners for tightness and wear. Tighten or replace as needed.
- Replace any worn or damaged components.
- Check the tension of the cleaner blade to the belt. Adjust the tension if necessary using the chart on the cleaner or the one on page 12.
- When maintenance tasks are completed, test run the conveyor to ensure the cleaner is performing properly.

Section 6 - Maintenance

6.4 Blade Replacement Instructions

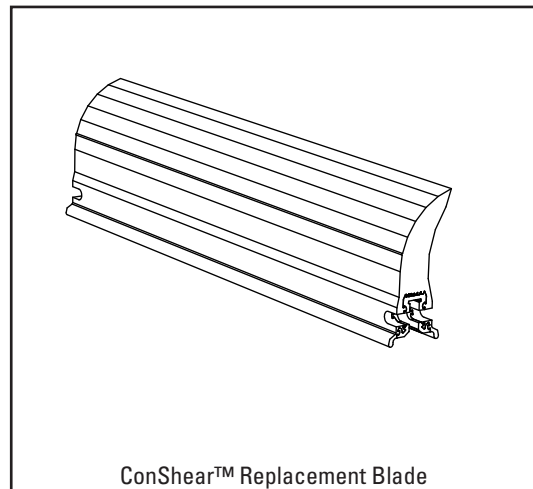
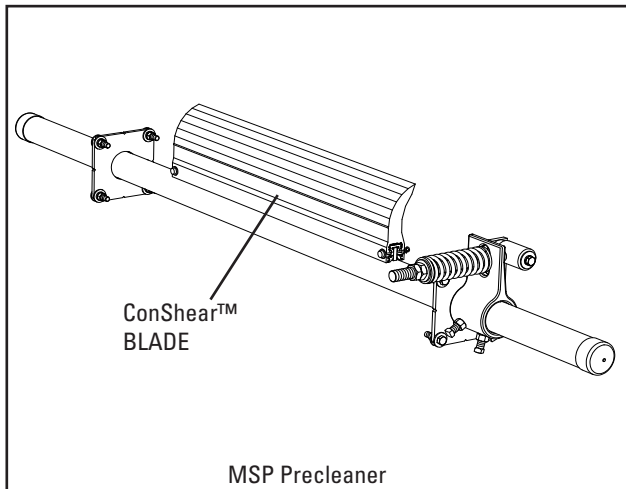

Physically lock out and tag the conveyor at the power source before you begin cleaner installation.

Tools Needed:

- Tape measure
- (2) 21mm wrenches or crescent wrenches
- Wire brush (for cleaning pole)
- Small putty knife (for cleaning pole)

1. **Remove the tension.** Loosen the adjusting nuts and turn them out until they are flush with the pivot arm (Fig. 1). This releases the tension of the blade on the belt.

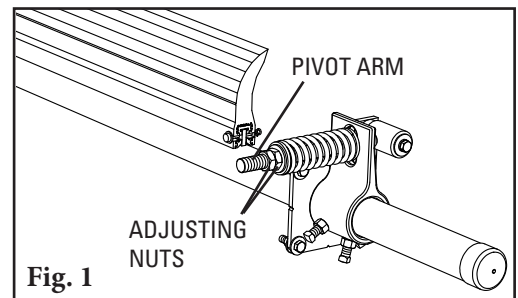

2. **Remove the worn blade.** Remove one blade pin and remove the blade from the pole (Fig. 2). Clean all fugitive material from the pole.

NOTE: If blade is hard to remove use a screwdriver or hammer to loosen it and then remove.

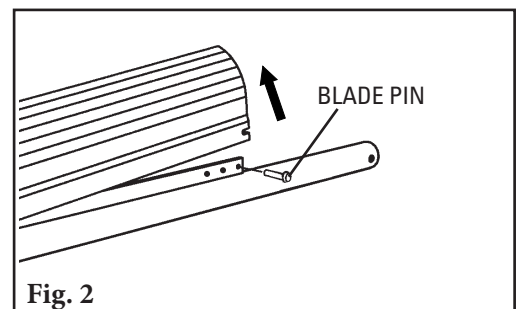

Section 6 - Maintenance

6.4 Blade Replacement Instructions

3. **Install the new blade.** Slide the new blade onto the pole, locking it into the far blade pin, then reinstall the removed blade pin, washer and clip (Fig. 3).

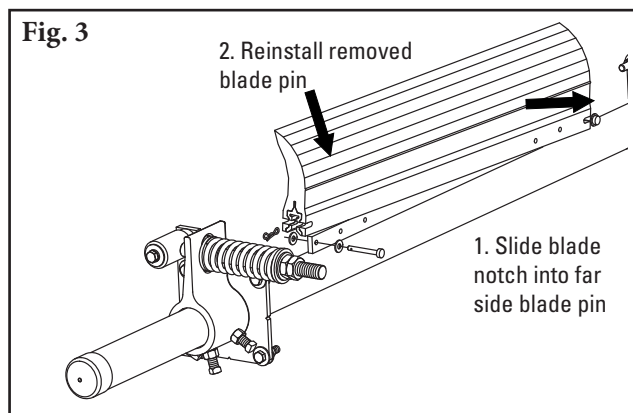

4. **Reset the correct blade tension.** Refer to the chart for the spring length required for the blade width. Lightly pull the pivot arm toward the end of the torque arm slot nearest the pole and turn the adjusting nut until the required spring length is achieved (Fig. 4). Tighten jam nut.

NOTE: The chart is also on the cleaner's pivot shaft bracket for future reference for retensioning maintenance.

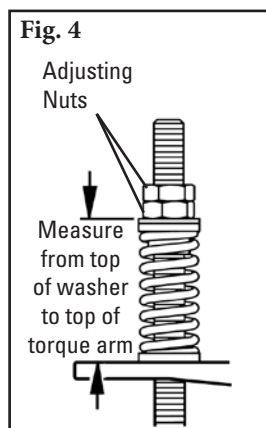

Spring Length Chart			
Blade Width	Purple Spring	White Spring	Gold Spring
450mm	131mm	159mm	N/A
600mm	121mm	156mm	N/A
750mm	105mm	149mm	N/A
800mm	N/A	146mm	156mm
950mm	N/A	143mm	156mm
1000mm	N/A	140mm	152mm
1150mm	N/A	137mm	149mm
1200mm	N/A	130mm	149mm
1350mm	N/A	127mm	146mm
1400mm	N/A	124mm	143mm
1550mm	N/A	N/A	143mm
1600mm	N/A	N/A	140mm
1750mm	N/A	N/A	131mm
1800mm	N/A	N/A	130mm
1950mm	N/A	N/A	130mm
2100mm			127mm

Shading indicates preferred spring option.

Test run the cleaner. Run the conveyor for at least 15 minutes and inspect the cleaning performance. Check the spring length for proper tensioning. Make adjustments as necessary.

Section 6 - Maintenance

6.5 Maintenance Log

Conveyor Name/No. _____

Date: _____ Work done by: _____ Service Quote #: _____

Activity: _____

Date: _____ Work done by: _____ Service Quote #: _____

Activity: _____

Date: _____ Work done by: _____ Service Quote #: _____

Activity: _____

Date: _____ Work done by: _____ Service Quote #: _____

Activity: _____

Date: _____ Work done by: _____ Service Quote #: _____

Activity: _____

Date: _____ Work done by: _____ Service Quote #: _____

Activity: _____

Date: _____ Work done by: _____ Service Quote #: _____

Activity: _____

Date: _____ Work done by: _____ Service Quote #: _____

Activity: _____

Section 6 - Maintenance

6.6 Cleaner Maintenance Checklist

Site: _____ Inspected by: _____ Date: _____

Belt Cleaner: _____ Serial Number: _____

Blade Width: Belt minus 50mm Belt minus 200mm Belt minus 350mm

Beltline Information:

Beltline Number: _____ Belt Condition: _____

Belt Width: 600mm (24") 750mm (30") 900mm (36") 1050mm (42") 1200mm (48") 1350mm (54") 1500mm (60") 1800mm (72") 2100mm (84")

Head Pulley Diameter (Belt & Lagging): _____ Belt Speed: _____ m/s Belt Thickness: _____

Belt Splice: _____ Condition of Splice: _____ Number of Splices: _____ Skived Unskived

Material conveyed: _____

Days per week run: _____ Hours per day run: _____

Blade Life:

Date blade installed: _____ Date blade inspected: _____ Estimated blade life: _____

Is blade making complete contact with belt? Yes No

Distance from wear line: Left _____ Middle _____ Right _____

Blade condition: Good Grooved Smiled Not contacting belt Damaged

Measurement of spring: Required _____ Currently _____

Was Cleaner Adjusted: Yes No

Pole Condition: Good Bent Worn

Lagging: Side Lag Ceramic Rubber Other None

Condition of lagging: Good Bad Other _____

Cleaner's Overall Performance: (Rate the following 1 - 5, 1= very poor - 5 = very good)

Appearance: Comments: _____

Location: Comments: _____

Maintenance: Comments: _____

Performance: Comments: _____

Other comments: _____

Section 7 - Troubleshooting

Problem	Possible Cause	Possible Solutions
Poor Cleaning Performance	Cleaner under - tensioned	Adjust to correct tension - see chart
	Cleaner over - tensioned	Adjust to correct tension - see chart
	Cleaner installed in wrong location	Verify "C" dimension, relocate to correct dimension
	Cleaner blade worn or damaged	Replace cleaner blade
Rapid Blade Wear	Tension on cleaner too high/low	Adjust to correct tension - see chart
	Cleaner not located correctly	Check cleaner location for correct dimensions
	Blade attack angle incorrect	Check cleaner location for correct dimensions
	Material too abrasive for blade	Option: if vulcanized belt, switch to alternate cleaner with metal blades
	Mechanical splice damaging blade	Repair, skive or replace splice
Center wear on blade (smile effect)	Blade wider than material path	Replace blade with width to match material path
	Tension on cleaner too high/low	Adjust to correct tension - see chart
Unusual wear or damage to blade	Mechanical splice damaging blade	Repair, skive or replace splice
	Belt damaged or ripped	Repair or replace belt
	Cleaner not correctly located	Verify "C" dimension, relocate to correct dimension
	Damage to pulley or pulley lagging	Repair or replace pulley
Vibration or noise	Cleaner not located correctly	Verify "C" dimension, relocate to correct dimension
	Blade attack angle incorrect	Verify "C" dimension, relocate to correct dimension
	Cleaner running on empty belt (dry)	Use a spray pole when the belt is empty
	Cleaner tension too high/low	Adjust to correct tension or slight adjust to diminish
	Cleaner locking bolts not secure	Check and tighten all bolts and nuts
	Cleaner not square to head pulley	Verify "C" dimension, relocate to correct dimension
	Material buildup in chute	Clean up build-up on cleaner and in chute
Cleaner being pushed away from pulley	Cleaner tension not set correctly	Ensure correct tension/increase tension slightly
	Sticky material is overburdening cleaner	Increase tension; replace with cleaner with metal tips; replace with larger size cleaner
	Cleaner not set up correctly	Confirm location dimensions are equal on both sides
	Pole too far out ("C" dimension too large)	Verify "C" dimension, relocate to correct dimension

Section 8 - Specs and CAD Drawing

8.1 Specs and Guidelines

Pole Length Specifications*

Cleaner Size	Pole Length	Maximum Conveyor Span
mm	mm	mm
650	2133	1883
800	2286	2036
1000	2438	2188
1200	2590	2340
1400	2895	2645
1600	3054	2804
1800	3206	2956
2000	3511	3261

*For special extra long pole length requirements a Pole Extender Kit (#76024) is available that provides 750mm of extended pole length.
Pole Diameter - 73mm

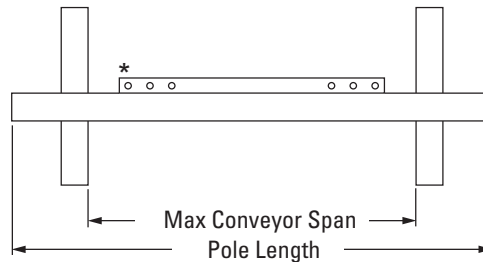

*Each pole size can be used with a blade size either belt width minus 50mm, belt width minus 200mm, or belt width minus 350mm.

Clearance Guidelines for Installation

Horizontal Clearance Required	Vertical Clearance Required
mm	mm
100	250

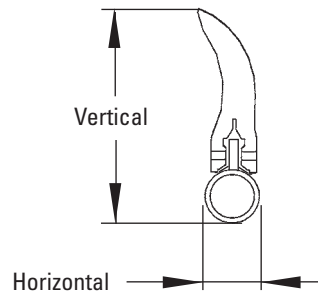

Pole Location Specs

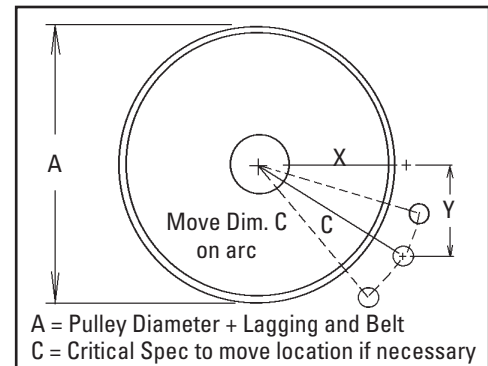

A = Pulley Diameter + Lagging and Belt
C = Critical Spec to move location if necessary

Spring Length Chart

Blade Width	Purple Spring	White Spring	Gold Spring
450mm	131mm	159mm	N/A
600mm	121mm	156mm	N/A
750mm	105mm	149mm	N/A
800mm	N/A	146mm	156mm
950mm	N/A	143mm	156mm
1000mm	N/A	140mm	152mm
1150mm	N/A	137mm	149mm
1200mm	N/A	130mm	149mm
1350mm	N/A	127mm	146mm
1400mm	N/A	124mm	143mm
1550mm	N/A	N/A	143mm
1600mm	N/A	N/A	140mm
1750mm	N/A	N/A	131mm
1800mm	N/A	N/A	130mm
1950mm	N/A	N/A	130mm
2100mm			127mm

Shading indicates preferred spring option.

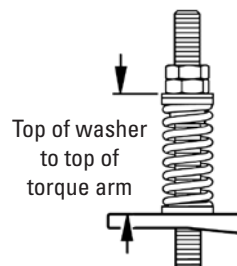

Pole Location Chart

A	X	Y	C
250	68	230	240
275	88	230	246
300	102	230	252
325	130	230	264
350	142	230	270
375	164	230	282
400	176	230	290
425	196	230	302
450	204	230	308
475	222	230	320
500	232	230	326
525	248	230	338
550	266	230	352
575	282	230	364
600	298	230	376
625	312	230	388
650	330	230	402
675	344	230	414
700	358	230	426
725	372	230	438
750	390	230	452
775	402	230	464
800	416	230	476
825	430	230	488
850	446	230	502
875	460	230	514
900	474	230	526
925	486	230	538
950	502	230	552
975	514	230	564
1000	528	230	576
1025	542	230	588
1050	556	230	602

Specifications:

- Maximum Belt Speed 3.5m/s
- Temperature Rating -35°C to 82°C
- Minimum Pulley Diameter 250mm
- Blade Height 185mm
- Useable Blade Wear Length 100mm
- Blade Material Urethane (proprietary blend for abrasion resistance and long wear)
- Available for Belt Widths 650 to 2000mm
Other sizes available upon request.
- CEMA Cleaner Rating Class 3

U.S. Patent No. D482,508S

Section 8 - Specs and CAD Drawing (cont.)

8.2 CAD Drawing - MSP Precleaner minus 50mm and minus 200mm

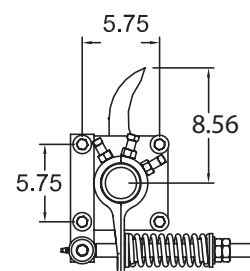
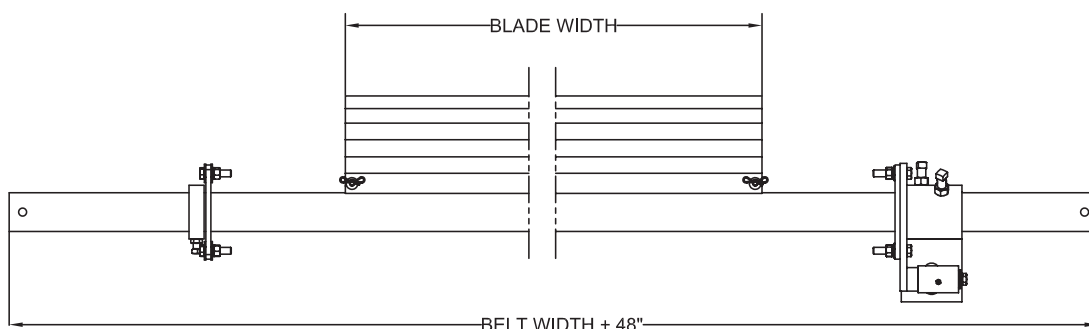
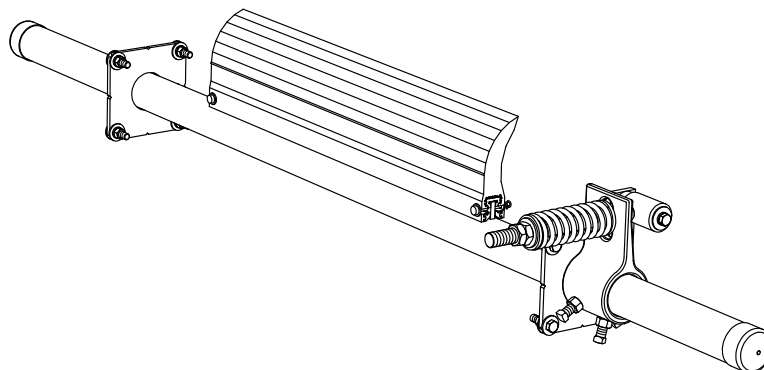

BLADE WIDTH MINUS 2"		
ASSY NUMBER	BELT WIDTH	BLADE WIDTH
75787	24" (600)	22" (550)
75788	30" (750)	28" (700)
75789	36" (900)	34" (850)
75790	42" (1050)	40" (1000)
75791	48" (1200)	46" (1150)
75792	54" (1350)	52" (1300)
75793	60" (1500)	58" (1450)
75794	72" (1800)	70" (1750)
76796	84" (2100)	82" (2050)

BLADE WIDTH MINUS 8"		
ASSY NUMBER	BELT WIDTH	BLADE WIDTH
75795	24" (600)	16" (400)
75796	30" (750)	22" (550)
75797	36" (900)	28" (700)
75798	42" (1050)	34" (850)
75799	48" (1200)	40" (1000)
75800	54" (1350)	46" (1150)
75801	60" (1500)	52" (1300)
76693	66" (1650)	58" (1450)
75802	72" (1800)	64" (1600)
76797	84" (2100)	76" (1900)

Section 9 - Replacement Parts

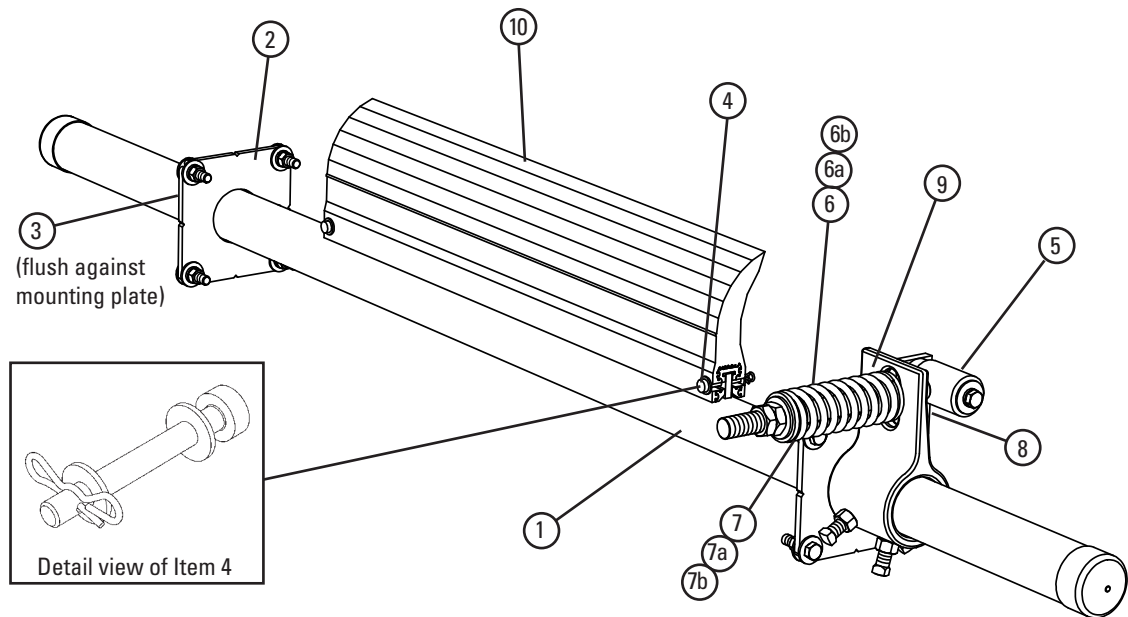

Replacement Parts

Ref	Description	Ordering Number	Item Code	Wt. Kg
1	650mm Pole	MSPP650	78301	21.0
	800mm Pole	MSPP800	78302	23.0
	1000mm Pole	MSPP1000	78303	25.5
	1200mm Pole	MSPP1200	78304	27.5
	1400mm Pole	MSPP1400	78305	30.5
	1600mm Pole	MSPP1600	78306	32.5
	1800mm Pole	MSPP1800	78307	34.5
	2000mm Pole	MSPP2000	78308	40.5
2	Mounting Plate Kit* (2 ea.)	MSPMPKM	78699	3.8
3	Pole Lock* (1 ea.)	MSPPL	75816	0.9
4	Blade Pin Kit* (1 ea.)	MSPBPK	75831	0.05
5	Pivot Arm Kit* (1 ea.)	QMTPAK	76096	2.0
6	Tension Spring - Purple (1 ea.) for blades 400 - 700mm	QMTS-P	75845	0.3
6a	Tension Spring - White (1 ea.) for blades 850 - 1750mm	PSTS-W	75898	0.5
6b	Tension Spring - Gold (1 ea.) for blades 1900 - 2050mm	QMTS-G	76484	1.2
7	Bushing Kit - Purple (2 ea.)	QMTBK-P	76097	0.1
7a	Bushing Kit - White (2 ea.)	QMTBK-W	76098	0.1
7b	Bushing Kit - Gold (2 ea.)	QMTBK-G	76540	0.1
8	Pivot Shaft Bracket Kit* (1 ea.)	QMTPSBK	76099	2.0
9	Torsion Arm Kit* (1 ea.)	PSTA	75896	4.5
-	QMT Spring Tensioner* - Purple (incl. 1 ea. Items 5, 6a, 7a, 8, & 9) for blades 400 - 700mm	QMTM-P	78695	9.3
-	QMT Spring Tensioner* - White (incl. 1 ea. Items 5, 6a, 7a, 8, & 9) for blades 850 - 1750mm	QMTM-W	78696	9.9
-	QMT Spring Tensioner* - Gold (incl. 1 ea. Items 5, 6b, 7b, 8, & 9) for blades 1900 - 2050mm	QMTM-G	78697	10.5

*Hardware Included
Lead Time: 1 working day

Replacement ConShear™ Blades

Ref	Blade Width	Ordering Number	Item Code
	mm		
19	200	CRB-200	78239
	300	CRB-300	78240
	350	CRB-350	78241
	450	CRB-450	78242
	600	CRB-600	78243
	750	CRB-750	78244
	800	CRB-800	78245
	950	CRB-950	78246
	1000	CRB-1000	78247
	1150	CRB-1150	78248
	1200	CRB-1200	78249
	1350	CRB-1350	78250
	1400	CRB-1400	78251
	1550	CRB-1550	78252
	1600	CRB-1600	78253
	1750	CRB-1750	78254
	1800	CRB-1800	78255
	1950	CRB-1950	78256

Order blade width for your belt width's material path: Belt Width Minus 50mm, Belt Width Minus 200mm or Belt Width Minus 350mm.
Lead Time: 1 working day

Spring Tensioner Selection Chart

Cleaner Blade Width	76074 QMT-P	76075 QMT-W	76843 QMT-G
ConShear 400 - 700mm	X		
ConShear 850 - 1750mm		X	
ConShear 1900 - 2050mm			X

Section 10 - Other Flexco Conveyor Products

Flexco provides many conveyor products that help your conveyors to run more efficiently and safely. These components solve typical conveyor problems and improve productivity.

Here is a quick overview on just a few of them:

MHS Secondary Cleaner with Service Advantage Cartridge

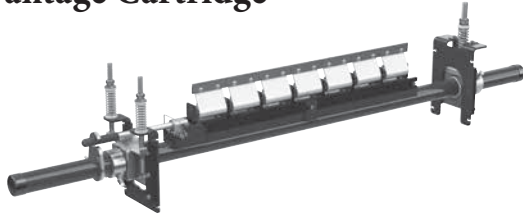

- An easy slide-out cartridge for service
- Cartridge design to speed up blade-change maintenance
- Patented PowerFlex™ Cushions for superior cleaning performance
- Compatible with Flexco mechanical splices

U-Type® Secondary Belt Cleaner

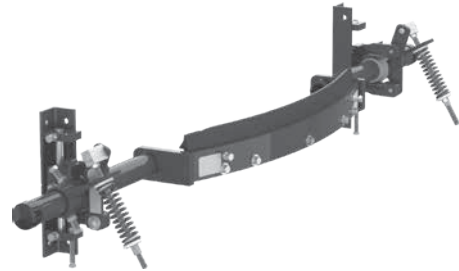

- Wipes the belt dry as final cleaner in system
- Automatic blade tensioning to the belt
- Easy, visual blade tension check
- Simple, one-pin blade replacement

Flexco Secondary Belt Cleaners



- “Limited space” cleaners for tight conveyor applications
- High Temp cleaners for severe, high heat applications
- A rubber-fingered cleaner for chevron and raised rib belts
- Multiple cleaner styles in stainless steel for corrosive applications

PT Max™ Belt Trainer



- Patented “pivot & tilt” design for superior training action
- Dual sensor rollers on each side to minimize belt damage
- Pivot point guaranteed not to freeze or seize up
- Available for topside and return side belts

DRX Impact Beds



- Exclusive Velocity Reduction Technology™ to better protect the belt
- Slide-Out Service™ gives direct access to all impact bars for change-out
- Impact bar supports for longer bar life
- 4 models to custom fit to the application

Belt Plows



- A belt cleaner for the tail pulley
- Exclusive blade design quickly spirals debris off the belt
- Economical and easy to service
- Available in vee or diagonal models

Flexco Europe GmbH • Maybachstrasse 9 • 72348 Rosenfeld • Germany
Tel: +49-7428-9406-0 • Fax: +49-7428-9406-260 • E-mail: europa@flexco.com

Visit www.flexco.com for other Flexco locations and products.

©2020 Flexible Steel Lacing Company. 09/09/20. For reorder: X2440

