

# MSP Precleaner

---

## Installation, Operation and Maintenance Manual

---

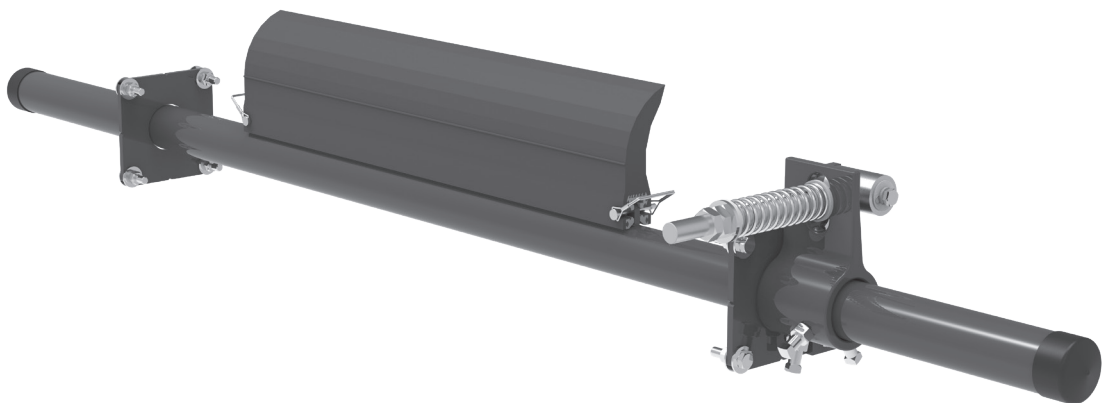

# MSP Precleaner

---

Serial Number: _____
Purchase Date: _____
Purchased From: _____
Installation Date: _____

Serial number information can be found on the Serial Number Label included in the Information Packet found in the cleaner carton.

This information will be helpful for any future inquiries or questions about belt cleaner replacement parts, specifications or troubleshooting.

# Table of Contents

---

<b>Section 1 - Important Information .....</b>	<b>4</b>
1.1 General Introduction.....	4
1.2 User Benefits .....	4
1.3 Service Option.....	4
<b>Section 2 - Safety Considerations and Precautions .....</b>	<b>5</b>
2.1 Stationary Conveyors.....	5
2.2 Operating Conveyors.....	5
<b>Section 3 - Pre-Installation Checks and Options .....</b>	<b>6</b>
3.1 Checklist.....	6
3.2 Cleaner Location Adjustments.....	7
3.3 Optional Installation Accessories.....	8
3.4 Correct Blade Installation and Tensioning .....	9
<b>Section 4 - Installation Instructions .....</b>	<b>10</b>
4.1 MSP Precleaner.....	10
<b>Section 5 - Pre-Operation Checklist and Testing .....</b>	<b>13</b>
5.1 Pre-Op Checklist.....	13
5.2 Test Run the Conveyor .....	13
<b>Section 6 - Maintenance .....</b>	<b>14</b>
6.1 New Installation Inspection.....	14
6.2 Routine Visual Inspection.....	14
6.3 Routine Physical Inspection .....	14
6.4 Blade Replacement Instructions.....	15
6.5 Maintenance Log.....	16
6.6 Cleaner Maintenance Checklist.....	17
<b>Section 7 - Troubleshooting .....</b>	<b>18</b>
<b>Section 8 - Specs and CAD Drawing.....</b>	<b>19</b>
8.1 Specs and Guidelines .....	19
8.2 CAD Drawing.....	20
<b>Section 9 - Replacement Parts.....</b>	<b>21</b>
9.1 Replacement Parts List .....	21
<b>Section 10 - Other Flexco Conveyor Products.....</b>	<b>22</b>

# Section 1 - Important Information

---

## 1.1 General Introduction

We at Flexco are very pleased that you have selected a Flexco MSP Precleaner for your conveyor system.

This manual will help you to understand the operation of this product and assist you in making it work up to its maximum efficiency over its lifetime of service.

It is essential for safe and efficient operation that the information and guidelines presented be properly understood and implemented. This manual will provide safety precautions, installation instructions, maintenance procedures and troubleshooting tips.

If, however, you have any questions or problems that are not covered, please visit our web site or contact our Customer Service Department.

**Visit [www.flexco.com](http://www.flexco.com) for other Flexco locations and products.**

Please read this manual thoroughly and pass it on to any others who will be directly responsible for installation, operation and maintenance of this cleaner. While we have tried to make the installation and service tasks as easy and simple as possible, it does however require correct installation and regular inspections and adjustments to maintain top working condition.

## 1.2 User Benefits

Correct installation and regular maintenance will provide the following benefits for your operation:

- Reduced conveyor downtime
- Reduced man-hour labor
- Lower maintenance budget costs
- Increased service life for the belt cleaner and other conveyor components

## 1.3 Service Option

The MSP Precleaner is designed to be easily installed and serviced by your on-site personnel. However, if you would prefer complete turn-key factory service, please contact your local Flexco Field Engineer or your Flexco Distributor.

## Section 2 - Safety Considerations and Precautions

---

Before installing and operating the MSP Precleaner, it is important to review and understand the following safety information.

There are set-up, maintenance and operational activities involving both stationary and operating conveyors. Each case has a safety protocol.

---

### 2.1 Stationary Conveyors

The following activities are performed on stationary conveyors:

- Installation
- Blade replacement
- Repairs
- Tension adjustments
- Cleaning

#### **DANGER**

It is imperative that OSHA/MSHA Lockout/Tagout (LOTO) regulations, 29 CFR 1910.147, be followed before undertaking the preceding activities. Failure to use LOTO exposes workers to uncontrolled behavior of the belt cleaner caused by movement of the conveyor belt. Severe injury or death can result.

#### **Before working:**

- Lockout/Tagout the conveyor power source
- Disengage any takeups
- Clear the conveyor belt or clamp securely in place

#### **WARNING**

#### **Use Personal Protective Equipment (PPE):**

- Safety eyewear
- Hardhats
- Safety footwear

Close quarters, springs and heavy components create a worksite that compromises a worker's eyes, feet and skull. PPE must be worn to control the foreseeable hazards associated with conveyor belt cleaners. Serious injuries can be avoided.

### 2.2 Operating Conveyors

There are two routine tasks that must be performed while the conveyor is running:

- Inspection of the cleaning performance
- Dynamic troubleshooting

#### **DANGER**

Every belt cleaner is an in-running nip hazard. Never touch or prod an operating cleaner. Cleaner hazards cause instantaneous amputation and entrapment.

#### **WARNING**

Conveyor chutes contain projectile hazards. Stay as far from the cleaner as practical and use safety eyewear and headgear. Missiles can inflict serious injury.

#### **WARNING**

Never adjust anything on an operating cleaner. Unforseeable belt projections and tears can catch on cleaners and cause violent movements of the cleaner structure. Flailing hardware can cause serious injury or death.

## Section 3 - Pre-installation Checks and Options

---

### 3.1 Checklist

- Check that the cleaner size is correct for the beltline width.
- Check the belt cleaner carton and make sure all the parts are included.
- Review the “Tools Needed” list on the top of the installation instructions.
- Check the conveyor site:
  - Will the cleaner be installed on a chute?
  - Are there obstructions that may require cleaner location adjustments?  
(see 3.2 - Cleaner Location Adjustments)
  - Is the install on an open head pulley requiring mounting structure?  
(see 3.3 - Optional Installation Accessories)

# Section 3 - Pre-installation Checks and Options

## 3.2 Cleaner Location Adjustments

In certain applications it is necessary to modify the location of the pre-cleaner pole due to permanent obstacles that obstruct the desired location. Relocating the pole location can be done easily and does not hinder the performance of the cleaner as long as the “C” dimension is maintained.

**NOTE:** In the following example we will be lowering the pole location in the “Y” direction, but the same method could also be applied in the “X” direction.

Conveyor situation:

Pulley Diameter: 300mm (12")

X = 155mm (6 1/8")

Y = 140mm (5 1/2")

C = 210mm (8 1/4")

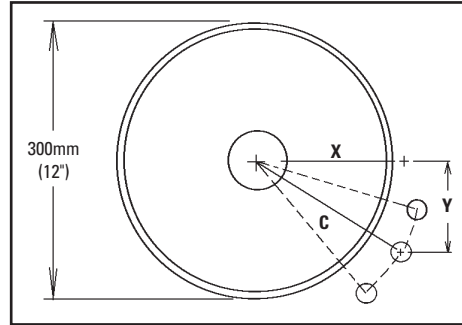

- Determine the given location dimensions and define the change needed.** After laying out the given X & Y dimensions, determine the distance of the modification required for adequate clearance of the pole and tensioning system. (In the example we decide to lower the pole 50mm (2") to clear the support structure).
- Write down known dimensions.** We can now determine two of the three required dimensions which will allow us to find the third. We know we cannot alter the “C” dimension, so this will remain the same. Also we are required to lower the unit in the “Y” dimension 50mm (2"), so we add 50mm (2") to the given “Y” dimension.

X = ?

Y = 140 + 50 = 190mm (5 1/2 + 2 = 7 1/2")

C = 210mm (8 1/4")

- Determine final dimension.** On a flat vertical surface, using a level, draw one horizontal line and one vertical line, creating a right triangle (Fig 3a). Measure down from the intersection the determined “Y” dimension and mark (Fig 3b). With the tape measure starting at the modified “Y” mark, swing the tape across the “X” line and mark at the “C” dimension where it crosses the “X” line (Fig 3c). Measure from the intersection to the “C” intersection and this will be your new “X” dimension (Fig. 3d).

X = 89mm (3 1/2")

Y = 190mm (7 1/2")

C = 210mm (8 1/4")

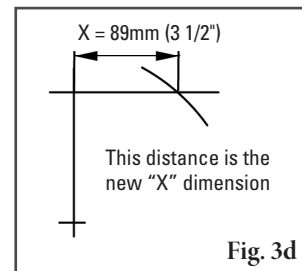
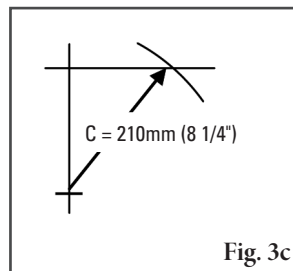
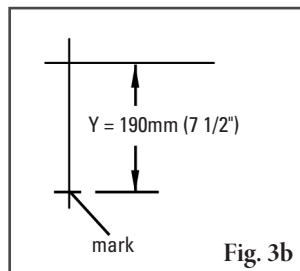
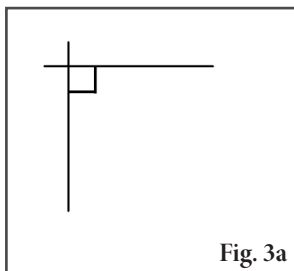

# Section 3 - Pre-Installation Checks and Options

## 3.3 Optional Installation Accessories

Versatile, adjustable brackets and plates that can be mounted on the conveyor structure so precleaners and secondary cleaners can be easily and quickly bolted into place. Pole extenders are also available for wide, non-standard conveyor structures.

- 
- Optional Mounting Bar Kit (incl. bolts, nuts and washers) (Item Code: 75830)**
  - For mounting precleaners on open head pulleys.
  - Weld on both sides of pulley and bolt on steel plates.
  - 38 x 405mm (1 1/2 x 16") with (4) 16mm (5/8") tapped holes



- Mounting Plate Kit (incl. 2 plates) (Item Code: 76537)**
- For use with Mounting Bars to mount cleaners on open head pulleys.
- 400 x 800mm (16 x 32") with (4) 16mm (5/8") holes

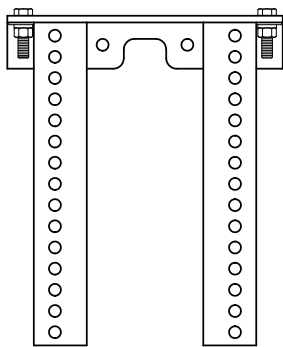

- SST Standard Mounting Bracket Kit (for SST XD Tensioner) (Item Code: 76071)**
- For most secondary cleaner installs.
- 325 x 388mm (13 x 15 1/2")

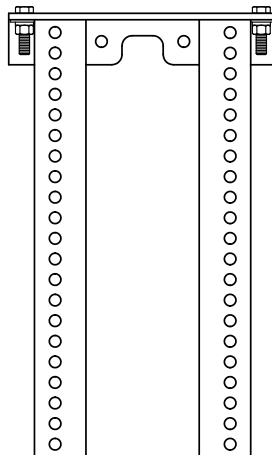

- SST Long Mounting Bracket Kit (for SST XD Tensioner) (Item Code: 76072)**
- For installations that require extra length legs.
- 325 x 538mm (13 x 21 1/2")

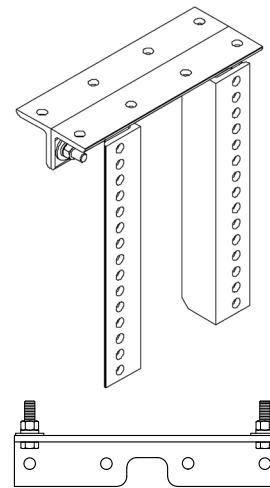

- SST Optional Top Angle Kit (for SST XD Tensioner) (Item Code: 76073)**
- Used with both standard and long mounting bracket kits for additional mounting options.
- 325mm (13") Length

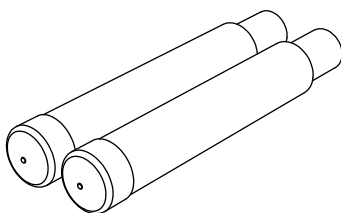

- Pole Extender Kit (incl. 2 pole extenders) (Item Code: 76024)**
- For cleaner sizes 1800mm (72") and larger
- Provides 750mm (30") of extended pole length

### Optional Mounting Kits (includes 2 brackets/bars)

DESCRIPTION	ORDERING NUMBER	ITEM CODE	WT. KG
Optional Mounting Bar Kit *	MMBK	75830	8.4
Mounting Plate Kit (incl. 2 plates)	MMPK	76537	63.5
Standard Mounting Bracket Kit *	SSTSMB	76071	15.6
Long Mounting Bracket Kit *	SSTLMB	76072	19.7
Optional Top Angle Kit *	SSTOTA	76073	4.8
Pole Extender Kit	MAPEK	76024	9.9

\*Hardware Included  
Lead time: 1 working day



# Section 3 - Pre-Installation Checks and Options

## 3.4 Correct Blade Installation and Tensioning

For optimal cleaning efficiency and long wear life, the ConShear™ blade must be located and tensioned correctly on the belt head pulley. If the cleaner pole is in the wrong location the performance of the new blade may be adversely affected. See “Possible Problems” below. For tensioning, please follow these instructions.

### Correct Location:

When blade contact is made against the head pulley (prior to tensioning), there should be a 2–3mm (1/16–1/8”) gap at the bottom of the blade face (Fig. 1).

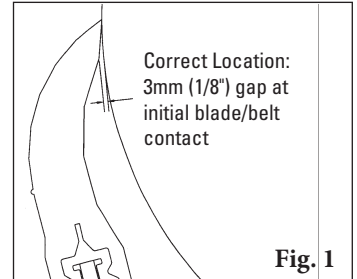

### Possible Problems:

- Pole location too far out - The initial blade/belt contact gap will be larger than 3mm (1/8”) (Fig. 2). If the blade is correctly tensioned it may flip through before it is fully worn. If tensioned too lightly, it will develop the “smile effect” quickly and not clean properly.
- Pole location too far in - If there is no gap at the initial blade/belt contact (Fig. 3), the tip of the blade may not be touching the belt. In this case, the blade will push away and lose its shearing (cleaning) effect. The blade may also develop a flap at the tip which may trap material.

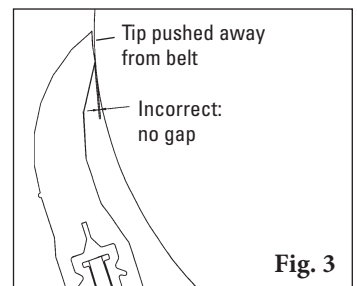
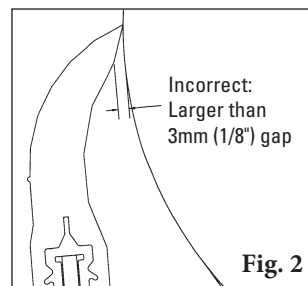

### Correct Tensioning:

The blade should be tensioned until the gap is gone (Fig. 4).

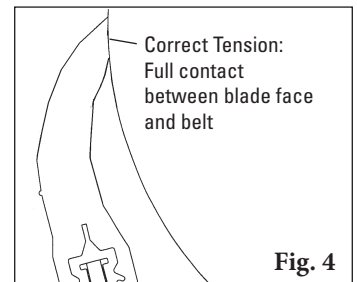

### The “Material Path” Option

For optimal cleaning and reduced blade retensioning, the cleaner blade width should be sized to fit the material path of the belt. The material path is typically the center 2/3 of the belt width. Choosing a blade only slightly wider than the material path can decrease differential blade wear which reduces blade retensioning maintenance, as well as reducing the frequency of blade replacement.

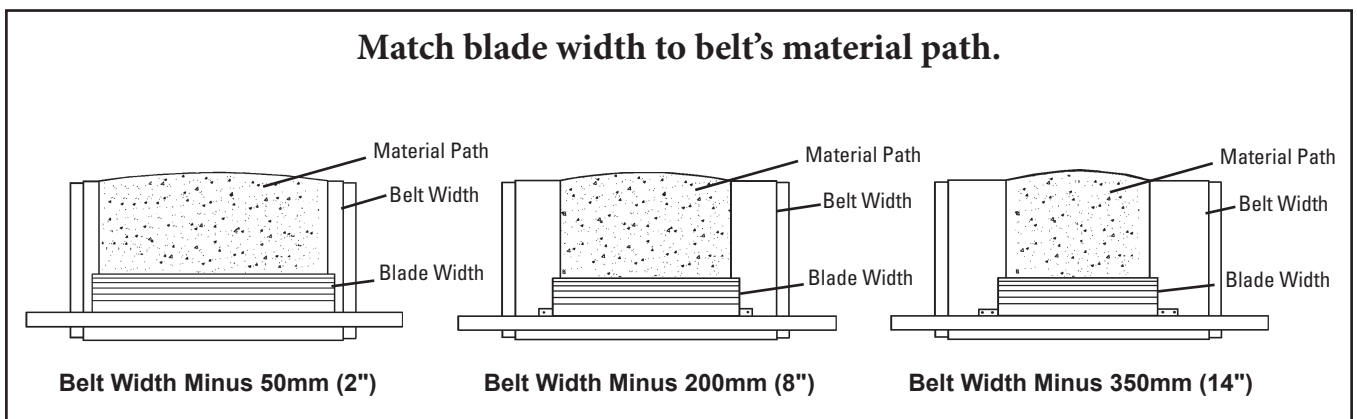

# Section 4 - Installation Instructions

## 4.1 MSP Precleaner

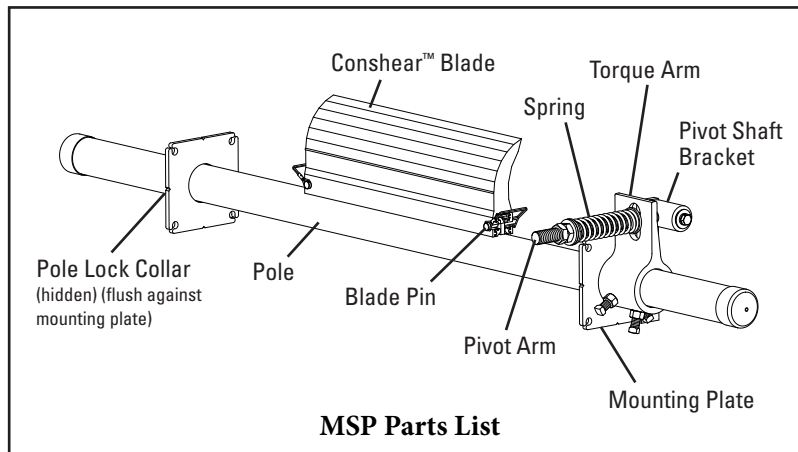

**PHYSICALLY LOCK OUT AND TAG THE CONVEYOR AT THE POWER SOURCE BEFORE YOU BEGIN CLEANER INSTALLATION.**

### Tools Needed:

- 14mm (9/16") Wrench
- 16mm (5/8") Wrench
- 19 mm (3/4") Wrench
- 24mm (15/16") Wrench
- 35mm (1-3/8") Wrench
- **OR** Large Adjustable/Crescent Wrench
- Torch or welder (as needed)
- Tape Measure
- Level
- Marking pen or soapstone

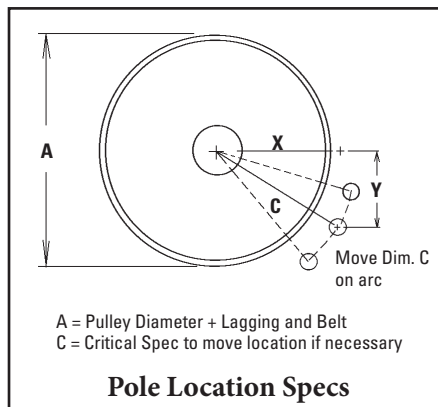

### Pole Location Chart

A		X		Y		C	
mm	in.	mm	in.	mm	in.	mm	in.
250	10	68	2 5/8	230	9	240	9 4/8
275	11	88	3 4/8	230	9	246	9 6/8
300	12	102	4	230	9	252	9 7/8
325	13	130	5 1/8	230	9	264	10 3/8
350	14	142	5 5/8	230	9	270	10 5/8
375	15	164	6 4/8	230	9	282	11 1/8
400	16	176	7 1/8	230	9	290	11 1/2
425	17	196	7 7/8	230	9	302	12
450	18	204	8 1/4	230	9	308	12 1/4
475	19	222	9	230	9	320	12 3/4
500	20	232	9 3/8	230	9	326	13
525	21	248	10	230	9	338	13 1/2
550	22	266	10 3/4	230	9	352	14
575	23	282	11 3/8	230	9	364	14 1/2
600	24	298	12	230	9	376	15
625	25	312	12 5/8	230	9	388	15 1/2
650	26	330	13 1/4	230	9	402	16
675	27	344	13 7/8	230	9	414	16 1/2
700	28	358	14 3/8	230	9	426	17
725	29	372	15	230	9	438	17 1/2
750	30	390	15 5/8	230	9	452	18
775	31	402	16 1/8	230	9	464	18 1/2
800	32	416	16 3/4	230	9	476	19
825	33	430	17 1/4	230	9	488	19 1/2
850	34	446	17 7/8	230	9	502	20
875	35	460	18 3/8	230	9	514	20 1/2
900	36	474	19	230	9	526	21
925	37	486	19 1/2	230	9	538	21 1/2
950	38	502	20	230	9	552	22
975	39	514	20 5/8	230	9	564	22 1/2
1000	40	528	21 1/8	230	9	576	23
1025	41	542	21 3/4	230	9	588	23 1/2
1050	42	556	22 1/4	230	9	602	24

1. **Locate the correct pole position.** Measure and determine Dimension A (see instructions above). Find Dimension A on the Pole Location Chart at right and determine Dimensions X, Y and C. Measure out horizontally from the center of the pulley shaft Dim X and mark. From that mark, draw a long vertical line down, then measure and mark Dim Y. This indicates the location of the center of the cleaner pole. Measure and mark both sides.

**NOTE:** If the location is obstructed, use Dim. C and move on an arc from the center of the pulley shaft to find an open position. Dim. C must remain constant to correctly locate the pole (see drawing above).

**NOTE:** For open head installs, first add mounting support materials to the structure.

## Section 4 - Installation Instructions

### 4.1 MSP Precleaner

2. **Mark and cut the mounting plate holes.** Using the mounting plate template provided in the instruction packet, position the large pole access hole on the chute, aligning the hole notches with the layout lines. Position the keyway toward the pulley. Trace the pole cutout and mounting holes (Fig. 2). Cut the holes on both sides of the chute.

**NOTE:** Hole cutouts are slotted for later adjustment if needed.

3. **Install the mounting plates.** Bolt the mounting plates to the chute with bolts provided. Center plates on the slotted holes and tighten bolts (Fig. 3).
4. **Install the pole.** Remove both blade pins and blade from the pole and insert the pole in through the mounting plates (Fig. 4).
5. **Center the cleaner on the belt and lock in place.** Reinstall the blade with both blade pins. Center the blade on the belt and install the pole lock collar onto the pole (on the end opposite the end to be used for the tensioner), snugly up to the mounting plate. Rotate the blade up to the belt and check to insure that the blade is square to the pulley face (Fig. 5). If not, loosen a mounting plate on one side and adjust the plate forward or backward to square the blade to the pulley, and retighten the bolts.
6. **Install the QMT spring tensioner.** Remove the adjusting nuts and springs from the pivot rod. Insert the pivot arm through the slot in the torque arm. Slide the torque arm onto the pole end (be sure the rotation of the arm is correct to tension the blade) and rotate it until the pivot shaft bracket lines up with the desired bolt holes (Fig. 6). Remove half of the bolts, nuts, and washers from the mounting plate and reinstall them through the pivot shaft bracket and mounting plate.
7. **Reassemble the spring assembly.** Slide the spring, washer and bushings onto the pivot arm and turn the two adjusting nuts so about 1/4" (6mm) of the pivot arm is exposed above the nuts (Fig. 7).

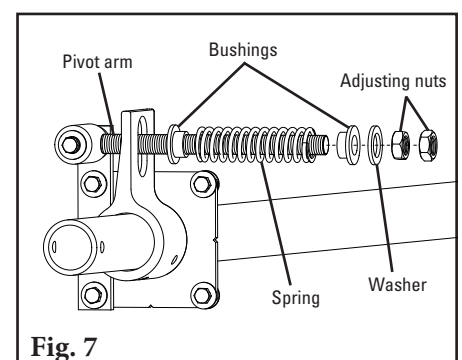
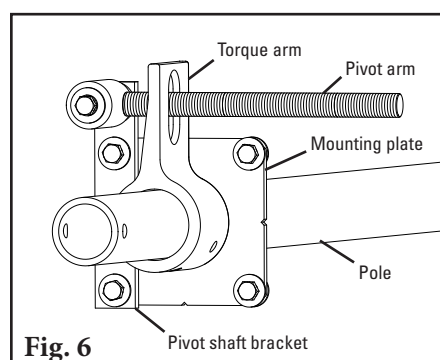
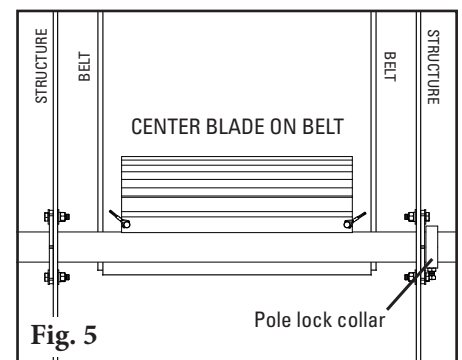
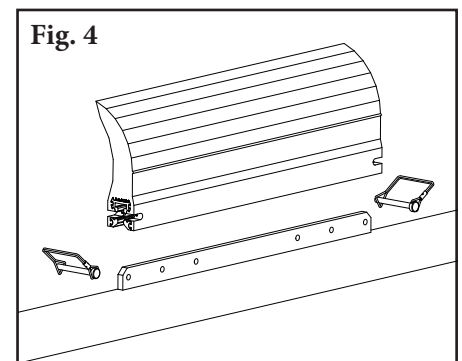
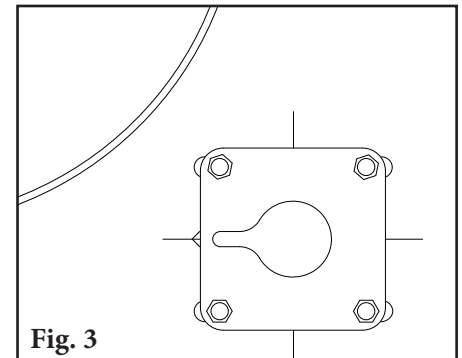
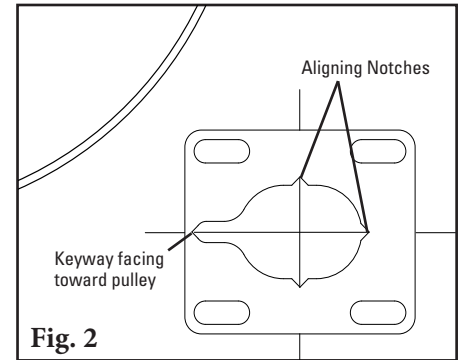

# Section 4 - Installation Instructions

## 4.1 MSP Precleaner

8. **Tension the blade to the belt.** Rotate the blade until it makes contact with the belt. While holding the spring bushing flat on the torque arm, rotate the torque arm until the pivot arm is against the end of the slot nearest the pole. Tighten the locking bolts and jam nuts on the torque arm (Fig. 8).

**NOTE:** The torque arm should be up against the mounting plate.

9. **Set the correct blade tension.** Refer to the chart on the pivot shaft bracket for the spring length required for the blade width. Lightly pull the pivot arm toward the end of the torque arm slot nearest the pole and turn the adjusting nuts until the required spring length is achieved. Tighten the jam nut.

10. **Confirm the correct pole location.**

After the cleaner is installed, slide the Pole Location Gauge (provided in the instruction packet) between the cleaner pole and the pulley, until it stops at a step (Fig. 9). Read the flat area where the pole is resting (Fig. 9a). This diameter should be equal to Dim A used in Step 1.

**NOTE:** If the diameter reading on the Pole Location Gauge does not read the same as in Step 1, check the “C” dimension and correct accordingly.

**Test run the cleaner.** Run the conveyor for at least 15 minutes and inspect the cleaning performance. Check the spring length for proper tensioning. Make adjustments as necessary.

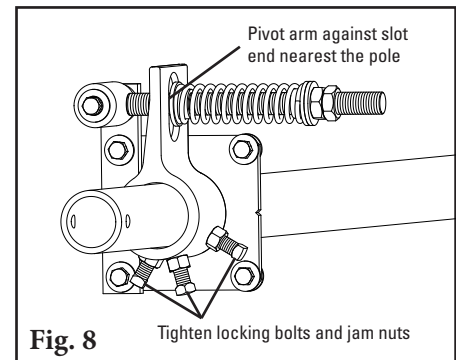

Fig. 8

### QMT Spring Length Chart

Blade Width	Purple Springs	White Springs	Gold Springs
mm	mm	mm	mm
450	131	159	N/A
600	121	156	N/A
750	105	149	N/A
800	N/A	146	156
950	N/A	143	156
1000	N/A	140	152
1150	N/A	137	149
1200	N/A	130	149
1350	N/A	127	146
1400	N/A	124	143
1550	N/A	N/A	143
1600	N/A	N/A	140
1750	N/A	N/A	131
1800	N/A	N/A	130
1950	N/A	N/A	130
2100	N/A	N/A	127

Shading indicates preferred spring option.

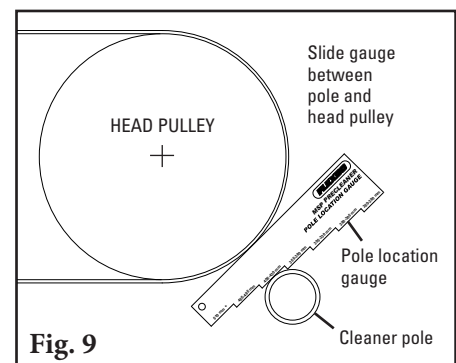
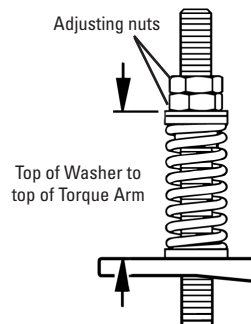

Fig. 9

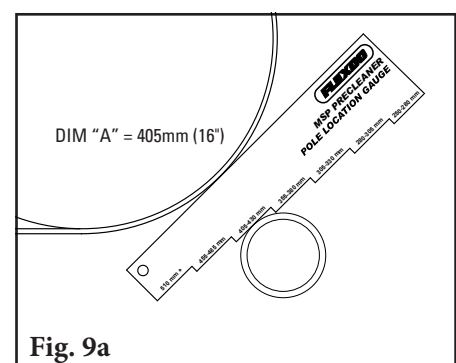

Fig. 9a

## Section 5 - Pre-Operation Checklist and Testing

---

### 5.1 Pre-Op Checklist

- Recheck that all fasteners are tightened properly.
- Add pole caps.
- Apply all supplied labels to the cleaner.
- Check the blade location on the belt.
- Be sure that all installation materials and tools have been removed from the belt and the conveyor area.

### 5.2 Test Run the Conveyor

- Run the conveyor for at least 15 minutes and inspect the cleaning performance.
- Check the tensioner spring for recommended length (proper tensioning).
- Make adjustments as necessary.

**NOTE:** Observing the cleaner when it is running and performing properly will help to detect problems or when adjustments are needed later.

## Section 6 - Maintenance

---

Flexco belt cleaners are designed to operate with minimum maintenance. However, to maintain superior performance some service is required. When the cleaner is installed a regular maintenance program should be set up. This program will ensure that the cleaner operates at optimal efficiency and problems can be identified and fixed before the cleaner stops working.

All safety procedures for inspection of equipment (stationary or operating) must be observed. The MSP Precleaner operates at the discharge end of the conveyor and is in direct contact with the moving belt. Only visual observations can be made while the belt is running. Service tasks can be done only with the conveyor stopped and by observing the correct lockout/tagout procedures.

### 6.1 New Installation Inspection

After the new cleaner has run for a few days a visual inspection should be made to ensure the cleaner is performing properly. Make adjustments as needed.

### 6.2 Routine Visual Inspection (every 2-4 weeks)

A visual inspection of the cleaner and belt can determine:

- If the spring length is the correct length for optimal tensioning.
- If the belt looks clean or if there are areas that are dirty.
- If the blade is worn out and needs to be replaced.
- If there is damage to the blade or other cleaner components.
- If fugitive material is built up on the cleaner or in the transfer area.
- If there is cover damage to the belt.
- If there is vibration or bouncing of the cleaner on the belt.
- If a snub pulley is used, a check should be made for material buildup on the pulley.

If any of the above conditions exist, a determination should be made on when the conveyor can be stopped for cleaner maintenance.

### 6.3 Routine Physical Inspection (every 6-8 weeks)

When the conveyor is not in operation and properly locked and tagged out a physical inspection of the cleaner to perform the following tasks:

- Clean material buildup off of the cleaner blade and pole.
- Closely inspect the blade for wear and any damage. Replace if needed.
- Check both blade pins and retaining clips for proper installation and condition. Replace if needed.
- Ensure full blade to belt contact.
- Inspect the cleaner pole for damage.
- Inspect all fasteners for tightness and wear. Tighten or replace as needed.
- Replace any worn or damaged components.
- Check the tension of the cleaner blade to the belt. Adjust the tension if necessary using the chart on the cleaner or the one on Page 12.
- When maintenance tasks are completed, test run the conveyor to ensure the cleaner is performing properly.

# Section 6 - Maintenance

## 6.4 Blade Replacement Instructions

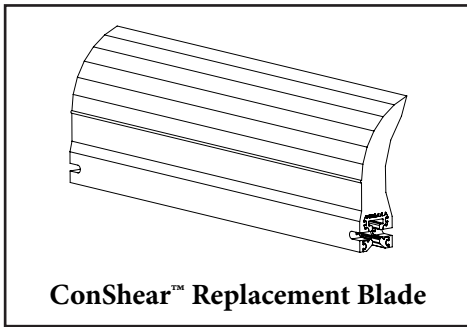

### Tools Needed:

- (2) 38mm (1-1/2") Wrench  
OR (2) Large Adjustable/Crescent Wrench
- Tape Measure
- Wire Brush (for cleaning pole)
- Small Putty Knife (for cleaning pole)

**PHYSICALLY LOCK OUT AND TAG THE CONVEYOR AT THE POWER SOURCE BEFORE YOU BEGIN CLEANER INSTALLATION.**

**1. Remove the tension.**  
Loosen the adjusting nuts until flush with the pivot arm (Fig. 1).

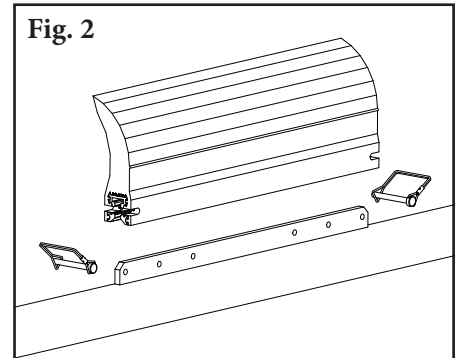
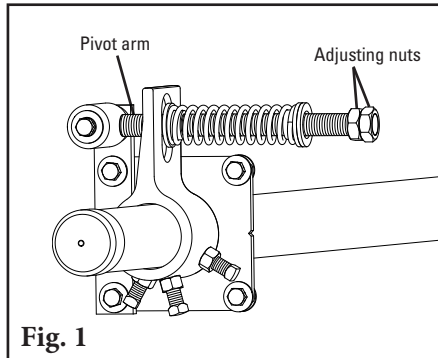

**2. Remove the worn blade.**  
Remove the blade pins to remove the blade from the pole (Fig. 2). Clean all fugitive material from the pole.

**NOTE:** If blade is hard to remove use a screwdriver or hammer to loosen.

- 3. Install the new blade.** First, slide the new blade onto the pole, and lock it into place with the far blade pin. Then, reinstall the remaining blade pin.
- 4. Reset the correct blade tension.** Refer to the chart for the spring length required for the blade width. Lightly pull the pivot arm toward the end of the torque arm slot nearest the pole and turn the adjusting nut until the required spring length is achieved. Tighten the jam nut.

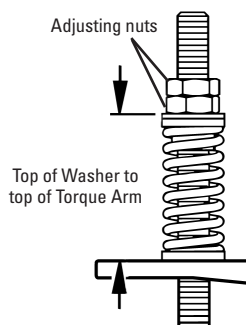

### OMT Spring Length Chart

Blade Width	Purple Springs	White Springs	Gold Springs
mm	mm	mm	mm
450	131	159	N/A
600	121	156	N/A
750	105	149	N/A
800	N/A	146	156
950	N/A	143	156
1000	N/A	140	152
1150	N/A	137	149
1200	N/A	130	149
1350	N/A	127	146
1400	N/A	124	143
1550	N/A	N/A	143
1600	N/A	N/A	140
1750	N/A	N/A	131
1800	N/A	N/A	130
1950	N/A	N/A	130
2100	N/A	N/A	127

Shading indicates preferred spring option.

**NOTE:** The chart is also on the cleaner's pivot shaft bracket for future reference for retensioning maintenance.

**Test run the cleaner.** Run the conveyor for at least 15 minutes and inspect the cleaning performance. Check the spring length for proper tensioning. Make adjustments as necessary.

# Section 6 - Maintenance

---

## 6.5 Maintenance Log

Conveyor Name/No. \_\_\_\_\_

Date: \_\_\_\_\_ Work done by: \_\_\_\_\_ Service Quote #: \_\_\_\_\_

Activity: \_\_\_\_\_

---

Date: \_\_\_\_\_ Work done by: \_\_\_\_\_ Service Quote #: \_\_\_\_\_

Activity: \_\_\_\_\_

---

Date: \_\_\_\_\_ Work done by: \_\_\_\_\_ Service Quote #: \_\_\_\_\_

Activity: \_\_\_\_\_

---

Date: \_\_\_\_\_ Work done by: \_\_\_\_\_ Service Quote #: \_\_\_\_\_

Activity: \_\_\_\_\_

---

Date: \_\_\_\_\_ Work done by: \_\_\_\_\_ Service Quote #: \_\_\_\_\_

Activity: \_\_\_\_\_

---

Date: \_\_\_\_\_ Work done by: \_\_\_\_\_ Service Quote #: \_\_\_\_\_

Activity: \_\_\_\_\_

---

Date: \_\_\_\_\_ Work done by: \_\_\_\_\_ Service Quote #: \_\_\_\_\_

Activity: \_\_\_\_\_

---

Date: \_\_\_\_\_ Work done by: \_\_\_\_\_ Service Quote #: \_\_\_\_\_

Activity: \_\_\_\_\_

---

Date: \_\_\_\_\_ Work done by: \_\_\_\_\_ Service Quote #: \_\_\_\_\_

Activity: \_\_\_\_\_



# Section 6 - Maintenance

## 6.6 Cleaner Maintenance Checklist

Site: \_\_\_\_\_ Inspected by: \_\_\_\_\_ Date: \_\_\_\_\_

Belt Cleaner: \_\_\_\_\_ Serial Number: \_\_\_\_\_

Blade Width:  Belt minus 50mm (2")  Belt minus 200mm (8")  Belt minus 350mm (14")

**Beltline Information:**

Beltline Number: \_\_\_\_\_ Belt Condition: \_\_\_\_\_

Belt Width:  450mm (18")  600mm (24")  750mm (30")  900mm (36")  1050mm (42")  1200mm (48")  1350mm (54")  1500mm (60")  1800mm (72")  2100mm (84")  2400mm (96")

Head Pulley Diameter (Belt & Lagging): \_\_\_\_\_ Belt Speed: \_\_\_\_\_ m/s Belt Thickness: \_\_\_\_\_

Belt Splice: \_\_\_\_\_ Condition of Splice: \_\_\_\_\_ Number of Splices: \_\_\_\_\_  Skived  Unskived

Material conveyed: \_\_\_\_\_

Days per week run: \_\_\_\_\_ Hours per day run: \_\_\_\_\_

**Blade Life:**

Date blade installed: \_\_\_\_\_ Date blade inspected: \_\_\_\_\_ Estimated blade life: \_\_\_\_\_

Is blade making complete contact with belt?  Yes  No

Distance from wear line: Left \_\_\_\_\_ Middle \_\_\_\_\_ Right \_\_\_\_\_

Blade condition:  Good  Grooved  Smiled  Not contacting belt  Damaged

Measurement of spring: Required: \_\_\_\_\_ Currently: \_\_\_\_\_

Was Cleaner Adjusted:  Yes  No

Pole Condition:  Good  Bent  Worn

Lagging:  Side Lag  Ceramic  Rubber  Other  None

Condition of lagging:  Good  Bad  Other \_\_\_\_\_

**Cleaner's Overall Performance:** (Rate the following 1 - 5, 1= very poor - 5 = very good)

Appearance: \_\_\_\_\_ Comments: \_\_\_\_\_

Location: \_\_\_\_\_ Comments: \_\_\_\_\_

Maintenance: \_\_\_\_\_ Comments: \_\_\_\_\_

Performance: \_\_\_\_\_ Comments: \_\_\_\_\_

Other comments: \_\_\_\_\_

\_\_\_\_\_  
\_\_\_\_\_  
\_\_\_\_\_  
\_\_\_\_\_

## Section 7 - Troubleshooting

Problem	Possible Cause	Possible Solutions
Poor Cleaning Performance	Cleaner under-tensioned	Adjust to correct tension - see chart
	Cleaner over-tensioned	Adjust to correct tension - see chart
	Cleaner installed in wrong location	Verify "C" dimension, relocate to correct dimension
	Cleaner blade worn or damaged	Replace cleaner blade
Rapid Blade Wear	Tension on cleaner too high/low	Adjust to correct tension - see chart
	Cleaner not located correctly	Check cleaner location for correct dimensions
	Blade attack angle incorrect	Check cleaner location for correct dimensions
	Material too abrasive for blade	Option: if vulcanized belt, switch to alternate cleaner with metal blades
	Mechanical splice damaging blade	Repair, skive or replace splice
Center wear on blade (smile effect)	Blade wider than material path	Replace blade with width to match material path
	Tension on cleaner too high/low	Adjust to correct tension - see chart
Unusual wear or damage to blade	Mechanical splice damaging blade	Repair, skive or replace splice
	Belt damaged or ripped	Repair or replace belt
	Cleaner not correctly located	Verify "C" dimension, relocate to correct dimension
	Damage to pulley or pulley lagging	Repair or replace pulley
Vibration or noise	Cleaner not located correctly	Verify "C" dimension, relocate to correct dimension
	Blade attack angle incorrect	Verify "C" dimension, relocate to correct dimension
	Cleaner running on empty belt (dry)	Use a spray pole when the belt is empty
	Cleaner tension too high/low	Adjust to correct tension or slight adjust to diminish
	Cleaner locking bolts not secure	Check and tighten all bolts and nuts
	Cleaner not square to head pulley	Verify "C" dimension, relocate to correct dimension
	Material buildup in chute	Clean up build-up on cleaner and in chute
Cleaner being pushed away from pulley	Cleaner tension not set correctly	Ensure correct tension/increase tension slightly
	Sticky material is overburdening cleaner	Increase tension; replace with cleaner with metal tips; replace with larger size cleaner
	Cleaner not set up correctly	Confirm location dimensions are equal on both sides
	Pole too far out ("C" dimension too large)	Verify "C" dimension, relocate to correct dimension

# Section 8 - Specs and CAD Drawing

## 8.1 Specs and Guidelines

### Pole Length Specifications\*

CLEANER SIZE		POLE LENGTH		MAXIMUM CONVEYOR SPAN	
mm	in.	mm	in.	mm	in.
650	30	2133	84	1883	74
800	36	2286	90	2036	80
1000	42	2438	96	2188	86
1200	48	2590	102	2340	92
1400	54	2895	108	2645	98
1600	60	3054	114	2804	104
1800	72	3206	126	2956	116
2000	84	3511	138	3261	128

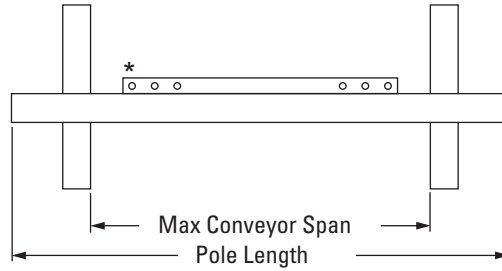

\*Each pole size can be used with a blade size either belt width minus 50mm (2"), belt width minus 200mm (8"), or belt width minus 350mm (14").

\*For special extra long pole length requirements a Pole Extender Kit (#76024) is available that provides 750mm (30") of extended pole length. Pole Diameter - 73mm (2-7/8")

### Clearance Guidelines for Installation

HORIZONTAL CLEARANCE REQUIRED		VERTICAL CLEARANCE REQUIRED	
mm	in.	mm	in.
100	4	250	10

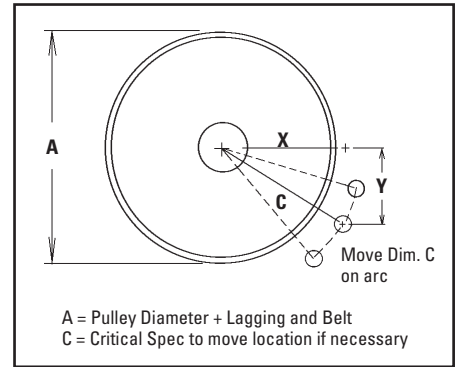
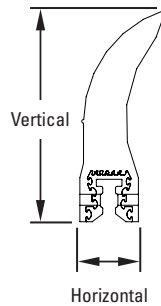

A = Pulley Diameter + Lagging and Belt  
C = Critical Spec to move location if necessary

### QMT Spring Length Chart

Blade Width	Purple Springs	White Springs	Gold Springs
mm	mm	mm	mm
450	131	159	N/A
600	121	156	N/A
750	105	149	N/A
800	N/A	146	156
950	N/A	143	156
1000	N/A	140	152
1150	N/A	137	149
1200	N/A	130	149
1350	N/A	127	146
1400	N/A	124	143
1550	N/A	N/A	143
1600	N/A	N/A	140
1750	N/A	N/A	131
1800	N/A	N/A	130
1950	N/A	N/A	130
2100	N/A	N/A	127

Shading indicates preferred spring option.

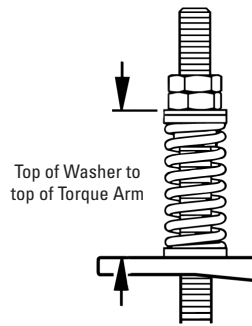

### Pole Location Chart

A		X		Y		C	
mm	in.	mm	in.	mm	in.	mm	in.
250	10	68	2 5/8	230	9	240	9 4/8
275	11	88	3 4/8	230	9	246	9 6/8
300	12	102	4	230	9	252	9 7/8
325	13	130	5 1/8	230	9	264	10 3/8
350	14	142	5 5/8	230	9	270	10 5/8
375	15	164	6 4/8	230	9	282	11 1/8
400	16	176	7 1/8	230	9	290	11 1/2
425	17	196	7 7/8	230	9	302	12
450	18	204	8 1/4	230	9	308	12 1/4
475	19	222	9	230	9	320	12 3/4
500	20	232	9 3/8	230	9	326	13
525	21	248	10	230	9	338	13 1/2
550	22	266	10 3/4	230	9	352	14
575	23	282	11 3/8	230	9	364	14 1/2
600	24	298	12	230	9	376	15
625	25	312	12 5/8	230	9	388	15 1/2
650	26	330	13 1/4	230	9	402	16
675	27	344	13 7/8	230	9	414	16 1/2
700	28	358	14 3/8	230	9	426	17
725	29	372	15	230	9	438	17 1/2
750	30	390	15 5/8	230	9	452	18
775	31	402	16 1/8	230	9	464	18 1/2
800	32	416	16 3/4	230	9	476	19
825	33	430	17 1/4	230	9	488	19 1/2
850	34	446	17 7/8	230	9	502	20
875	35	460	18 3/8	230	9	514	20 1/2
900	36	474	19	230	9	526	21
925	37	486	19 1/2	230	9	538	21 1/2
950	38	502	20	230	9	552	22
975	39	514	20 5/8	230	9	564	22 1/2
1000	40	528	21 1/8	230	9	576	23
1025	41	542	21 3/4	230	9	588	23 1/2
1050	42	556	22 1/4	230	9	602	24

### Specifications:

- Maximum Belt Speed .....3.5 m/s (700 FPM)
- Temperature Rating .....-35 to 82°C (-30 to 180°F)
- Minimum Pulley Diameter .....250mm (10")
- Blade Height .....185mm (7-1/4")
- Usable Blade Wear Length .....100mm (4")
- Blade Material.....Polyurethane (proprietary blend for abrasion resistance and long wear)
- Available for Belt Widths.....600 to 2100mm (24 to 84").  
Other sizes available upon request.
- CEMA Cleaner Rating.....Class 3

U.S. Patent No. D482,508S



# Section 8 - Specs and CAD Drawing

## 8.2 CAD Drawing - MSP Precleaner

BLADE WIDTH MINUS 14" (350MM)				
BELT WIDTH		BLADE WIDTH		ITEM CODE
IN	MM	IN	MM	
42	1050	28	700	77658
48	1200	34	850	77659
54	1350	40	1000	77660
60	1500	46	1150	77661
72	1800	58	1450	77662
84	2100	70	1750	77663

BLADE WIDTH MINUS 8" (200MM)				
BELT WIDTH		BLADE WIDTH		ITEM CODE
IN	MM	IN	MM	
24	600	16	400	75795
30	750	22	550	75796
36	900	28	700	75797
42	1050	34	850	75798
48	1200	40	1000	75799
54	1350	46	1150	75800
60	1500	52	1300	75801
66	1650	58	1450	76693
72	1800	64	1600	75802
84	2100	76	1900	76797
96	2400	88	2200	90145
108	2700	100	2500	90146

BLADE WIDTH MINUS 2" (50MM)				
BELT WIDTH		BLADE WIDTH		ITEM CODE
IN	MM	IN	MM	
24	600	22	550	75787
30	750	28	700	75788
36	900	34	850	75789
42	1050	40	1000	75790
48	1200	46	1150	75791
54	1350	52	1300	75792
60	1500	58	1450	75793
72	1800	70	1750	75794
84	2100	82	2050	76796
96	2400	94	2350	90143
108	2700	106	2650	90144

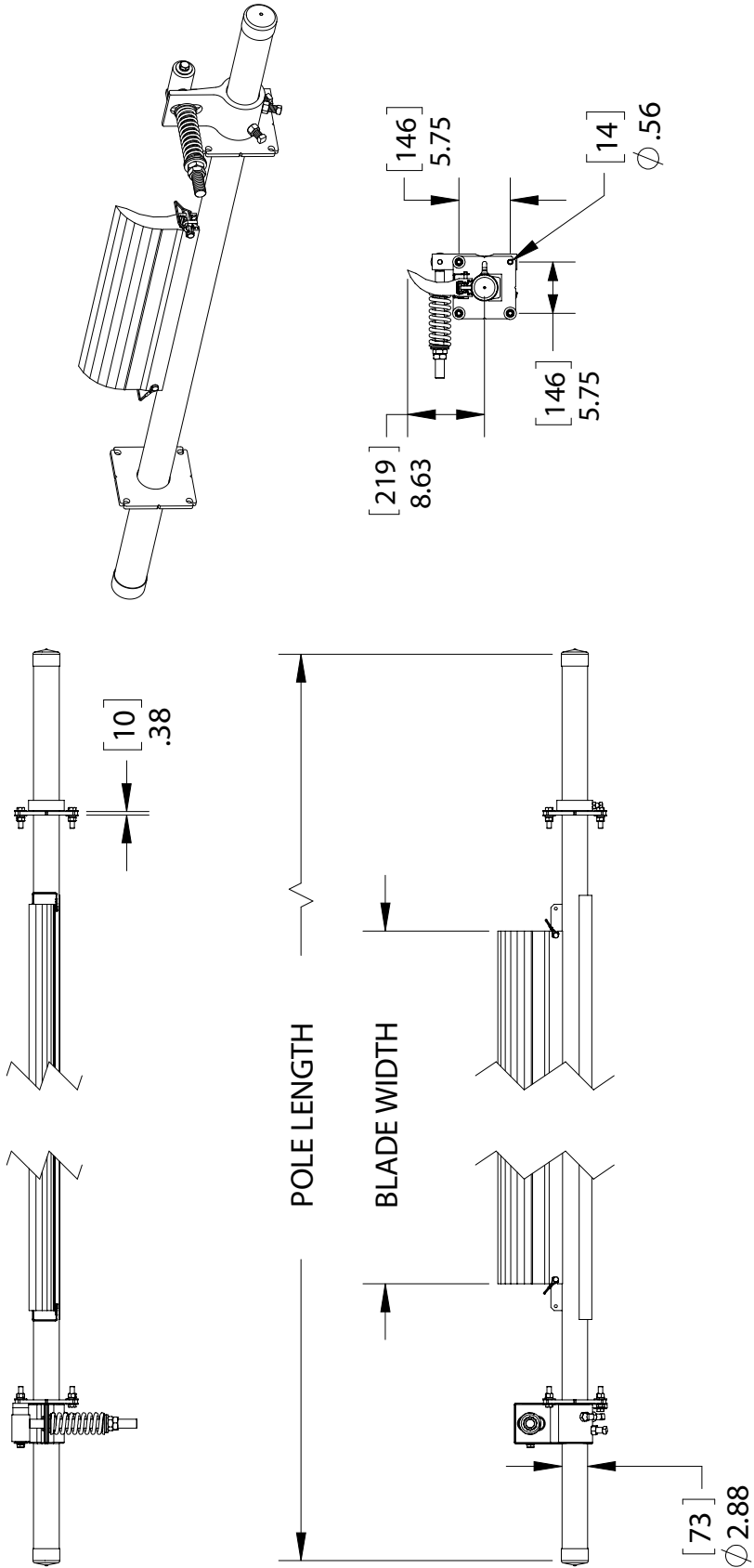

# Section 9 - Replacement Parts

## 9.1 Replacement Parts List

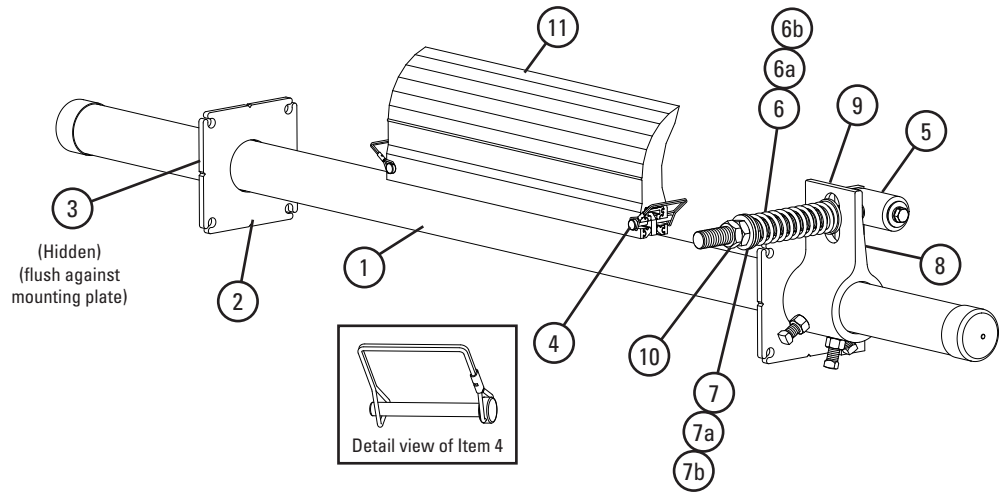

### Replacement Parts

REF	DESCRIPTION	ORDERING NUMBER	ITEM CODE	WT. KG
1	650mm (30") Pole	MSPP650	78301	20.9
	800mm (36") Pole	MSPP800	78302	22.9
	1000mm (42") Pole	MSPP1000	78303	25.2
	1200mm (48") Pole	MSPP1200	78304	27.2
	1400mm (54") Pole	MSPP1400	78305	29.0
	1600mm (60") Pole	MSPP1600	78306	30.4
	1800mm (72") Pole	MSPP1800	78307	34.5
	2000mm (84") Pole	MSPP2000	78308	40.5
2	Mounting Plate Kit* (2 ea.)	MSPMPK	75811	3.8
3	Pole Lock* (1 ea.)	MSPPL	75816	0.9
4	Blade Pin Kit* (1 ea.)	MSPBP	107852	0.05
5	Pivot Arm Kit* (1 ea.)	QMTPAK	76096	2.0
6	Tension Spring - Purple (1 ea.) for blades 200-700mm (8-28")	QMTS-P	75845	0.3
6a	Tension Spring - White (1 ea.) for blades 850-1750mm (34-70")	PSTS-W	75898	0.8
6b	Tension Spring - Gold (1 ea.) for blades 1900-2050mm (76-82")	QMTS-G	76484	1.1
7	Bushing Kit - Purple (2 ea.)	QMTBK-P	76097	0.05
7a	Bushing Kit - White (2 ea.)	QMTBK-W	76098	0.1
7b	Bushing Kit - Gold (2 ea.)	QMTBK-G	76540	0.1
8	Pivot Shaft Bracket Kit* (1 ea.)	QMTPSBK	76099	2.0
9	Torsion Arm Kit* (1 ea.)	PSTA	75896	5.2
10	Jam Nut Kit QMT Tensioner	JNK-C	79893	0.1
-	QMT Spring Tensioner* - Purple (incl. 1 ea. Items 5, 6, 7, 8, & 9) for blades 250-700mm (10-28")	QMT-P	76074	9.3
-	QMT Spring Tensioner* - White (incl. 1 ea. Items 5, 6a, 7a, 8, & 9) for blades 850-1750mm (34-70")	QMT-W	76075	9.9
-	QMT Spring Tensioner* - Gold (incl. 1 ea. Items 5, 6b, 7b, 8, & 9) for blades 1900-2050mm (76-82")	QMT-G	76483	10.5

\*Hardware Included

Lead Time: 1 working day

### Replacement ConShear™ Blades

REF	BLADE WIDTH		ORDERING NUMBER	ITEM CODE	WT. KG
	mm	in.			
11	200	8	CRB-200	78239	2.0
	300	12	CRB-300	78240	2.5
	350	14	CRB-350	78241	3.0
	450	18	CRB-450	78242	4.0
	600	24	CRB-600	78243	5.0
	750	30	CRB-750	78244	6.5
	800	32	CRB-800	78245	7.0
	950	38	CRB-950	78246	8.0
	1000	40	CRB-1000	78247	8.5
	1150	46	CRB-1150	78248	10.0
	1200	48	CRB-1200	78249	10.5
	1350	54	CRB-1350	78250	11.5
	1400	56	CRB-1400	78251	12.0
	1550	62	CRB-1550	78252	13.0
	1600	64	CRB-1600	78253	13.5
	1750	70	CRB-1750	78254	14.5
	1800	72	CRB-1800	78255	15.0
	1950	78	CRB-1950	78256	16.5

Blade width for your belt width's material path: Belt Width Minus 50mm (2"), 200mm (8"), or 350mm (14").

Lead Time: 1 working day

### Spring Tensioner Selection Chart

CLEANER BLADE WIDTH	76074 QMT-P	76075 QMT-W	76843 QMT-G
ConShear™ 200-700mm (10-28")	X		
ConShear™ 850-1750mm (34-70")		X	
ConShear™ 1900-2050mm (76-82")			X

## Section 10 - Other Flexco Conveyor Products

---

Flexco provides many conveyor products that help your conveyors to run more efficiently and safely. These components solve typical conveyor problems and improve productivity. Here is a quick overview on just a few of them:

### MHS Secondary Cleaner with Service Advantage Cartridge

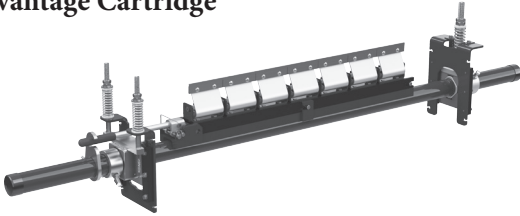

- An easy slide-out cartridge for service
- Cartridge design to speed up blade-change maintenance
- Patented PowerFlex™ Cushions for superior cleaning performance with Flexco mechanical splices

### MDWS DryWipe Secondary Cleaner

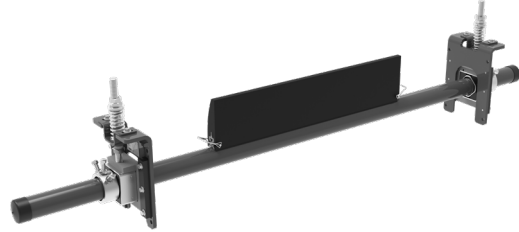

- Wipes the belt dry as final cleaner in system
- Automatic blade tensioning to the belt
- Easy, visual blade tension check
- Simple, one-pin blade replacement

### Flexco Specialty Belt Cleaners



- “Limited space” cleaners for tight conveyor applications
- High Temp cleaners for severe, high heat applications
- A rubber fingered cleaner for chevron and raised rib belts
- Multiple cleaner styles in stainless steel for corrosive applications

### PT Max™ Belt Trainer



- Patented “pivot & tilt” design for superior training action
- Dual sensor rollers on each side to minimize belt damage
- Pivot point guaranteed not to freeze up
- Available for topside and return side belts

### DRX Impact Beds



- Exclusive Velocity Reduction Technology™ to better protect the belt
- Slide-Out Service™ gives direct access to all impact bars for change-out
- Impact bar supports for longer bar life
- 4 models to custom fit to the application

### Belt Plows



- A belt cleaner for the tail pulley
- Exclusive blade design quickly spirals debris off the belt
- Economical and easy to service
- Available in vee or diagonal models



Visit [www.flexco.com](http://www.flexco.com) for other Flexco locations and products, or to find an authorised distributor.

©2020 Flexible Steel Lacing Company. 07-22-24. X2440

