

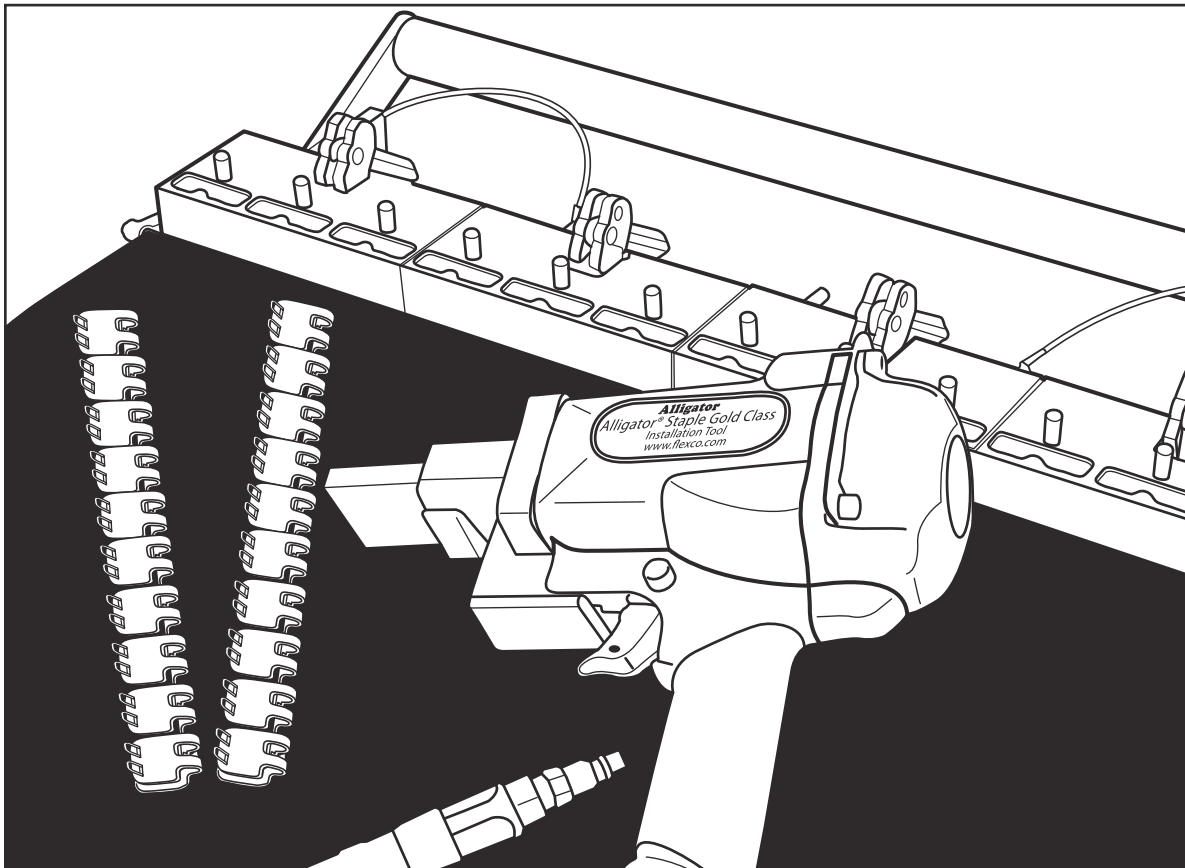

Safety and Operating Manual

Alligator[®] Staple Gold Class[™] Plus



WARNING

This manual contains important information about product function and safety. Please read and understand this manual BEFORE operating the tool. Please keep this manual available for other users and owners before they use the tool. This manual should be stored in a safe place. Also available online at flexco.com.



Patents: www.flexco.com/patents

Table of Contents

Introduction..... 2

Main Components..... 2

General Safety Rules..... 3

Maintenance and Instructions for Installation..... 5

Spare Parts 7

Introduction

The 24” (610mm) (55590) and 48” (1219mm) (112899) Alligator® Staple Gold Class™ Plus tool is designed to be used in conjunction with the Alligator® Gold Class Power Driver. Together these tools will install the complete line of Flexco Alligator® Ready Set™ Staple fasteners.

Main Components

1. Handle
2. Guide Block (4)
3. Cam Lever (4)
4. Release Handle (2)
5. Fastener Size Pin (2)

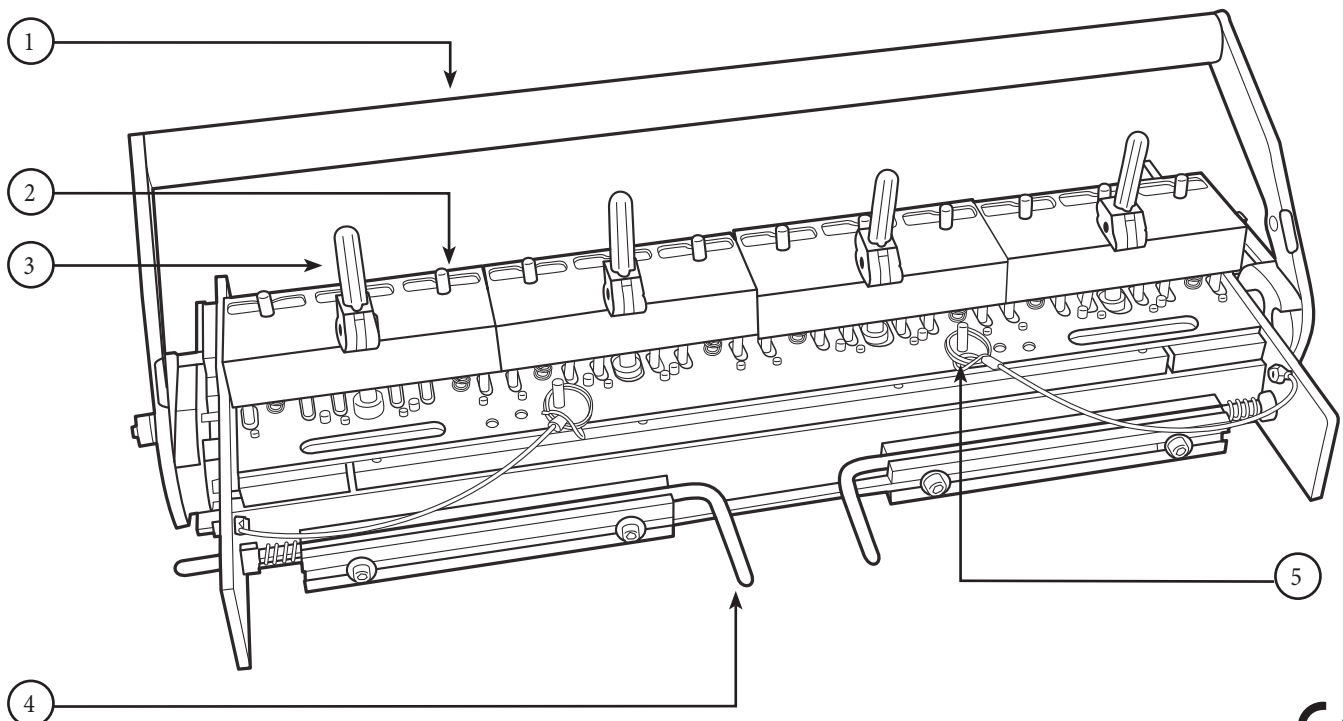

General Safety Rules

—Save These Instructions—

Signal words:

“DANGER” indicates an imminently hazardous situation which, if not avoided, will result in death or serious injury. The signal word is limited to the most extreme situations.

“WARNING” indicates a potentially hazardous situation which, if not avoided, could result in death or serious injury.

“CAUTION” indicates a potentially hazardous situation which, if not avoided, may result in minor or moderate injury. It may also be used to alert against unsafe practices.

Safety Symbol



This international safety symbol is used to identify and call attention to specific safety matters.

Safety Information

To Avoid Severe Personal Injury or Property Damage, read carefully and understand the following Safety Precautions.

1. WORK AREA

⚠ CAUTION

Keep your work area clean and well lit. Cluttered benches and dark areas invite accidents.

2. PERSONAL SAFETY

⚠ WARNING

Stay alert, watch what you are doing and use common sense when operating a power tool. Do not use tool while tired or under the influence of drugs, alcohol, or medication. A moment of inattention while operating power tools may result in serious personal injury.

⚠ WARNING

Dress properly. Do not wear loose clothing or jewelry. Contain long hair. Keep your hair, clothing, and gloves away from moving parts. Loose clothes, jewelry, or long hair can be caught in moving parts.

⚠ WARNING

Do not overreach. Keep proper footing and balance at all times. Proper footing and balance enables better control of the tool.

⚠ CAUTION

Use safety equipment. Always wear eye protection, dust mask, non-skid safety shoes, and hard hat. Hearing protection is required when driving fasteners.

⚠ WARNING

Never alter or remove safety devices.

⚠ WARNING

Keep hands and fingers away from all moving parts at all times.

General Safety Rules

3. TOOL USE AND CARE

! WARNING

Always use tool on a level, firm surface.

! CAUTION

Do not force tool.

! WARNING

Store idle tools out of reach of children and other untrained persons.

! CAUTION

Maintain tools with care. Properly maintained tools are less likely to bind and are easier to control.

! CAUTION

Check for misalignment or binding of moving parts, breakage of parts, and any other condition that may affect the tool's operation. If damaged, have the tool serviced before using. Many accidents are caused by poorly maintained tools.

! CAUTION

The 24" (610mm) Gold Class Plus (55590) weighs 51 lbs (23.1 kg).

The 48" (1219mm) Gold Class Plus (112899) weighs 100 lbs (45.4 kg).

! WARNING

Do not only operate this tool with flammable gases or oxygen.

4. SERVICE AND MAINTENANCE

! CAUTION

When servicing a tool, use only Flexco or equivalent replacement parts. Use of unauthorized parts or failure to follow maintenance instructions may create a risk of injury.

! CAUTION

Do not wipe plastic parts with solvent. Solvents such as gasoline, thinner, benzene, carbon tetrachloride, and alcohol may damage and crack plastic parts. Clean tool with brush only.

! WARNING

NEVER use a tool which is defective or operating abnormally. Stop using it immediately and arrange for repairs when operating unusually, making strange noises, vibrating excessively, or emitting odor.

! WARNING

Do not remove regulator whip assembly from Alligator® Staple Gold Class™ Driver.

! WARNING

Do not exceed 120 PSI incoming air pressure.

! WARNING

Do not depress tool trigger before tool is seated completely down on top of guide block. Oil air line on Alligator® Staple Gold Class™ Driver with one to two drops prior to use.

Alligator® Staple Gold Class™ Plus

Operation

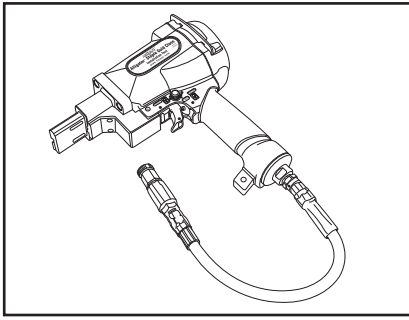

1. Do not remove regulatory whip assembly. Connect the Alligator® Staple Gold Class™ Driver (Model Number 55541) to a clean, dry air line with a maximum incoming pressure of 120 PSI. The driver regulator will bring air source down to 70 PSI. Oil air line with one to two drops prior to use.

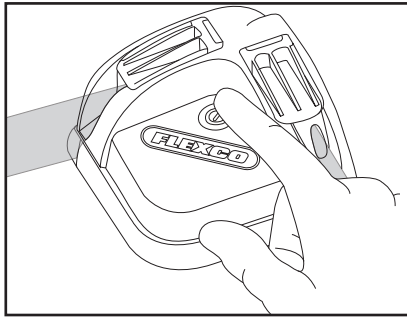

2. (a) Square belt ends. (b) Cut belt using a Flexco belt cutting tool.

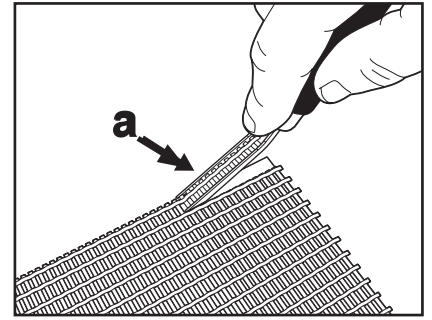

3. (a) Skive rough-top belt using Flexco skiving products. Select correct fastener size by using the chart on page 7.

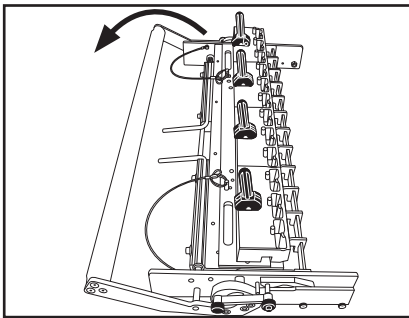

4. Make sure the tool is in initial position. This position is when the handle is all the way back and locked.

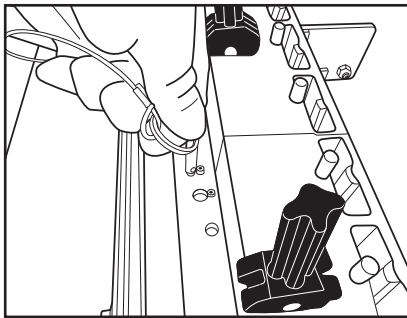

5. To change fastener size setting, pull both pins from the tool base.

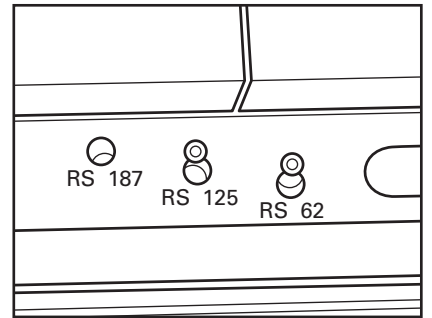

6. Move template so corresponding fastener size matches the base hole. Then reinsert both pins.

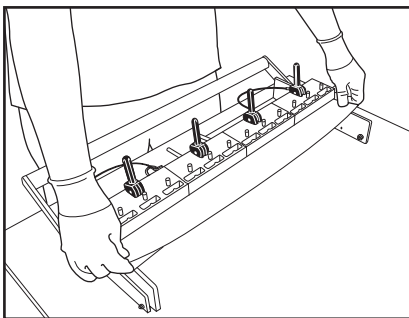

7. Center fastener strip in the tool. Fastener Strip should be tight against tool. (a) Cam lever(s) should be up. Center belt in installation tool, equal distance between belt ends.

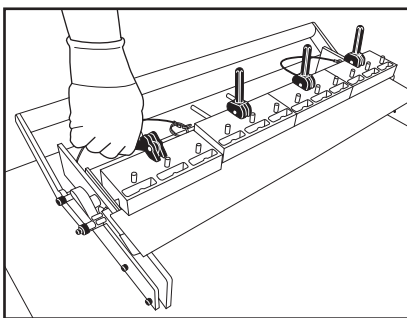

8. (a) Belt end should be tight against the fastener belt stops. (b) Depress cam lever(s). Fastener top should lean forward. If not, tighten handle clockwise to increase pressure and repeat. To prevent damage to the tool, do not overtighten cam levers.

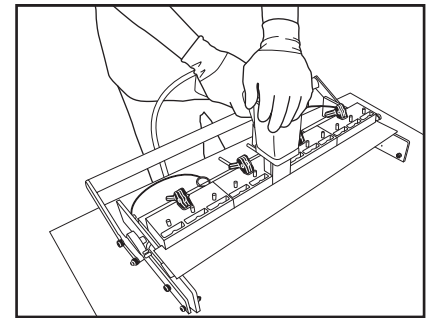

9. Starting with the center fastener plates, insert the nose of the Alligator Staple Gold Class Driver into the guide block. **Note:** the driver must be firmly seated into the pin to activate safety switch. DO NOT depress tool trigger before tool is seated completely down on top of guide block, as this will damage the tool. Apply adequate number of trigger pulls to produce sufficient staple leg fold. Refer to chart on page 7. Drive remaining staples as follows.



Alligator® Staple Gold Class™ Plus

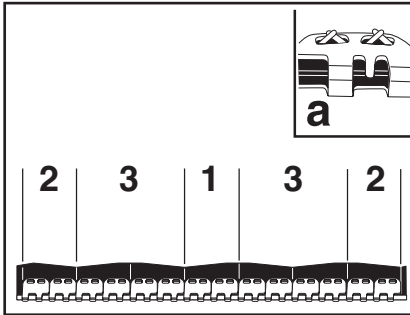

10. Follow the sequence shown above to drive all remaining fasteners. Staples will be partially clinched.

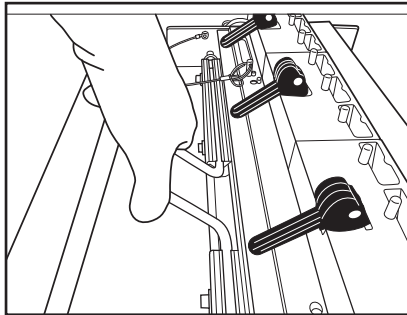

11. Squeeze both release handles to allow the tool to change position.

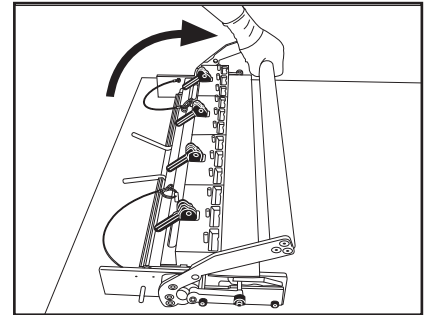

12. Move the handle from initial position into final position to move anvil into finishing position. Repeat steps 9 & 10. Refer to chart below for average trigger pulls.

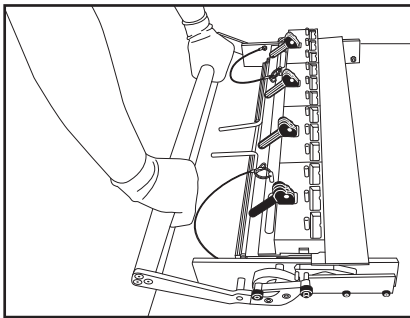

13. Return the handle into the initial position and lock it down. Release Cam Levers and remove belt from the tool.

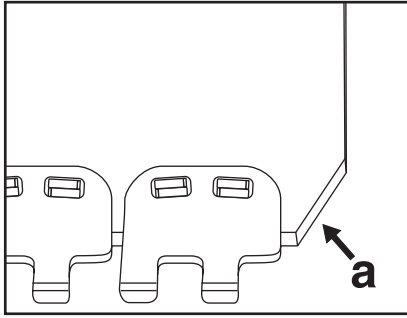

14. Using Belt Nippers, notch corners of trailing edge. Notch at an angle as shown.

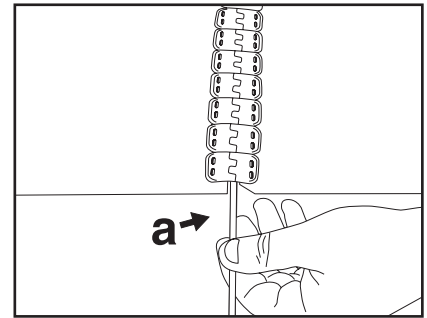

15. Bring belt ends together and insert hinge pin. If retaining washer is used, crimp with pliers. Splice is complete.

AVERAGE TRIGGER PULLS

Fastener Size	Average Trigger Pulls for:	
	Initial Drive	Final Set
RS62	1-2	1-2
RS125	2-3	2-3
RS187	3-4	3-4

Note: Number of trigger pulls will vary depending on belt thickness and durometer. Do not overdrive staples.

Alligator® Ready Set™ Staple Fasteners Selection Chart

Fastener Size	Operating Tension Range		Belt Thickness Range		Min. Pulley Diameter		Approx. Hinge Pin Diameter	
	P.I.W.	kN/m	in.	mm	in.	mm	in. (nylon-steel)	mm (nylon-steel)
RS62	100	17	1/16-1/8	1.5-3.2	2	50	nylon .080, steel .080	nylon 2.0, steel 2.0
RS125	160	28	1/8-3/16	3.2-4.8	3	75	nylon .141, steel .141	nylon 3.6, steel 3.6
RS187	200	35	3/16-1/4	4.8-6.4	4	102	nylon .203, steel .187	nylon 5.2, steel 4.7

Maintenance Tips

- Clean tool with brush only.
- DO NOT use air pressure.
- Add lubricant as required.

Spare Parts

1. Cam Lever
2. Guide Block
3. Anvil Replacement Kit

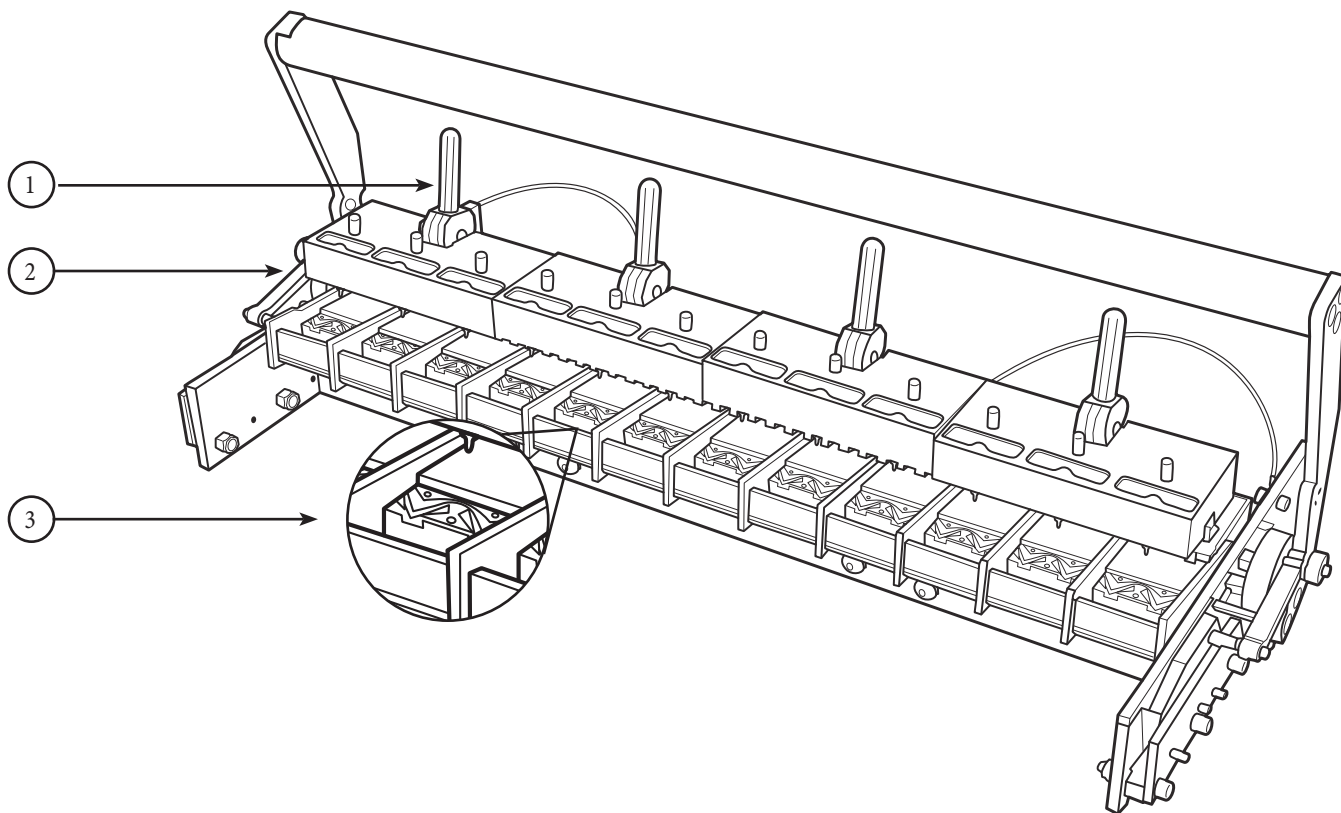

Spare Parts List		
Description	Ordering Number	Item Code
Cam Lever	ST8-Cam	55592
Guide Block	ST7-5	55554
Anvil Replacement Kit	ST8-A-SN200	55589



Partners in Productivity

EU DECLARATION OF CONFORMITY

Product: Ready Set Pneumatic Tool

Manufacturer: Flexible Steel Lacing Co. (Flexco)
2525 Wisconsin Dr.
Downers Grove, IL 60515

European office: Flexco Europe
Leidringer Strasse 40-42
D-72348, Rosenfeld Germany
Telephone 49-7428-9406-0

This declaration of conformity is issued under the sole responsibility of the manufacturer.

Object of this declaration:



Ready Set Pneumatic Tool: Model 55541
Installation Tool: 55590 & 112899

The object of the declaration described above is in conformity with the relevant Union harmonization legislation.

Harmonized Standards and Technical Specifications applied:

ISO 12100:2010	Safety of machinery—General principle for design—Risk assessment and risk reduction
EN ISO 4414:2010	Pneumatic Fluid Power – General Rules and Safety Requirements for Systems and their Components
EN ISO 11148-13	Safety of Machinery – Hand-held Non-Electric Power Tools Part 13: Fastener Driving Tools

Signed for and on behalf of:

Flexible Steel Lacing Company (Flexco)

Thomas S. Wujek, Executive VP & COO

20 December 2024

Date

2525 Wisconsin Drive • Downers Grove, Illinois 60515 • Tel 1-630-971-0150 • Fax: 1-630-971-1180 • www.flexco.com

